



**Economic and Social
Council**

Distr.
GENERAL

ECE/TRANS/WP.29/GRE/2004/5/Rev.2 */
19 January 2006

Original: ENGLISH
ENGLISH AND FRENCH ONLY

ECONOMIC COMMISSION FOR EUROPE

INLAND TRANSPORT COMMITTEE

World Forum for Harmonization of Vehicle Regulations (WP.29)

Working Party on Lighting and Light-Signalling (GRE)

(Fifty-sixth session, 4-7 April 2006,
agenda item 8.)

REVISED PROPOSAL FOR DRAFT AMENDMENTS TO REGULATIONS Nos. 48 and 87

Transmitted by the expert from the Working Party "Brussels 1952" (GTB)

Note: The text reproduced below was prepared by the expert from GTB, in order to update the photometric requirements in Regulation No. 87, taking into account research results, and to promote the installation of dedicated daytime running lamps (DRL) by vehicle manufacturers. In addition, the proposal introduces in Regulation No. 48 conditions for DRL automatically switching ON/OFF. The modifications to the original text of TRANS/WP.29/GRE/2004/5/Rev.1 and to the current text of Regulation No. 48 are marked in **bold** characters.

Note: This document is distributed to the Experts on Lighting and Light-Signalling only.

*/ The previous version of the present document was circulated under symbol number TRANS/WP.29/GRE/2004/5/Rev.1

A.1. PROPOSAL

REGULATION No. 48 – (Installation of lighting and light-signalling devices)

Paragraph 6.2.7., amend to read:

"6.2.7.

Dipped-beam headlamps may be switched ON or OFF automatically.

Dipped-beam headlamps shall be switched ON and OFF automatically depending on ambient lighting conditions, if daytime running lamps are installed [and the dipped beam headlamps are not operating in conjunction with rear position lamps].

However, it shall be possible always to switch these dipped-beam headlamps ON and OFF manually."

Insert a new paragraph 7.4., to read:

"7.4. As from 24 months after the official date of entry into force of Supplement [15] to the [02] series of amendments, Contracting Parties applying this Regulation shall grant ECE approvals only if the vehicle type to be approved meets the requirements of this Regulation as amended by Supplement [15] to the [02] series of amendments." */

*/ Note by secretariat: if 03 series of amendments to Regulation No. 48 are approved during the one-hundred-and-thirty-ninth WP.29 session (ECE/TRANS/WP.29/2006/15), this proposal would become Supplement 1 to the 03 series of amendments.

A.2. PROPOSAL

REGULATION No. 87 – (Daytime running lamps)

List of contents (ANNEXES), amend to read:

"

Annex 6 - Minimum requirements for sampling by an inspector

Annex 7 - Minimum angles required for light distribution in space"

Text of the Regulation.

Paragraphs 7.1. to 7.3., amend to read:

- "7.1. The **luminous** intensity of the light emitted by each lamp shall not be less than **500 cd** in the axis of reference.
- 7.2. Outside the reference axis **and within the angular fields defined in the arrangement diagram in Annex 7 to this Regulation, the intensity of the light emitted by each lamp must:**
- 7.2.1. In each direction corresponding to the points in the **table of standard light distribution** reproduced in Annex 3 to this Regulation, **be not less than the minimum specified in paragraph 7.1. above, multiplied** by the percentage specified in the said table of the direction in question, **and**
- 7.2.2. **not exceed 1,500 cd in any direction the lamp is visible.**
- 7.3. **Moreover, throughout the field defined in the diagram in Annex 7, the intensity of the light emitted must not be less than 1.0 cd."**

Paragraph 8., amend to read:

"8. **APPARENT SURFACE**

The area of the **apparent surface in the direction of the axis of reference of the lamp** shall not be less than **25 cm²** and not more than **200 cm²**."

Annex 3, paragraph 5., amend the table of standard light distribution to read:

"

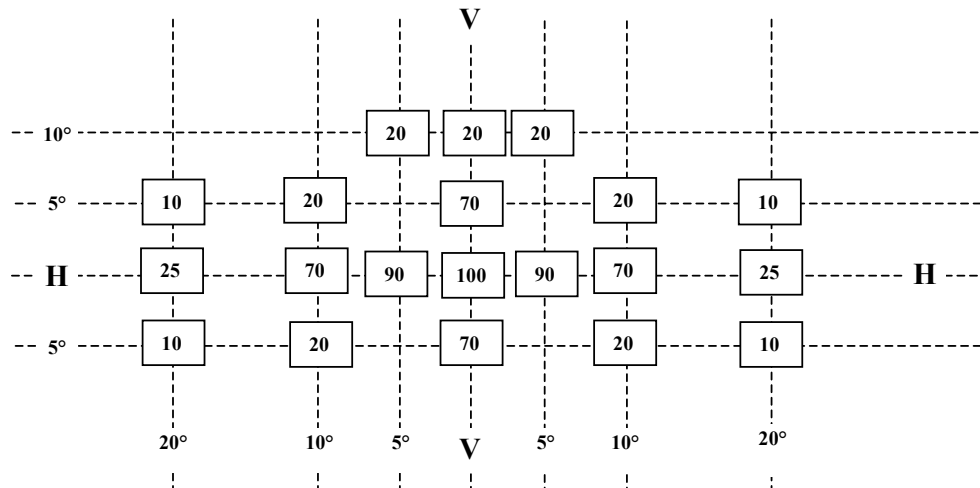

"

Insert a new Annex 7, to read:

"Annex 7

MINIMUM ANGLES REQUIRED FOR LIGHT DISTRIBUTION IN SPACE

In all cases, the minimum vertical angles of light distribution in space are 10° above and 5° below the horizontal for DRL devices included in the Regulation.

Minimum horizontal angles of light distribution in space:

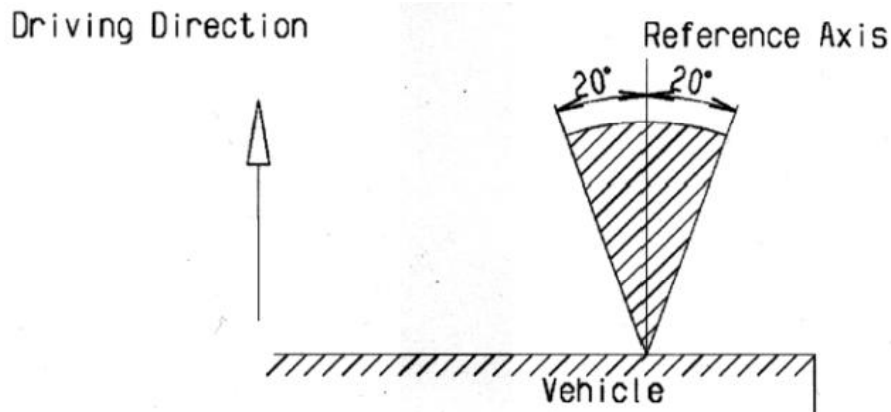

B. JUSTIFICATION

More and more countries are making the use of lighting devices during daytime a use requirement. The existing ECE Regulation No. 87 requirement for 40 cm² is from a time when vehicle front ends were much more upright and square. Modern pedestrian friendly front-end designs mean there is much less space in which to package the old size devices.

To comply with those national use requirements, vehicle manufacturers are tending to use dipped beam headlamps, to fulfil this function, which in turn uses more fuel and can mean that the filament life is exhausted sooner than if it were used only as a night time function.

To enable a dedicated DRL function to be provided, with current design restrictions a reduced area is required, which will also reduce this use dependence on the dipped beam filament.

In a recent study through UMTRI (2003-11 Functional requirements from DRL), Professor Kare Rumar of Sweden came to the conclusion that a smaller brighter DRL lamp would provide adequate illumination levels.

The standard light distribution in Annex 3 of Regulation No. 87 has been modified to restrict the requirements to 5 degrees down. This is because a DRL is intended to give advanced warning of the presence or approach of a vehicle and there is unlikely to be a case where the viewing angle will be below 5 degrees down.

The current photometric table requires the beam to extend to 10 degrees down, but to achieve this it is necessary to divert useful flux from the effective areas.

Annex 7 has been introduced to define the angles of light distribution in space, in line with other signal lamps regulations.

In line with other proposed harmonization activities an area requirement of 12.5 cm² from H20° left to H20° right is proposed as an optional requirement.
