



**Economic and Social
Council**

Distr.
GENERAL

TRANS/WP.29/2003/85
30 July 2003

Original: ENGLISH

ECONOMIC COMMISSION FOR EUROPE

INLAND TRANSPORT COMMITTEE

World Forum for Harmonization of Vehicle Regulations (WP.29)
(One-hundred-and-thirty-first session,
11-14 November 2003, agenda item 4.2.33.)

PROPOSAL FOR DRAFT SUPPLEMENT 1 TO THE 02 SERIES OF AMENDMENTS TO
REGULATION No. 95

(Lateral collision)

Transmitted by the Working Party on Passive Safety (GRSP)

Note: The text reproduced below was adopted by GRSP at its thirty-third session, and is transmitted for consideration to WP.29 and to AC.1. It is based on documents TRANS/WP.29/GRSP/2002/11, as amended (TRANS/WP.29/GRSP/33, paras. 32 - 34 and annex 4).

This document is a working document circulated for discussion and comments. The use of this document for other purposes is the entire responsibility of the user.

Documents are also available via the INTERNET:
<http://www.unece.org/trans/main/welcwp29.htm>

Paragraph 10.1., amend to read:

"10.1. As from the official date of entry into force of Supplement 1 to the 02 series of amendments as amended by Supplement 1 to the 02 series of amendments."

Insert new paragraphs 10.4. and 10.5., to read:

"10.4. As from [36] months after the entry into force of Supplement 1 to the 02 series of amendments Contracting Parties applying this Regulation shall grant ECE approvals only to those types of vehicles which comply with the requirements of this Regulation. as amended by Supplement 1 to the 02 series of amendments.

10.5. As from [84] months after the entry into force of Supplement 1 to the 02 series of amendments Contracting Parties applying this Regulation may refuse first national registration (first entry into service) of vehicles which do not meet the requirements of this regulation as amended by Supplement 1 to the 02 series of amendments."

Annex 1.

Insert a new item 6., to read:

"6. Side impact dummy utilized ES-1/ES-2. 2/"

Items 6 to 14 (former), renumber as items 7 to 15.

Annex 6., amend to read:

"Annex 6

TECHNICAL DESCRIPTION OF THE SIDE IMPACT DUMMY

1. GENERAL

1.1. The side impact dummy prescribed in this Regulation, including the instrumentation and calibration, is described in technical drawings and a user's manual 1/.

1.2. The dimensions and masses of the side impact dummy represent a 50th percentile adult male, without lower arms.

1.3. The side impact dummy consists of a metal and plastic skeleton covered by flesh-simulating rubber, plastic and foam.

2. CONSTRUCTION

1/ The dummy is corresponding with the specification of the ES-2 dummy. The number of the table of contents of the technical drawing is : No. E-AA-DRAWING-LIST-7-25-032 dated 25 July 2003. The complete set of ES-2 technical drawings and the ES-2 User Manual are deposited with the United Nations Economic Commission for Europe (UNECE), Palais des Nations, Geneva, Switzerland and may be consulted on request at the secretariat.

- 2.1. For an overview of the side impact dummy see Figure 1 for a scheme and the parts breakdown in Table 1 of this annex.
- 2.2. Head
 - 2.2.1. The head is shown as part No. 1 in Figure 1 of this annex.
 - 2.2.2. The head consists of an aluminium shell covered by a pliable vinyl skin. The interior of the shell is a cavity accommodating tri-axial accelerometers and ballast.
 - 2.2.3. At the head-neck interface a load cell replacement is built in. This part can be replaced with an upper neck load-cell.
- 2.3. Neck
 - 2.3.1. The neck is shown as part No. 2 in Figure 1 of this annex.
 - 2.3.2. The neck consists of a head-neck interface piece, a neck-thorax interface piece and a central section that links the two interfaces to one another.
 - 2.3.3. The head-neck interface piece (part No. 2a) and the neck-thorax interface piece (part No. 2c) both consist of two aluminium disks linked together by means of a half spherical screw and eight rubber buffers.
 - 2.3.4. The cylindrical central section (part No. 2b) is made of rubber. At both sides an aluminium disk of the interface pieces is moulded in the rubber part.
 - 2.3.5. The neck is mounted on the neck-bracket, shown as part No. 2d in Figure 1 of this annex. This bracket can optionally be replaced with a lower neck load-cell.
 - 2.3.6. The angle between the two faces of the neck-bracket is 25 degrees. Because the shoulder block is inclined 5 degrees backwards, the resulting angle between the neck and torso is 20 degrees.
- 2.4. Shoulder
 - 2.4.1. The shoulder is shown as part No. 3 in Figure 1 of this annex.
 - 2.4.2. The shoulder consists of a shoulder box, two clavicles and a shoulder foam cap.
 - 2.4.3. The shoulder box (part No. 3a) consists of an aluminium spacer block, an aluminium plate on top and an aluminium plate on the bottom of the spacer block. Both plates are covered with a polytetrafluorethen (PTFE)-coating.
 - 2.4.4. The clavicles (part No. 3b), made of cast polyurethane (PU)-resin, are designed to evolve over the spacer block. The clavicles are held back in their neutral position by two elastic cords (part No. 3c) which are clamped to the rear of the shoulder box. The outer edge of both clavicles accommodates a design allowing for standard arm positions.
 - 2.4.5. The shoulder cap (part No. 3d) is made of low-density polyurethane foam and is attached to the shoulder block.

2.5. Thorax

2.5.1. The thorax is shown as part No. 4 in Figure 1 of this annex.

2.5.2. The thorax consists of a rigid thoracic spine box and three identical rib modules.

2.5.3. The thoracic spine box (part No. 4a) is made of steel. On the rear surface a steel spacer and curved, polyurethane (PU)-resin, back plate is mounted (part No. 4b).

2.5.4. The top surface of the thoracic spine box is inclined 5 degrees backwards.

2.5.5. At the lower side of the spine box a T12 load cell or load cell replacement (part No. 4j) is mounted.

2.5.6. A rib module (part No. 4c) consists of a steel rib bow covered by a flesh-simulating open-cell polyurethane (PU) foam (part No. 4d), a linear guide system assembly (part No. 4e) linking the rib and spine box together, a hydraulic damper (part No. 4f) and a stiff damper spring (part No. 4g).

2.5.7. The linear guide system (part No. 4e) allows the sensitive rib side of the rib bow (part No. 4d) to deflect with respect to the spine box (part No. 4a) and the non-sensitive side. The guide system assembly is equipped with linear needle bearings.

2.5.8. A tuning spring is located in the guide system assembly (part No. 4h).

2.5.9. A rib displacement transducer (part No. 4i) can be installed on the spine box mounted part of guide system (part No. 4e) and connected to the outer end of the guide system at the sensitive side of the rib.

2.6. Arms

2.6.1. The arms are shown as part No. 5 in Figure 1 of this annex.

2.6.2. The arms have a plastic skeleton covered by a polyurethane (PU) flesh representation with a polyvinylchloride (PVC) skin. The flesh representation consists of a high-density polyurethane (PU) moulding upper part and a polyurethane (PU) foam lower part.

2.6.3. The shoulder-arm joint allows for discrete arm positions at 0, 40 and 90 degree setting with respect to the torso axis.

2.6.4. The shoulder-arm joint allows for a flexion-extension rotation only.

2.7. Lumbar spine

2.7.1. The lumbar spine is shown as part No. 6 in Figure 1 of this annex.

2.7.2. The lumbar spine consists of a solid rubber cylinder with two steel interface plates at each end, and a steel cable inside the cylinder.

2.8. Abdomen

2.8.1. The abdomen is shown as part No. 7 in Figure 1 of this annex.

2.8.2. The abdomen consists of a rigid central part and a foam covering.

2.8.3. The central part of the abdomen is a metal casting (part No. 7a). A cover plate is mounted on top of the casting.

2.8.4. The covering (part No. 7b) is made of polyurethane (PU) foam. A curved slab of rubber filled with lead-pellets is integrated in the foam covering at both sides.

2.8.5. Between the foam covering and the rigid casting at each side of the abdomen, either three force transducers (part No. 7c) or three non-measuring replacement units can be mounted.

2.9. Pelvis

2.9.1. The pelvis is shown as part No. 8 in Figure 1 of this annex.

2.9.2. The pelvis consists of a sacrum block, two iliac wings, two hip joints assemblies and a flesh simulating foam covering.

2.9.3. The sacrum (part No. 8a) consists of a mass tuned metal block and a metal plate mounted on top of this block. In the aft side of the block is a cavity to facilitate the application of instrumentation.

2.9.4. The iliac wings (part No. 8b) are made of polyurethane (PU)-resin.

2.9.5. The hip joints assemblies (part No. 8c) are made of steel parts. They consist of an upper femur bracket and a ball joint connected to an axle passing through the dummy's H-point.

The upper femur bracket abduction and adduction capability is buffered by rubber stops at the ends of the range of motion.

2.9.6. The flesh system (part No. 8d) is made of a polyvinylchloride (PVC) skin filled with polyurethane (PU) foam. At the H-point location the skin is replaced by open-cell polyurethane (PU) foam block (part No. 8e) backed up with a steel plate fixed on the iliac wing by an axle support going through the ball joint.

2.9.7. The iliac wings are attached to the sacrum block at the aft side and linked together at the pubic symphysis location by a force transducer (part No. 8f) or a replacement transducer.

2.10. Legs

2.10.1. The legs are shown as part No. 9 in Figure 1 of this annex.

2.10.2. The legs consist of a metal skeleton covered by flesh-stimulating polyurethane (PU) foam with a polyvinylchloride (PVC) skin.

2.10.3. A high-density polyurethane (PU) moulding with a polyvinylchloride (PVC) skin represents the thigh flesh of the upper legs.

2.10.4. The knee and ankle joint allow for a flexion/extension rotation only.

2.11. Suit

2.11.1. The suit is not shown in Figure 1 of this annex.

2.11.2. The suit is made of rubber and covers the shoulders, thorax, upper part of the arms, the abdomen and lumbar spine, the upper part of the pelvis.

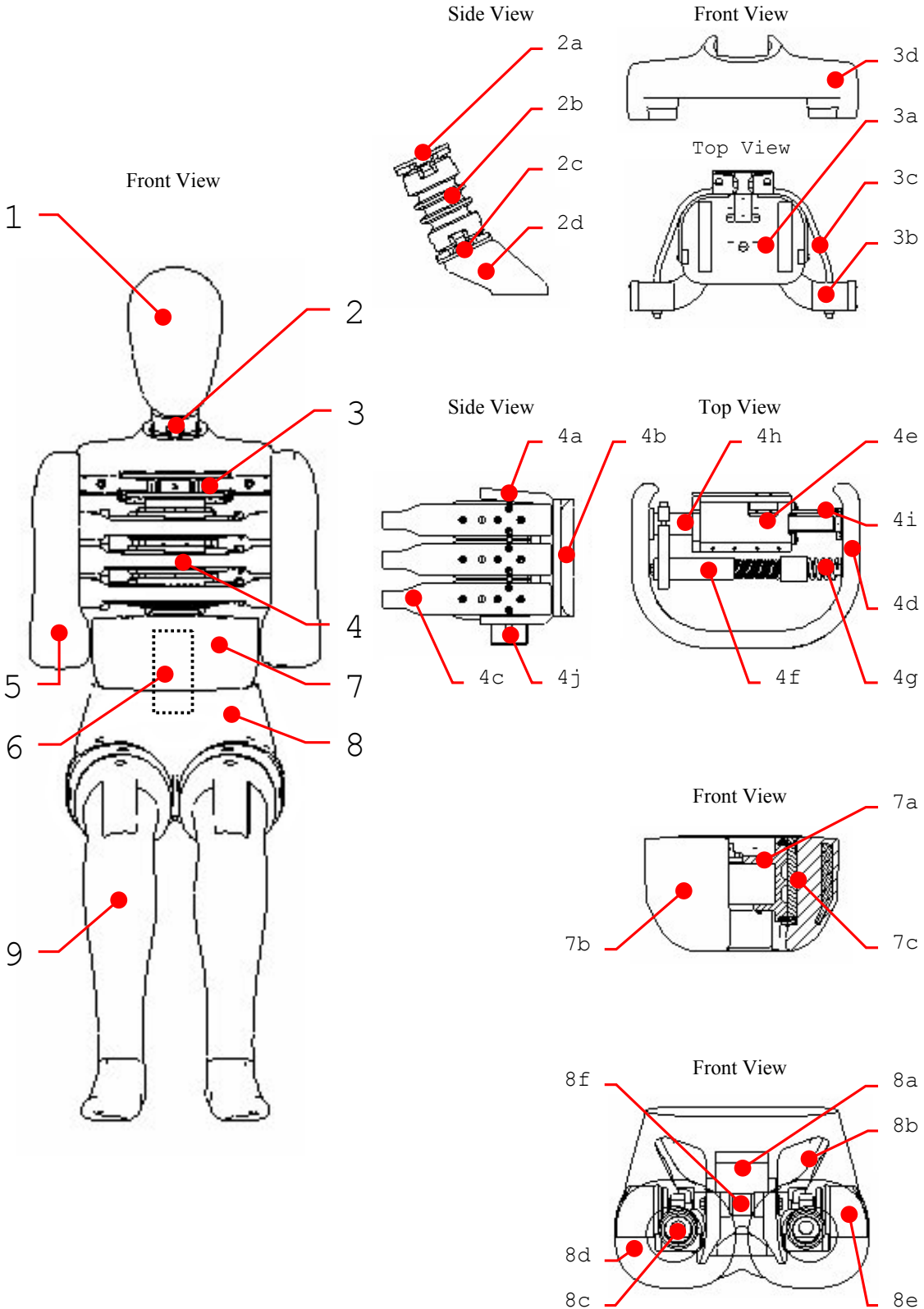

Figure 1 - Construction of side impact dummy

Table 1 - Side Impact Dummy Components (See Figure 1)

Part	No.	Description	Number per dummy
1		Head	1
2		Neck	1
	2a	Head-neck interface	1
	2b	Central section	1
	2c	Neck-thorax interface	1
	2d	Neck-bracket	1
3		Shoulder	1
	3a	Shoulder box	1
	3b	Clavicle	2
	3c	Elastic cord	2
	3d	Shoulder foam cap	1
4		Thorax	1
	4a	Thoracic spine	1
	4b	Back plate (curved)	1
	4c	Rib module	3
	4d	Rib bow covered with flesh	3
	4e	Piston-cylinder assembly	3
	4f	Damper	3
	4g	Stiff damper spring	3
	4h	Tuning spring	3
	4i	Displacement transducer	3
	4j	T12 load cell or load cell replacement	1
5		Arm	2
6		Lumbar spine	1
7		Abdomen	1
	7a	Central casting	1
	7b	Foam covering	1
	7c	Force transducer or replacement	3
8		Pelvis	1
	8a	Sacrum block	1
	8b	Iliac wings	2
	8c	Hip joint assembly	2
	8d	Flesh covering	1
	8e	H-point foam block	1
	8f	Force transducer or replacement	1
9		Leg	2
10		Suit	1

3. ASSEMBLY OF THE DUMMY

3.1. Head-neck

3.1.1. The required torque on the half-spherical screws for assembly of the neck is 10 Nm.

3.1.2. The head-upper neck load cell assembly is mounted to the head-neck interface plate of the neck by four screws.

3.1.3. The neck-thorax interface plate of the neck is mounted to the neck-bracket by four screws.

3.2. Neck-shoulder-thorax

3.2.1. The neck-bracket is mounted to the shoulder block by four screws.

3.2.2. The shoulder-block is mounted to the top-surface of the thoracic spine box by three screws.

3.3. Shoulder-arm

3.3.1. The arms are mounted to the shoulder clavicles by means of a screw and an axial bearing. The screw shall be tightened to obtain a 1 - 2 g holding force of the arm on its pivot.

3.4. Thorax-lumbar spine-abdomen

3.4.1. The mounting direction of rib modules in the thorax shall be adapted to the required impact side.

3.4.2. A lumbar spine adapter is mounted to the T12 load cell or load cell replacement at the lower part of the thoracic spine by two screws.

3.4.3. The lumbar spine adapter is mounted to the top plate of the lumbar spine with four screws.

3.4.4. The mounting flange of the central abdominal casting is clamped between the lumbar spine adapter and the lumbar spine top plate.

3.4.5. The location of the abdominal force transducers shall be adapted to the required impact side.

3.5. Lumbar spine-pelvis-legs

3.5.1. The lumbar spine is mounted to the sacrum block cover plate by three screws. In case of using the lower lumbar spine load cell four screws are used.

3.5.2. The lumbar spine bottom plate is mounted to the sacrum block of the pelvis by three screws.

3.5.3. The legs are mounted to the upper femur bracket of the pelvis hip joint assembly by a screw.

3.5.4. The knee and ankle links in the legs can be adjusted to obtain a 1 - 2 g holding force.

4. MAIN CHARACTERISTICS

4.1. Mass

4.1.1. The masses of the main dummy components are presented in table 2 of this annex.

Table 2 - Dummy Component Masses

Component (body part)	Mass (kg)	Tolerance ±(kg)	Principle contents
Head	4.0	0.2	Complete head assembly including tri-axial accelerometer and upper neck load cell or replacement
Neck	1.0	0.05	Neck, not including neck bracket
Thorax	22.4	1.0	Neck bracket, shoulder cap, shoulders assembly, arm attachment bolts, spine box, torso back plate, rib modules, rib deflection transducers, torso back plate load cell or replacement, T12-load cell or replacement, abdomen central casting, abdominal force transducers, 2/3 of suit
Arm (each)	1.3	0.1	Upper arm, including arm positioning plate (each)
Abdomen and lumbar spine	5.0	0.25	Abdomen flesh covering and lumbar spine
Pelvis	12.0	0.6	Sacrum block, lumbar spine mounting plate, hip ball joints, upper femur brackets, iliac wings, pubic force transducer, pelvis flesh covering, 1/3 of suit
Leg (each)	12.7	0.6	Foot, lower and upper leg and flesh as far as junction with upper femur (each)
Total dummy	72.0	1.2	

4.2. Principal dimensions

- 4.2.1. The principal dimensions of the side impact dummy, based on Figure 2 of this annex, are given in table 3 of this annex.
The dimensions are measured without suit

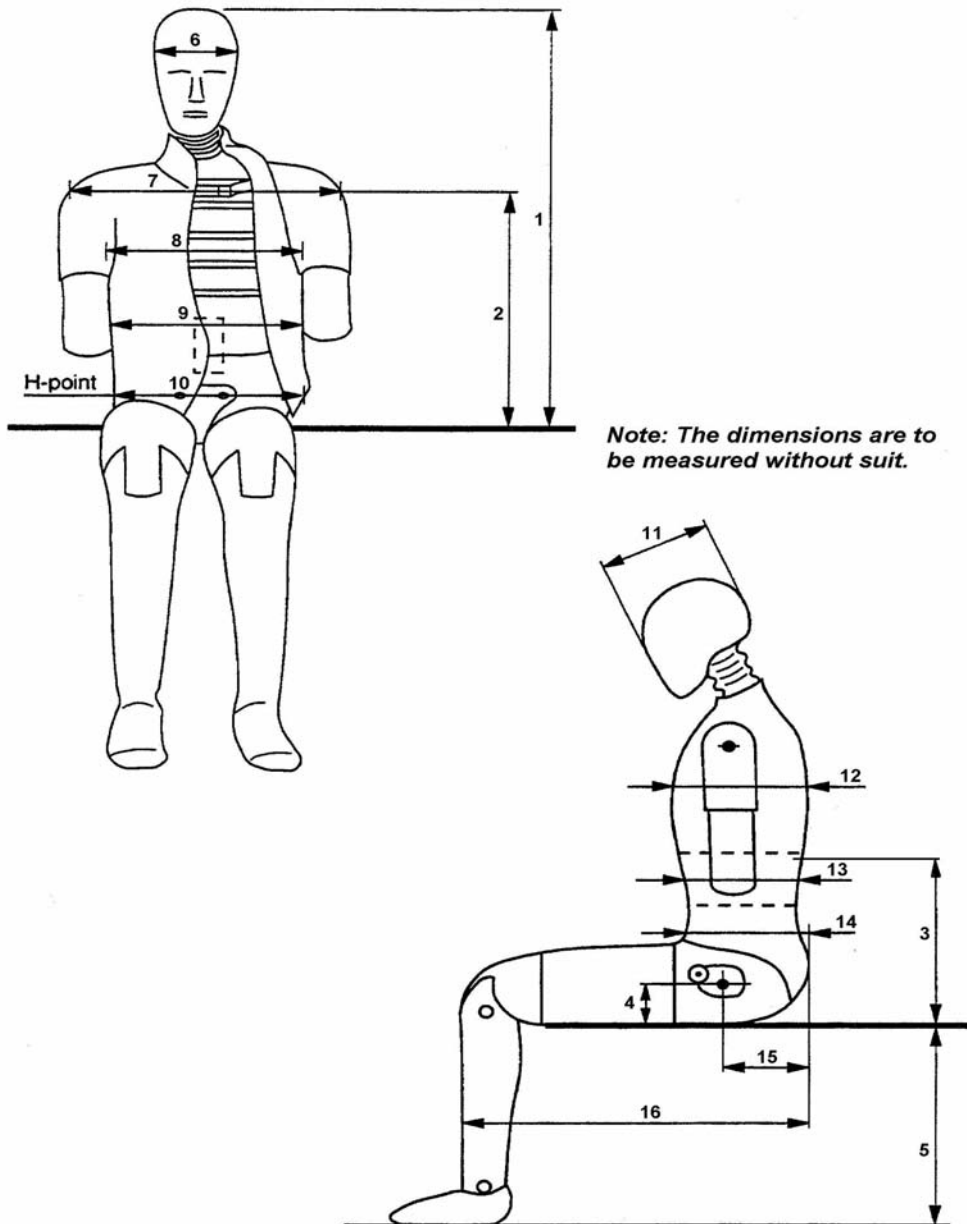

Figure 2 - Measurements for principle dummy dimensions (see Table 3)

Table 3 - Principle Dummy Dimensions

No.	Parameter	Dimension (mm)
1	Sitting height	909 ± 9
2	Seat to shoulder joint	565 ± 7
3	Seat to lower face of thoracic spine box	351 ± 5
4	Seat to hip joint (centre of bolt)	100 ± 3
5	Sole to seat, sitting	442 ± 9
6	Head width	155 ± 3
7	Shoulder / arm width	470 ± 9
8	Thorax width	327 ± 5
9	Abdomen width	280 ± 7
10	Pelvis lap width	366 ± 7
11	Head depth	201 ± 5
12	Thorax depth	267 ± 5
13	Abdomen depth	199 ± 5
14	Pelvis depth	240 ± 5
15	Back of buttocks to hip joint (centre of bolt)	155 ± 5
16	Back of buttocks to front knee	606 ± 9

5. CERTIFICATION OF THE DUMMY

5.1. Impact side

5.1.1. Depending on the vehicle side to be impacted, dummy parts should be certified on the left-hand side or right-hand side.

5.1.2. The configurations of the dummy with regards to the mounting direction of the rib modules and the location of the abdominal force transducers shall be adapted to the required impact side.

5.2. Instrumentation

5.2.1. All instrumentation shall be calibrated in compliance with the requirements of the documentation specified in paragraph 1.3.

5.2.2. All instrumentation channels shall comply with ISO 6487:2000 or SAE J211 (March 1995) data channel recording specification.

5.2.3. The minimum number of channels required to comply with this regulation is ten:

- Head accelerations (3),
- Thorax rib displacements (3),
- Abdomen loads (3) and
- Pubic symphysis load (1).

5.2.4. Additionally a number of optional instrumentation channels (38) are available:

Upper neck loads	(6),
Lower neck loads	(6),
Clavicle loads	(3),
Torso back plate loads	(4),
T1 accelerations	(3),
T12 accelerations	(3),
Rib accelerations	(6, two on each rib),
T12 spine loads	(4),
Lower lumbar loads	(3),
Pelvis accelerations	(3) and
Femur loads	(6).
Additional four position indicator channels are optionally available:	
Thorax rotations	(2) and
Pelvis rotations	(2)

5.3. Visual check

5.3.1. All dummy parts should be visually checked for damage and if necessary replaced before the certification test.

5.4. General test set-up

5.4.1. Figure 3 of this annex shows the test set-up for all certification tests on the side impact dummy.

5.4.2. The certification test set-up arrangements and testing procedures shall be in accordance with the specification and requirements of the documentation specified in paragraph 1.3.

5.4.3. The tests on the head, neck, thorax and lumbar spine are carried out on sub assemblies of the dummy.

5.4.4. The tests on the shoulder, abdomen and pelvis are performed with the complete dummy (without suit, shoes and underwear). In these tests the dummy is seated on a flat surface with two sheets of less than or equal to 2 mm thick polytetrafluorethen (PTFE), placed between the dummy and the flat surface.

5.4.5. All parts to be certified should be kept in the test room for a period of at least four hours at a temperature between and including 18 and 22 degrees Celsius and a relative humidity between and including 10 and 70 per cent prior to a test.

5.4.6. The time between two certification tests on the same part should be at least 30 minutes.

5.5. Head

- 5.5.1. The head sub assembly, including the upper neck load cell replacement, is certified in a drop test from 200 ± 1 mm onto a flat, rigid impact surface.
- 5.5.2. The angle between the impact surface and the mid-sagittal plane of the head is 35 ± 1 degree allowing an impact to the upper part of the head side (this can be realised with a sling harness or a head drop support bracket with a mass of 0.075 ± 0.005 kg.).
- 5.5.3. The peak resultant head acceleration, filtered using ISO 6487:2000 CFC 1000, should be between and including 100 g and 150 g.
- 5.5.4. The head performance can be adjusted to meet the requirement by altering the friction characteristics of the skin-skull interface (e.g. by lubrication with talcum powder or polytetrafluorethen (PTFE) spray).

5.6. Neck

- 5.6.1. The head-neck interface of the neck is mounted to a special certification head-form with a mass of 3.9 ± 0.05 kg (see Figure 6), with the help of a 12 mm thick interface plate with a mass of 0.205 ± 0.05 kg.
- 5.6.2. The head-form and neck are mounted upside-down to the bottom of a neck-pendulum 2/ allowing a lateral motion of the system.
- 5.6.3. The neck-pendulum is equipped with a uni-axial accelerometer according to the neck pendulum specification (see Figure 5).
- 5.6.4. The neck-pendulum should be allowed to fall freely from a height chosen to achieve an impact velocity of 3.4 ± 0.1 m/s measured at the pendulum accelerometer location.
- 5.6.5. The neck-pendulum is decelerated from impact velocity to zero by an appropriate device 3/, as described in the neck pendulum specification (see Figure 5), resulting in a velocity change - time history inside the corridor specified in Figure 7 and Table 4 of this annex. All channels have to be recorded according to the ISO 6487:2000 or SAE J211 (March 1995) data channel recording specification and filtered digitally using ISO 6487:2000 CFC 180.

2/ Neck pendulum corresponding with American Code of Federal Regulation 49 CFR Chapter V Part 572.33 (10-1-00 Edition) (See also Figure 5).

3/ The use of 3-inch honeycomb is recommended (see Figure 5).

Table 4 - Pendulum Velocity Change - Time Corridor
for Neck Certification Test

Upper Boundary		Lower Boundary	
Time (s)	Velocity (m/s)	Time (s)	Velocity (m/s)
0.001	0.0	0	-0.05
0.003	-0.25	0.0025	-0.375
0.014	-3.2	0.0135	-3.7
		0.017	-3.7

5.6.6. The maximum head-form flexion angle relative to the pendulum (Angle $d\theta A + d\theta C$ in Figure 6) should be between and including 49.0 and 59.0 degrees and should occur between and including 54.0 and 66.0 ms.

5.6.7. The maximum head-form centre of gravity displacements measured in angle $d\theta A$ and $d\theta B$ (see Figure 6) should be: Fore pendulum base angle $d\theta A$ between and including 32.0 and 37.0 degrees occurring between and including 53.0 and 63.0 ms and aft pendulum base angle $d\theta B$ between and including $0.81 * (\text{angle } d\theta A) + 1.75$ and $0.81 * (\text{angle } d\theta A) + 4.25$ degrees occurring between and including 54.0 and 64.0 ms.

5.6.8. The neck performance can be adjusted by replacing the eight circular section buffers with buffers of another shore hardness.

5.7. Shoulder

5.7.1. The length of the elastic cord should be adjusted so that a force between and including 27.5 and 32.5 N applied in a forward direction 4 ± 1 mm from the outer edge of the clavicle in the same plane as the clavicle movement, is required to move the clavicle forward.

5.7.2. The dummy is seated on a flat, horizontal, rigid surface with no back support. The thorax is positioned vertically and the arms should be set at an angle of 40 ± 2 degrees forward to the vertical. The legs are positioned horizontally.

5.7.3. The impactor is a pendulum with a mass of 23.4 ± 0.2 kg and diameter of 152.4 ± 0.25 mm with an edge radius of 12.7 mm ^{4/}. The impactor is suspended from rigid hinges by four wires with the centre line of the impactor at least 3.5 m below the rigid hinges (see Figure 4).

5.7.4. The impactor is equipped with an accelerometer sensitive in the direction of impact and located on the impactor axis.

5.7.5. The impactor should freely swing onto the shoulder of the dummy with an impact velocity of 4.3 ± 0.1 m/s.

^{4/} Pendulum corresponding with American Code of Federal Regulation 49 CFR Chapter V Part 572.36(a) (10-1-00 Edition) (See also Figure 4).

- 5.7.6. The impact direction is perpendicular to the anterior-posterior axis of the dummy and the axis of the impactor coincides with the axis of the upper arm pivot.
- 5.7.7. The peak acceleration of the impactor, filtered using ISO 6487:2000 CFC 180, should be between and including 7.5 and 10.5 g.
- 5.8. Arms
- 5.8.1. No dynamic certification procedure is defined for the arms.
- 5.9. Thorax
- 5.9.1. Each rib module is certified separately.
- 5.9.2. The rib module is positioned vertically in a drop test rig and the rib cylinder is clamped rigidly onto the rig.
- 5.9.3. The impactor is a free fall mass of 7.78 ± 0.01 kg with a flat face and a diameter of 150 ± 2 mm.
- 5.9.4. The centre line of the impactor should be aligned with the centre line of the rib's guide system.
- 5.9.5. The impact severity is specified by the drop heights of 815, 204 and 459 mm. These drop heights result in velocities of approximately 4, 2 and 3 m/s respectively. Impact drop heights should be applied with an accuracy of 1 per cent.
- 5.9.6. The rib displacement should be measured, for instance using the rib's own displacement transducer.
- 5.9.7. The rib certification requirements are given in Table 5 of this annex.
- 5.9.8. The performance of the rib module can be adjusted by replacing the tuning spring inside the cylinder with one of a different stiffness.

Table 5 - Requirements for Full Rib Module Certification

Test sequence	Drop height (accuracy 1%) (mm)	Minimum Displacement (mm)	Maximum Displacement (mm)
1	815	46.0	51.0
2	204	23.5	27.5
3	459	36.0	40.0

- 5.10. Lumbar spine
- 5.10.1. The lumbar spine is mounted to the special certification head-form with a mass of 3.9 ± 0.05 kg (see Figure 6), with the help of a 12 mm thick interface plate with a mass of 0.205 ± 0.05 kg.
- 5.10.2. The head-form and lumbar spine are mounted upside-down to the bottom of a neck-pendulum 5/ allowing a lateral motion of the system.
- 5.10.3. The neck-pendulum is equipped with an uni-axial accelerometer according to the neck pendulum specification (see Figure 5).
- 5.10.4. The neck-pendulum should be allowed to fall freely from a height chosen to achieve an impact velocity of 6.05 ± 0.1 m/s measured at the pendulum accelerometer location.
- 5.10.5. The neck-pendulum is decelerated from impact velocity to zero by an appropriate device 6/, as described in the neck pendulum specification (see Figure 5), resulting in a velocity change - time history inside the corridor specified in Figure 8 and Table 6 of this annex. All channels have to be recorded according to the ISO 6487:2000 or SAE J211 (March 1995) data channel recording specification and filtered digitally using ISO 6487:2000 CFC 180.

Table 6 - Pendulum Velocity Change - Time Corridor
for Lumbar Spine Certification Test

Upper Boundary		Lower Boundary	
Time [s]	Velocity [m/s]	Time [s]	Velocity [m/s]
0.001	0.0	0	-0.05
0.0037	-0.2397	0.0027	-0.425
0.027	-5.8	0.0245	-6.5
		0.03	-6.5

- 5.10.6. The maximum head-form flexion angle relative to the pendulum (Angle $d\theta A + d\theta C$ in Figure 6) should be between and including 45.0 and 55.0 degrees and should occur between and including 39.0 and 53.0 ms.
- 5.10.7. The maximum head-form centre of gravity displacements measured in angle $d\theta A$ and $d\theta B$ (see Figure 6) should be: Fore pendulum base angle $d\theta A$ between and including 31.0 and 35.0 degrees occurring between and including 44.0 and 52.0 ms and aft pendulum base angle $d\theta B$ between and including $0.8 * (\text{angle } d\theta A) + 2.00$ and $0.8 * (\text{angle } d\theta A) + 4.50$ degrees occurring between and including 44.0 and 52.0 ms.
- 5.10.8. The performance of the lumbar spine can be adjusted by changing tension in the spine cable.

5/ Neck pendulum corresponding with American Code of Federal Regulation 49 CFR Chapter V Part 572.33 (10-1-00 Edition) (See also Figure 5).

6/ The use of 6-inch honeycomb is recommended (see Figure 5).

5.11. Abdomen

- 5.11.1. The dummy is seated on a flat, horizontal, rigid surface with no back support. The thorax is positioned vertically, while the arms and legs are positioned horizontally.
- 5.11.2. The impactor is a pendulum with a mass of 23.4 ± 0.2 kg and diameter of 152.4 ± 0.25 mm with an edge radius of 12.7 mm 7/. The impactor is suspended from rigid hinges by eight wires with the centre line of the impactor at least 3.5 m below the rigid hinges (see Figure 4).
- 5.11.3. The impactor is equipped with an accelerometer sensitive in the direction of impact and located on the impactor axis.
- 5.11.4. The pendulum is equipped with a horizontal "arm rest" impactor face of 1.0 ± 0.01 kg. The total mass of the impactor with the arm rest face is 24.4 ± 0.21 kg. The rigid "arm rest" is 70 ± 1 mm high, 150 ± 1 mm wide and should be allowed to penetrate at least 60 mm into the abdomen. The centreline of the pendulum coincides with the centre of the "arm rest".
- 5.11.5. The impactor should freely swing onto the abdomen of the dummy with an impact velocity of 4.0 ± 0.1 m/s.
- 5.11.6. The impact direction is perpendicular to the anterior-posterior axis of the dummy and the axis of the impactor is aligned with the centre of the middle abdominal force transducer.
- 5.11.7. The peak force of the impactor, obtained from the impactor acceleration filtered using ISO 6487:2000 CFC 180 and multiplied by the impactor/armrest mass, should be between and including 4.0 and 4.8 kN, and occur between and including 10.6 and 13.0 ms.
- 5.11.8. The force-time histories measured by the three abdominal force transducers must be summed and filtered using ISO 6487:2000 CFC 600. The peak force of this sum should be between and including 2.2 and 2.7 kN, and occur between and including 10.0 and 12.3 ms.

5.12. Pelvis

- 5.12.1. The dummy is seated on a flat, horizontal, rigid surface with no back support. The thorax is positioned vertically while the arms and legs are positioned horizontally.
- 5.12.2. The impactor is a pendulum with a mass of 23.4 ± 0.2 kg and diameter of 152.4 ± 0.25 mm with an edge radius of 12.7 mm 8/. The impactor is suspended from rigid hinges by eight wires with the centre line of the impactor at least 3.5 m below the rigid hinges (see Figure 4).

7/ Pendulum corresponding with American Code of Federal Regulation 49 CFR Chapter V Part 572.36(a) (10-1-00 Edition) (See also Figure 4).

8/ Pendulum corresponding with American Code of Federal Regulation 49 CFR Chapter V Part 572.36(a) (10-1-00 Edition) (See also Figure 4).

- 5.12.3. The impactor is equipped with an accelerometer sensitive in the direction of impact and located on the impactor axis.
- 5.12.4. The impactor should freely swing onto the pelvis of the dummy with an impact velocity of 4.3 ± 0.1 m/s.
- 5.12.5. The impact direction is perpendicular to the anterior-posterior axis of the dummy and the axis of the impactor is aligned with the centre of the H-point back plate.
- 5.12.6. The peak force of the impactor, obtained from the impactor acceleration filtered using ISO 6487:2000 CFC 180 and multiplied by the impactor mass, should be between and including 4.4 and 5.4 kN, and occur between and including 10.3 and 15.5 ms.
- 5.12.7. The pubic symphysis force, filtered using ISO 6487:2000 CFC 600, should be between and including 1.04 and 1.64 kN and occur between and including 9.9 and 15.9 ms.
- 5.13. Legs
- 5.13.1. No dynamic certification procedure is defined for the legs.

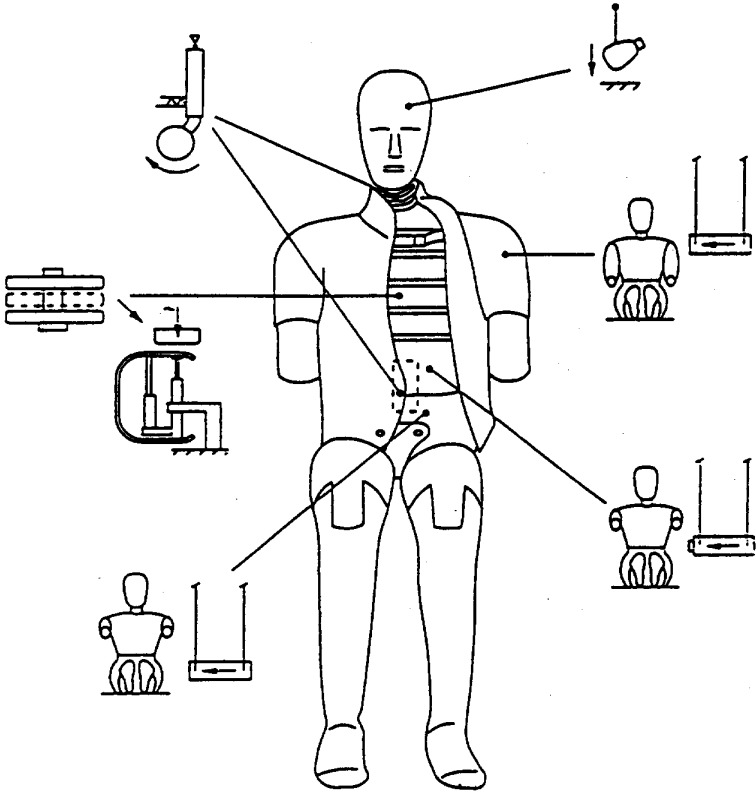

Figure 3 - Overview of dummy certification test set-up

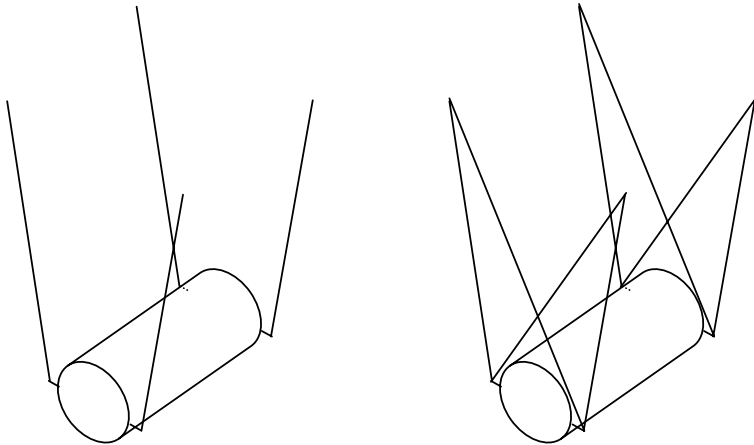

Figure 4 - 23.4 kg Pendulum impactor suspension
left: four wires suspension (cross wires removed)
right: eight wires suspension

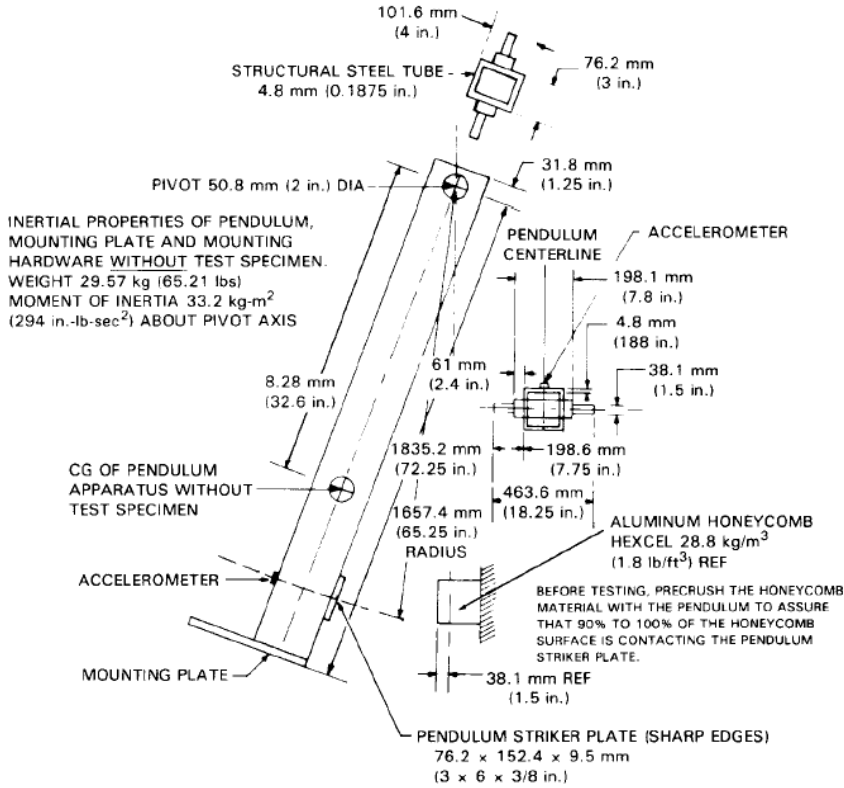

Figure 5 - Neck pendulum specification according to American Code of Federal Regulation (49 CFR Chapter V Part 572.33)

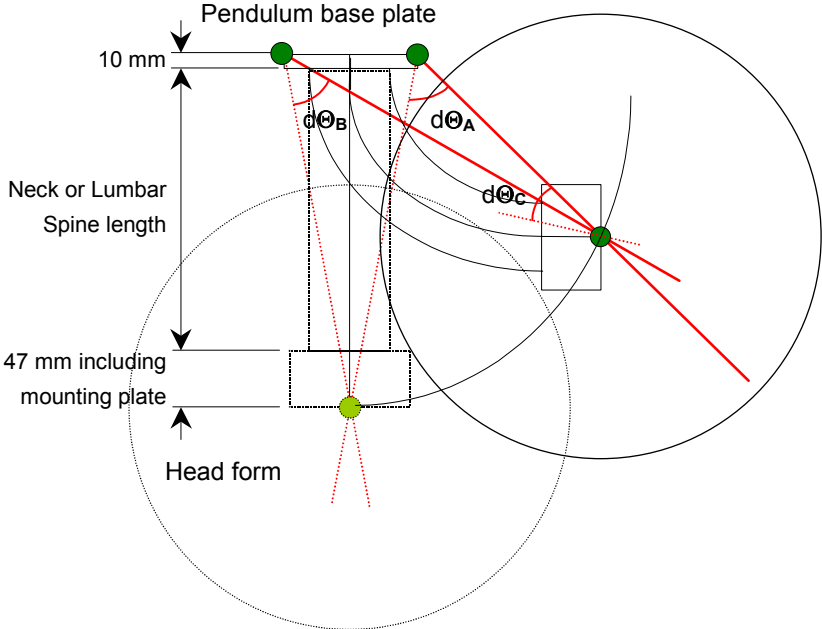

Figure 6 - Neck and lumbar spine certification test set-up (Angles $d\theta_A$, $d\theta_B$ and $d\theta_C$ measured with head-form)

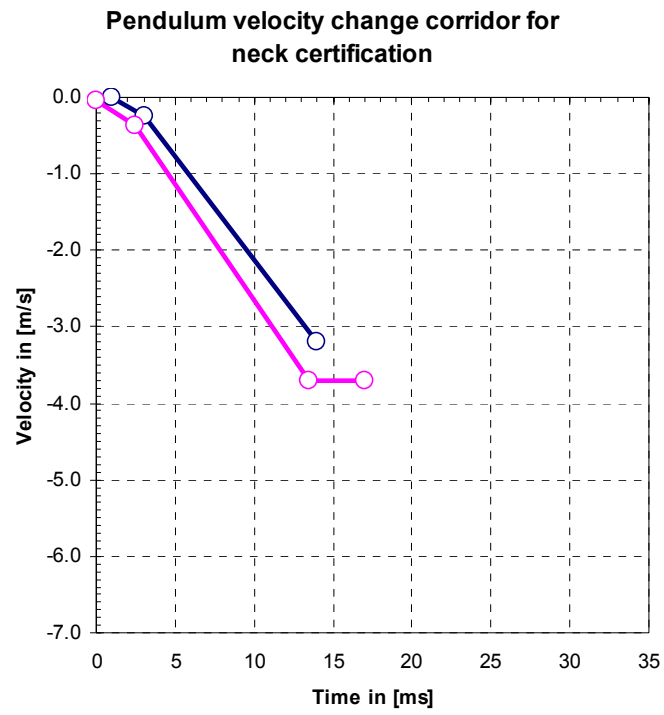

Figure 7 - Pendulum velocity change - time corridor
for neck certification test

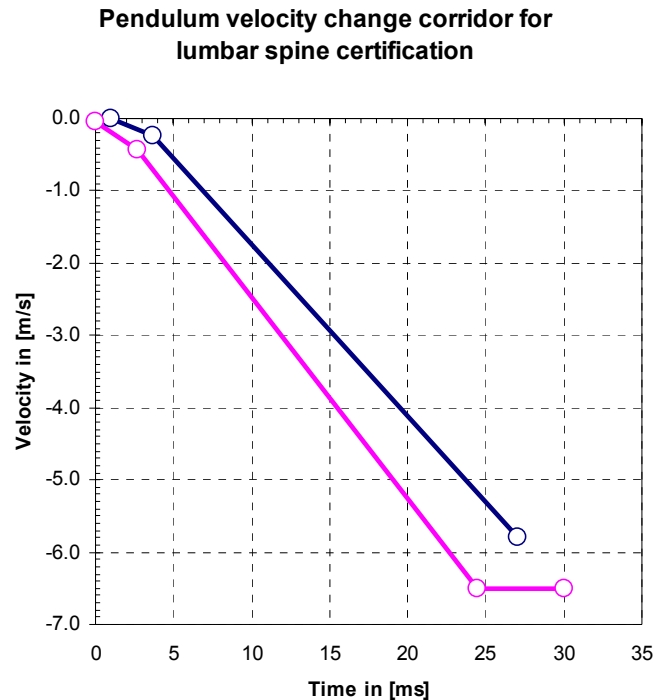

Figure 8 - Pendulum velocity change - time corridor for lumbar spine certification test"

Annex 7, amend to read:

"Annex 7

INSTALLATION OF THE SIDE IMPACT DUMMY

1. GENERAL

1.1. The side impact dummy as described in annex 6 of this Regulation is to be used according the following installation procedure.

2. INSTALLATION

2.1. Adjust the knee and ankle joints so that they just support the lower leg and the foot when extended horizontally (1 to 2 g - adjustment).

2.2. Check if the dummy is adapted to the desired impact direction.

2.3. The dummy shall be clothed in a form-fitting cotton stretch mid-calf length pant and may be clothed in a form-fitting cotton stretch shirt with short sleeves.

2.4. Each foot shall be equipped with a shoe.

- 2.5. Place the dummy in the outboard front seat on the impacted side as described in the side impact test procedure specification.
- 2.6. The plane of symmetry of the dummy shall coincide with the vertical median plane of the specified seating position.
- 2.7. The pelvis of the dummy shall be positioned such that a lateral line passing through the dummy H-points is perpendicular to the longitudinal centre plane of the seat. The line through the dummy H-points shall be horizontal with a maximum inclination of ± 2 degrees ^{9/}.

The correct position of the dummy pelvis can be checked relative to the H-point of the H-point Manikin by using the M3 holes in the H-point back plates at each side of the ES-2 pelvis. The M3 holes are indicated with "Hm". The "Hm" position should be in a circle with a radius of 10 mm round the H-point of the H-point Manikin.

- 2.8. The upper torso shall be bent forward and then laid back firmly against the seat back (see note 9). The shoulders of the dummy shall be set fully rearward.
- 2.9. Irrespective of the seating position of the dummy, the angle between the upper arm and the torso arm reference line on each side shall be 40 ± 5 degrees. The torso arm reference line is defined as the intersection of the plane tangential to the front surface of the ribs and the longitudinal vertical plane of the dummy containing the arm.
- 2.10. For the driver's seating position, without inducing pelvis or torso movement, place the right foot of the dummy on the non-depressed accelerator pedal with the heel resting as far forward as possible on the floor-pan. Set the left foot perpendicular to the lower leg with the heel resting on the floor-pan in the same lateral line as the right heel. Set the knees of the dummy such that their outside surfaces are 150 ± 10 mm from the plane of symmetry of the dummy. If possible within these constraints, place the thighs of the dummy in contact with the seat cushion.
- 2.11. For other seating positions, without inducing pelvis or torso movement, place the heels of the dummy as far forward as possible on the floor-pan without compressing the seat cushion more than the compression due to the weight of the leg. Set the knees of the dummy such that their outside surfaces are 150 ± 10 mm from the plane of symmetry of the dummy."

^{9/} The dummy can be equipped with tilt sensors in the thorax and the pelvis. These instruments can help to obtain the desired position.