



**Economic and Social
Council**

Distr.
GENERAL

TRANS/WP.29/GRSG/63
4 July 2003

Original: ENGLISH

ECONOMIC COMMISSION FOR EUROPE

INLAND TRANSPORT COMMITTEE

World Forum for Harmonization of Vehicle Regulations (WP.29)

Working Party on General Safety Provisions (GRSG)

REPORT OF THE WORKING PARTY ON GENERAL SAFETY PROVISIONS (GRSG)
ON ITS EIGHTY-FOURTH SESSION

(5 to 9 May 2003)

1. GRSG held its eighty-fourth session from 5 May (afternoon) 2003 to 9 May 2003, under the chairmanship of Mr. A. Erario (Italy). Experts from the following countries participated in the work, following Rule 1(a) of the Rules of Procedure of WP.29 (TRANS/WP.29/690): Belgium; Canada; Czech Republic; Denmark; Finland; France; Germany; Hungary; Italy; Japan; Netherlands; Norway; Poland; Russian Federation; Spain; United Kingdom; United States of America. A representative of the European Commission (EC) participated. Experts from the following non-governmental organizations took part in the session: International Road Transport Union (IRU); International Organization of Motor Vehicle Manufacturers (OICA); International Motorcycle Manufacturers Association (IMMA); European Association of Automobile Suppliers (CLEPA).
2. The documents without a symbol distributed during the session are listed in annex 1 to this report.

DEVELOPMENT OF REGULATION No. 36 (Large capacity passenger vehicles)

Documentation: TRANS/WP.29/GRSG/2003/14; TRANS/WP.29/GRSG/2003/15; informal document No. 12 of annex 1 to this report.

3. GRSG considered and adopted the proposal of document TRANS/WP.29/GRSG/2003/14, with the square brackets being deleted, and agreed to transmit it to WP.29 and AC.1 for consideration at their November 2003 sessions as draft Supplement 9 to the 03 series of amendments to Regulation No. 36.

4. GRSG also adopted TRANS/WP.29/GRSG/2003/15, related to Regulations Nos. 36, 52 and 107, and agreed to transmit the document, amended as indicated below, to WP.29 and AC.1 for consideration at their November 2003 sessions as part of draft Supplement 9 to the 03 series of amendments to Regulation No. 36, draft Supplement 6 to the 01 series of amendments to Regulation No. 52, and draft Supplement 5 to Regulation No.107.

The amended paragraph 5.6.10.9., amend the word "from" to read "relative to".

5. The expert from Germany introduced informal document No. 12. At the request of several experts, asking for more time to consider the proposal, GRSG requested the secretariat to distribute informal document No. 12 with an official symbol at the October 2003 session.

DEVELOPMENT OF REGULATION No. 52 (Small capacity passenger vehicles, M2 and M3 category)

Documentation: TRANS/WP.29/GRSG/2002/6; TRANS/WP.29/GRSG/2003/2; TRANS/WP.29/GRSG/2003/15; informal documents Nos. 13 and 18 of annex 1 to this report.

6. GRSG adopted the proposal of informal document No. 18, which superseded document TRANS/WP.29/GRSG/2002/6. It was agreed to transmit the proposal, as reproduced in annex 2 to this report, to WP.29 and AC.1 for consideration at their November 2003 sessions as part of draft Supplement 6 to the 01 series of amendments to Regulation No. 52 (see para. 4 above).

7. The expert from Spain introduced TRANS/WP.29/GRSG/2003/2. GRSG agreed to renumber Figures 21 and 22 to read Figures 20 and 21 respectively. The experts from Poland and the Russian Federation requested clarification for the position of the driver's seat and wondered if the test should be conducted in the worst possible position. To clarify the text, the expert from the United Kingdom suggested amending paragraph 5.7.2.4.2., as reproduced below. Following the discussion, GRSG agreed to resume consideration of the proposal at its next session.

Paragraph 5.7.2.4.2., amend to read:

" indicated in paragraph 5.6.2.5.2. and that the space reserved for the driver's seat shall communicate with the main passengers' compartment through an appropriate passage; such requirement shall be deemed to be fulfilled if the test gauge described in paragraph 5.7.5.1. can move unobstructed from the gangway, until the front end of the gauge reaches the vertical plane tangential to the foremost point of the driver's seat back (this seat being situated in its rearmost longitudinal position) and, from this plane, the panel described in

paragraph 5.6.2.5.2. could be moved to the emergency door in the direction established by such paragraph (see annex 3, figure 21) with seat and steering wheel adjustment in their mid position."

8. GRSG noted that document TRANS/WP.29/GRSG/2003/15 had been adopted when considering Regulation No. 36 (see para. 4).

9. For the same reason as for the parallel proposal for Regulation No. 36 (see para. 5), the secretariat was requested to distribute informal document No. 13 with an official symbol at the October 2003 session.

DEVELOPMENT OF REGULATION No. 107 (Double-deck large passenger vehicles)

Documentation: TRANS/WP.29/GRSG/2003/5; TRANS/WP.29/GRSG/2003/15; TRANS/WP.29/GRSG/2003/16; informal documents Nos. 6, 14, 19, 23, and 24 of annex 1 to this report.

10. As agreed during the previous session (TRANS/WP.29/GRSG/62, para. 9), GRSG considered the consolidation of Regulations Nos. 36, 52 and 107 as a revision of Regulation No. 107 (TRANS/WP.29/GRSG/2003/5). The expert from OICA introduced informal document No. 19 incorporating the new prescriptions for manoeuvrability from the European Union Directive 2003/19/EC. The expert from the Netherlands tabled informal document No. 23 containing amendments to the proposal. When considering the proposal, the expert from the United Kingdom insisted on having the same derogation that his country and Portugal were granted on the manoeuvrability by article 4 of the European Union Directive 2003/19/EC. Following a detailed discussion, informal document No. 24 was tabled containing all the amendments adopted by GRSG, including a solution to the manoeuvrability issue by allowing the type approval of vehicles according to two alternative methods, but that only Portugal and the United Kingdom would be allowed to grant approval under the alternative containing the same derogation than the Directive (alternative B). GRSG clarified that Contracting Parties were allowed to not accept, for registration in their territory, vehicles type-approved under the alternative they would not make use of. As regards the extension of the derogation, GRSG agreed that the Regulation would follow the decision to be adopted by the European Community. Under this premise, GRSG adopted document TRANS/WP.29/GRSG/2003/5 as modified by informal document No. 24, which was also amended. The amendments to the original proposal adopted are reproduced in annex 3 to this report. GRSG agreed to transmit the amended proposal to WP.29 and AC.1 for consideration at their November 2003 sessions as draft 01 series of amendments to Regulation No. 107.

11. GRSG noted that document TRANS/WP.29/GRSG/2003/15 had been adopted when considering Regulation No. 36 (see para. 4).

12. GRSG adopted document TRANS/WP.29/GRSG/2003/16 and agreed to transmit it to WP.29 and AC.1 for consideration at their November 2003 sessions as a part of draft Supplement 5 to Regulation No. 107 (see para. 4).

Note by the secretariat: Due to the adoption of the proposal for the draft 01 series of amendments to Regulation No. 107 (see para. 10. above), the secretariat will suggest to WP.29/AC.2 to delay the

adoption of the above-mentioned draft Supplement 5 to Regulation No. 107 (see paras. 4 and 12) to a further session as draft Supplement 1 to the 01 series of amendments to Regulation No. 107.

13. The expert from Germany introduced informal document No. 6 in which he requested the guidance of GRSG for the introduction of requirements for the driver's field of vision for M2 and M3 vehicles, including sight requirements for the transport of pupils, in the revised Regulation No. 107, in the draft Regulation concerning the driver's field of vision, or to keep national legislations covering this issue. GRSG expressed its preference for incorporating these prescriptions into the draft Regulation concerning the driver's field of vision, and the expert from Germany announced the submission of a corresponding proposal for the GRSG October 2003 session.

14. For the same reason as for the parallel proposal for Regulation No. 36 (see para. 5), the secretariat was requested to distribute informal document No. 14 with an official symbol at the October 2003 session.

15. The expert from the United Kingdom informed GRSG that his country had conducted a research on passengers' safety on buses when using wheelchairs and that a report had been elaborated containing a series of recommendations. He offered to communicate to the secretariat the web address where the report could be found. He suggested the creation of an informal group to deal with this issue. GRSG experts welcomed this suggestion and the experts from France, Germany, the Netherlands, Italy, Norway, Poland, Spain, and OICA announced their interest in participating in the informal group. The Chairman announced his intention to request the consent of WP.29 for this informal group at its June 2003 session.

Note by the secretariat: The web address for the report is:

<http://www.mobility-unit.dft.gov.uk/wheelchair-occupants/pdf/wheelchair.pdf>

The report is also available at the GRSG web page under "informal documents – 84th session".

DEVELOPMENT OF REGULATION No. 66 (Strength of superstructure)

Documentation: informal documents Nos. 4, 5 and 7 of annex 1 to this report.

16. The expert from Hungary, Chairman of the informal group on developing Regulation No. 66, reported to GRSG about the progress made during the meeting, which had been held in Warsaw on 28 and 29 October 2002 (informal document No. 5). He said that informal document No. 7 contained the output of the work of the informal group as a revision of Regulation No. 66. The expert from Spain pointed out that the proposal was a compromise and thanked Mr. Matolcsy for his efforts. Mr. Matolcsy thanked the experts from Poland and the United Kingdom for their collaboration in drafting the final document.

17. The expert from Hungary introduced informal document No. 4 and indicated that it should be considered as a conclusion of the data about rollover accidents he had presented at the previous meetings. He informed GRSG, jointly with the expert from the Czech Republic, about the accident of March 2003, and offered to provide further information during the next GRSG session. The issue of the rollover of double deck vehicles, as well as the so-called high vehicles, was raised again. Nevertheless, GRSG considered, as its first priority, to conclude the revision of the Regulation based on the proposal by the informal group (informal document No. 7). GRSG requested the secretariat to

distribute a corrected version of informal document No. 7, to be provided by the expert from Hungary, with an official symbol for consideration at the next GRSG session.

18. The expert from Spain informed GRSG that, in his opinion, and after the entry into force of Regulation No. 66, frontal impact accidents were the most important cause of the fatalities on coach accidents. He announced his intention to carry out a research study on this issue and invited any interested GRSG experts to communicate to him their willingness to participate in the work.

REGULATION No. 43 (Safety glazing)

(a) Development

Documentation: TRANS/WP.29/GRSG/2003/3; TRANS/WP.29/GRSG/2003/6; TRANS/WP.29/GRSG/2003/13; informal document No. 10 of annex 1 to this report.

19. GRSG adopted TRANS/WP.29/GRSG/2003/6 and agreed to transmit it to WP.29 and AC.1 for consideration at their November 2003 sessions as draft Supplement 8 to Regulation No. 43.

20. The expert from the European Commission introduced his proposal to identify, with an additional symbol, safety glazing with a regular light transmittance of less than 40 per cent (TRANS/WP.29/GRSG/2003/3). The expert from CLEPA presented TRANS/WP.29/GRSG/2003/13 containing the reasons, why such identification was not necessary. The experts from Belgium, Canada, Denmark, Finland, the Netherlands, and the United States of America supported the proposal tabled by the European Commission. The experts from France, Germany, Japan, Italy, OICA and CLEPA opposed it. The experts from the Czech Republic, Norway, Poland, and the Russian Federation initially expressed their intention to follow the majority but, after noting the opinions, they explicitly expressed their support to the proposal transmitted by the expert from the European Commission. The expert from Spain announced that he would also follow the majority and the experts from Hungary, the United Kingdom, and IRU indicated their abstention. At the persistence of the expert from the European Commission and despite the opposition and abstentions expressed before, GRSG agreed to transmit the proposal of TRANS/WP.29/GRSG/2003/3 to WP.29 and AC.1 for consideration at their November 2003 sessions as part of draft Supplement 8 to Regulation No. 43. In order to avoid a possible blockage of the proposal adopted under paragraph 19, GRSG agreed with the secretariat's suggestion not to consolidate both proposals, but to transmit them separately.

21. The expert from the Netherlands withdrew informal document No. 10.

(b) Draft global technical regulation (gtr)

Documentation: Informal document No. 16 of annex 1 to this report.

22. The expert from Germany informed GRSG about the progress of the work of the group developing the gtr, that had met prior to the GRSG session. He expressed his expectation to submit a document for consideration at the next GRSG session in October 2003.

DRAFT REGULATION ON THE PROTECTION OF M1 AND M2 CATEGORIES OF VEHICLES AGAINST UNAUTHORIZED USE (Development)

23. GRSG did not consider this item, awaiting the result of the proposal for Regulation No. 97 (see para. 24 below).

DEVELOPMENT OF REGULATION No. 97 (Vehicle alarm systems)

Documentation: TRANS/WP.29/GRSG/2003/8.

24. The expert from Germany introduced a proposal for vehicle degradation systems (TRANS/WP.29/GRSG/2003/8) and explained that he had taken into account a former proposal by the United Kingdom. Several experts made comments on the document, and the expert from Germany volunteered to transmit an updated proposal, taking into consideration the comments raised, for consideration at the next session.

DEVELOPMENT OF REGULATION No. 34 (Prevention of fire risks)

Documentation: TRANS/WP.29/GRSG/2003/4; TRANS/WP.29/GRSG/2003/7; informal document No. 2 of annex 1 to this report.

25. GRSG considered and rejected the proposal contained in TRANS/WP.29/GRSG/2003/4.

26. GRSG adopted the proposal of TRANS/WP.29/GRSG/2003/7 and agreed to transmit it to WP.29 and AC.1 for consideration at their November 2003 sessions as draft Supplement 1 to the 02 series of amendments to Regulation No. 34.

27. The expert from Germany introduced informal document No. 2 dealing with ignition hazards for fuel and hot diesel fuel vapours in and around tank systems due to electrostatic discharges. He said that the increased use of plastic materials in vehicles could increase the ignition hazards. He said that the main conclusion of the document was that the current provision of the Regulation, related to the avoidance of the accumulation of the static electricity charge in the fuel tank and in the filler neck, was too restrictive and requested the GRSG experts to study this issue carefully.

DEVELOPMENT OF REGULATION No. 46 (Rear-view mirrors)

Documentation: TRANS/WP.29/GRSG/2002/10; TRANS/WP.29/GRSG/2003/9 informal documents Nos. 3, 15, and 16 of annex 1 to this report.

28. The expert from the Netherlands informed GRSG that the European Parliament had not yet completed its second reading of the draft European Community Directive and offered to update his proposal (TRANS/WP.29/GRSG/2002/10) accordingly with possible changes in the process of its adoption by the European Community. In addition, he proposed to refer to the final version of the ISO Standard (paras. 6.2.2.2.2. and 6.2.2.2.4.) and to review the last sentence of paragraph 15.2.4.8.1. because it had been deleted when adopting the 01 series of amendments to the Regulation (informal document No. 3).

29. The expert from Germany informed GRSG that the two proposals suggested by the expert from the Netherlands were included, among others, in his proposal (TRANS/WP.29/GRSG/2003/9), although he recommended not considering this proposal, awaiting the final text of the Directive.

30. The expert from Japan introduced informal document No. 16 which contained the draft Japanese regulation concerning the driver's field of vision on immediate frontward and sideward. He said that this regulation should be published in few months. He requested GRSG that the proposed amendments to Regulation No. 46 should take into consideration the more stringent requirements of the Japanese draft for rear view mirrors and also asked the experts to study carefully the document and to check the differences between this Japanese regulation and Regulation No. 46.

31. Informal document No. 15, containing information about low-speed accidents caused by relatives or close associates, was also introduced by the expert from Japan. The Chairman asked the experts to study the document and come back with their comments for the October 2003 session.

DRAFT GLOBAL TECHNICAL REGULATION ON COMMON DEFINITIONS AND PROCEDURES

Documentation: TRANS/WP.29/GRSG/2003/10; informal documents Nos. 9, 11, 17, 21, 25, and 26 of annex 1 to this report.

32. The expert from Japan recalled the AC.3 agreement that the proposal for common definitions and procedures (TRANS/WP.29/GRSG/2003/10) could not be a global technical regulation (gtr) and that AC.3 had considered as possibilities to insert it in a resolution referring to the 1998 Agreement, or even in Consolidated Resolution R.E.3 (TRANS/WP.29/909, para. 140). The expert also suggested that the proposal could also be attached to each gtr and asked for the experts' advice. At the suggestion of the expert from the United Kingdom, GRSG agreed that whichever solution was adopted, it must have a legal implication for the Contracting Parties to the 1998 Agreement, it should be possible to amend it easily, and it should concentrate all the definitions in one set. The expert from Canada suggested that the document should include reference to the guidelines regarding proposing and developing of global technical regulations (TRANS/WP.29/882) and to the format of global technical regulations (TRANS/WP.29/882).

33. GRSG made a first reading of TRANS/WP.29/GRSG/2003/10, jointly with informal documents Nos. 9, 11, 17, 21, 25, and 26 transmitted by several experts proposing amendments to the document. Several amendments were accepted and GRSG agreed to continue consideration of a revised proposal, if possible with the new format to be specified by WP.29 and AC.3, at the October 2003 session.

OTHER BUSINESS

(a) Draft global technical regulation on identification of controls, tell-tales and indicators

Documentation: TRANS/WP.29/GRSG/2000/8/Rev.2; informal document No. 22 of annex 1 to this report.

34. The expert from Canada introduced informal document No. 22 containing amendments to TRANS/WP.29/GRSG/2000/8/Rev.2. He explained the main amendments and suggested to distribute informal document No. 22 with an official symbol for the October 2003 session.

35. The expert from France indicated that the equivalent draft Regulation under the 1958 Agreement would differ from the draft gtr and suggested to align the draft gtr to the draft Regulation. Recognizing the differences between both proposals, GRSG agreed to consider this issue at a later stage.

(b) Draft Regulation on the driver's field of vision

Documentation: TRANS/WP.29/GRSG/2000/19/Rev.1; TRANS/WP.29/GRSG/2002/1; TRANS/WP.29/GRSG/2002/9.

36. As agreed at the previous session (TRANS/WP.29/GRSG/62, para. 28), GRSG considered the proposal for a draft Regulation based totally on the prescriptions of the equivalent European Community Directive (TRANS/WP.29/GRSG/2000/19/Rev.1). GRSG became aware of several divergences from the Directive and decided that an amended proposal should be considered at the October session. GRSG also agreed to resume consideration of the proposals of documents TRANS/WP.29/GRSG/2002/1 and TRANS/WP.29/GRSG/2002/9 at its next session.

(c) Fire extinguishers

37. The Chairman recalled that WP.29 had requested GRSG to include in its programme of work measures concerning the fire extinguishing devices (TRANS/WP.29/841, paras. 27 and 28). He also recalled the presentations made by different experts about national legislation on fire extinguishers, and that Regulations Nos. 36, 52 and 107 contained prescriptions for the space to be provided for the installation of fire extinguishers. It was also noted that any Regulation under the 1958 Agreement contained fire extinguishers prescriptions. The Chairman announced his intention to report back to WP.29 and request more detailed instructions for further actions by GRSG, if needed. He suggested maintaining this item on the agenda for the next session.

(d) New draft Regulation concerning heating systems.

Documentation: TRANS/WP.29/GRSG/2002/11 and Add. 1; informal document No. 20 of annex 1 to this report.

38. The expert from OICA introduced the proposals, explaining to GRSG that the three documents, TRANS/WP.29/GRSG/2002/11 and Add. 1 and informal document No. 20, were a unique set. The experts from the European Commission and the Netherlands informed GRSG that a working group had been set up in Brussels to consider the automatic "switch off" of the heating system

(para. 5.3.8.1.). They requested to postpone the consideration of the proposal to the October 2003 session. Nevertheless, GRSG considered the proposal and in principle agreed the following amendments:

Annex 5,

Paragraph 2., amend to read:

" any driver of the vehicle "

Paragraph 2.1., amend to read:

"2.1. In the case of part or parts of the heating system behind the driver's seat, and in the case of overheating, the temperature shall not exceed 110°C."

Annex 8, correct the reference to "paragraph 6.2.2." to read "paragraph 6.2.1."

39. The secretariat was requested to check if the provisions for the marking (paras. 4.2. and 4.5.) were in line with the 1958 Agreement and to propose, if needed, the necessary amendments to them. Having noted that the new prescriptions for the European Agreement concerning the International Carriage of Dangerous Goods by Road (ADR) would enter into force on 1 January 2005, GRSG requested the expert from the European Commission to transmit a proposal for the controversial paragraph (see para. 38 above) and agreed to adopt, in any case, the proposal at its October 2003 session.

(e) Regulation No. 26 (Vehicles with regard their external projections)

Documentation: TRANS/WP.29/GRSG/2003/11.

40. The expert from the Netherlands introduced TRANS/WP.29/GRSG/2003/11 with an amendment to the Regulation. The expert from Japan requested to have a cost benefit analysis and/or accident data justifying the proposed amendment. The expert from France offered to prepare a complementary proposal in order to include the aerials of Global Positioning Systems (GPS), and the expert from OICA volunteered to transmit a proposal for transitional provisions. Awaiting the announced proposals, GRSG agreed to resume their consideration at its next session.

(f) Regulation No. 60 (Driver-operated controls)

Documentation: TRANS/WP.29/GRSG/2003/12.

41. GRSG considered and adopted TRANS/WP.29/GRSG/2003/12. The secretariat was requested to transmit it to WP.29 and AC.1 for consideration at their November 2003 sessions as draft Supplement 2 to Regulation No. 34.

- (g) Draft Regulation concerning the burning behaviour of materials used in the interior of certain categories of motor vehicles

Documentation: TRANS/WP.29/2002/73.

42. GRSG considered the proposal of TRANS/WP.29/2002/73 and adopted only the proposals to amend paragraphs 6.1.2., annex 6, paragraphs 1.2., 1.3., 2.2., 4.5., and 4.7., and annex 8 paragraph 4.1. GRSG also agreed to transmit the amended proposal to WP.29 and AC.1 for consideration at their November 2003 sessions. In order to avoid any delay in adopting the draft Regulation, the secretariat suggested considering it as a corrigendum, only after the draft Regulation (current document TRANS/WP.29/2002/23) was adopted.

- (h) Draft Rule No. 2 - Uniform provisions for periodical technical inspections of wheeled vehicles with regard to their roadworthiness

Documentation: TRANS/WP.29/WP.29/2003/16.

43. GRSG was informed about the decision of WP.29 and AC.3 at their March 2003 sessions (TRANS/WP.29/909, paras. 95 and 98) relating to document TRANS/WP.29/2003/16, proposing a draft Rule No. 2 concerning uniform provisions for the periodical technical inspections of wheeled vehicles with regard to their roadworthiness. GRSG noted that the proposal was similar to the corresponding European Community Directive. The Chairman invited all experts to review the document. GRSG agreed to consider the proposal as well as possible comments from the experts at its October 2003 session.

- (i) Consolidated Resolution on the constructions of vehicles (R.E.3)

44. The secretariat recalled the decision of WP.29 to transmit to GRSG an updated proposal to amend R.E.3 (TRANS/WP.29/885, para. 111). The expert from the Russian Federation agreed to update his proposal and transmit it for consideration at the GRSG October 2003 session.

- (j) Draft Regulation on identification of controls, tell-tales and indicators

Documentation: informal documents Nos. 8 and Add.1 of annex 1 to this report.

45. The expert from OICA introduced informal documents Nos. 8 and 8/Add.1 proposing amendments to the proposal for a new draft Regulation on identification of controls, tell-tales and indicators (TRANS/WP.29/2002/67). GRSG adopted the proposal and requested the secretariat to produce a revised document (TRANS/WP.29/2002/67/Rev.1), with the amendments adopted, and to transmit the revised proposal to WP.29 and AC.1 for consideration at their November 2003 sessions. Given that this agenda item was included at the beginning of the session, the expert from Japan informed GRSG that his country had not had time to fully consider it. For this reason, he raised a study reservation, but announced his intention to define the position of his country at the WP.29 and AC.1 sessions in November 2003.

TRIBUTE TO Mr. J. JERIE

46. The Chairman informed GRSG that Mr. Jan Jerie, Secretary of WP.29 and its subsidiary Working Parties since 1990, was departing at his own request for early retirement at the end of May 2003. He, and all GRSG experts, thanked Mr. Jan Jerie for his exceptional and personal dedication to the work of WP.29 and its subsidiary bodies and wished him a long and happy retirement. Mr. Jerie thanked the experts for their wishes and GRSG honoured him with a long applause.

AGENDA FOR THE NEXT SESSION

47. For its eighty-fifth session to be held in Geneva from 21 (14.30 h) to 24 (12.30 h) October 2003, GRSG agreed on the following provisional agenda 1/ 2/:

1. Regulation No. 36 (Large capacity passenger vehicles), development
2. Regulation No. 52 (Small capacity passenger vehicles, M2 and M3 category), development
3. Regulation No. 107 (Double-deck large passenger vehicles), development
4. Regulation No. 66 (Strength of superstructure), development
5. Safety glazing
 - 5.1. Regulation No. 43, development
 - 5.2. Draft global technical regulation
6. New draft Regulation on the protection of M1 and N1 category vehicles against unauthorized use, development
7. Regulation No. 97 (Vehicle alarm systems), development
8. Regulation No. 46 (Rear view mirrors), development
9. Global definitions on masses and dimensions
10. Other business
 - 10.1. New draft global technical regulation on identification of controls, tell-tales and indicators
 - 10.2. New draft Regulation concerning the driver's field of vision of power driven vehicles

- 10.3. Fire extinguishers (subject to the result of the WP.29 June 2003 session)
 - 10.4. Draft Regulation concerning heating systems
 - 10.5. Periodical technical inspections
 - 10.6. Consolidated Resolution on the Construction of Vehicles (R.E.3), development
-

1/ As part of the secretariat's efforts to reduce expenditure, all the official as well as the informal documents distributed prior to the session by mail or placed on the UNECE web-site, (<http://www.unece.org/trans/main/welcwp29.htm>) will not be available in the conference room for distribution to session participants. Delegates are kindly requested to bring their copies of documents to the meeting.

2/ The numerical order of the agenda items should be followed in order to avoid discontinuity in the participation of experts specialized in various subjects.

Annex 1

LIST OF INFORMAL DOCUMENTS DISTRIBUTED WITHOUT
A SYMBOL DURING THE EIGHTY-THIRD SESSION

<u>No</u>	<u>Transmitted by</u>	<u>Agenda item</u>	<u>Language</u>	<u>Title</u>
1.	Chairman		E	Provisional agenda item running order
2.	Germany	8.	E	Electrostatic ignition hazards in motor cars – occurrence, detection and avoidance
3.	Netherlands	9.	E	Explanatory notes concerning document TRANS/WP.29/GRSG/2002/10
4.	Hungary	4.	E	Lessons and conclusions learned from the analysis of bus rollover accidents
5.	Hungary	4.	E	Report about the ad-hoc expert group (AHEG) meeting dealing with the development of Regulation No. 66
6.	Germany	3.	E	Questions relating to Regulation 107 Rev.1, updated as the "Bus-Regulation" and New draft Regulation concerning the driver's field of vision
7.	Hungary	4.	E	Review and Revision of Regulation No. 66. Consolidated document presenting the completed work of the ad hoc Expert Group
8.	OICA	11.10.	E	OICA Proposal for draft amendments to the draft regulation on hand controls, tell-tales and indicators
8/Add.1.	OICA	11.10.	E	Amendment to the OICA proposal (Informal document No. 8) for amendments to the draft regulation on hand controls, tell-tales and indicators
9.	OICA	10.	E	OICA proposal for a draft amendment to document TRANS/WP.29/GRSG/2003/10 (draft GTR on masses and dimensions)

<u>No</u>	<u>Transmitted by</u>	<u>Agenda item</u>	<u>Language</u>	<u>Title</u>
10.	Netherlands	5.1.	E	Proposal to amend Regulation 43 on safety glazing
11.	Netherlands	10.	E	Comments to gtr-0 (Document TRANS/WP.29/GRSG/2003/10)
12.	Germany	1.	E	Proposal for draft amendments to Regulation No. 36
13.	Germany	2.	E	Proposal for draft amendments to Regulation No. 52
14.	Germany	3.	E	Proposal for draft amendments to Regulation No. 107
15.	Japan	9.	E	Accidents to children involving relatives or close associates – low-speed accidents caused by relatives or close associates – ITARDA Information 2001 No. 31
16.	Japan	9.	E	National Regulations concerning driver's field of vision of immediate frontward and sideward
17.	Japan	10.	E	Draft corrigendum to the document TRANS/WP.29/GRSG/2003/10 (Draft gtr on masses and dimensions)
18.	Germany	2.	E	Proposal for draft amendments to Regulation No. 52. Corrigendum to document TRANS/WP.29/GRSG/2002/6.
19.	OICA	3.	E	OICA proposal for a draft addendum to the proposal for draft 01 series of amendments to Regulation No. 107 (M2 and M3 vehicles) TRANS/WP.29/GRSG/2003/5
20.	OICA	11.4.	E	OICA proposal for a draft addendum to the proposal for draft Regulation on heating systems (TRANS/WP.29/GRSG/2002/11/Add.1)

<u>No</u>	<u>Transmitted by</u>	<u>Agenda item</u>	<u>Language</u>	<u>Title</u>
21.	European Community	10.	E	Proposal for draft amendment to document TRANS/WP.29/GRSG/2003/10 (draft gtr on common definitions and procedures to be used in global technical regulations
22.	Canada	11.1.	E	Draft global technical regulation No. XXX (Draft TRANS/WP.29/GRSG/2000/8/Rev.3)
23.	The Netherlands		E	Remarks to the OICA proposal to amend ECE- Regulation 107 on double deck vehicles (TRANS WP29/GRSG/2003/5)
24.	OICA	3.	E	Amendments to the proposal for draft revision 1 of Regulation No. 107
25.	Canada	10.	E	Draft TRANS/WP.29/GRSG/2003
26.	Japan	10.		Draft corrigendum to the document TRANS/WP.29/GRSG/2003/10
--	United Kingdom	3.	E	The safety of wheelchair occupants

Annex 2

AMENDMENTS TO REGULATION No. 52 ADOPTED
BY GRSG AT ITS EIGHTY-FOURTH SESSION
(see paragraph 6. of this report)

Paragraph 5.7.8.1.3.2., amend to read:

"5.7.8.1.3.2. Intrusion of a structural member provided that the intrusion is included within a triangle whose peak is situated 70 cm from the top and whose base is 10 cm in width and situated in the upper part of the space in question, adjacent to the side wall of the vehicle (see annex 3, figure 7)."

Annex 3, figure 7, amend to read:

"Figure 7

Permitted intrusion of a structural member

(see paragraph 5.7.8.1.3.2.)

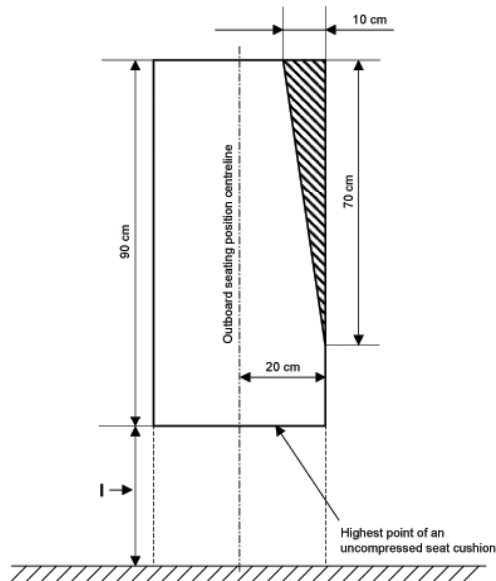

l (cm) min.
40-50
(35 cm at wheel arches and engine compartment)

"

Annex 3

AMENDMENTS TO DOCUMENT TRANS/WP.29/GRSG/2003/5
ADOPTED BY GRSG AT ITS EIGHTY-FOURTH SESSION
(see paragraph 10. of this report)

Paragraph 1.1., footnote 1/, the reference to "annex 8", correct to read "annex 7".

Paragraph 3.4., amend to read:

"3.4. Vehicle(s) or bodywork(s) representative of the type "

Paragraph 5.1., amend to read:

"5.1. All vehicles shall comply with the provisions set out in annex 3 to this Regulation (modified by annex 9 in the case of double-deck vehicles). Bodyworks approved separately shall comply with annex 5 and/or 10 as appropriate. The approval of a vehicle incorporating a bodywork approved in accordance with annex 10 shall be completed in accordance with that annex."

Paragraphs 6. to 6.1.1., amend to read:

"6. MODIFICATION OF A VEHICLE OR BODYWORK TYPE

6.1. Every modification of the vehicle or bodywork type which approved the type. That department

6.1.1. consider that case, the vehicle or bodywork still complies"

Paragraph 7.1., amend to read:

"7.1. Vehicles and bodyworks approved to this"

Paragraph 8.1., amend to read:

" of a vehicle or bodywork type pursuant"

Paragraph 9., amend to read:

""

" a type of vehicle or bodywork under this Regulation conforming to the model in annex 1, part 1 to this Regulation"

Annex 1, part 1, appendix 1,

Items 3.2.1. to 3.2.1.3., should be deleted.

Items 3.2.2. to 3.2.2.5., renumber as items 3.2.1. to 3.2.1.5.

Item 4.1., amend to read (footnote 1/ not amended):

"4.1. Type of bodywork: single deck / double deck / articulated / low floor 1/ "

Explanatory note (c), the reference to "annex 8" should read "annex 7".

Annex 1, part 1, appendix 2,

Item 4.1., amend to read (footnote 1/ not amended):

"4.1. Type of bodywork: single deck / double deck / articulated / low floor 1/ "

Annex 1, part 2, appendices 1, 2 and 3,

SECTION I, amend to read (footnotes 1/, 2/ and 3/ not amended):

"SECTION I

1. Make (trade name of manufacturer):
2. Type:
3. Means of identification of type if marked on the vehicle/ component/ separate technical unit 1/ 2/
- 3.1. Location of that marking:
4. Category of vehicle 1/ 3/
5. Name and address of manufacturer:
6. In the case of components and separate technical units, location and method of affixing of the type-approval mark:
7. Address(es) of assembly plant(s):"

Annex 1, part 2, appendix 1,

The addendum to the type approval certificate, correct the numeration of items 1.4. (second time) to 6. to read 1.7. to 2., and insert a new item 1.13., to read:

"1.13 Approval granted in accordance with annex 11, paragraph 7.6.3.1. (A) / paragraph 7.6.3.1. (B) 1/"

Annex 1, part 2, appendix 2, the addendum to the type-approval certificate,

Items 1.9. and 1.9.1., renumber as items 1.8. and 1.8.1.

Items 5. and 6., renumber as items 2. and 3.

Annex 1, part 2, appendix 3, the addendum to the type-approval certificate, renumber items 1.8. to 1.9.1. as items 1.3. to 1.4.1. and item 5. as item 2., and insert a new item 1.5., to read:

"1.5. Approval granted in accordance with annex 11, paragraph. 7.6.3.1. (A) / paragraph 7.6.3.1. (B) 1/"

Annex 11,

Paragraph 2.4., amend to read:

"2.4. "Vehicle dimensions" means the dimensions of the vehicle based on its construction, as stated by the manufacturer."

Insert new paragraphs 2.4.1. to 2.4.3., to read:

"2.4.1. "Vehicle length" is a dimension which is measured according to ISO standard 612-1978, term No 6.1.

In addition to the provisions of that standard, when measuring the vehicle length the following devices must not be taken into account:

- wiper and washer devices,
- front or rear marking-plates,
- customs sealing devices and their protection,
- devices for securing the tarpaulin and their protection,
- lighting equipment,
- mirrors and other devices for indirect vision,
- watching aids,
- air-intake pipes,
- length stops for demountable bodies,
- access steps and hand-holds,
- ram rubbers and similar equipment,
- lifting platforms, access ramps and similar equipment in running order, not exceeding 300 mm, provided that the loading capacity of the vehicle is not increased,

- coupling devices for motor vehicles,
- trolley booms of electrically-propelled vehicles,
- external sun visors.

2.4.2. "Vehicle width" is a dimension which is measured according to ISO standard 612-1978, term No. 6.2.

In addition to the provisions of that standard, when measuring the vehicle width the following devices must not be taken into account:

- customs sealing devices and their protection,
- devices for securing the tarpaulin and their protection,
- tyre failure tell-tale devices,
- protruding flexible parts of a spray-suppression,
- lighting equipment,
- access ramps in running order, lifting platforms and similar equipment in running order provided that they do not exceed 10 mm from the side of the vehicle and the corners of the ramps facing forwards or rearwards are rounded to a radius of not less than 5 mm; the edges must be rounded to a radius of not less than 2.5 mm,
- mirrors and other devices for indirect vision,
- tyre-pressure indicators,
- retractable steps,
- the deflected part of the tyre walls immediately above the point of contact with the ground,
- watching aids,
- retractable lateral guidance devices on buses and coaches intended for use on guided bus systems, if not retracted.

2.4.3. "Vehicle height" is a dimension which is measured according to ISO standards 612-1978, term No. 6.3.

In addition to the provisions of that standard, when measuring the vehicle height the following devices must not be taken into account:

- aerials,
- pantographs or trolley booms in their elevated position.

For vehicles with an axle-lift device, the effect of this device must be taken into account."

Paragraph 7.1., amend to read:

"7.1. Measurement of the mass of the vehicle in running order and of its distribution among the axles

The mass of..... measured on the vehicle(s) submitted in accordance with paragraph 3.4. of this Regulation placed in a stationary requirements below. Otherwise the measured masses must be used and the technical service may then, if necessary, carry out additional measurements on vehicle(s) other than those submitted in accordance with paragraph 3.4. of this Regulation."

Paragraph 7.1., correct the term "mj" to read "μj"

Paragraphs 7.5 to 7.5.2., amend to read:

"7.5. (Reserved)"

Paragraphs 7.6.3. and 7.6.4. (including its figures), amend to read:

"7.6.3. Additional requirements for vehicles of categories M2 or M3

There are two alternative methods of proving compliance with this paragraph – 7.6.3.1 (A) or 7.6.3.1 (B) below.

The United Kingdom and Portugal may, within their territory until 9 March 2005, refuse to grant national type-approval of a vehicle type, or refuse or prohibit the sale, registration, entry into service or use of a vehicle if the vehicle does not comply with the manoeuvrability criteria specified in paragraph 7.6.3.1. (B) below.

With the above exceptions, Contracting Parties shall grant approvals on the basis of paragraph 7.6.3.1. (A).

7.6.3.1. (A) With the vehicle stationary, a vertical plane tangential to the side of the vehicle and facing outwards from the circle shall be established by marking a line on the ground. In the case of an articulated vehicle, the two rigid portions shall be aligned with the plane. When the vehicle moves from a straight line approach into the circular area described in paragraph 7.6.1., no part of it shall move outside of that vertical plane by more than 0,60 m (see figures B and C).

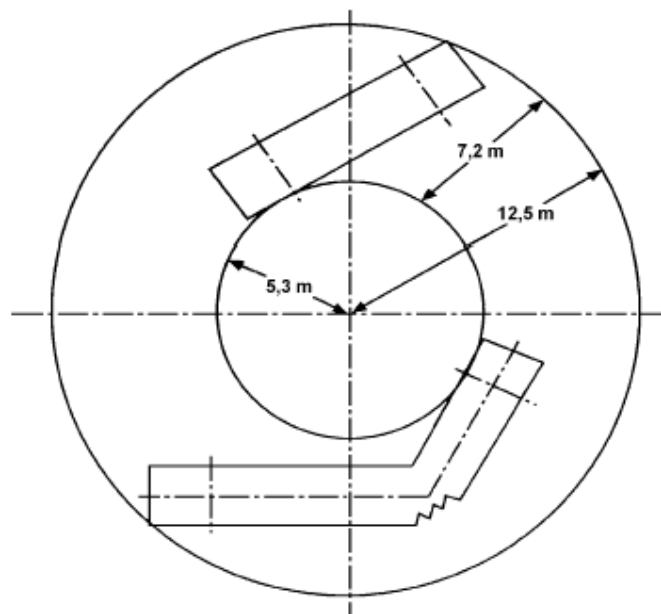

Figure A

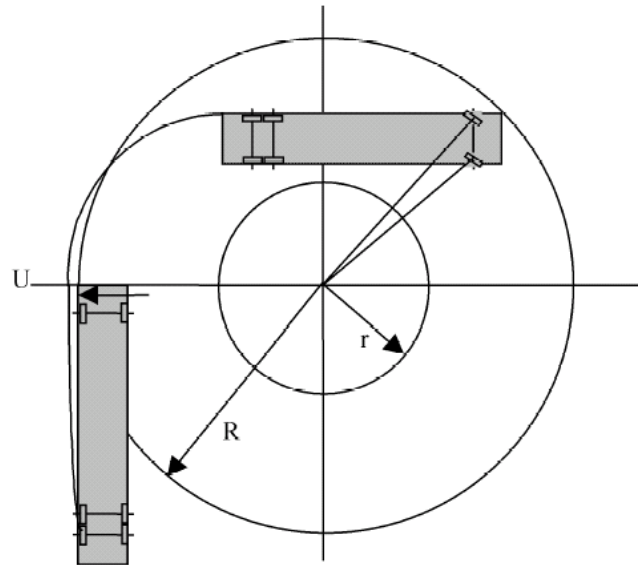

Figure B
 $R = 12.5$ m
 $r = 5.3$ m
 $U = \text{maximum } 0.6$ m

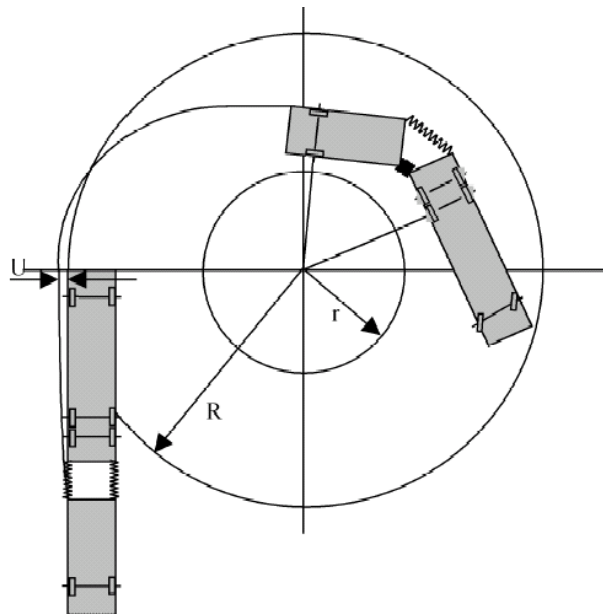

Figure C
 $R = 12.5$ m
 $r = 5.3$ m
 $U = \text{maximum } 0.6$ m

- 7.6.3.1. (B) When the vehicle is stationary and has its steered wheels so directed that if the vehicle moved, its outermost forward point would describe a circle of 12.50 m radius, a vertical plane tangential to the side of the vehicle which faces outwards from the circle must be established by marking a line on the ground. In the case of an articulated vehicle of category M2 or M3, the two rigid portions must be aligned with the plane.

When the vehicle moves forward on either side following the circle of 12.50 m radius, no part of it may move outside the vertical plane by more than 0.80 m (see Figure B) in the case of a rigid vehicle up to 12 m in length or by more than 1.20 m (see Figure C) in the case of a rigid vehicle of over 12 m in length or an articulated vehicle of category M2 or M3.

For vehicles with an axle-lift device this requirement also applies to the axle(s) in the lifted position (within the meaning of paragraph 2.14.).

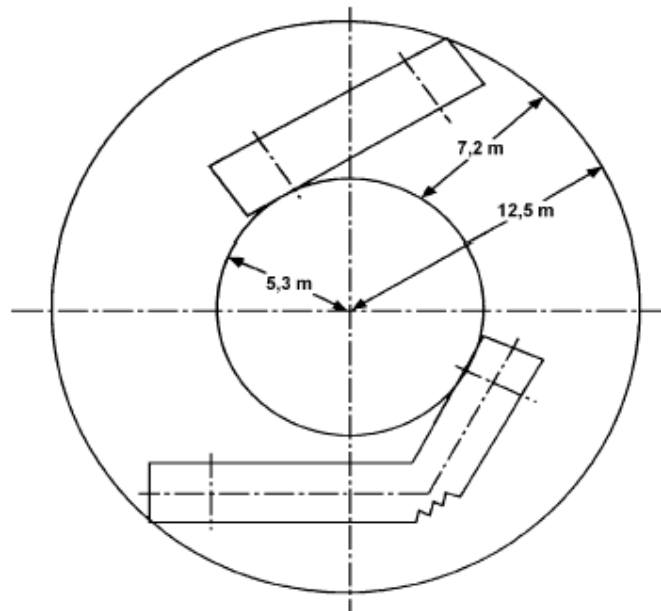

Figure A

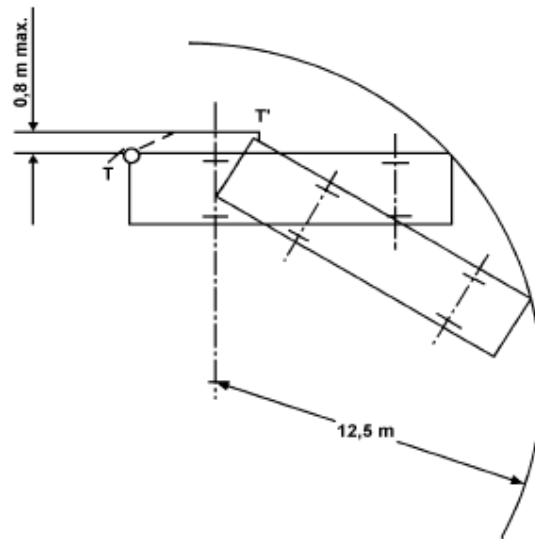

Figure B

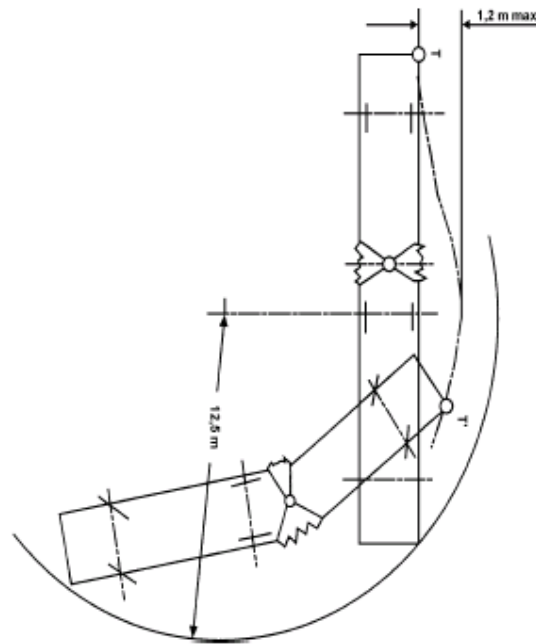

Figure C

7.6.4. The requirements of paragraphs 7.6.1. to 7.6.3. may also be verified, at the request of the manufacturer, with an appropriate equivalent calculation or geometric demonstration."
