

Source of flooding and location	#Depth in feet above ground. * Elevation in feet (NGVD) • Elevation in feet (NAVD)	Source of flooding and location	#Depth in feet above ground. * Elevation in feet (NGVD) • Elevation in feet (NAVD)
Approximately 0.45 mile upstream of Town of Fulton and Middleburgh corporate limits	•668	<p align="center">Town of Richmondville</p> <p>Maps available for inspection at the Richmondville Town Clerk's Office, 340 Main Street, Richmondville, New York.</p>	
<p>Town and Village of Esperance, Town of Fulton, Town and Village of Middleburgh, Town and Village of Schoharie</p> <p><i>School House Creek:</i> At confluence with Stoney Creek</p>	•638	<p align="center">Town of Schoharie</p> <p>Maps available for inspection at the Schoharie Town Office, 289 Main Street, Schoharie, New York.</p>	
Approximately 0.61 mile upstream of Straub Lane	•792	<p align="center">Village of Schoharie</p> <p>Maps available for inspection at the Schoharie Village Office, 256 Main Street, Schoharie, New York.</p>	
<p>Village and Town of Middleburgh</p> <p><i>Stoney Creek:</i> At confluence with Schoharie Creek</p>	•638	<p align="center">Town of Wright</p> <p>Maps available for inspection at the Wright Town Hall, 105 School Street, Suite 1, Gallupville, New York.</p>	
Approximately 1,620 feet upstream of U.S. Route 145	•758		
<p>Village and Town of Middleburgh</p> <p>Town of Cobleskill</p> <p>Maps available for inspection at the Cobleskill Town Office, 2668 State Route 7, Suite 37, Cobleskill, New York.</p>		(Catalog of Federal Domestic Assistance No. 83.100, "Flood Insurance")	
<p align="center">Village of Cobleskill</p> <p>Maps available for inspection at the Cobleskill Village Planning Department, 378 Mineral Springs Road, Suite 5, Cobleskill, New York.</p>		Dated: November 18, 2003.	
<p align="center">Town of Esperance</p> <p>Maps available for inspection at the Esperance Town Hall, 104 Charleston Street, Esperance, New York.</p>		Anthony S. Lowe,	
<p align="center">Village of Esperance</p> <p>Maps available for inspection at the Esperance Village Hall, Church Street, Esperance, New York.</p>		<i>Mitigation Division Director, Emergency Preparedness and Response Directorate.</i>	
<p align="center">Town of Fulton</p> <p>Maps available for inspection at the Fulton Town Office, 1168 Bear Ladder Road, West Fulton, New York.</p>		[FR Doc. 03-29796 Filed 11-28-03; 8:45 am]	
<p align="center">Town of Middleburgh</p> <p>Maps available for inspection at the Middleburgh Town Hall, 146 Railroad Avenue, Middleburgh, New York.</p>		BILLING CODE 6718-04-P	
<p align="center">Village of Middleburgh</p> <p>Maps available for inspection at the Middleburgh Village Municipal Building, 309 Main Street, Middleburgh, New York.</p>		DEPARTMENT OF TRANSPORTATION	
		National Highway Traffic Safety Administration	
		49 CFR Parts 571 and 586	
		[Docket No. NHTSA-03-16523]	
		RIN 2127-AF36	
		Federal Motor Vehicle Safety Standards; Fuel Systems Integrity	
		AGENCY: National Highway Traffic Safety Administration (NHTSA), Department of Transportation (DOT).	
		ACTION: Final rule.	
		SUMMARY: In this document, NHTSA is upgrading the rear impact test in the Federal motor vehicle safety standard on fuel system integrity. To simulate being struck in the rear by another vehicle, that standard currently specifies that the full width of the rear of the test vehicle be impacted with a flat, rigid barrier at speeds up to 48 km/h (30 mph). This final rule replaces that	

full rear impact test procedure with an offset rear impact test procedure specifying that only a portion of the width of the rear of the test vehicle be impacted at 80 km/h (50 mph). Under the new rear impact procedure, a lighter, deformable barrier is used. The barrier is very similar to the one used for dynamic testing in the agency's side impact protection standard, except that the rear impact barrier's face is mounted slightly lower to simulate the diving of the front end of a vehicle during pre-crash braking. The agency has concluded that the new, more stringent rear impact test procedure will save lives and prevent injuries.

This final rule replaces the standard's lateral (side) impact test procedure with the procedure specified in the agency's side impact protection standard at an impact speed range of 53 ± 1 km/h. The agency has concluded that this change will provide a more realistic test, increase safety, and reduce testing costs.

DATES: This final rule is effective January 30, 2004. Voluntary compliance is permitted on or after that date. If you wish to submit a petition for reconsideration of this rule, your petition must be received by January 15, 2004.

ADDRESSES: You may submit petitions for reconsideration [identified by DOT DMS Docket Number] by any of the following methods:

- Web Site: <http://dms.dot.gov>.
- Follow the instructions for submitting comments on the DOT electronic docket site.

- Fax: (202) 493-2251.
- Mail: Docket Management Facility; U.S. Department of Transportation, 400 Seventh Street, SW., Nassif Building, Room PL-401, Washington, DC 20590-001.

- *Hand Delivery:* Room PL-401 on the plaza level of the Nassif Building, 400 Seventh Street, SW., Washington, DC, between 9 a.m. and 5 p.m., Monday through Friday, except Federal Holidays.

- *Federal eRulemaking Portal:* Go to <http://www.regulations.gov>. Follow the online instructions for submitting comments.

Instructions: All submissions must include the agency name and docket number or Regulatory Identification Number (RIN) for this rulemaking. Note that all comments received will be posted without change to <http://dms.dot.gov>, including any personal information provided. Please see the Privacy Act heading under Regulatory Notices. *Docket:* For access to the docket to read background documents or comments received, go to <http://>

dms.dot.gov at any time or to Room PL-401 on the plaza level of the Nassif Building, 400 Seventh Street SW., Washington, DC, between 9 a.m. and 5 p.m., Monday through Friday, except Federal Holidays

FOR FURTHER INFORMATION CONTACT: For technical and other non-legal issues, you may call Dr. William J.J. Liu, Office of Crashworthiness Standards, Telephone: (202) 366-2264, Fax: (202)-366-4329.

For legal issues, you may call Mr. Chris Calamita, Office of Chief Counsel Telephone: (202) 366-2992, Fax: (202)-366-3820.

You may send mail to both of these officials at the National Highway Traffic Safety Administration, 400 Seventh Street SW., Washington, DC 20590.

You may call Docket Management at (202)-366-9324. You may visit the Docket on the plaza level at 400 Seventh Street SW., Washington, DC, from 10 a.m. to 5 p.m., Monday through Friday.

SUPPLEMENTARY INFORMATION:

Table of Contents

- I. Background
 - A. Existing Standard
 - B. Safety Problem
- II. 1995 Advance Notice of Proposed Rulemaking
- III. 2000 Notice of Proposed Rulemaking
 - A. Proposed Rear Impact Test Procedure
 - B. Proposed Side Impact Test Procedure
 - C. Door System Integrity
 - D. Lead Time
 - E. Costs and Benefits
 - F. Request for Comments on Additional Issues
- IV. Summary of Comments
 - A. Rear Impact Test Procedure Upgrade
 - B. Side Impact Test Procedure Upgrade
 - C. Door System Integrity
 - D. Lead Time
 - 1. Rear Impact Test Upgrade
 - 2. Side Impact Test Upgrade
 - E. Costs and Benefits
 - F. Additional Issues
 - 1. Real World Data
 - 2. Head and Neck Injury Criteria
 - 3. Seat Back Failure
 - 4. Use of 5th Percentile Female Dummies
 - 5. Test Vehicle Loading Conditions
 - 6. Lowering the Barrier Face
 - 7. Pole Side Impact Test
 - 8. Prohibiting Fuel Leakage in Frontal Impact Crash Tests
 - 9. Compliance Responsibility of Second-Stage Manufacturers
 - 10. Fuel Siphoning
- V. Final Rule
 - A. Summary of the Final Rule
 - B. Rear Impact Test Procedure
 - C. Side Impact Test Procedure
 - D. Door System Integrity
 - E. Lead Time
 - 1. Rear Impact Test Upgrade
 - 2. Side Impact Test Upgrade
 - F. Benefits
 - G. Costs
 - H. Additional Issues

- 1. Real World Data
 - 2. Head and Neck Injury Criteria
 - 3. Seat Back Failure
 - 4. Use of 5th Percentile Female Dummies
 - 5. Test Vehicle Loading Conditions
 - 6. Lowering the Barrier Face
 - 7. Pole Side Impact Test
 - 8. Prohibiting Fuel Leakage in Frontal Impact Crash Tests
 - 9. Compliance Responsibility of Second-Stage Manufacturers
 - 10. Fuel Siphoning
- VI. Rulemaking Analyses and Notices

I. Background

A. Existing Standard

Standard No. 301, *Fuel system integrity*, sets performance requirements for the fuel systems of vehicles with a gross vehicle weight rating (GVWR) of 4,536 kg (10,000 pounds) or less. The standard, which was issued in the 1970s, limits the amount of fuel spillage from fuel systems of vehicles during and after being subjected to a frontal, rear, or side impact test.

In the frontal impact test, the test vehicle is driven forward into a fixed barrier at 48 km/h (30 mph). In the rear impact test, a 1,814 kg (4,000 pound) barrier moving at 48 km/h (30 mph) is guided into the full width of the rear of a stationary test vehicle. In the side impact test, a 1,814 kg (4,000 pound) barrier moving at 32 km/h (20 mph) is guided into the side of a stationary test vehicle. The standard sets three separate limits on fuel spillage from crash-tested vehicles: 28 grams (1 ounce) by weight, during the time period beginning with the start of the impact and ending with the cessation of vehicle motion; a total of 142 grams (5 ounces) by weight during the 5-minute time period beginning with the cessation of vehicle motion; and 28 grams (1 ounce) by weight during any 1-minute interval in the 25-minute period beginning with the end of the 5-minute period.

Similar fuel spillage limits apply to vehicles tested in accordance with the standard's static rollover test procedure.¹ The rollover test is conducted after frontal, rear, and side impact tests.

B. Safety Problem

Preserving fuel system integrity in a crash is critical to preventing occupant exposure to fire. Although vehicle fires are relatively rare events (occurring in

less than 1 percent of vehicles in towaway crashes), they tend to be severe in terms of the number of casualties caused. According to an analysis of data in the agency's Fatality Analysis Reporting System (FARS) in 2001, 3.5 percent (1,449 fatalities) of light vehicle occupant fatalities occurred in crashes involving fire.² Overall, the fire itself was deemed to be the most harmful event in the vehicle for about 24 percent (341) of these fatalities.

An analysis of 1993-2001 National Automotive Sampling System (NASS) data indicated that each year an average of about 15,820 occupants were exposed to a post-crash fire in passenger cars and light vehicles (vans, pickup trucks, and multipurpose passenger vehicles) with a GVWR of 4,536 kg (10,000 pounds) or less that were towed away after the fire. Of those occupants, about 736 (6 percent) received moderate or severe burns (AIS 2 and greater). Three-quarters of those with moderate and more severe burns had second or third degree burns over more than 90 percent of the body. Moreover, the agency notes that maximum-severity (AIS 6) burns are nearly always fatal. These statistics underscore the importance of preserving fuel system integrity in a crash in order to prevent vehicle fires.

II. 1995 Advance Notice of Proposed Rulemaking

On April 12, 1995, NHTSA published an Advance Notice of Proposed Rulemaking (ANPRM) announcing the agency's plans to consider upgrading Standard No. 301.³ The agency explained that it was considering using a three-phase approach to upgrade the requirements of the standard. Phase 1 would focus on requirements for component performance (e.g., fuel tanks, fuel pumps, and electrical systems); Phase 2 would address system performance (e.g., shutting down fuel supply and potential ignition sources in the event of a breach in the fuel system); and Phase 3 would address issues related to environmental and aging effects (e.g., the potential relationship of vehicle aging to fire occurrence). The

² These fatalities included fatalities due to burns and/or impact injuries, but not due to asphyxiation.

³ 60 FR 18566. Previously, the agency published a Request for Comments notice stating that NHTSA was "considering initiating rulemaking to upgrade the protection currently provided by" Standard No. 301. 57 FR 59041, December 14, 1992; Docket No. 92-66, Notice 1. The notice also requested answers to specific questions related to test impact speeds, impact barriers, effect of vehicle aging on the likelihood of fire, contribution of occupant entrapment to the likelihood of fire-related injuries, etc.

¹ Under S5.6, *Fuel spillage; rollover*, when a vehicle is rotated along its longitudinal axis to each successive increment of 90 degrees, fuel spillage from the onset of rotational motion must not exceed 142 grams (5 ounces) for the first 5 minutes of testing, at each successive 90 degree increment. For the remaining test period at each increment of 90 degrees, fuel spillage during any one minute interval must not exceed 28 g (1 ounce).

agency sought comment on this approach as well as several other issues.

NHTSA received comments from component and vehicle manufacturers, industry associations, consumer advocacy organizations, and other organizations. After reviewing these comments and further analysis, the agency made the following decisions.

First, after examining the effectiveness of fuel pump shut-off devices in reducing post-crash vehicle fires, the agency decided not to pursue rulemaking with respect to fuel system component performance. The agency's review of NASS data did not reveal a significant difference in the rate or severity of post-crash fire occurrence in vehicles with and without fuel pump shut-off devices. Research conducted under the General Motors (GM) C/K settlement agreement⁴ confirmed this finding during crash testing with and without fuel pump shut-off devices. During crash testing, there was no difference in the rate of fuel leakage or severity of post-crash fire occurrence between vehicles equipped with shut-off switches (Ford) and those without (GM, Chrysler and Honda).

Second, the agency decided not to pursue rulemaking related to environmental and aging effects. The agency agreed with vehicle manufacturer comments that further studies were needed to define the problems associated with environmental and aging effects and determine whether rulemaking would be appropriate to address them. The agency stated that it might revisit this issue upon further study. As part of the GM settlement, GM contracted with Southwest Research Institute to conduct research on the environmental factors and aging effects on fuel system components. This report showed some effects of corrosion on metal components and some effects of hot arid conditions on rubber components, and little effect on plastic components. The findings were inconclusive, but did not indicate serious problems affecting fuel system crash performance. No further agency action is planned at this time.⁵

⁴ On December 2, 1994, the Secretary of Transportation announced a settlement of an investigation by NHTSA of an alleged safety defect in certain GM pickup trucks with fuel tanks mounted outside the frame rails. Under that settlement, GM contributed over \$51.3 million for a variety of safety initiatives. Among other things, the settlement funded research on ways to reduce the occurrence and effects of post-crash fires. All relevant results of this research are being placed in dockets NHTSA-98-3585, NHTSA-98-3588, Docket No. 96-GMRSCH-GR, and Docket No. 95-20-GR.

⁵ <http://dms.dot.gov/search/document.cfm?documentid>

Third, the agency decided to investigate the feasibility and practicability of upgrading Standard No. 301's rear and side impact requirements. The agency reviewed real world crash data to determine what types of rear impact crashes resulted in "moderate," "severe," and "very severe" fires.⁶ Next, the agency analyzed the data to determine whether it was the fire or the impact of the crash that caused the fatalities and injuries in the fire-related crashes. NHTSA then examined the data to determine the characteristics of rear crashes that were causing fire-related fatalities and injuries and developed a new crash test procedure to simulate the most frequent crash scenario that leads to fire and fire-related fatalities and injuries in rear impact crashes. The agency then performed seventeen crash tests using the new crash test procedure.⁷

III. 2000 Notice of Proposed Rulemaking

A. Proposed Rear Impact Test Procedure

After reviewing the comments on the 1995 ANPRM and analyzing the real world crash data and data from the seventeen crash tests with the new crash test procedure, the agency published a Notice of Proposed Rulemaking (NPRM) on November 13, 2000.⁸ In the NPRM, the agency tentatively concluded that the proposed rear impact test procedure would reduce fire-related fatalities and injuries from rear impact crashes. Thus, the agency proposed to replace Standard No. 301's current rear impact test procedure with one that would specify impacting the rear of the test vehicle at 80 ± 1 km/h (50 mph) with a 1,368 kg (3,015 pound) moving deformable barrier (MDB) at a 70 percent overlap with the test vehicle. That barrier is very similar to that used under Standard No.

=183754&docketid=3588 Docket Number NHTSA-1988-3588-177 (Miller, Michael et al. "First, Second and Third Progress Reports and Final Report—Inspection of Aging Vehicles and Testing Components")

⁶ A "moderate" fire is defined as fire damage to between 25 and 50 percent of the vehicle surface; a "severe" fire is fire damage to between 50 and 75 percent of the vehicle surface; and a "very severe" fire is fire damage to more than 75 percent of the vehicle surface.

⁷ The rear impact tests used a 1,368 kg (3,015 pound) moving deformable barrier (MDB) with the barrier lowered by 50 mm (2 inches) to simulate pre-crash braking. The MDB impacted the test vehicle at 80 km/h (50 mph) parallel to the longitudinal centerline of the test vehicle with a 70 percent overlap on the side of the vehicle where the fuel filler neck was located. However, the new rear impact test allows the MDB to strike the rear with the overlap on either side of the vehicle for all possible worst case scenarios, including dual fuel tank designs with filler necks on both sides and filler neck in the center of the rear.

⁸ 65 FR 67693, Docket No. NHTSA-2000-8248.

214, *Side impact protection*, in dynamic side impact testing except that the face of the MDB used in rear impact testing under Standard No. 301 would be 50 mm (2 inches) lower than the face of the Standard No. 214 barrier to simulate pre-crash braking.⁹

The agency noted that the proposed test procedure would simulate a type of rear vehicle-to-vehicle collision that can result in post-crash fire in an otherwise survivable crash: a high speed offset rear strike to the vehicle that results in fuel leakage from a breach in the fuel system and, potentially, a rapidly spreading fire that results in fatalities and injuries. The agency also noted that NASS estimates show that the majority of fatal and nonfatal occupant burn injuries in rear impact crashes occurred in crashes in the 34 to 48 km/h (21 to 30 mph) delta-v range. The agency stated that the elements of the proposed offset rear impact test procedure were accordingly chosen to simulate vehicle-to-vehicle crashes with a delta-v range of 32 to 48 km/h (20 to 30 mph).

The agency tentatively concluded that the proposed offset rear impact test procedure was practicable. The agency stated:

Crash test results indicate that large, medium, and small vehicles could be designed to meet the standard under the proposed upgraded rear impact procedure. In those tests, some small as well as large existing light-duty vehicles already meet the proposed upgrade. Several larger light-duty vehicles, including passenger cars, multipurpose passenger vehicles, and light trucks, all passed the proposed upgrade. In addition, several small vehicles, the Mazda Miata, Chevrolet Metro, Nissan Sentra, and Honda Civic, passed the proposed upgrade. While we are aware that some existing smaller vehicles leaked fuel when tested under the proposed upgraded test procedure (e.g., the 1996 Suzuki Sidekick, Dodge Neon, and Geo Prizm, and the 1998 Chevrolet Cavalier, VW Jetta, and Ford Escort), we believe that relatively minor, inexpensive design changes would correct the vast majority of the failures.¹⁰ For example, the fuel lines in the Dodge Neon could be rerouted, and the area on top of the tank around the fuel sender unit plastic sealing plate could be reinforced on the VW Jetta.¹¹

NHTSA did not propose to require manufacturers to place each vehicle's

⁹ Standard No. 214, Side Impact Protection, specifies that the bottom of the face of the barrier is 11 inches above the ground and the bottom of the bumper is 13 inches above the ground. See Figure 2.

¹⁰ The Ford Mustang test series demonstrated the technical feasibility of redesigning a 1993 Ford Mustang so that it would pass the proposed upgrade test procedure (the 1996 Ford Mustang test). It demonstrated that structural and component design are critical, regardless of the fuel tank location, for passing the upgrade.

¹¹ 65 FR at 67701.

fuel tank forward of the rear axle, as suggested by Advocates for Highway and Auto Safety (Advocates) in its comment on the ANPRM, because the agency believed such a requirement would be unnecessary and too design restrictive. The agency noted that the fuel tank of the 1996 Ford Mustang, which passed the proposed upgraded test procedure, is located behind the rear axle. The agency stated that this test demonstrated that structural and component designs are more critical factors than fuel tank location in maintaining fuel system integrity.

NHTSA also did not propose to use a heavier barrier (*e.g.*, a 4,000-pound barrier) to simulate impacts by light trucks and sport utility vehicles, again as suggested by Advocates, because in an 80 km/h (50 mph) rear impact offset crash test, a 3,015-pound barrier effectively reproduces the damage profile seen in real world crashes that most often lead to fires. The agency stated that if a heavier barrier were used, the proposed rear impact crash test would no longer reproduce that profile. The agency also noted that it had conducted its research crash tests with a 3,015-pound barrier, and that further research and development would have to be conducted before a heavier barrier could be proposed for use in any test procedure.

B. Proposed Side Impact Test Procedure

NHTSA proposed to replace the current lateral (side) impact crash test in Standard No. 301 with the side impact crash test currently specified in Standard No. 214. The Standard No. 214 side impact crash test specifies that a stationary vehicle be struck on either side by a 1,368 kg (3,015 pound) MDB moving at a speed of 54 km/h.¹²

The agency reasoned that test analyses show that the Standard No. 214 side impact crash test exposes a tested vehicle to higher crush energy and crash forces, and to greater changes in velocity, than the existing Standard No. 301 side test. Test data also show the Standard No. 214 test exposes the fuel system components to greater forces.

Moreover, the agency reasoned that replacing the Standard No. 301 side test

with the Standard No. 214 side impact test would reduce certification testing costs for manufacturers because they would only have to conduct one type of side impact test instead of two. The agency also noted that commenters on the ANPRM supported this change, stating that the change would be beneficial from both a safety and a cost perspective.

C. Door System Integrity

In the NPRM, the agency also stated that it was considering adding a post-crash door openability test requirement to Standard No. 206.¹³ NHTSA noted that NASS data indicate that potential escape from a post-crash vehicle fire was made more difficult for occupants with moderate or more serious burns because, among other reasons, they were sitting next to a door that was jammed shut by crash forces. The agency also noted that real-world crash reports indicate that there were instances in which fire suddenly started several minutes after the vehicle was impacted. Thus, the agency concluded that it is critical that occupants be able to exit the vehicle quickly and easily after a crash that could lead to a fire. The agency requested comment on whether such a requirement was necessary and, if so, what type of requirements would be appropriate, objective, and repeatable.

D. Lead Time

NHTSA proposed a lead time of three years for the proposed upgraded rear impact test and one year for the change to the Standard No. 214 side impact test. The agency stated that a three-year lead time appeared to be necessary for the proposed upgraded rear impact test because: (1) All of a manufacturer's makes and models would have to be tested under the upgraded test to determine compliance; and (2) for those vehicles that did not comply, countermeasures would have to be incorporated into designs and then implemented in engineering and manufacturing. The agency stated that only one year of lead time was needed for the new side impact test because few, if any, design changes would be necessary.

NHTSA stated that between the date the final rule was issued and the date it took effect, manufacturers would be allowed the option of certifying vehicles under the existing Standard No. 301 tests or under the new tests. However, manufacturers would have to irrevocably select a test when they certified the vehicle.

¹³ Standard No. 206 specifies requirements for door locks and door retention components.

E. Costs and Benefits

The agency prepared a Preliminary Regulatory Evaluation (PRE) describing the costs and benefits of the proposed upgraded test procedures.¹⁴ NHTSA estimated that the average cost for vehicles that need to be modified to comply with Standard No. 301's requirements under the proposed test procedures would be \$5 per vehicle. The agency also estimated that 46 percent of the vehicle fleet would have to be so modified.¹⁵ Since approximately 15.2 million vehicles are sold in the United States each year, the agency estimated that the total cost of the proposed rule would be \$35 million each year.

NHTSA estimated that the proposed rule would save from 8 to 21 lives annually, once all vehicles on the road meet Standard No. 301's requirements under the proposed upgraded test procedures.

F. Request for Comments on Additional Issues

In the NPRM, the agency also requested comments on several issues. The questions are repeated below.

1. Are there any real-world data, other than the data that the agency has already analyzed for this proposed upgrade, that may better describe the relationship between the risk of occupant injury due to fire and crash severity?

2. Vehicle manufacturers. How many of your vehicle models would need some redesign to comply with the proposed offset rear impact and side impact test procedures? Describe the type and extent of design changes. What costs would be associated with those redesigns? Would you have any significant problems completing necessary redesigns within the three-year lead time? If so, please identify those problems and indicate how much lead time you would need.

3. What impact would the proposed changes have on vehicle safety?

4. Are the proposals sufficient and appropriate for the different sizes and types of vehicles?

5. In the various crash tests that were performed during the research for this rulemaking, the values of head and neck injury criteria measured by the responses of the two front Hybrid III anthropomorphic test devices were

¹⁴ A copy of the PRE was placed in the docket. See Docket No. NHTSA-2000-8248, entry 2.

¹⁵ A NHTSA-sponsored cost study indicated that none of the proposed remedies for the noncompliant vehicles will require major structural redesign that will change the vehicle's structural stiffness (NHTSA Docket No. NHTSA-008248-4, Nov. 16, 2000).

¹² Currently, Standard No. 214 specifies an impact speed of 54 km/h. In the NPRM, the agency proposed to change that specification in Standard No. 214 to 53 ± 1 km/h and adopt it for Standard No. 301. The agency noted that the new specification was very close to the speed (52.9 ± 0.8 km/h) at which NHTSA's Office of Vehicle Safety Compliance was conducting Standard No. 214 tests. As explained later, we are adopting this proposal. In addition, we are also adopting the proposal to delete several paragraphs of outdated requirements in Standard No. 214 that related solely to vehicles manufactured in the mid-1990s.

much higher than acceptable thresholds. Direct contact of the head of the dummy with the interior of the vehicle compartment, which occurred when the front seat rotated backward excessively due to the rear impact, contributed to these high values. These high values raise concerns about head and neck protection of the occupants. The rear impact testing also raised concerns about the seat back strength, as most seat backs collapsed in those tests. What do the high HIC values and neck loadings registered by the test dummies in those tests indicate about the real world potential for trauma injury to vehicle occupants in rear impacts? Could future vehicles be designed to provide both the improved fuel system integrity necessary to meet the more stringent requirements proposed in this NPRM and, at the same time, provide improved occupant protection in such impacts?

6. How do seat back failures influence the injury potential in rear impacts? Please provide data and other information that would aid the agency in determining the need for improving seat back strength and the appropriate requirements for doing so.

7. Should the agency require vehicles to retain fuel system integrity in tests with 5th percentile female dummies, as well as with 50th percentile male dummies, as is currently required?

8. NHTSA is proposing to eliminate the second sentence in S7.1.6(b) from Standard No. 301. That sentence reads: "If the weight on any axle, when the vehicle is loaded to unloaded vehicle weight plus dummy weight, exceeds the axle's proportional share of the test weight, the remaining weight shall be placed so that the weight on that axle remains the same." Given the specifications in S7.1.6(a) concerning the placement of rated cargo and luggage capacity weight in the luggage area and the placement of dummies, is the second sentence in S7.1.6(b) needed for conducting Standard No. 301 compliance tests?

9. For the rear offset MDB test conditions, the agency is proposing that the barrier be the same as the one shown in Figure 2 of Standard No. 214 and specified in 49 CFR Part 587, with one exception. The exception is that the face of the barrier would be positioned in the rear impact test so that it is 50 mm (2 inches) lower than the barrier face height specified in the current Figure 2 of Standard No. 214.¹⁶

¹⁶ The question also noted that positioning the barrier face in that manner might make it necessary to slightly change the center of gravity and moment of inertia specifications. NHTSA's subsequent

10. With respect to side impact crashes that result in fire, this proposal to upgrade Standard No. 301 addresses vehicle-to-vehicle crashes. There are approximately two to eight times as many side collision fires (depending on vehicle type) when the object struck is another vehicle compared to a narrow object such as a pole. However, the side collision fire rate for cars, light trucks, and vans is highest when a narrow object is struck. Would it therefore be reasonable to consider a pole side impact test as part of a subsequent upgrading of Standard No. 301?

11. Should the agency amend Standard No. 301 to prohibit fuel leakage in any crash test under Standard No. 208?

IV. Summary of Comments

NHTSA received comments to the NPRM from seven vehicle manufacturers (Subaru, DaimlerChrysler, Porsche, Volkswagen, Ford, Honda, and General Motors), two vehicle manufacturer associations (Alliance of Automobile Manufacturers¹⁷ and National Truck Equipment Association), three engineering firms (American Automotive Design, Dynamic Safety, and Syson-Hille and Associates), a test laboratory (Transportation Research Center), the Insurance Institute for Highway Safety, and a consumer advocate group, Advocates for Highway and Auto Safety. Their comments are summarized below by issue.

A. Rear Impact Test Procedure Upgrade

None of the commenters opposed the proposed rear impact test procedure upgrade.

The Alliance suggested that significant vehicle redesign will likely be required to meet the high speed rear crash requirements. Volkswagen (VW) stated that the rear end structure of small cars will need to be made stiffer, which could result in increased acceleration imposed on occupants in more common lower speed rear crashes. Honda commented that increased vehicle body and fuel tank deformation would occur, even on vehicles that pass the fuel leak requirements.

DaimlerChrysler (DC) stated its belief "that the proposal is likely to require significant changes to vehicle structure

analysis indicated that there will be no measurable effect on the center of gravity and the moment of inertia of the MDB by lowering the face of the barrier two inches (NHTSA Docket No. NHTSA-008248-3, November 16, 2000).

¹⁷ The members of the Alliance of Automobile Manufacturers are: BMW Group, DaimlerChrysler, Fiat, Ford Motor Company, General Motors, Isuzu, Mazda, Mitsubishi Motors, Nissan, Porsche, Toyota, Volkswagen, and Volvo.

and design, which are yet to be fully defined and realized." DC argued that the proposed upgrade is a "major rulemaking effort which will present many challenges to the industry that may not yet be fully identified."

DC also expressed concerns with using a MDB at the proposed impact speed (80 km/h). DC stated that in impacts between a MDB and a vehicle at 80 km/h, DC has observed complete crushing of the barrier face and ensuing contact with the rigid cart backer plate and contact between the cart uprights and the impacted vehicle. DC recommended that NHTSA reevaluate the proposed test procedure upgrade to determine if the anticipated benefits could be achieved with a lower impact speed (such as 56-64 km/h), or provide design changes to the MDB and cart system.

GM and Ford observed bottoming of the barrier face to the backing plate and contact between the barrier uprights and the vehicle in some rear impact crash tests. GM also stated that the barrier face can underide the struck vehicle and, upon rebound, the upright that contacted the vehicle can become "caught" on vehicle structure (e.g., bumper, frame cross member, etc.), with undetermined effects on the struck vehicle. GM and Ford suggested that some changes to the MDB might be necessary. Ford recommended that the agency investigate "rounding the corners of the deformable portion of the barrier and increasing its depth." Ford stated that its testing indicated that the right angle corners of the barrier face can "hang up on trim," potentially affecting test repeatability.

Honda commented that it had conducted rear impact crash tests in accordance with the proposed test procedure. Honda noted that the MDB sometimes over-rode the rear of the test vehicle, and that in these instances, the rear frame structure of the vehicle could not absorb crash energy sufficiently to meet the fuel leaking requirements of Standard No. 301. Honda also noted, "Even in instances when the rear frame functioned somewhat to absorb energy, the increased speed and the off-set impact caused extensive deformation of the fuel tank." Honda stated that a vehicle in compliance with the proposed upgrade would have to absorb twice as much energy as a vehicle in compliance with Standard No. 301 as currently written. Honda argued that under the proposed upgrade, significant changes would have to be made to each of its vehicle models.

VW noted that the proposed rear impact would be to either side of the vehicle. VW recommended that this be

changed so that the impact is on the side of the vehicle where the fuel filler pipe or filler neck is located. VW argued that impacting the side of the vehicle where the fuel filler pipe or filler neck is located would represent the worst case condition and establish a more objective requirement for enforcement purposes.

VW also commented that in order to assure compliance with the higher speed rear impact test, the vehicle rear end structure would have to be made stiffer, particularly in smaller cars. VW stated that this would tend to increase the potential for whiplash type injuries in lower speed crashes. VW recommended that NHTSA address this issue before issuing a final rule.

Ford commented that it has conducted voluntary, in-house 80 km/h vehicle-to-vehicle rear impact crash tests to evaluate fuel system integrity since the mid-1980s. Ford supported the agency's proposed test upgrade, stating, "Ford believes this test can provide a robust evaluation of a fuel system's integrity."

Syson-Hille commented that other vehicle manufacturers, such as GM, began conducting 80 km/h vehicle-to-vehicle rear impact crash tests in the 1980s, and that Mercedes-Benz marketing materials note that its vehicles have been designed to provide fuel system integrity in offset rear impact crashes since the early 1980s.

The Insurance Institute for Highway Safety (IIHS), Advocates for Highway and Auto Safety (Advocates), and American Automotive Design (AAD), urged NHTSA to require the use of a 4,000-pound rigid barrier, instead of the 3,015-pound MDB. IIHS and Advocates urged this based on their view that the Standard No. 214 barrier does not reflect the characteristics of pickup trucks and sport utility vehicles (SUV) and thus may not reproduce the patterns or extent of deformation seen when those types of vehicles strike cars in the side or rear.

B. Side Impact Test Procedure Upgrade

None of the commenters opposed the proposed side impact test procedure upgrade.

DC recommended that, as in the proposed rear impact test procedure, the agency specify that the MDB be lowered 50 mm (2 inches) in the proposed side impact test procedure. DC stated that data indicate that pre-impact braking occurs in 54 percent of side impacts.

C. Door System Integrity

Vehicle manufacturers generally opposed adding a post-crash test door operability requirement to Standard No.

206. The Alliance and GM agreed with and supported the logic regarding a post-crash test door operability requirement. However, the Alliance and GM stated that Standard No. 206 addresses component level performance, while a post-crash test door operability requirement would address vehicle level performance. The Alliance stated that adding such a requirement to Standard No. 206 would necessitate the addition of vehicle crash test requirements to the standard as well. The Alliance also stated,

Prior to proposing such requirements in future rulemakings, NHTSA would need to develop and define an objective set of meaningful and measurable requirements pertaining to the applicability of doors (front rear, sliding, etc.), number of doors (per row, per vehicle, etc.), and methodology by which operability would be assessed (without the use of tools is an insufficient measure, as NHTSA has concluded in past rulemaking efforts).

GM stated that such a requirement would be more appropriate if it were added to crash tests that are already required for other safety standards, such as Standard No. 208, *Occupant crash protection*, Standard No. 214, *Side impact protection*, or Standard No. 301. GM noted that it currently performs door operability evaluations following most barrier tests.¹⁸ GM argued that NHTSA should develop meaningful, appropriate, objective, and repeatable requirements for post-crash test door operability after further research and through separate rulemaking.

DC argued that NHTSA has not provided sufficient evidence to demonstrate the need for adding a post-crash test door operability requirement to Standard No. 206. DC recommended that NHTSA conduct research to determine such a requirement's real world benefits, feasibility, and effects on vehicle design, cost, and weight. DC suggested that if NHTSA persists in such a rulemaking, the agency require only one operable door per vehicle.

Advocates supported adding a post-crash test door operability requirement to Standard No. 206. Advocates stated:

Advocates believes that ensuring that doors can be opened after crashes is not a safety problem involving only fire-related collisions. It is a major safety issue long overdue for agency regulatory attention. Many thousands of crashes every year result in vehicle deformation preventing door opening. In these crashes, numerous people

are seriously injured whose lives could be saved or the severity of their injuries substantially reduced if rescue squads could quickly reach them without recourse either to the use of Jaws of Life or to being forced to extricate a seriously injured person through a window or windshield, a common practice.

Syson-Hille also supported a post-crash test door operability requirement. Syson-Hille recommended that the agency require at least one door on two-door vehicles and three doors on four-door vehicles to be operable after a crash test.

D. Lead Time

1. Rear Impact Test Upgrade

The vehicle manufacturers all supported the three-year lead time proposed in the NPRM for the rear impact test upgrade, but recommended that the agency add a phase-in after that period. The Alliance recommended a four-year phase-in with an implementation schedule of 25 percent compliance the first year, 40 percent the second year, 70 percent the third year, and 100 percent the fourth year. The Alliance also recommended that the agency grant carry forward credits for early compliance.

The Alliance argued that a phase-in is necessary because the Alliance considered this to be a "major rulemaking, particularly in response to the substantially increased impact energy of the high speed rear offset impact testing proposed." The Alliance stated:

Significant vehicle redesign and retooling for production will likely be required in a number of vehicles. The small number of tests conducted by the NHTSA, often with a sample size of one vehicle, simply is inadequate to identify whether vehicle changes are required or for any manufacturer to assure compliance for all its vehicles.

DC supported the Alliance's recommended phase-in schedule. DC argued that such a phase-in would "allow the efficient phasing out of older models designed to the current requirements with replacements that are thoroughly designed, constructed and tested to meet the more stringent requirements without very costly and disruptive mid cycle manufacturing changes."

Subaru recommended a three-year full phase-in, with complete compliance after the third year. Honda suggested a four-year phase-in with an implementation schedule of 10 percent, 30 percent, 70 percent, and 100 percent. Porsche supported the Alliance's recommended lead time but requested that the agency provide small volume manufacturers the option of coming into compliance at the 100 percent level in

¹⁸ GM stated, "These evaluations start by first actuating the door latch. Assuming the door unlatches a nominal force of approximately 100 pounds is applied to open the door using a hook-type dial gage. A measurement of how far the door could be opened is made and recorded."

the third year of the phase-in with no requirements in the first two years.

IIHS stated that the proposed three-year lead time for the rear impact test upgrade should be sufficient.

2. Side Impact Test Upgrade

Vehicle manufacturers supported the one-year lead time proposed in the NPRM for the side impact test upgrade, but recommended that the agency add a phase-in after this lead time. The Alliance and Ford recommended a four-year phase-in with an implementation schedule of 25 percent compliance the first year, 40 percent the second year, 70 percent the third year, and 100 percent the fourth year. The Alliance also recommended that the agency grant carry forward credits for early compliance.

IIHS stated that the one-year lead time proposed by the agency in the NPRM should be sufficient.

E. Costs and Benefits

Honda commented that the agency's cost estimates were insufficient. Honda stated, "The cost of managing all the accompanying issues is at least 10 times greater than NHTSA's cost estimation." Honda claimed that to meet the proposed rear impact test upgrade, "It will be necessary to change the thickness of the vehicle's rear structure, which requires the modification of existing dies and manufacturing of new dies and parts."

VW questioned the safety benefits of the proposed test upgrades. VW stated:

The accident data base of the Medical University of Hanover in Germany indicates that in the universe of crashes with at least one injured occupant, only 0.58 percent resulted in after-crash fire and only 0.4 percent of the injuries in the data base were fire related. In the same sample of crashes, the whiplash injuries were reported in 11 percent of the cases. Although the vehicle fleet population in Germany is different from that in the U.S., Volkswagen submits that the statistics support the very low incidence of post-crash fires and fire related injuries.

F. Additional Issues

1. Real World Data

The agency asked in the NPRM whether there were any real-world data, other than the data that NHTSA had already analyzed, that may better describe the relationship between the risk of occupant injury due to fire and crash severity.

The Alliance, GM, DC, and Ford stated that there were no such data. The Alliance and GM commented that both the FARS and NASS files might need to be modified to more accurately define any remaining fire risk.

2. Head and Neck Injury Criteria

In the NPRM, the agency noted that in the various crash tests that were performed during the research for this rulemaking, the values of head and neck injury criteria measured by the two front seat dummies were much higher than acceptable thresholds. The agency asked what these high injury values indicate about the real world potential for trauma injury to vehicle occupants in rear impacts.

The Alliance stated that its members would need access to more details of NHTSA's test program in order to respond to this question.¹⁹ However, the Alliance argued that the issue of occupant protection in rear impacts is outside the scope of this rulemaking. The Alliance recommended that the agency address this issue in the ongoing Standard No. 202, *Head restraints*, rulemaking or in a possible future upgrade of Standard No. 207, *Seating systems*. The Alliance also commented that more research is needed to provide an appropriate level of seating system performance dealing with the proposed rear impact test upgrade.

Syson-Hille commented that both GM and Mercedes-Benz have been using 50 mph vehicle-to-vehicle rear impact tests, with occupant survival space criteria, since the 1980s. Advocates suggested that the agency consider upgrading requirements for the entire seating system (seat, seat back, and head restraint) to provide improved occupant protection in the proposed Standard No. 301 rear impact test upgrade.

3. Seat Back Failure

In the NPRM, the agency asked how seat back failures influence injury potential in rear impacts. The agency also asked for data that would aid it in determining the need for improving seat back strength and the appropriate requirements for doing so.

The Alliance stated that without a definition of "seat back failure" it could not answer the question. However, the Alliance defined the optimal seat back strength as the balance between strength and flexibility to address both severe and minor impacts.

DC and Ford supported the Alliance's comments. DC commented that the issue of seat back strength is outside the scope of this rulemaking, and should be addressed in a possible future upgrade of Standard No. 207. Ford stated that seat back strength should be designed to

enhance occupant safety in real-world crashes.

GM agreed with an upgrade of Standard No. 207 seat back strength requirements in the future. However, GM stated that this should be done in a separate rulemaking.

VW commented that a single optimal level of seat back strength is extremely difficult to define because of the range in impact severity (a function of impact speed and the impacting vehicle structure in real-world crash situations).

Advocates stated:

Advocates thinks it would be difficult for the agency to justify instituting the proposed rear impact fuel integrity test without reforming Standard No. 207 to prevent seat back collapse while also ensuring much better head restraint protection against whiplash injuries. It is obvious that it is unacceptable to propose a new crash test in which the majority of seatbacks in the test vehicles collapse or occupants suffer severe whiplash injuries in seats which maintain their upright positions. * * * Advocates is concerned that, in the short term, manufacturers may simply increase seat back strength, especially rigidity, to prevent seat backs from collapsing in the new No. 301 rear impact test.

4. Use of 5th Percentile Female Dummies

In the NPRM, the agency asked whether it should require vehicles to meet the requirements of Standard No. 301 in tests with 5th percentile female dummies as well as with the currently-required 50th percentile male dummies.

The Alliance, DC, GM, VW, and Ford opposed requiring the use of 5th percentile female dummies in Standard No. 301 rear impact tests. The Alliance stated that different dummy sizes would only change the total impact weight of the tested vehicles and would have little or no effect on the performance of the fuel system. However, GM supported the voluntary use of instrumented test dummies for research to understand better the mechanics and magnitude of the potential for injury for various dummy sizes in different crash situations.

Advocates supported requiring the use of 5th percentile female dummies in the proposed rear impact test procedure. Advocates stated this would help prevent occupant injury due to ramp up of the seat back. In addition, Advocates suggested that the agency require use of the 95th percentile male dummy in Standard No. 301 rear impact tests to help prevent occupant injury due to seat back failure.

5. Test Vehicle Loading Conditions

In the NPRM, the agency proposed to eliminate the second sentence of

¹⁹ The agency notes that it docketed a detailed list of all the rear impact crash test results discussed in the NPRM and other related dockets. See Docket No. NHTSA-99-5825-1, June 8, 1999.

S7.1.6(b) of Standard No. 301. That sentence reads:

If the weight on any axle, when the vehicle is loaded to unloaded vehicle weight plus dummy weight, exceeds the axle's proportional share of the test weight, the remaining weight shall be placed so that the weight on that axle remains the same.

The Alliance, Ford, and VW opposed the elimination of that sentence. The Alliance stated:

The 136 kg load specified for impact testing by FMVSS [Federal Motor Vehicle Safety Standard] 301 is relatively small for many trucks. Even with this load directly over the rear axle, the test axle loads will generally not be in the same proportions as the specified GAWRs [gross axle weight ratings] for a full-sized truck. The second sentence allows the manufacturer to conduct the test when the conditions specified in the first sentence cannot be met.

VW recommended that the agency incorporate the load distribution provisions of S7.1.6(b), which apply to multipurpose passenger vehicles, trucks, and buses, in S7.1.6(a), which applies to passenger cars. VW also suggested that the text of S7.1.6(a) and (b) be clarified to state that the weight placement and attachment must be out of the vehicle crush zone and done in a manner that does not interfere with vehicle crash deformation.

GM recommended that the agency revise the test vehicle loading conditions to read as follows:

Passenger cars. A passenger car is loaded to its unloaded vehicle weight plus the weight of the necessary anthropomorphic test devices, plus its rated cargo and luggage capacity weight, secured in the luggage area.

Multipurpose passenger vehicles, trucks, and buses. A multipurpose passenger vehicle, truck, or bus is loaded to its unloaded vehicle weight plus the weight of the necessary anthropomorphic test devices, plus 136 kilograms or its rated cargo and luggage capacity weight, whichever is less, secured in the load carrying area and distributed as nearly as possible in proportion to its gross axle weight ratings. For the purposes of this standard, unloaded vehicle weight does not include the weight of work-performing accessories.

GM also recommended that the agency replace the language in S8.1.1 of Standard No. 208, S6.1 of Standard No. 212, S7.7 of Standard No. 219, S7.1.6 of Standard No. 301, S7.1.6 of Standard No. 303, and S7.2.3 of Standard No. 305 with the same language as that quoted above.²⁰ GM stated that these changes would facilitate common understanding, eliminate any ambiguity

that might be due to any differences in the language of these standards, parallel the wording of the test procedure, and agree with the agency's intent for the loading conditions to be consistent.

6. Lowering the Barrier Face

In the NPRM, the agency proposed that the MDB that would be used in the proposed rear impact test procedure upgrade be the same as the one shown in Figure 2 of Standard No. 214, except that the barrier face would be 50 mm (2 inches) lower. The agency requested comments on this proposed change.

DC, GM, and Ford supported the proposed lowering of the barrier face for rear impact testing. The Alliance and VW, however, questioned NHTSA's proposal to lower the barrier face for the rear impact testing. VW commented that the statistics used by NHTSA to justify the proposed change had not been verified. VW also stated,

The speed distribution of rear end crashes in which pre-impact braking might occur has not been fully addressed and it is possible that pre-impact braking of either the target vehicle or the impacting vehicle or both is not as common as NHTSA assumes in the high speed rear impact crashes that the very severe upgraded rear crash test is intended to address.

7. Pole Side Impact Test

In the NPRM, the agency noted that the side collision fire rate for passenger cars, light trucks, and vans is highest when a narrow object is struck. Thus, the agency asked whether it would be reasonable to consider a pole side impact test as part of a subsequent upgrading of Standard No. 301.

The Alliance, DC, GM, Ford, and Porsche opposed a pole side impact test. The Alliance stated that NHTSA would need to provide a full assessment of the safety basis if the agency undertook such a rulemaking. The Alliance also stated that the agency would need to propose a detailed test procedure, including pole contact locations, closing velocities, pole sizes, and modes of testing.

DC commented that any potential benefits of a pole side impact test "would be far outweighed by the added counter measures that such testing would require." DC stated:

We believe that the benefits to real world safety and the scope and magnitude, and impact on motor vehicle design of such requirements would need to be verified through detailed studies, testing, and be evaluated by the agency prior to consideration of such potentially invasive regulation with apparent major impact on motor vehicles. We believe that such studies would not demonstrate an appreciable benefit in overall real world occupant safety.

Advocates supported adding a pole side impact test to Standard No. 301. Advocates stated,

Such a test would provide concurrent safety information on both upper and lower interior occupant protection (because of severe side structure deformation and localized intrusion), door integrity both during and after the crash, and of fuel system integrity.

8. Prohibiting Fuel Leakage in Frontal Impact Crash Tests

In the NPRM, the agency asked whether it should amend Standard No. 301 to prohibit fuel leakage in any crash test performed under Standard No. 208.

The Alliance and GM supported a future revision limiting fuel system leakage in any Standard No. 208 crash test to current Standard No. 301 requirements, if a meaningful safety benefit could be determined.

DC and Ford opposed a fuel leakage requirement in Standard No. 208 crash tests.

Advocates commented that the rates of fuel release and quantities currently permitted by Standard No. 301 are not consonant with fire prevention and occupant safety following a crash. Advocates recommended that the agency should show the real-world consequences of the rates and amounts of fuel spillage permitted by Standard No. 301, and, if the amounts are judged to be too lenient, revise them to minimize the chances of a post-crash fire.

IIHS and Dynamic Safety recommended that the agency adopt frontal offset crash test requirements in Standard No. 301. IIHS stated, "Frontal offset deformable barrier crash tests create deformation patterns commonly found in severe real-world crashes. The offset loading challenges the vehicle's ability to retain its structural integrity."

9. Compliance Responsibility of Second-Stage Manufacturers

In the NPRM, the agency noted that there are a large number of second-stage manufacturers that could be affected by the proposed rule. Second-stage manufacturers buy a chassis from a first-stage manufacturer and finish it to the consumer's specifications. The manufacturers that put a work-related body on a pickup truck chassis (such as a small tow truck) often perform manufacturing operations affecting the fuel system, both in the structure around the fuel tank and where the fuel filler neck attaches to the body. Other second-stage manufacturers use a van chassis or an incomplete vehicle for ambulances, small mobile homes, small school buses, etc.

²⁰ GM recommended that the following sentence be included in the language for Standard Nos. 208, 212, and 219: "Vehicles are tested to a maximum unloaded vehicle weight of 2,495 kilograms."

Typically, the first-stage manufacturer provides the second-stage manufacturer with a body builder's guide that tells the second-stage manufacturer what additions or other modifications it can make and still either pass along the original equipment manufacturer's certification for compliance with Standard No. 301 (for chassis cabs) or otherwise be confident that the vehicle will comply (for other types of incomplete vehicles). To the extent that a second-stage manufacturer deviates from the guide, it would have to certify compliance on its own.

In the NPRM, the agency tentatively concluded that few final stage manufacturers would deviate from the body builder's guide.

The National Truck Equipment Association (NTEA)²¹ disagreed with this tentative conclusion. The NTEA commented:

It is not inconceivable that a major upgrade of the standard could force a chassis manufacturer to forbid the completion of certain chassis with certain body types or equipment in order to reduce their liability to an acceptable level. In any event, it will be impossible for the chassis manufacturers to test or even envision all types of multi-stage vehicles and will likely allow no modifications of any sort while leaving as much liability with the final stage manufacturer as possible, even when no fuel system modifications are made by the final stage manufacturer.

The NTEA stated that the proposed upgrade of Standard No. 301 could require second-stage manufacturers to conduct compliance testing, and that since most second-stage manufacturers are small businesses, such testing would be an unreasonable burden.²²

10. Fuel Siphoning

Dynamic Safety, IIHS, and Advocates all raised the issue of fuel siphoning after a fuel line is breached. Dynamic Safety stated:

Any fuel system integrity standard upgrade should address the issue of fuel line siphoning. The standard should require that vehicles not siphon fuel if a fuel line is breached.

Dynamic Safety commented that anti-siphon devices are readily available. Dynamic Safety stated that Ford and DC have been using fuel return line one-way check valves (known as "duckbill valves") on many of their vehicles since the 1980s, and that GM has installed

"siphon break" holes in some of its passenger car fuel return lines since the late 1980s.

IIHS stated, "The Institute strongly supports implementation of requirements designed to stop the flow of fuel after a collision." Advocates strongly supported research into and consideration of fuel system flow interdiction through the use of various technologies, such as electric current shut-off devices that stop fuel pump delivery after a crash and manual or electrical inertia switches and check valves to block fuel delivery.

V. Final Rule

A. Summary of the Final Rule

The amendments in this final rule are essentially the same as those proposed in the NPRM, but with compliance requirements for the rear impact upgrade to be phased-in. Instead of providing that all vehicles must comply at the end of a several year period, as proposed in the NPRM, the agency is providing that compliance with the rear impact upgrade will be phased-in over an additional three-year period, without credits for early compliance. The lead time for the side impact upgrade is the same as proposed.

As proposed in the NPRM, the final rule establishes a rear impact test procedure that specifies striking the rear of the test vehicle at 80 ± 1 km/h (50 mph) with a 1,368 kilogram (3,015 pound) MDB at a 70 percent overlap with the test vehicle. The MDB is located 50 millimeters (2 inches) lower than the face of the Standard No. 214 barrier to simulate pre-crash braking. This replaces the 48 km/h rear moving barrier crash test previously required under S6.2 of Standard No. 301.

Also as proposed, the final rule eliminates Standard No. 301's side crash test and replaces it with the side impact crash test currently specified in Standard No. 214. S6.3 of Standard No. 301 had required a vehicle's side to be impacted by a barrier moving at 48 km/h. This final rule incorporates into S6.3 the side impact crash test in Standard No. 214, which is also amended by the final rule to specify that a stationary vehicle be struck on either side by a 1,368 kg (3,015 pound) MDB moving at a speed of 53 ± 1 km/h.

NHTSA notes that while it has conducted research to explore the desirability of revising the Standard No. 214 barrier, additional research would have to be conducted before the agency could decide whether proposing a revision might be worthwhile. Thus, even if a revision were ultimately adopted, it could not be implemented

until well beyond the implementation of this upgrade to Standard No. 301.

Instead of providing that all vehicles comply at the end of a several year period, as proposed in the NPRM, the agency is providing that compliance with the rear impact upgrade will be phased in by increasing percentages of production over an additional three-year period, without credits for early compliance or compliance above the required percentages.

At least 40 percent of vehicles manufactured on or after September 1, 2006, but before September 1, 2007, must comply with the new rear impact requirements. At least 70 percent of the vehicles manufactured on or after September 1, 2007, but before September 1, 2008, will have to comply, and starting September 1, 2008, all vehicles manufactured will have to comply with the upgraded rear impact requirements. The final rule amends 49 CFR Part 586, establishing reporting and record keeping requirements concerning the phase-in. However, vehicles manufactured in two or more stages will not be required to meet the rear impact upgrade requirements until September 1, 2008, when all vehicles must be certified as complying.

All vehicles manufactured on or after September 1, 2004, must comply with the upgraded side impact requirements.

B. Rear Impact Test Procedure

After reviewing real-world fire-related crash data, various vehicle offset crash tests, and the comments, NHTSA is adopting the rear impact test procedure as proposed. The final rule replaces Standard No. 301's current rear impact test procedure with one that specifies striking the rear of the test vehicle at 80 ± 1 km/h (50 mph) with a 1,368 kilogram (3,015 pound) MDB at a 70 percent overlap with either side of the test vehicle. The MDB face is located 50 millimeters (2 inches) lower than the face of the Standard No. 214 barrier to simulate pre-crash braking.

The agency is not adopting DC's recommended impact speed of 56–64 km/h for the reasons stated in the NPRM. Namely, the agency believes that the upgraded test procedure will simulate a type of rear vehicle-to-vehicle collision that can result in post-crash fire in an otherwise survivable crash: a high speed offset rear strike to the vehicle that results in fuel leakage from a breach in the fuel system and, potentially, a rapidly spreading fire that results in fatalities and injuries. As NHTSA noted in the NPRM, NASS estimates show that the majority of fatal and nonfatal occupant burn injuries in rear impact crashes were in the 34 to 48

²¹ The NTEA represents second-stage manufacturers, most of whom are small businesses.

²² The NTEA submitted several conformity statements from first-stage manufacturers as evidence that the certification responsibilities of second-stage manufacturers would change as a result of this rulemaking.

km/h (21 to 30 mph) delta-v range. The agency believes that the offset rear impact test procedure specified in this final rule will simulate vehicle-to-vehicle crashes with a delta-v range of 32 to 48 km/h (20 to 30 mph).

The agency is also not adopting the recommendations of DC, GM, and Ford to specify design changes to the MDB and cart system. DC, GM, and Ford commented that, in their rear impact testing under the proposed test procedure, the MDB honeycomb appeared to bottom out. NHTSA, in the rear impact testing that it conducted in support of this rulemaking, took detailed post-crash test honeycomb crush measurements. None of the measurements indicated complete bottoming out of the honeycomb, and only a few of the measurements indicated about 85 percent compression.

Honeycomb, by design, is limited to approximately 85 percent compression, at which point it begins to stiffen considerably until it becomes infinitely stiff at 90–95 percent compression. During the 85–90 percent compression phase, it is similar to vehicle structures that become progressively stiffer as the crush in a crash increases. The measurements that were at 85 percent compression were observed near the edges of the MDB face, and since the total area was miniscule compared to the overall block of honeycomb, there will be little or no effect on the total or local forces exerted. Therefore, the energy absorbing honeycomb element has fully served its function of spreading the loads to the soft and hard structures of the vehicle and dissipating its share of the crash energy by the time that nearly full compression occurs. Accordingly, the agency believes that bottoming out of the honeycomb is not a concern.

DC, GM, and Ford also commented that, in their rear impact testing, the uprights supporting the cart face inadvertently contacted the struck vehicle. None of the commenters provided details on specific tests. However, the agency observed such contact in several of its rear impact tests. The NHTSA tests were conducted with the Standard No. 214 barrier, which has uprights that extend approximately 100 mm (4 inches) above the backing plate. The agency conducted film analysis of its tests and found there was no contact between the uprights and any significant vehicle structural components. The only vehicle components that contacted the uprights were trunks or tailgates that were already deformed. These contacts came late in the crash event and did not influence the outcomes.

The agency also notes that GM conducted several rear impact crash tests with a non-Standard No. 214 barrier. The cart used by GM had uprights extending approximately 600 mm (24 inches) above the backing plate, or 20 inches taller than the uprights on the barrier used by NHTSA. Despite this significant difference, there was no difference in the GM and NHTSA test results. Accordingly, the agency believes that contact between the cart uprights and the struck vehicle is not a concern.

GM noted that in some of its tests the barrier face underrode the struck vehicle and, upon rebound, the upright that contacted the vehicle became “caught” on vehicle structure (*e.g.*, bumper, frame cross member, *etc.*), with undetermined effects on the struck vehicle. Ford stated that, in some of its tests, right angle corners of the barrier face hung up on vehicle trim, potentially affecting test repeatability.

NHTSA did not observe either of these phenomena in any of its testing. The agency notes that the top edge of the deformable element of the barrier is 31 inches above the ground. Consequently, for the barrier face to underride the struck vehicle, the rear end of the vehicle would have to be lifted approximately 20 to 24 inches off the ground. The agency believes that such lifting is highly unlikely. Moreover, the agency believes that any possible effects from the phenomena observed by GM and Ford would be secondary since they occur after the maximum crush damage of the test. The agency notes that damage to the fuel systems tested by NHTSA and GM appeared to result from crush damage rather than from any secondary damage. Accordingly, the agency believes that the points raised by GM and Ford are not of concern.

NHTSA is not adopting VW’s suggestion to not lower the barrier face by 50 mm (2 inches) to simulate pre-crash braking. NHTSA has determined that this change will have no measurable effect on the performance of the barrier.²³ The agency’s tests indicate that the center of gravity of the barrier will drop about 7.4 mm (0.29 inches), which is well within the 25.4 mm (1 inch) allowed tolerance for center of gravity locations. The moment of inertia of the barrier about the longitudinal (roll) and transverse (pitch) axes will be reduced 0.1 percent and 0.02 percent, respectively, and there will be no change in the vertical (yaw) axis. The

²³ The agency has docketed its findings on which this determination is based. See Docket No. NHTSA-00-8248, entry 3.

agency notes that the device currently used to measure these parameters is not capable of measuring such small changes in the moment of inertia. Moreover, these small changes will not produce any measurable effect on the test results.

The agency is not adopting the recommendation of Advocates, IIHS, and AAD to specify the use of a heavier (4,000 pound) barrier because, as the agency noted in the NPRM, in an 80 km/h (50 mph) rear impact offset crash test, a 3,015-pound barrier effectively reproduces the damage profile seen in real world crashes that most often lead to fires. If a heavier barrier were used, the proposed rear impact crash test would no longer reproduce that profile. In addition, the agency has conducted its crash tests in support of this rulemaking with a 3,015-pound barrier. The agency would have to conduct further research and development before a heavier barrier could be proposed for use in any test procedure.²⁴

Honda claimed that the MDB overrode the rear of the test vehicle but was not specific about the vehicle test in which the override occurred. We presume that Honda may have examined the test film of a Honda Accord test conducted by GM under the GM C/K settlement agreement with NHTSA. While NHTSA personnel made suggestions and witnessed the testing, we did not have direct control over the conduct of the tests. The Standard No. 301 upgrade test protocol was not precisely followed, but was instead modified according to what GM believed to be a worst case. Two major exceptions to the Standard No. 301 upgrade protocol were the test speed and the barrier height. GM believed that testing near the Standard No. 214 height and at 85 km/h would provide a worst case scenario. In GM’s test with the Honda Accord, there was indeed severe override, which we believe was due to the additional 2.5 inches in the height of the MDB face, and to a lesser degree the additional speed of the test.

VW also recommended that the proposed rear impact test be on the side of the vehicle where the filler pipe is located. Our test results indicated that fuel leakage is not dependent on the location of the filler pipe; rather, it is dependent on how the overall fuel system is protected against the impact. Therefore, we are not incorporating

²⁴ The agency notes that the impact with the 3,015-pound barrier at 50 mph produces an impact energy 2.09 times greater than the impact energy produced by the current Standard No. 301 test. If the agency specified the use of a 4,000-pound barrier at 50 mph, the impact energy would be 2.78 times greater than the current Standard No. 301 test.

VW's suggestion and vehicles must comply when the rear impact test is conducted on either side of the vehicle.

Further, our cost study indicated that compliance with this final rule will not require major structural redesign (as stated by Alliance and DC), or necessitate an increase in vehicle stiffness (as stated by VW). Because there is no need to increase the vehicle stiffness, this final rule does not increase the potential for whiplash injuries in lower crashes as suggested by VW.

C. Side Impact Test Procedure

The agency is replacing Standard No. 301's current lateral crash test with the side impact crash test specified in Standard No. 214. The Standard No. 214 side impact crash test specifies that a stationary vehicle be struck on either side by a 1,368 kg (3,015 pound) MDB. As noted above, Standard No. 214 currently specifies an impact speed of 54 km/h. In order to provide an appropriate tolerance without affecting the stringency of the test, the agency proposed to change the test speed to 53 ± 1 km/h and adopt it for Standard No. 301. No comments addressed this issue, and we are adopting that proposal.

The agency is specifying that the MDB be lowered 50 mm (2 inches) for the rear impact test to simulate pre-braking. However, the agency is not specifying that the MDB be lowered for the side impact test. The test conditions of Standard No. 214 were intended to reflect a "worst case" scenario for occupants riding in the struck vehicle in that the striking vehicle was assumed not to be braking prior to impact. A braking vehicle would strike lower than a non-striking vehicle, potentially engaging more of the side sill of the struck vehicle. Full engagement of the sill dissipates the crush energy more effectively than engagement of the door structures located above the sill, resulting in less intrusion and deformation along the struck side where fuel system components (e.g., fuller filler neck and tube) are located. NHTSA believes the integrity of those fuel system components would be tested in a more severe environment if the barrier were not lowered. For these reasons, NHTSA has decided not to lower the MDB for the side impact test.

D. Door System Integrity

NHTSA believes that a post-crash door operability requirement could be a practicable, reasonable safety enhancement. However, the agency has decided not to add a post-crash door operability requirement to Standard No. 301 or Standard No. 206 in this

rulemaking. The agency has not developed a practical, objective, and repeatable test procedure for testing door operability. The agency is specifically concerned with developing specifications for the type and magnitude of force needed to test door operability. The agency notes that none of the commenters who supported a door operability requirement suggested a test procedure.

Accordingly, NHTSA will need to conduct research before proposing any post-crash door operability requirement and will consider adding a post-crash door operability requirement to Standard No. 206 or Standard No. 301 in a separate rulemaking.

E. Lead Time

1. Rear Impact Test Upgrade

In the Preliminary Regulatory Evaluation for the NPRM, the agency said that most vehicles needing modification to meet the upgrade rear impact test would need only minor modifications and estimated that those modifications could be completed in 33 months. Based on that estimate, we provided a lead time of three years.

The Alliance said "significant vehicle redesign and retooling for production will likely be required in a number of vehicles." It suggested "(t)he small number of tests conducted by the NHTSA, often with a sample size of one vehicle, simply is inadequate to identify whether vehicle changes are required or for any manufacturer to assure compliance for all its vehicles." The Alliance suggested that the agency phase in the requirements, beginning not earlier than three years after the issuance of the final rule, according to the following annually increasing percentages of production: 25%, 40%, 70% and 100%.

In their comments on the NPRM, DC and Honda argued that some vehicles would need more than just minor modifications and that therefore additional lead time should be provided. Both suggested that the entire rear ends of some vehicles would have to be redesigned, although neither identified any specific models in need of such changes. Honda generally cited crash testing in support of its argument, but gave no details about that testing. DC suggested the same phase-in recommended by the Alliance. Honda suggested that the agency phase in the requirements, beginning not earlier than three years after the issuance of the final rule, according to the following percentages of production: 10%, 30%, 70% and 100%.

While the agency continues to believe that a three-year lead time is sufficient for most vehicles in need of modification, it agrees that it is desirable to provide additional lead time to accommodate any new models that were designed and developed based upon the current requirements. The agency recognizes that vehicle platforms, once developed, are typically used for a number of years without major structural modification. We also recognize that in order to meet the requirements of FMVSS No. 301, a vehicle, without modification, must meet the static roll over requirements following an impact in a barrier test. Consequently, we have decided that the upgraded rear impact test will be phased-in, beginning on September 1, 2006, according to the following percentages of production: 40%, 70% and 100%. We believe that this combination of lead time and phase-in will allow sufficient time for existing platforms to be redesigned to comply with all of the requirements of FMVSS No. 301, and that the four year phase-in proposed by the Alliance is not necessary.

We also believe that it is not necessary to allow an optional "0%, 0%, 100%" three-year phase-in for limited-line manufacturers as proposed by Porsche. A similar phase-in exception for limited line manufacturers is present for the advanced air bag requirements of Standard No. 208. However, the advanced technology requirements that compounded the disparity between the phase-in requirements of the Advanced Air Bag Rule for limited line manufacturers and more diverse manufacturers is not present here.

2. Side Impact Test Upgrade

In the Preliminary Regulatory Evaluation for the NPRM, we said:

Since almost all vehicles pass the Standard No. 214 test without fuel leakage and all manufacturers have done these tests on their passenger cars and light trucks and vans up to 6,000 pounds GVWR, the agency is proposing a one year leadtime after the final rule for implementing the Standard No. 214 test requirement for the lateral test.

Some vehicle manufacturers supported the one-year lead time proposed in the NPRM for the side impact test upgrade, but recommended that the agency add a phase-in after this lead time. The Alliance asked for additional lead time for vehicles not previously subject to Standard No. 214, saying:

Until a complete and thorough evaluation program is completed for each model, the actual and exact extent of changes to each

vehicle cannot be ascertained. For this reason, we recommend that vehicles not previously subject to FMVSS 214 requirements also have the same three-year lead time and four year phase-in schedule as proposed above for the rear impact requirement, with the allowance for early compliance. Starting the lead time and the phase-in for both the rear and side impact requirements at the same time would also be logical and provide clarity since both are contained in the single notice.

As we note below in the section on costs, only one out of more than 100 vehicles tested failed Standard No. 301's fuel leakage requirements using Standard No. 214's side impact test. Based on those test results, the agency believes that few vehicles, approximately 1%, will have to be modified to meet Standard No. 301's leakage requirements using Standard No. 214's side impact test. Therefore, the one-year lead time without a phase-in is adopted, as was proposed.

F. Benefits

The target population of crashes includes multi-vehicle crashes in which a passenger vehicle is struck in the rear by another passenger vehicle and the fire starts in the struck vehicle. There are an estimated 58 burn-related fatalities and 119 non-fatal burn-related injuries annually in the target population. The non-fatal burn injuries in that population of crashes were mostly minor and were typically not the most severe injury to the occupant. The agency estimates that approximately 8 to 21 fatalities will be prevented once all vehicles on the road comply with the upgraded rear impact test. The cost per life saved is estimated to be \$1.96 million to \$5.13 million (\$41 million/21 lives to \$41 million/8 lives). The agency is not estimating the number of reduced non-fatal burn-related injuries because there are only a few cases each year in which the injured person's most serious injury was a burn injury.

There are fewer than 100 fatalities annually in multi-vehicle side impacts that result in fire. The agency believes that the Standard No. 214 side impact test is somewhat stricter than the existing lateral impact test in Standard No. 301. However, the agency was unable to quantify any benefits from switching to the Standard No. 214 side impact test.

NHTSA disagrees with the VW comment that the benefits of this rulemaking are too low compared to its costs. VW did not provide any data to support their comment. However, the agency believes that VW's cost estimates may be based on costs of issues, such as post-crash door operability, seat back failures, and dummy responses, which

were discussed in the NPRM but not adopted in this final rule.

G. Costs

The agency estimates that the average cost for vehicles that will need to be modified to comply with the upgraded rear impact test is \$5.31 per vehicle.²⁵ Based on its belief that the test failures in the agency's testing were more the result of design differences than vehicle weight differences, the agency estimates that 46 percent of the vehicle fleet does not currently meet the upgraded rear impact test. It further estimates that approximately 16.7 million vehicles are sold each year in the U.S. Together, this information indicates that the total cost for the fleet will be approximately \$41 million per year.

Using the Standard No. 214 side impact test as the Standard No. 301 side impact test will eliminate the cost of conducting a unique Standard No. 301 test as well as the cost of an extra test vehicle. Since the average current Standard No. 301 side impact test is roughly \$4,300 and the average test vehicle costs about \$21,000, the total savings would be about \$25,200 per vehicle model.²⁶

Only one out of more than 100 vehicles tested failed Standard No. 301's fuel leakage requirements using Standard No. 214's side impact test. Based on those test results, the agency believes that few vehicles will have to be modified to meet Standard No. 301's side impact leakage requirements using Standard No. 214's side impact test.

NHTSA disagrees with the Honda comment that the agency's cost estimates are too low. The agency's cost estimates are based on the changes that will be needed to remedy those noncompliant vehicles needing only minor modifications. Since most vehicles readily pass the fuel leakage requirements using the Standard No. 214 side impact test, we do not believe modifications will be required which are not minor. Neither Honda nor any of the other vehicle manufacturers provided data indicating that the costs of modifying vehicles to comply will be greater than the agency's estimates.²⁷ Furthermore, 54 percent of the vehicles tested were able to pass at the higher test speed and the measures required to

²⁵ This is a \$0.31 increase from the figure used in the NPRM.

²⁶ The figures in the NPRM were \$4,000 for the average lateral test for Standard No. 301 costs, \$20,000 for average test vehicle cost, and a total of about \$24,000 per vehicle model.

²⁷ The agency believes that Honda's cost estimates are overstated since they include vehicle models that complied with the amendments in this final rule when the agency tested them.

address the failing vehicles do not involve structural changes.

H. Additional Issues

1. Real World Data

None of the commenters provided any real-world data on the relationship between crash severity and the risk of occupant injury due to fire. Thus, as discussed above in the section on Costs and Benefits, it appears that the data files NHTSA used in developing the NPRM are the best available data sources.

2. Head and Neck Injury Criteria

The agency agrees with the Alliance's comment that the issue of occupant protection would best be discussed in the context of a rulemaking focused on that issue. The agency notes that it is in the process of developing a final rule for Standard No. 202 and a proposed rule for Standard No. 207, and will address rear impact protection in those rulemakings.

3. Seat Back Failure

NHTSA agrees with the DC comment that the issue of seat back failure best be discussed in the context of a rulemaking focused on that issue. The agency notes that it is considering an upgrade of Standard No. 207, where this issue will be addressed.

4. Use of 5th Percentile Female Dummies

NHTSA agrees with the GM comment that using various dummy sizes to study the safety consequences to vehicle occupants due to the rear impact test upgrade should be a subject for future research. The agency will address the use of various dummy sizes in rear impact tests in separate rulemakings.

5. Test Vehicle Loading Conditions

The agency is adopting GM's suggested revision of S7.1.6(b) of Standard No. 301. That paragraph is revised to read as follows:

S7.1.6(b) Except as specified in S7.1.1, a multipurpose passenger vehicle, truck, or bus with a GVWR of 4,536 kg or less is loaded to its unloaded vehicle weight, plus the necessary test dummies as specified in S6, plus 136 kg or its rated cargo and luggage capacity weight, whichever is less, secured in the load carrying area and distributed as nearly as possible in proportion to its GAWR. For the purpose of this standard, unloaded vehicle weight does not include the weight of work-performing accessories. Each dummy is restrained only by means that are installed in the vehicle for protection at its seating position.

This provision is revised to simplify the language and provide clearer

instruction as to how weight is to be distributed on a vehicle under test conditions. NHTSA is not adopting Alliance's recommendation to retain the language that addressed distribution when the axle's proportional share is exceeded. While the revised provision eliminates that language, it does provide that weight is to be distributed as *nearly as possible* in proportion to the GAWR.

NHTSA is not adopting GM's recommendation that the agency replace the language in S8.1.1 of Standard No. 208, S6.1 of Standard No. 212, S7.7 of Standard No. 219, S7.1.6 of Standard No. 301, S7.1.6 of Standard No. 303, and S7.2.3 of Standard No. 305 with identical language. The agency believes that such revisions are outside the scope of this rulemaking. However, the agency will treat GM's recommendation as a petition for rulemaking and will make a decision on whether or not to grant the petition within the next 120 days.

NHTSA is also not adopting GM's and VW's suggested revision of S7.1.6(a). The agency believes that the language in that paragraph is sufficiently clear.

6. Lowering the Barrier Face

For the reasons discussed above in the section on Rear Impact Test Procedure, the agency is specifying that the barrier face in the rear impact test procedure is lowered 50 mm (2 inches).

7. Pole Side Impact Test

NHTSA agrees with the comments from the Alliance, GM, DC, Porsche, and Ford that the agency must assess the safety basis for a pole side impact test, as well as develop an objective, repeatable test procedure, including pole contact locations, closing velocities, pole sizes, and modes of testing, before the agency proposes such a test. Any future proposals to utilize a pole side impact test will address these issues.

8. Prohibiting Fuel Leakage in Frontal Impact Crash Tests

NHTSA agrees with the comments from the Alliance and GM that the agency should consider a future revision limiting fuel system leakage in any Standard No. 208 crash test to the levels currently specified in Standard No. 301. In frontal impacts at 35 mph (56 km/hr) into the barrier, there have been 10 failures out of 406 NCAP (New Car Assessment Program) tests, since 1979. While rare, the agency will continue to monitor fuel system leakage in the NCAP tests to determine whether future upgrades would be appropriate.

9. Compliance Responsibility of Second-Stage Manufacturers

NHTSA believes that there will be no change to the certification responsibilities of second-stage and final-stage manufacturers as a result of this rulemaking. The agency has reviewed the conformity statements from first-stage manufacturers submitted by the NTEA and believes them to be reasonable. Under these conformity statements, the first-stage manufacturer installs the entire fuel system, and the second-stage or final-stage manufacturer can make minor alterations without violating the pass-through certification from the first-stage manufacturer.²⁸ Further, vehicles manufactured in two or more stages will not be required to comply with the rear impact upgrade until the final stage of the phase-in.

In cases in which the second-stage or final-stage manufacturers make significant changes to the fuel system, they may not be able to use the pass-through certification, and may have to certify that the vehicle complies with Standard No. 301. If it is not economically feasible for these manufacturers to perform the compliance testing or engineering analysis, the manufacturers may apply for a temporary exemption under 49 CFR Part 555.

The agency also notes that it is currently involved in a negotiated rulemaking process with the NTEA, first-stage manufacturers, and other stakeholders regarding the certification process for vehicles manufactured in two or more stages. The agency intends to develop changes to the regulations governing the certification of such vehicles through this process.

10. Fuel Siphoning

The issues raised by Dynamic Safety concerning fuel siphoning and by IIHS and Advocates concerning fuel cutoff devices all pertain to frontal fire protection. NHTSA research identified rear impacts as the most common type of crashes that result in fires. The agency would need to conduct research to determine the extent of the problem related to fuel siphoning as described by Dynamic Safety. If future NHTSA analysis of real-world crash data indicates that there is a safety problem that warrants further regulatory action, the agency will consider additional changes to Standard No. 301. The

²⁸ The first-stage manufacturer typically certifies that the incomplete vehicle meets the requirements of Standard No. 301. This relieves second-stage or final-stage manufacturers of the burden of conducting Standard No. 301 compliance tests, unless those manufacturers make substantial changes to the fuel system.

agency notes that preliminary research of frontal impacts under the GM settlement agreement indicated that the vehicles equipped with fuel cutoff devices performed similarly to vehicles without such devices. Consequently, the agency does not anticipate that any real world benefits would result if the agency required fuel cutoff devices.

VI. Rulemaking Analyses and Notices

A. Executive Order 12866 and DOT Regulatory Policies and Procedures

Executive Order 12866, "Regulatory Planning and Review" (58 FR 51735, October 4, 1993), provides for making determinations whether a regulatory action is "significant" and therefore subject to OMB review and to the requirements of the Executive Order. The Order defines a "significant regulatory action" as one that is likely to result in a rule that may:

(1) Have an annual effect on the economy of \$100 million or more or adversely affect in a material way the economy, a sector of the economy, productivity, competition, jobs, the environment, public health or safety, or State, local, or tribal governments or communities;

(2) Create a serious inconsistency or otherwise interfere with an action taken or planned by another agency;

(3) Materially alter the budgetary impact of entitlements, grants, user fees, or loan programs or the rights and obligations of recipients thereof; or

(4) Raise novel legal or policy issues arising out of legal mandates, the President's priorities, or the principles set forth in the Executive Order.

NHTSA has considered the impact of this final rule under E.O. 12866 and the Department of Transportation's regulatory policies and procedures and has determined that it is not significant.

NHTSA has prepared a Final Regulatory Evaluation (FRE) describing the economic and other effects of this final rule.²⁹ If only minor modifications are needed to comply with the upgraded rear impact test, the agency estimates that the average cost for vehicles that will need to be modified is \$5.31 per vehicle. The agency estimates that 46 percent of the vehicle fleet does not currently meet the upgraded rear impact test and that approximately 16.7 million vehicles are sold each year in the U.S. Together, this information indicates that the total cost for the fleet will be approximately \$41 million per year. To the extent that any vehicles need more than minor modifications, the total cost may be higher. However, none of the

²⁹ A copy of the FRE has been placed in the docket.

commenters provided data indicating that the cost of remedying noncompliant vehicles will be greater than the agency's estimates. Using the Standard No. 214 side impact test as the Standard No. 301 side impact test will eliminate the cost of conducting a unique Standard No. 301 test as well as the cost of an extra test vehicle. The total savings would be about \$25,200 per vehicle model.

B. Regulatory Flexibility Act

Pursuant to the Regulatory Flexibility Act (5 U.S.C. 601 *et seq.*, as amended by the Small Business Regulatory Enforcement Fairness Act (SBREFA) of 1996), whenever an agency is required to publish a notice of rulemaking for any proposed or final rule, it must prepare and make available for public comment a regulatory flexibility analysis that describes the effect of the rule on small entities (*i.e.*, small businesses, small organizations, and small governmental jurisdictions). The Small Business Administration's regulations at 13 CFR part 121 define a small business, in part, as a business entity "which operates primarily within the United States." (13 CFR 121.105(a)). No regulatory flexibility analysis is required if the head of an agency certifies the rule will not have a significant economic impact on a substantial number of small entities. SBREFA amended the Regulatory Flexibility Act to require Federal agencies to provide a statement of the factual basis for certifying that a rule will not have a significant economic impact on a substantial number of small entities.

NHTSA has considered the effects of this final rule under the Regulatory Flexibility Act. I certify that this final rule will not have a significant economic impact on a substantial number of small entities. The rationale for this certification is that the amendments made in this final rule primarily affect manufacturers of passenger cars and light trucks. These manufacturers typically do not qualify as small entities under 5 U.S.C. 605(b).

NHTSA estimates that there are about four small manufacturers of passenger cars in the U.S., and no small manufacturers of light trucks, producing a combined total of at most 500 vehicles each year. It is unknown how many of their vehicle models will meet the amendments made in this final rule. The agency requested comments on this issue in the NPRM, but received none.

As discussed above in the section on Compliance Responsibility of Second-Stage Manufacturers, there are a large number of second-stage and final-stage

manufacturers. The agency believes that there will be no change to the certification responsibilities of second-stage and final-stage manufacturers as a result of this rulemaking.

Consequently, the agency has concluded that this rulemaking will not have a significant economic impact on a substantial number of small entities.

C. National Environmental Policy Act

NHTSA has analyzed this rulemaking action for the purposes of the National Environmental Policy Act. The agency has determined that implementation of this rule will not have any significant impact on the quality of the human environment.

D. Executive Order 13132 (Federalism)

Executive Order 13132 requires NHTSA to develop an accountable process to ensure "meaningful and timely input by State and local officials in the development of regulatory policies that have federalism implications." "Policies that have federalism implications" is defined in the Executive Order to include regulations that have "substantial direct effects on the States, on the relationship between the national government and the States, or on the distribution of power and responsibilities among the various levels of government." Under Executive Order 13132, the agency may not issue a regulation with Federalism implications, that imposes substantial direct compliance costs, and that is not required by statute, unless the Federal government provides the funds necessary to pay the direct compliance costs incurred by State and local governments, the agency consults with State and local governments, or the agency consults with State and local officials early in the process of developing the regulation. NHTSA also may not issue a regulation with Federalism implications and that preempts State law unless the agency consults with State and local officials early in the process of developing the regulation.

The agency has analyzed this final rule in accordance with the principles and criteria set forth in Executive Order 13132 and has determined that it will not have sufficient federalism implications to warrant consultation with State and local officials or the preparation of a federalism summary impact statement. The final rule will not have any substantial effects on the States, or on the current Federal-State relationship, or on the current distribution of power and responsibilities among the various local officials.

E. Civil Justice Reform

This final rule will not have any retroactive effect. Under 49 U.S.C. 30103, whenever a Federal motor vehicle safety standard is in effect, a State may not adopt or maintain a safety standard applicable to the same aspect of performance which is not identical to the Federal standard, except to the extent that the state requirement imposes a higher level of performance and applies only to vehicles procured for the State's use. 49 U.S.C. 30161 sets forth a procedure for judicial review of final rules establishing, amending, or revoking Federal motor vehicle safety standards. That section does not require submission of a petition for reconsideration or other administrative proceedings before parties may file suit in court.

F. Paperwork Reduction Act

Under the procedures established by the Paperwork Reduction Act of 1995, a person is not required to respond to a collection of information by a Federal agency unless the collection displays a valid OMB control number. For the phase-in reporting requirements, which were not proposed in the notice of proposed rulemaking, but are added in this Final Rule, NHTSA is submitting to OMB a request for approval of the following collection of information. Public comment is sought on the proposed collection.

Agency: National Highway Traffic Safety Administration (NHTSA).

Title: Phase-In Production Reporting Requirements for Fuel Systems Integrity Upgrade.

Type of Request: New collection.

OMB Clearance Number: None assigned.

Form Number: This collection of information will not use any standard forms.

Requested Expiration Date of Approval: Three years from the date of approval.

Summary of the Collection of Information

So that NHTSA can ensure that vehicle manufacturers are certifying their applicable vehicles as meeting the rear impact test upgrades that are specified in this final rule, in this proposed collection, NHTSA would require vehicle manufacturers to provide reports on compliance of their vehicles with the rear impact test upgrade.

For the rear impact test upgrade, NHTSA established a six year schedule; a three year lead time, then a 3-year phase-in period during which, in the

first year, 40% of the applicable vehicles must meet the rear impact test upgrade, and in the second and third years, 70% and 100% respectively.

For each year of the rear impact test phase-in period, manufacturers must, within 60 days after the end of the "production year," provide to NHTSA information identifying the vehicles (by make, model, and vehicle identification number (VIN)) that have been certified as complying with the rear impact test upgrade. Furthermore, until December 31, 2009, each manufacturer must maintain records of the VIN for each vehicle for which information is reported.

Description of the Need for the Information and Proposed Use of the Information

NHTSA requires this information to ensure that vehicle manufacturers are certifying their applicable vehicles as meeting the new rear impact test upgrades that are specified in this final rule. NHTSA will use this information to determine whether a manufacturer has complied with the amended requirements of Standard No. 301 during the phase-in period.

Description of the Likely Respondents (Including Estimated Number, and Proposed Frequency of Response to the Collection of Information)

NHTSA estimates that 21 vehicle manufacturers will submit the required information. The manufacturers are makers of passenger cars, multipurpose passenger vehicles, trucks and buses that have gross vehicle weight ratings of 4,536 kg (10,000 pounds) or less, and use fuel with a boiling point above 0 degrees Celsius. For each report, the manufacturer will provide, in addition to its identity, several numerical items of information. This information would include:

- (a) Total number of vehicles manufactured for sale during the preceding production year,
- (b) Total number of vehicles manufactured during the production year that meet the new regulatory requirements, and
- (c) Information identifying the vehicles (by make, model, and vehicle identification number (VIN)) that have been certified as complying with the side impact test upgrade or the rear impact test upgrade.

During the phase-in period, each manufacturer will provide 1 report per year for three years for the rear impact phase-in, for a total of 3 reports over 3 years.

Estimate of the Total Annual Reporting and Recordkeeping Burden Resulting From the Collection of Information

NHTSA estimates that each manufacturer will incur two burden hours per year per report. This estimate is based on the fact that data collection will involve only computer tabulation and that manufacturers will provide the information to NHTSA in an electronic (as opposed to paper) format. Thus, for the rear impact test upgrade reporting, each manufacturer will incur a burden of two hours or a total on industry of 42 hours a year (assuming there are 21 manufacturers) to provide the rear impact test upgrades.

NHTSA estimates that the recordkeeping burden resulting from the collection of information will be 0 hours because the information will be retained on each manufacturer's existing computer systems for each manufacturer's internal administrative purposes.

NHTSA estimates that the total annual cost burden will be 1050 dollars (42 total annual burden hours \times 25 dollars/hour). There would be no capital or start-up costs as a result of this collection. Manufacturers can collect and tabulate the information by using existing equipment. Thus, there would be no additional costs to respondents or recordkeepers.

NHTSA requests comment on its estimates of the total annual hour and cost burdens resulting from this collection of information. Please submit any comments to the NHTSA Docket Number referenced in the heading of this notice or to: Dr. William J. J. Liu, Office of Crashworthiness Standards, National Highway Traffic Safety Administration, 400 Seventh St., SW., Washington, DC 20590. Dr. Liu's telephone number is: (202) 366-2264. Comments are due by January 30, 2004.

G. National Technology Transfer and Advancement Act

Section 12(d) of the National Technology Transfer and Advancement Act of 1995 (NTTAA), Pub. L. 104-113, section 12(d) (15 U.S.C. 272) directs NHTSA to use voluntary consensus standards in its regulatory activities unless doing so would be inconsistent with applicable law or otherwise impractical. Voluntary consensus standards are technical standards (*e.g.*, materials specifications, test methods, sampling procedures, and business practices) that are developed or adopted by voluntary consensus standards bodies, such as the Society of Automotive Engineers (SAE). The NTTAA directs NHTSA to provide

Congress, through OMB, explanations when the agency decides not to use available and applicable voluntary consensus standards.

There are no voluntary consensus standards available at this time. However, NHTSA will consider any such standards when they become available.

H. Unfunded Mandates Reform Act

Section 202 of the Unfunded Mandates Reform Act of 1995 (UMRA) requires Federal agencies to prepare a written assessment of the costs, benefits, and other effects of proposed or final rules that include a Federal mandate likely to result in the expenditure by State, local, or tribal governments, in the aggregate, or by the private sector, of more than \$100 million in any one year (adjusted for inflation with base year of 1995). Before promulgating a rule for which a written statement is needed, section 205 of the UMRA generally requires NHTSA to identify and consider a reasonable number of regulatory alternatives and adopt the least costly, most cost-effective, or least burdensome alternative that achieves the objectives of the rule. The provisions of section 205 do not apply when they are inconsistent with applicable law. Moreover, section 205 allows NHTSA to adopt an alternative other than the least costly, most cost-effective, or least burdensome alternative if the agency publishes with the final rule an explanation why that alternative was not adopted.

This final rule will not result in the expenditure by State, local, or tribal governments, in the aggregate, or by the private sector, of more than \$100 million annually. Consequently, no Unfunded Mandates assessment has been prepared.

I. Regulation Identifier Number (RIN)

The Department of Transportation assigns a regulation identifier number (RIN) to each regulatory action listed in the Unified Agenda of Federal Regulations. The Regulatory Information Service Center publishes the Unified Agenda in April and October of each year. You may use the RIN contained in the heading at the beginning of this document to find this action in the Unified Agenda.

J. Privacy Act

Anyone is able to search the electronic form of all submissions received into any of our dockets by the name of the individual submitting the comment (or signing the comment, if submitted on behalf of an association, business, labor union, *etc.*). You may

review DOT's complete Privacy Act Statement in the **Federal Register** published on April 11, 2000 (Volume 65, Number 70; Pages 19477-78) or you may visit <http://dms.dot.gov>.

List of Subjects

49 CFR Part 571

Imports, Motor vehicle safety, Reporting and recordkeeping requirements, Tires.

49 CFR Part 586

Reporting and recordkeeping requirements.

■ In consideration of the foregoing, NHTSA is amending 49 CFR part 571 and revising part 586 as follows:

PART 571—FEDERAL MOTOR VEHICLE SAFETY STANDARDS

■ 1. The authority citation for part 571 continues to read as follows:

Authority: 49 U.S.C. 322, 30111, 30115, 30117, and 30166; delegation of authority at 49 CFR 1.50.

■ 2. In § 571.214, paragraphs S3(b), (c), (d), and (f) are revised to read as follows:

§ 571.214 Standard No. 214; Side impact protection.

* * * * *

S3 *Requirements.* (a) * * *

(b) When tested under the conditions of S6, each passenger car manufactured on or after September 1, 1996, shall meet the requirements of S5.1, S5.2, and S5.3 in a 53 ± 1.0 km/h impact in which the car is struck on either side by a moving deformable barrier. 49 CFR part 572, subpart F test dummies are placed in front and rear outboard seating position on the struck side of the car. However, the rear seat requirements do not apply to passenger cars with a wheelbase greater than 3,300 mm, or to passenger cars that have rear seating areas that are so small that 49 CFR part 572, subpart F test dummies cannot be accommodated according to the positioning procedure specified in S7.

(c) [Reserved].

(d) [Reserved].

(e) * * *

(f) When tested according to the conditions of S6, each multipurpose passenger vehicle, truck, and bus manufactured on or after September 1, 1998, shall meet the requirements of S5.1, S5.2, and S5.3 in a 53 ± 1.0 km/h impact in which the vehicle is struck on either side by a moving deformable barrier. A 49 CFR part 572, subpart F test dummy is placed in the front outboard seating position on the struck side of the vehicle, and if the vehicle is equipped with rear seats, then another 49 CFR part 572, subpart F test

dummy is placed in the outboard seating position of the second seat on the struck side of the vehicle. However, the second seat requirements do not apply to side-facing seats or to vehicles that are so small that the 49 CFR part 572, subpart F test dummy cannot be accommodated according to the procedure specified in S7.

* * * * *

■ 3. In § 571.301, paragraphs S6.2, S6.3, S7.1.6(b), S7.2, and S7.3 are revised, paragraph S8 is added, and Figure 3 is added following Figure 2, to read as follows:

§ 571.301 Standard No. 301; Fuel system integrity.

* * * * *

S6.2 *Rear moving barrier crash.* (a) *Vehicles manufactured before September 1, 2006.* When the vehicle is impacted from the rear by the barrier specified in S7.3(a) of this standard moving at 48 km/h, with 50th percentile test dummies as specified in part 572 of this chapter at each front outboard designated seating position, under the applicable conditions of S7, fuel spillage must not exceed the limits of S5.5.

(b) *Vehicles manufactured on or after September 1, 2006.* When the vehicle is impacted from the rear by a moving deformable barrier 80 ± 1.0 km/h with a 70 percent overlap, with 50th percentile test dummies as specified in part 572 of this chapter at each front outboard designated seating position, under the applicable conditions of S7, fuel spillage must not exceed the limits of S5.5.

S6.3 *Side moving barrier crash.* (a) *Vehicles manufactured before September 1, 2004.* When the vehicle is impacted laterally on either side by a barrier moving at 32 km/h with 50th percentile test dummies as specified in part 572 of this chapter at positions required for testing to Standard No. 208 (49 CFR 571.208), under the applicable conditions of S7, fuel spillage must not exceed the limits of S5.5.

(b) *Vehicles manufactured on or after September 1, 2004.* When the vehicle is impacted laterally on either side by a moving deformable barrier at 53 ± 1.0 km/h with 49 CFR part 572, subpart F test dummies at positions required for testing by S3(b) of Standard No. 214, under the applicable conditions of S7 of this standard, fuel spillage shall not exceed the limits of S5.5 of this standard.

* * * * *

S7.1.6 * * *

(a) * * *

(b) Except as specified in S7.1.1, a multipurpose passenger vehicle, truck,

or bus with a GVWR of 4,536 kg or less is loaded to its unloaded vehicle weight, plus the necessary test dummies as specified in S6, plus 136 kg or its rated cargo and luggage capacity weight, whichever is less, secured in the load carrying area and distributed as nearly as possible in proportion to its GAWR. For the purpose of this standard, unloaded vehicle weight does not include the weight of work-performing accessories. Each dummy is restrained only by means that are installed in the vehicle for protection at its seating position.

* * * * *

S7.2 *Side moving barrier test conditions.* (a) *Vehicles manufactured before September 1, 2004.* The side moving barrier crash test conditions are those specified in S8.2 of Standard No. 208 (49 CFR 571.208).

(b) *Vehicles manufactured on or after September 1, 2004.* The side moving deformable barrier crash test conditions are those specified in S6 and S7 of Standard No. 214 (49 CFR 571.214).

S7.3 *Rear moving barrier test conditions.* (a) *Vehicles manufactured before September 1, 2006.* The rear moving barrier test conditions are those specified in S8.2 of Standard No. 208 (49 CFR 571.208), except for the positioning of the barrier and the vehicle. The barrier and test vehicle are positioned so that at impact—

(1) The vehicle is at rest in its normal attitude;

(2) The barrier is traveling at 48 km/h with its face perpendicular to the longitudinal centerline of the vehicle; and

(3) A vertical plane through the geometric center of the barrier impact surface and perpendicular to that surface coincides with the longitudinal centerline of the vehicle.

(b) *Vehicles manufactured on or after September 1, 2006.* The rear moving deformable barrier is the same as that shown in Figure 2 of Standard No. 214 (49 CFR 571.214) and specified in 49 CFR part 587, except as otherwise specified in paragraph S7.3 (b). The barrier and test vehicle are positioned so that at impact—

(1) The vehicle is stationary;

(2) The deformable face of the barrier is mounted on the barrier 50 mm (2 inches) lower than the height from the ground specified in Figure 2 of Standard No. 214 (49 CFR 571.214) (All dimensions from the ground in Figure 2, Front View should be reduced by 50 mm (2 inches.);)

(3) The barrier is traveling 80 ± 1.0 km/h; and

(4) The barrier impacts the test vehicle with the longitudinal centerline

of the vehicle parallel to the line of travel and perpendicular to the barrier face within a tolerance of ± 5 degrees. The test vehicle and barrier face are aligned so that the barrier strikes the rear of the vehicle with 70 percent overlap toward either side of the vehicle. So aligned, the barrier face fully engages one half of the rear of the vehicle and partially engages the other half. At impact, the vehicle's longitudinal centerline is located inboard either of the side edges of the barrier by a distance equal to 20 percent of the vehicle's width ± 50 mm (see Figure 3). The vehicle's width is the maximum dimension measured across the widest part of the vehicle, including bumpers and molding, but excluding such components as exterior mirrors, flexible mud flaps, marker lamps, and dual rear wheel configurations.

* * * * *

S8 Phase-In schedule.

S8.1 Rear impact test upgrade. (a) Vehicles manufactured on or after September 1, 2006 and before September 1, 2007. For vehicles manufactured on or after September 1, 2006, and before September 1, 2007, the number of vehicles complying with S6.2(b) of this standard must not be less than 40 percent of:

(1) The manufacturer's average annual production of vehicles manufactured on

or after September 1, 2003, and before September 1, 2006; or
(2) The manufacturer's production on or after September 1, 2005, and before September 1, 2006.

(b) Vehicles manufactured on or after September 1, 2007 and before September 1, 2008. For vehicles manufactured on or after September 1, 2007 and before September 1, 2008, the number of vehicles complying with S6.2(b) of this standard must not be less than 70 percent of:

(1) The manufacturer's average annual production of vehicles manufactured on or after September 1, 2004, and before September 1, 2007; or

(2) The manufacturer's production on or after September 1, 2006, and before September 1, 2007.

(c) Vehicles manufactured on or after September 1, 2008. For vehicles manufactured on or after September 1, 2008, the number of vehicles complying with S6.2(b) of this standard must be 100 percent of the manufacturer's production during that period.

S8.2 Vehicles manufactured in two or more stages. A final stage manufacturer or alterer may, at its option, comply with the requirements set forth in S8.2.1 and S8.2.2.

S8.2.1 Vehicles manufactured on or after September 1, 2006 and before September 1, 2008 are not required to comply with the requirements specified in S6.2(b) of this standard.

S8.2.2 Vehicles manufactured on or after September 1, 2008 shall comply with the requirements specified in S6.2(b) of this standard.

S8.3 Vehicles produced by more than one manufacturer.

S8.3.1 For the purpose of calculating average annual production of vehicles for each manufacturer and the number of vehicles manufactured by each manufacturer under S8.1, a vehicle produced by more than one manufacturer must be attributed to a single manufacturer as follows, subject to S8.3.2:

(a) A vehicle that is imported must be attributed to the importer.

(b) A vehicle manufactured in the United States by more than one manufacturer, one of which also markets the vehicle, must be attributed to the manufacturer that markets the vehicle.

S8.3.2 A vehicle produced by more than one manufacturer must be attributed to any one of the vehicle's manufacturers specified by an express written contract, reported to the National Highway Traffic Safety Administration under 49 CFR part 590, between the manufacturer so specified and the manufacturer to which the vehicle would otherwise be attributed under S8.3.1.

* * * * *

BILLING CODE 4910-59-P

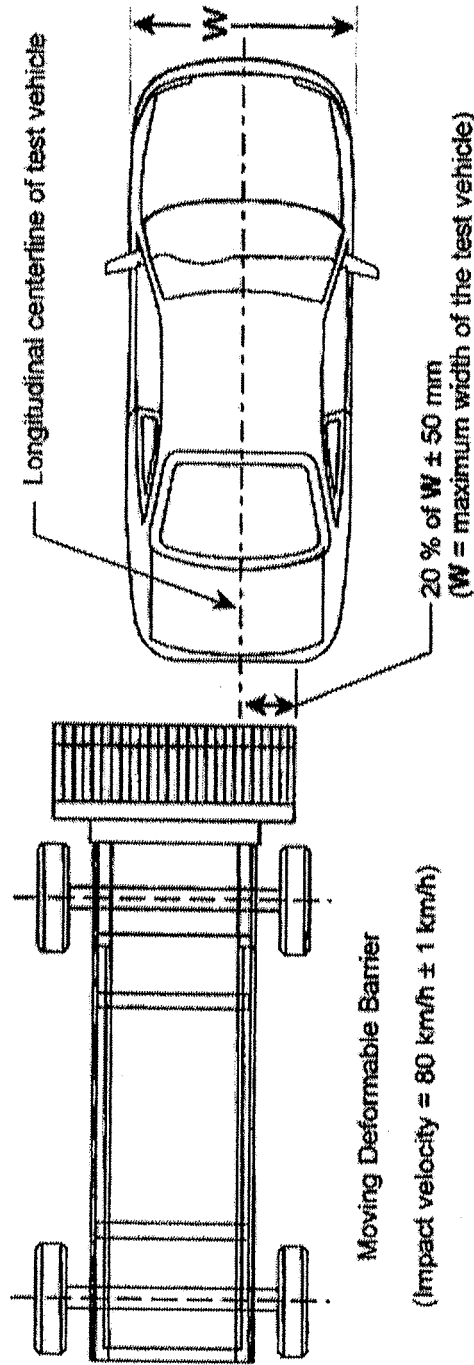

FIGURE 3 – MOVING DEFORMABLE BARRIER REAR IMPACT - 70 % OVERLAP

■ 4. Part 586 is revised to read as follows:

PART 586—FUEL SYSTEM INTEGRITY UPGRADE PHASE-IN REPORTING REQUIREMENTS

Sec.

- 586.1 Scope.
- 586.2 Purpose.
- 586.3 Applicability.
- 586.4 Definitions.
- 586.5 Response to inquiries.
- 586.6 Reporting requirements.
- 586.7 Records.
- 586.8 Petition to extend period to file report.

Authority: 49 U.S.C. 322, 30111, 30115, 30117, and 30166; delegation of authority at 49 CFR 1.50.

§ 586.1 Scope.

This part establishes requirements for manufacturers of passenger cars, multipurpose passenger vehicles, trucks, and buses with a gross vehicle weight rating of 4,536 kilograms (10,000 pounds) or less to submit a report, and maintain records related to the report, concerning the number of such vehicles that meet the upgraded requirements of Standard No. 301, *Fuel systems integrity* (49 CFR 571.301).

§ 586.2 Purpose.

The purpose of these requirements is to assist the National Highway Traffic Safety Administration in determining whether a manufacturer has complied with the upgraded requirements of Standard No. 301 (49 CFR 571.301).

§ 586.3 Applicability.

This part applies to manufacturers of passenger cars, multipurpose passenger vehicles, trucks, and buses with a gross vehicle weight rating of 4,536 kilograms (10,000 pounds) or less.

§ 586.4 Definitions.

(a) All terms defined in 49 U.S.C. 30102 are used in their statutory meaning.

(b) *Bus, gross vehicle weight rating, multipurpose passenger vehicle, passenger car, and trucks* are used as defined in 49 CFR 571.3.

(c) *Production year* means the 12-month period between September 1 of one year and August 31 of the following year, inclusive.

§ 586.5 Response to inquiries.

At any time during the production years ending August 31, 2007, August 31, 2008, and August 31, 2009, each manufacturer must, upon request from the Office of Vehicle Safety Compliance, provide information identifying the vehicles (by make, model, and vehicle identification number) that have been certified as complying with S6.2(b) of

Standard No. 301 (49 CFR 571.301). The manufacturer's designation of a vehicle as a certified vehicle is irrevocable.

§ 586.6 Reporting requirements.

(a) *Phase-in reporting requirements.* Within 60 days after the end of the production years ending August 31, 2007, August 31, 2008, and August 31, 2009, each manufacturer must submit a report to the National Highway Traffic Safety Administration concerning its compliance with S6.2(b) of Standard No. 301 (49 CFR 571.301) for its passenger cars, multipurpose passenger vehicles, trucks, and buses with a gross vehicle weight rating of less than 4,536 kilograms (10,000 pounds) produced in that year. Each report must—

- (1) Identify the manufacturer;
- (2) State the full name, title, and address of the official responsible for preparing the report;
- (3) Identify the production year being reported on;
- (4) Contain a statement regarding whether or not the manufacturer complied with the requirements of S6.2(b) of Standard No. 301 (49 CFR 571.301) for the period covered by the report and the basis for that statement;
- (5) Provide the information specified in paragraph (b) of this section;
- (6) Be written in the English language; and
- (7) Be submitted to: Administrator, National Highway Traffic Safety Administration, 400 Seventh Street, SW., Washington, DC 20590.

(b) *Phase-in report content.*

(1) *Basis for statement of compliance.* Each manufacturer must provide the number of passenger cars, multipurpose passenger vehicles, trucks, and buses with a gross vehicle weight rating of 4,536 kilograms (10,000 pounds) or less manufactured for sale in the United States for each of the three previous production years, or, at the manufacturer's option, for the previous production year. A new manufacturer that has not previously manufactured these vehicles for sale in the United States must report the number of such vehicles manufactured during the current production year.

(2) *Production.* Each manufacturer must report for the production year for which the report is filed: the number of passenger cars, multipurpose passenger vehicles, trucks, and buses with a gross vehicle weight rating of 4,536 kilograms (10,000 pounds) or less that meet S6.2(b) or S6.3(b) of Standard No. 301 (49 CFR 571.301).

(3) *Vehicles produced by more than one manufacturer.* Each manufacturer whose reporting of information is affected by one or more of the express

written contracts permitted by S8.3.2 of Standard No. 301 (49 CFR 571.301) must:

(i) Report the existence of each contract, including the names of all parties to the contract, and explain how the contract affects the report being submitted.

(ii) Report the actual number of vehicles covered by each contract.

§ 586.7 Records.

Each manufacturer must maintain records of the Vehicle Identification Number for each vehicle for which information is reported under § 586.6(b)(2) until December 31, 2010.

§ 586.8 Petition to extend period to file report.

A manufacturer may petition for extension of time to submit a report under this part. A petition will be granted only if the petitioner shows good cause for the extension and if the extension is consistent with the public interest. The petition must be received not later than 15 days before expiration of the time stated in § 586.6(a). The filing of a petition does not automatically extend the time for filing a report. The petition must be submitted to: Administrator, National Highway Traffic Safety Administration, 400 Seventh Street, SW., Washington, DC 20590.

Issued: November 21, 2003.

Jeffrey W. Runge,
Administrator.

[FR Doc. 03-29805 Filed 11-25-03; 1:17 pm]

BILLING CODE 4910-59-P

DEPARTMENT OF COMMERCE

National Oceanic and Atmospheric Administration

50 CFR Part 679

[Docket No. 030804191-3286-02; I.D. 071603A]

RIN 0648-AR31

Fisheries of the Exclusive Economic Zone Off Alaska; Allocation of Pacific Cod Among Fixed Gear Sectors

AGENCY: National Marine Fisheries Service (NMFS), National Oceanic and Atmospheric Administration (NOAA), Commerce.

ACTION: Final rule.

SUMMARY: NMFS issues a final rule to implement Amendment 77 to the Fishery Management Plan for the Groundfish Fishery of the Bering Sea and Aleutian Islands Area (FMP). This