

UNITED  
NATIONS

E



**Economic and Social  
Council**

~~Distr.~~  
~~GENERAL~~

~~TRANS/WP.29/GRSP/2005/3~~  
~~7 March 2005~~

~~Original: ENGLISH~~  
~~ENGLISH AND FRENCH ONLY~~

ECONOMIC COMMISSION FOR EUROPE

INLAND TRANSPORT COMMITTEE

World Forum for Harmonization of Vehicle Regulations (WP.29)

Working Party on Passive Safety (GRSP)  
(Thirty-seventh session, 23-27 May 2005,  
agenda item A.1.)

PROPOSAL FOR A GLOBAL TECHNICAL REGULATION ON  
UNIFORM PROVISIONS CONCERNING THE APPROVAL OF VEHICLES WITH REGARD  
TO THEIR CONSTRUCTION IN ORDER TO IMPROVE THE PROTECTION AND  
MITIGATE THE SEVERITY OF INJURIES TO PEDESTRIANS AND OTHER  
VULNERABLE ROAD USERS IN THE EVENT OF A COLLISION

Transmitted by the informal group on pedestrian safety

---

Note: This document is distributed to the Experts on Passive Safety only.

B. TEXT OF THE REGULATION

1. PURPOSE ~~AND SCOPE.~~

1.1. The purpose of this **global technical** regulation is to bring about an improvement in the construction of the fronts of vehicles and, in particular, those areas which have been most frequently identified as causing injury when in collision with a pedestrian or other vulnerable road user. ~~The tests required are limited to those elements of the child and adult body most frequently identified as sustaining injury, i.e. the adult head and leg and the child head. To achieve the required improvements in construction of vehicles, the tests are based on sub-system component impactors representing those body regions and impacted at speeds representative of that below which the majority of injuries occur.~~

1.2. The vehicles to be tested under the regulation are representative of the majority of vehicles in circulation in the urban environment, where there is a greater potential for collision with pedestrians and other vulnerable road users, and include passenger cars, vans and light trucks.

2. ~~Application~~ APPLICATION SCOPE

To be rephrased by OICA:

- ~~2.1. This global technical regulation requires specified tests to be completed for the purpose of qualifying vehicles, including passenger cars, vans and light trucks, with respect to the safety of pedestrians and other vulnerable road users. This global technical regulation (gtr) shall apply to the frontal surfaces of power driven vehicles of category 1-1 with a gross vehicle mass not exceeding 2.5 tonnes, and of category 2 with a gross vehicle mass not exceeding 2.5 tonnes, derived from category 1-1. All definitions of Special Resolution 1 shall apply as necessary. It shall not apply to vehicles of category 1-1 or category 2 with a gross vehicle weight which does not exceed 0.5 tonnes.~~

For the purpose of this gtr, vehicles of category 2 derived from category 1-1 means vehicles of category 2 which, forward of the A pillars, have the same general structure and shape as a pre-existing category 1-1 vehicle.

- ~~2.2. This global technical regulation applies to those categories of vehicles as detailed in Table 1 below. All Contracting Parties agreeing to this global technical regulation will indicate, in the table, the vehicle categories and test requirements to be applied in their region.~~
- ~~*The grey coloured cells of Table 1 indicate for which vehicle category the respective tests are validated. It is depending on the Contracting Parties and their responsibility to select the application of the global technical regulation taking into account the need to validate the test procedure and the requirements for the selected vehicle categories based on the results of studies conducted among others in the framework of EEVC and IHRA.*~~
- ~~*As this will be the final document, it should already be decided what is to be applied by each Contracting Party. It should be hoped that any tests included have been validated for use within the regulation. Thus the following is suggested as a replacement clause.*~~
- ~~{2.2. This global technical regulation applies to those categories of vehicles as detailed in Table 1 below. For each Contracting Party, the vehicle categories and test requirements to be applied in their region are indicated in the table.}~~
- ~~2.3. Regular reviews will be instituted to ensure the eventual application of this global technical regulation to all vehicles in a reduced set of suitable vehicle categories, on the basis of technical and economic feasibility, for all Contracting Parties.~~
- ~~2.4. Regular reviews will be instituted to ensure that the specifications of the test requirements will be harmonized into a single set of requirements accepted by all Contracting Parties.~~

~~2.5. At the time of acceptance of the regulation by any Contracting Party to the regulation, that Contracting Party will be required to accept the alternatives available at that time.~~

~~2.6. Those tests accepted by any Contracting Party may be phased in with respect to the date of acceptance of the GTR gtr by that Contracting Party. The details of the phasing in periods shall be stated and appended to the regulation~~

*This table will provide information on the tests to be applied and the vehicles to which they will be applied in those regions/Contracting Parties entered into the table cells. The categories of vehicle should reflect that which will be agreed under the terms of Special Resolution No. 1 (S.R.1) and may be adjusted to allow the requirements to be applied selectively.*

*Columns (a) & (b) are as before allowing a break at the 2,500kg GVM*

*Column (e) no longer makes reference to 'derived from' as this is not a clear recognized category and is not necessary here – there is still the cut off point at 3,500kg GVM.*

*Column (d) now reads for the suggested category 2-1 which has a limit of 3,500kg GVM.*

*The shading is removed from the cells as any test included should be validated before inclusion.*

<b>Vehicle Categories</b>						
	(a)	(b)	(c)	(d)	(e)	(f)
<b>Procedure Application</b>	Category 1-1 GVM < 2500 kg	Category 1-1 GVM > 2500 kg	Category 1-2 GVM < 3500 kg	Category 2-1		
child headform test	Region x Region y Region z	Region y	---	---	---	---
adult headform test	Region x Region y	Region z	---	---	---	---
Legform to bumper	Region x	---	---	---	Region z	---
Upper legform to bumper	---	---	---	---	---	---
.....						

**Table 1: Agreed Scope and Application for the purposes of this Regulation.**

*The following notes should now be removed.*

[Notes:— Examples of Region: Region x covers all European Member states, Region y covers Japan, Region z covers the US, etc. for other contracting parties.

— The column of tests will continue for each potential agreed alternative test.

— The use of this approach still requires some guidance and approval from WP.29.]

3. DEFINITIONS-

When performing measurements as described in this Part, the vehicle should be positioned in its normal ride attitude.

If the vehicle is fitted with a badge, mascot or other structure which would bend back or retract under a low applied load, then such a load shall be applied before and/or while these measurements are taken.

Any vehicle component which could change shape or position, such as 'pop-up' headlights, other than suspension components or active devices to protect pedestrians, shall be set to a shape or position that the test institutes, in consultation with the manufacturer, consider to be the most appropriate while taking these measurements.

*All of this next paragraph should be removed from here as the elements are either already contained in or should be inserted under paragraph 6.2*

~~When performing measurements on a vehicle as described in this Part, the vehicle should be positioned in its normal ride attitude as described in paragraph 3.20. If the vehicle is fitted with a badge, mascot or other structure which would bend back or retract under a low applied load, then such a load shall be applied before and/or while these measurements are taken. [Any vehicle component which could change shape or position, such as 'pop-up' headlights, other than suspension components or active devices to protect pedestrians, shall be set to a shape or position, [based on a determination by each contracting party or regional economic integration organisation,] considered to be the most appropriate for use on public roads while taking these measurements.]~~

For the purposes of this regulation:

3.1. "Adult Headform Test Area" is an area on the outer surfaces of the front structure, as defined in paragraph 3.14.

The area is bounded, in the front, by a wrap around distance of 1700mm, as defined in paragraph 3.31, and, at the rear, by the rear reference line for adult headform, as defined in paragraph 3.21, and, at each side, by the side reference line as defined in paragraph 3.23.

3.2. "A-pillar" means the foremost and outermost roof support extending from the chassis to the roof of the vehicle.

~~3.3. "Bonnet angle" shall be the angle, relative to the horizontal plane, of a straight line connecting the points of intersection of the bonnet leading edge reference line and the bonnet rear reference line by a vertical longitudinal plane through the vehicle, at any designated lateral offset from the vehicle centreline. The angle designated by the manufacturer may be accepted as the bonnet angle, if it is within  $\pm 2^\circ$  of the actual measurement.~~

~~Figure 6 could be used to provide an example of the measured angle.~~

- 3.43. "Bonnet leading edge ~~(BLE)~~" means the front edge of the upper outer structure of the vehicle including the bonnet and wings, the upper and side members of the headlight surrounds and any other attachments. The reference line identifying the position of the bonnet leading edge is defined by its height above the ground reference plane and by the horizontal distance separating it from the bumper (bumper lead), ~~as determined in accordance with paragraphs 3.6, 3.15, and 3.10, respectively.~~
- 3.54. "Bonnet leading edge height ~~(BLEH)~~" means, at any point on the bonnet leading edge, the vertical distance between the ground reference plane and the bonnet leading edge reference line at that point, ~~as defined in paragraph 3.6,~~ with the vehicle positioned in its normal ride attitude

-

3.65. "Bonnet leading edge reference line" means the geometric trace of the points of contact between a straight edge 1000 mm long and the front surface of the bonnet, when the straight edge, held parallel to the vertical longitudinal plane of the car and inclined rearwards by 5040° from the vertical and with the lower end 600 mm above the ground, is traversed across and in contact with the bonnet leading edge (~~See-see~~ Figure 1.).

For vehicles having the bonnet top surface inclined at ~~essentially 5040°~~, so that the straight edge makes a continuous contact or multiple contacts rather than a point contact, determine the reference line with the straight edge inclined rearwards at an angle of 4035° from the vertical.

For vehicles of such shape that the bottom end of the straight edge makes first contact with the vehicle then that contact is taken to be the bonnet leading edge reference line, at that lateral position.

For vehicles of such shape that the top end of the straight edge makes first contact with the vehicle then the geometric trace of 1000 mm wrap around distance, ~~as defined in paragraph 3.31,~~ will be used as bonnet leading edge reference line at that lateral position.

The top edge of the bumper shall also be regarded as the bonnet leading edge ~~for this Regulation,~~ if it is contacted by the straight edge during this procedure.

3.76. "Bonnet rear reference line (BRL)" means the geometric trace of the most rearward points of contact between a 165\_-mm diameter sphere and the rear of the bonnetfront structure of the vehicle, when the sphere is traversed across the bonnet-front structure of the vehicle while maintaining contact with the lower windscreen (see Figure 2.).

Where the bonnet rear reference line and the side reference line do not intersect, the bonnet rear reference line should be extended and/or modified using a semi-circular template, of radius 100\_-mm. The template should be made of a thin flexible sheet material that easily bends to a single curvature in any direction. The template should, preferably, resist double or complex curvature where this could result in wrinkling. The recommended material is a foam backed thin plastic sheet to allow the template to "grip" the surface of the vehicle. The template should be marked up with four points "A" through "D", as shown in Figure 3, while the template is on a flat surface.

The template should be placed on the vehicle with Corners "A" and "B" coincident with the side reference line. Ensuring these two corners remain coincident with the side reference line, the template should be slid progressively rearwards until the arc of the template makes first contact with the bonnet rear reference line. Throughout the process, the template should be curved to follow, as closely as possible, the outer contour of the vehicle's bonnet op, without wrinkling or folding of the template. If the contact between the template and bonnet rear reference line is tangential and the point of tangency lies outside the



arc scribed by points "C" and "D", then the bonnet rear reference line is extended and/or modified to follow the circumferential arc of the template to meet the bonnet side reference line, as shown in Figure 4.

If the template cannot make simultaneous contact with the bonnet side reference line at points "A" and "B" and tangentially with the bonnet rear reference line, or the point at which the bonnet rear reference line and template touch lies within the arc scribed by points "C" and "D", then additional templates should be used where the radii are increased progressively in increments of 20 mm, until all the above criteria are met.

- 3.87. "Bonnet top" is the area which is bounded by (a), (b) and (c) as follows:
- (a) the bonnet leading edge reference line, ~~as defined in paragraph 3.6;~~
  - (b) the bonnet rear reference line, ~~as defined in paragraph 3.7;~~
  - (c) the bonnet side reference lines, ~~as defined in paragraph 3.23.~~
- 3.98. "Bumper" means the front, lower, outer structure of a vehicle. It includes all structures that are intended to give protection to a vehicle when involved in a low speed frontal collision with another vehicle and also any attachments to this structure. The reference height and lateral limits of the bumper are identified by the corners and the bumper reference lines, ~~as defined in paragraphs 3.12, 3.18, 3.19, 3.27, and 3.28.~~
- ~~3.409.~~ "Bumper lead" means, for any longitudinal section of a ~~car~~ vehicle ~~is~~, the horizontal distance in the vehicle longitudinal plane between the upper bumper reference line, ~~as defined in paragraph 3.28.~~ and the bonnet leading edge reference line, ~~as defined in paragraph 3.6.]~~
- 3.410. "Child Headform Test Area" is an area on the outer surfaces of the front structure, ~~as defined in paragraph 3.14.~~
- The area is bounded, in the front, by the front reference line for child headform, ~~as defined in paragraph 3.13,~~ and, at the rear, by the ~~rear reference line for child headform~~ WAD1700 line, ~~as defined in paragraph 3.22-3.31,~~ and by the side reference lines, ~~as defined in paragraph 3.23.~~
- 3.4211. "Corner of bumper" means the vehicle's point of contact with a vertical plane which makes an angle of 60° with the vertical longitudinal plane of the car and is tangential to the outer surface of the bumper (see Figure 5).
- 3.12. "vehicles of category 2 derived from category 1-1" means vehicles of category 2 which, forward of the A-pillars, have the same general structure and shape as a pre-existing category 1-1 vehicle.
- 3.13. "Front reference line for Child Headform ~~(CFL)~~" means the geometric trace as described on the vehicle front structure using a ~~wrap around distance of 1,000 mm.~~ WAD1000 line ~~as defined in paragraph 3.31.~~

In the case of vehicles where the wrap around distance to the bonnet leading edge reference line, ~~as defined in paragraph 3.6,~~ is more than 1,000 mm at any point, then the bonnet leading edge reference line will be used as the front reference line for child headform at that point.

3.14. "Front structure" means all ~~parts outer structures~~ of the vehicle including the windscreen, the windscreen header, the A-pillars and all parts of the vehicle forward of these. It therefore includes, but is not limited to, the bonnet, wings, scuttle ~~(cowl)~~, wiper spindles, windscreen and lower windscreen frame.

3.15. "Ground reference plane" means a flat horizontal plane, either real or imaginary, that passes through the lowest points of contact for all tyres of a vehicle while the vehicle is in its normal ride attitude. If the vehicle is resting on the ground, then the ground level and the ground reference plane are one and the same. If the vehicle is raised off the ground such as to allow extra clearance below the bumper, then the ground reference plane is above ground level.

3.16. "Head Injury Performance Criterion (HIC<sub>HPC</sub>)" means the calculated result of accelerometer time histories using the following formula:

$$\text{HIC}_{\text{HPC}} = \left[ \frac{1}{t_2 - t_1} \int_{t_1}^{t_2} a \, dt \right]^{2.5} (t_2 - t_1)$$

Where:

a is the resultant acceleration measured in units of gravity "g"  
(1g = 9.81m/s<sup>2</sup>);

t<sub>1</sub> and t<sub>2</sub> are the two time instants (expressed in seconds) during the impact, defining an interval between the beginning and the end of the recording period for which the value of HIC<sub>HPC</sub> is a maximum  
(t<sub>2</sub> - t<sub>1</sub> ≤ 15 msec)

3.17. "Impact point" means the point on the vehicle where initial contact by the test impactor occurs. The proximity of this point to the target point is dependent upon both the angle of travel by the test impactor and the contour of the vehicle surface (see point B in Figure 6).

3.18. "Lower bumper height" means the vertical distance between the ground reference plane and the lower bumper reference line, ~~as defined in paragraph 3.19,~~ with the vehicle positioned in its normal ride attitude.

3.19. "Lower bumper reference line" means the lower limit to significant points of pedestrian contact with the bumper. It is defined as the geometric trace of the lowermost points of contact between a straight edge 700-mm long and the

bumper, when the straight edge, held parallel to the vertical longitudinal plane of the car and inclined forwards by 25° from the vertical, is traversed across the front of the car, while maintaining contact with the ground and with the surface of the bumper (see Figure 7.).

3.20. "Normal ride attitude" means the vehicle attitude when it is at positioned on a flat horizontal surface with its mass in running order (as defined in Annex 3, paragraph 3 of Special Resolution 1), in driving order positioned on the ground, with the tyres inflated to manufacturer recommended pressures, the front wheels in the straight-ahead position, with maximum capacity of all fluids necessary for operation of the vehicle for use on public roads, with all standard equipment as provided by the vehicle manufacturer, with a 75 kg mass placed on the driver's seat, and and -with a 75 kg passenger mass placed on the front passenger seat (as defined in Annex 3, paragraph 6.2. of Special Resolution 1) placed on the front passenger seat. The front seats are placed at the nominal mid-track position., and the The suspension shall be set in normal running condition as specified by the manufacturer for a speed of 40km/hr (especially for vehicles with an active suspension or a device for automatic levelling). Refer to Special Resolution 1 §3 mass in running order and include seat in mid position.

3.21. "Rear reference line for Adult Headform (ARL)" means a geometric trace as described on the front structure of the vehicle using a wrap around distance of WAD-2,100 line as defined in paragraph 3.31, mm.

~~In the case of vehicles where the wrap around distance to the windscreen rear reference line, as defined in paragraph 3.35., is less than 2,100 mm at any point, the rear windscreen reference line will be used as the rear reference line for the adult headform at that point.~~

~~In the case of vehicles where the wrap around distance of 2,100 mm or the rear windscreen reference line, at any point, is above the vertical limit reference line, as defined in paragraph 3.30., at any point, then the vertical limit reference line will be used as the rear reference line for the adult headform at that point.~~

3.22. "Bumper test area" means the frontal surface of the bumper limited by two longitudinal vertical planes intersecting the corners of the bumper as defined in paragraph 3.12. and moved 66 mm parallel and inboard of the corners of the bumpers.

~~3.22. "Rear reference line for Child Headform (CRL)" means a geometric trace as described on the vehicle front structure by a wrap around distance of 1700 mm.~~

~~In the case of vehicles where the wrap around distance to the bonnet rear reference line, as defined in paragraph 3.7., is less than 1,700 mm at any point, then the bonnet rear reference line will be used as the rear reference line for the child headform at that point. In case the WAD1700 line, as defined in paragraph 3.31., is located in the windscreen test area, as defined in paragraph 3.36., at any point, the child headform test area is bounded by the WAD1700 line at the rear.~~

3.23. "Side reference line ~~(SL)~~" means the geometric trace of the highest points of contact between a straight edge 700 mm long and the sides of the front structure, A-pillars or roof vehicle, when the straight edge, held parallel to the transverse vertical plane of the vehicle and inclined inwards by 45° ~~and with the lower end 600 mm above the ground,~~ is traversed down, and maintains contact with, the sides of the front structure, A-pillars or roof, ~~while maintaining contact with the surface of the body shell~~ (see Figure 8.).

3.24. "Target Point" means the intersection of the projection of the headform longitudinal axis with the front surface of the vehicle (see point A in Figure 6.).

~~3.25.~~ "Third of the bonnet top" means the geometric trace between the bonnet side reference lines, ~~as defined in paragraph 3.23.~~, measured with a flexible tape following the outer contour of the bonnet top, divided into three equal parts.}]

~~3.26.~~ "Third of the bumper" means the geometric trace between the corners of the bumper, ~~as defined in paragraph 3.12.~~, measured with a flexible tape following the outer contour of the bumper, divided into three equal parts.}]

~~3.27.~~ "Upper bumper height" means the vertical distance between the ground reference plane and the upper bumper reference line, ~~as defined in paragraph 3.28.~~, with the vehicle positioned in its normal ride attitude.

~~3.28.~~ 'Upper Bumper Reference Line' means the upper limit to significant points of pedestrian contact with the bumper. For vehicles with an identifiable bumper structure it is defined as the geometric trace of the uppermost points of contact between a straight edge and the bumper, when the straight edge, held parallel to the vertical longitudinal plane of the car and inclined rearwards by 20° to the vertical, is traversed across the front of the car, while maintaining contact with the surface of the bumper (see Figure 9).

For vehicles with no identifiable bumper structure it is defined as the geometric trace of the uppermost points of contact between a straight edge 700mm long and the bumper area, when the straight edge, held parallel to the vertical longitudinal plane of the car and inclined rearwards by 20° from the vertical, is traversed across the front of the car, while maintaining contact with the ground and with the surface of the bumper area (see Figure 9).

~~"Upper bumper reference line" means the upper limit to significant points of pedestrian contact with the bumper. It is defined as the geometric trace of the uppermost points of contact between a straight edge 700 mm long and the bumper, when the straight edge, held parallel to the vertical longitudinal plane of the car and inclined rearwards by 20° from the vertical, is traversed across the front of the car, while maintaining contact with the ground and with the surface of the bumper (see Figure 9.). Where necessary the straight edge shall be shortened to avoid any contact with structures above the bumper.}]~~

~~3.29. "Vehicle mass" means the mass of the vehicle in running order, with the maximum capacity of all fluids necessary for the operation of the vehicle, fitted with the standard equipment as provided by the vehicle manufacturer and with no driver or passengers on board.~~

~~This next definition should be removed in line with the requirements of the Table 1. Paragraph numbers are renumbered as a consequence.~~

~~3.31. "Vehicles of category 2 derived from category 1.1" describes vehicles of category 2 which, forward of the A pillars, have the same general structure and shape as a pre-existing category 1.1 vehicle.~~

3.3029. "Vertical limit reference line (VLL)" means a horizontal line on the vehicle at a vertical height of 1900 mm from the ground reference plane (see Figure 10).

3.3430. "Wrap Around Distance (WAD)" ~~is means~~ the geometric trace described on the frontal upper surface of the vehicle by one end of a flexible tape, when it is held in a vertical fore and aft longitudinal plane of the vehicle and traversed across the front surfaces of the bonnet and bumper. ~~structure as defined in paragraph 3.14.~~ The tape is held taut throughout the operation with one end held at ground reference level, vertically below the front face of the bumper and the other end held in contact with the frontal upper surface ~~structure~~ (see Figure 11). The vehicle is positioned in the normal ride attitude.

This procedure shall be followed, using alternative tapes of appropriate lengths, to describe wrap around distances of 1 500 mm (WAD1000), of 1 700 mm (WAD1700) and of 2 100 mm (WAD2100).

3.3231. "Windscreen" means the frontal glazing of the vehicle situated between the A-pillars.

3.3332. "Windscreen lower reference line" means the trace of all points which are the most rearward of two points determined on any longitudinal vertical plane of the vehicle as follows (see Figure 13c):

- a point which is 82.5 mm rearward, on the windscreen surface, of the point of intersection of the windscreen and a 5° line, according to ECE R43, which is moved vertically downwards until meeting any point on the dashboard surface, and
- a point which is 165 mm rearward, on the windscreen surface, of the point of contact of a sphere of 165 mm diameter which also maintains contact with other parts of the vehicle front structure.

"Windscreen lower reference line (LWL)"

~~to be defined, see Figure 13c.~~ Definition to be proposed by EC.

3.3433. "Windscreen side reference line (SWL)" ~~is means~~ the trace of all points of intersection between the windscreen and a line which is perpendicular to the

transverse plane of the vehicle and maintains a lateral offset of 82.5 mm inside the A-pillars (see Figure 13b).

3.3534. "Windscreen rear reference line (RWL)" ~~is means~~ a line parallel to, and at a distance of 82.5 mm from, the windscreen header, measured on the windscreen surface (see Figure 13a).

3.3635. "Windscreen test area" means an area of the windscreen bordered as follows (see Figure 12):

(a) ~~towards the windscreen top,~~ by a line 82.5 mm forwards of the windscreen rear reference line, ~~as defined in paragraph 3.35.~~

(b) ~~towards each windscreen side,~~ by a line 82.5 mm inside ~~the each~~ windscreen side reference line, ~~as defined in paragraph 3.34.~~

(c) ~~towards the base of the windscreen,~~ by a line 82.5 mm inside rearward of the windscreen lower reference line, ~~as defined in paragraph 3.33.~~

~~(See Figure 12)~~

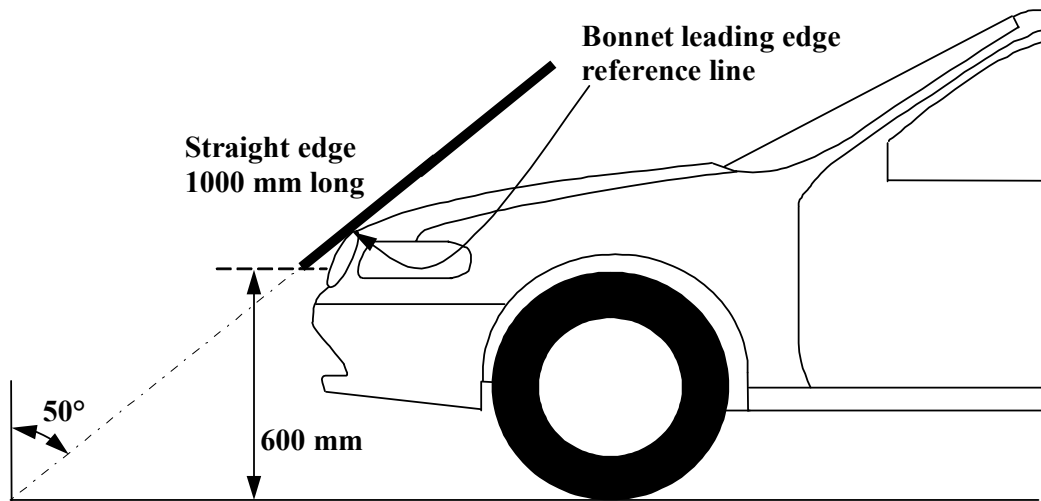

Figure 1: Bonnet Leading edge Reference Line. (see [§paragraph 3.6.](#))

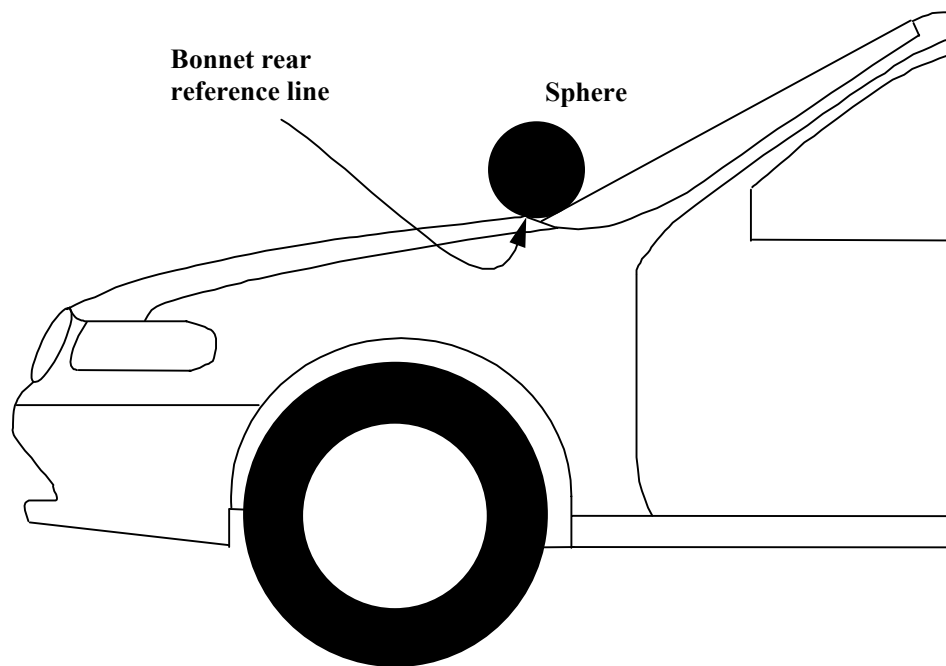

Figure 2: Bonnet Rear Reference Line. (see [§paragraph 3.7.](#))

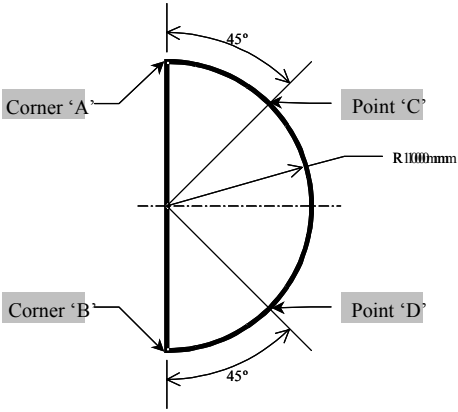

Figure 3: Template. (see §paragraph 3.7.)

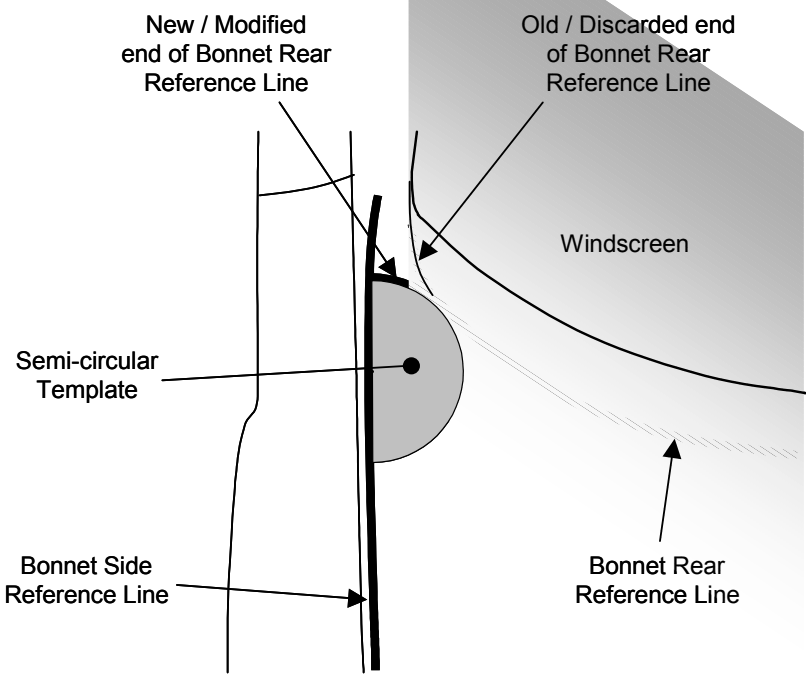

Figure 4: Marking of intersection between bonnet rear and side reference lines.  
(see paragraph §3.7.)



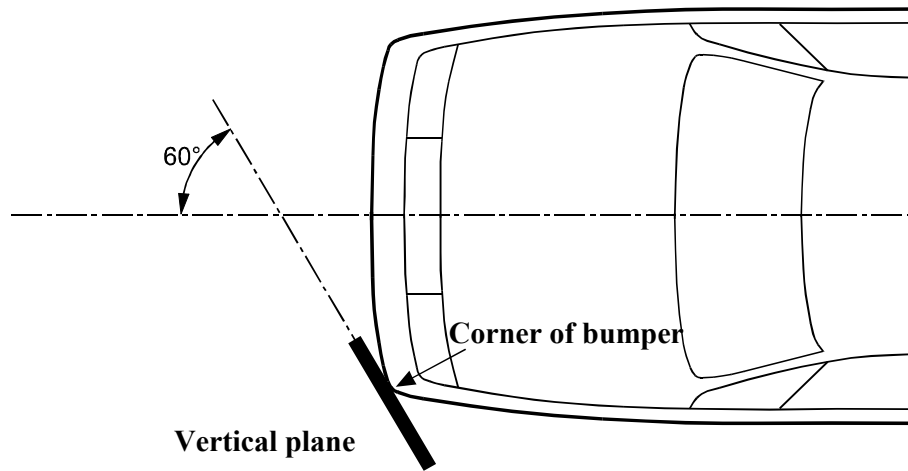

Figure 5: Corner of ~~Bumper~~ bumper (see paragraph §3.12.)

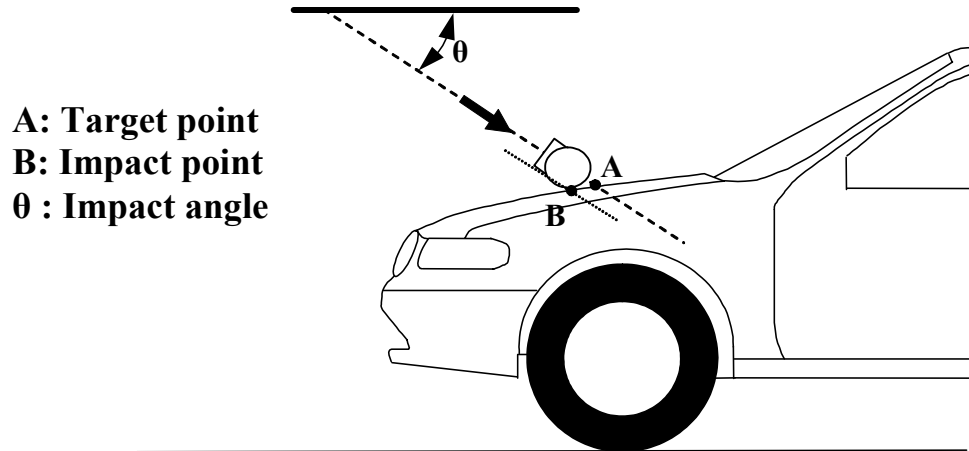

Figure 6: Impact and target ~~Pointpoint~~ Pointpoint. (insertion of impact angle example) (see paragraph §3.17. and paragraph §3.24.)

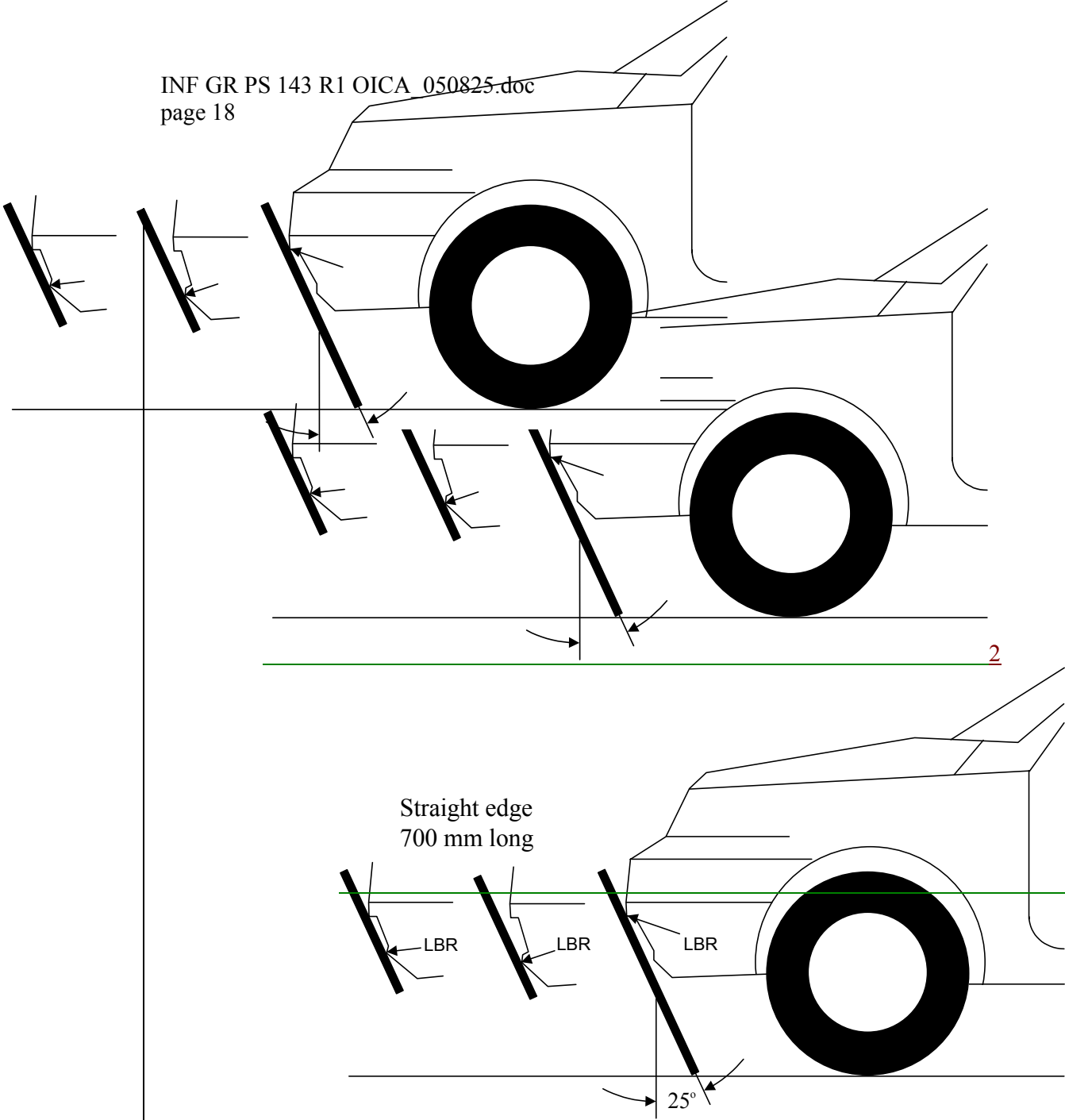

Figure 7: Lower Bumper Reference Line, LBRL. (see paragraph §3.19.)

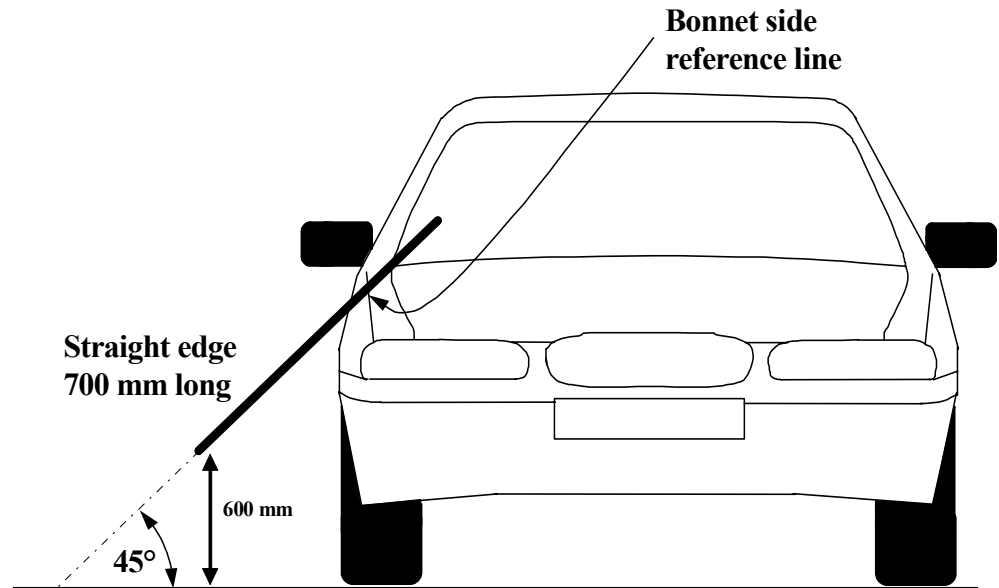
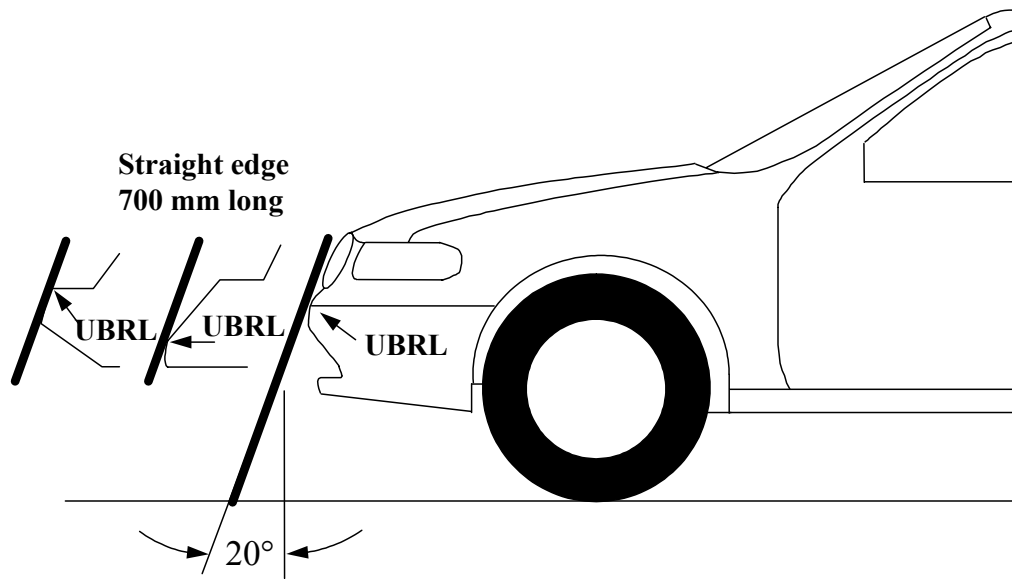
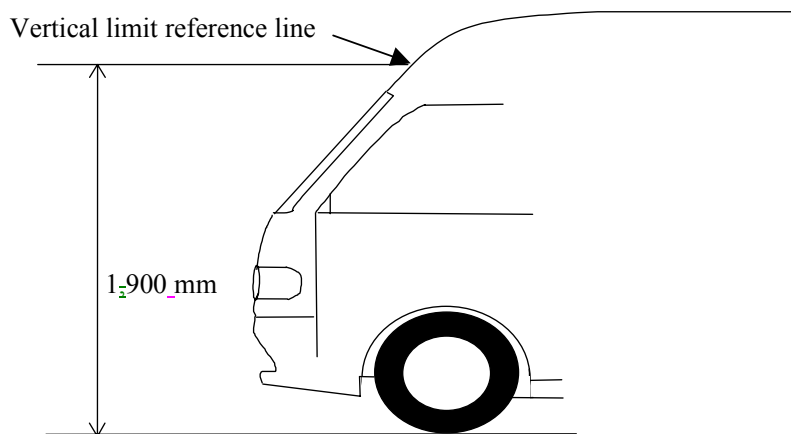

Figure 8: Side ~~Reference-reference~~ Lineline. (see paragraph §3.23.)



[Figure 9: Upper Bumper Reference Line, UBRL. (see paragraph §3.28.)]



[Figure 10: Vertical Limit Reference Line. (see paragraph §3.30.)]

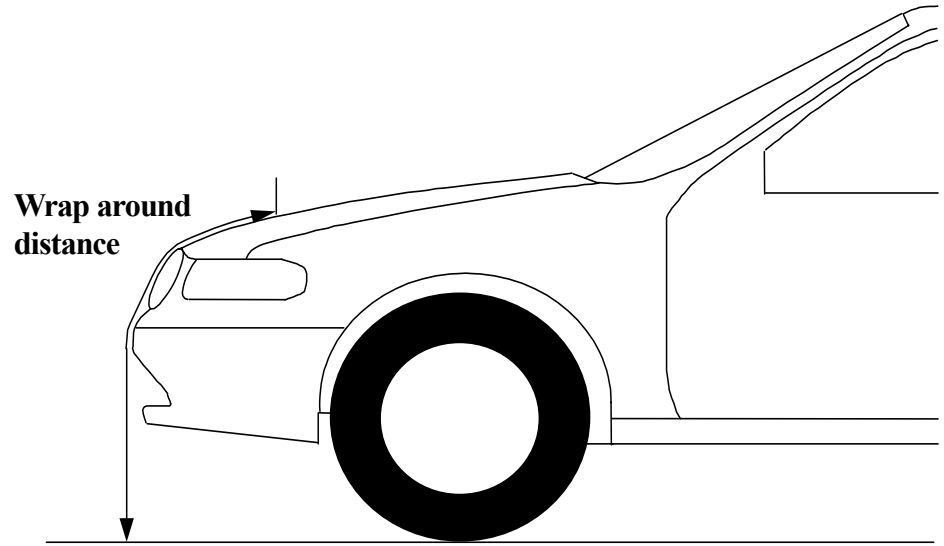

Figure 11: Wrap ~~Around-around Distance-distance Measurementmeasurement-~~ (see [paragraph §3.31.](#))

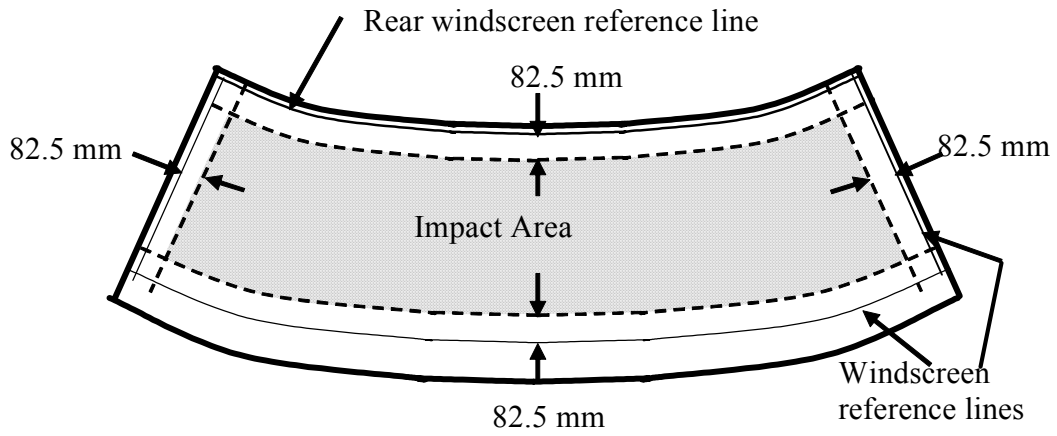

Figure 12: Windscreen test area- ([see paragraph §3.36.](#))

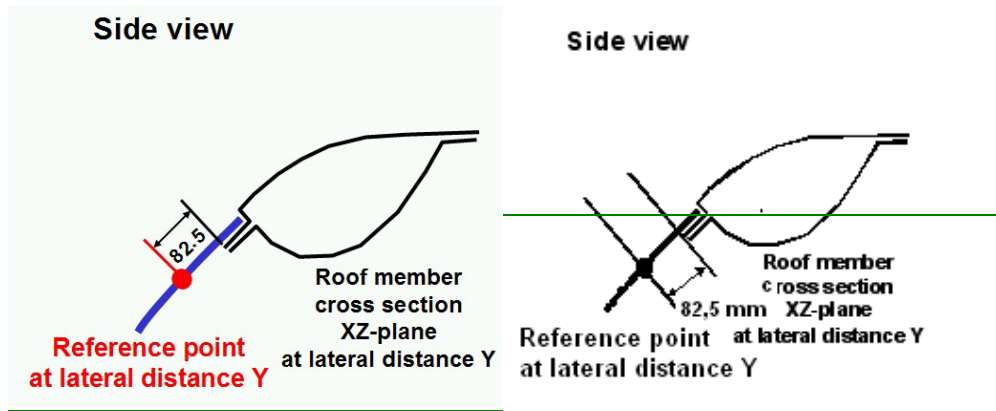

Figure 13a: Windscreen Rear-rear Reference-reference Line (see paragraph §3.35.)  
*This diagram needs to be changed to reflect definition.*

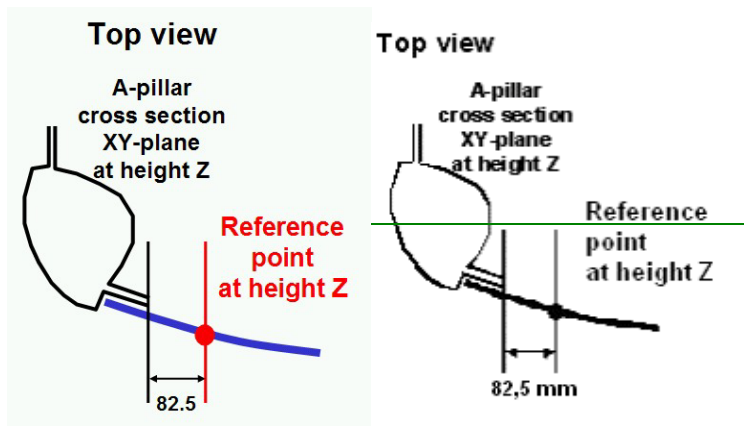

Figure 13b: Windscreen Side-side Reference-reference Line (see paragraph §3.34.)  
*This diagram needs to be changed to for measurement.*

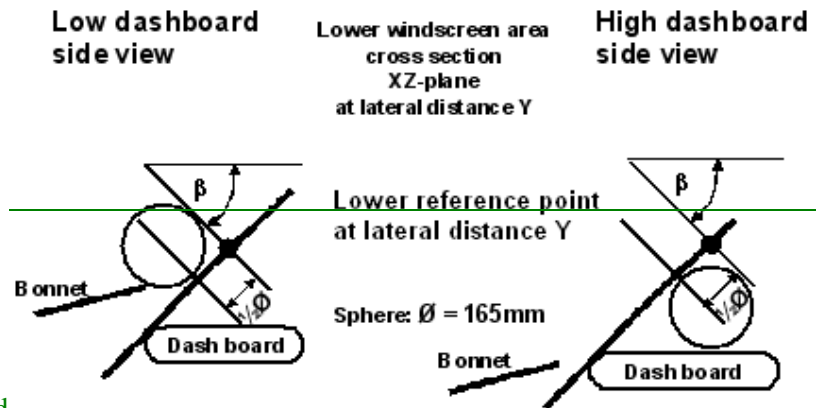

Figure to be created

Figure 13c: Windscreen Lower-lower Reference-reference Line (see §paragraph 3.33.)

————— *This diagram requires more discussion and agreement.*

|

4. GENERAL REQUIREMENTS-

This ~~Global~~ ~~global~~ ~~Technical~~ ~~technical~~ ~~Regulation~~ ~~regulation~~ specifies the following tests to verify compliance of vehicles.

4.1. Legform test to bumper:

For vehicles with a lower bumper height of less than 425mm the requirements of section 4.1.1. shall be applied.

For vehicles with a lower bumper height which is both greater than, or equal to, 425mm and less than 500mm the requirements of either section 4.1.1. or section 4.1.2., as agreed by the manufacturer, shall apply.

For vehicles with a lower bumper height of greater than 500mm the requirements of section 4.1.2. shall be applied.

One of the following legform tests are ~~will be~~ required to be performed:

4.1.1. Lower legform to bumper:

To ~~verify the compliance~~ ~~comply~~ with the performance requirements as specified in paragraph 5.1.1., both the test impactor specified in ~~section-paragraph~~ 6.3.1.1. and the test procedures specified in ~~paragraph section-~~7.1.1. shall be used

4.1.2. Upper legform to bumper:

To ~~verify the comply compliance~~ with the performance requirements as specified in ~~paragraphsection~~ 5.1.2., both the test impactor specified in ~~paragraphsection~~ 6.3.1.2. and the test procedures specified in ~~paragraphsection~~ 7.1.2. shall be used.

4.2. Child headform impact:

To ~~verify the compliance~~ ~~comply~~ with the performance requirements as specified in ~~paragraphssection~~ 5.2.1. and 5.2.3., both the test impactor specified in ~~paragraphsection~~ 6.3.2.1. and the test procedures specified in ~~paragraphssections~~ 7.2 and 7.3. shall be used.

4.3. Adult headform impact:

To ~~verify the compliance~~ ~~comply~~ with the performance requirements as specified in ~~paragraphssection~~ 5.2.2. and 5.2.3., both the test impactor specified in paragraph 6.3.2.2. and the test procedures specified in ~~paragraphsections~~ 7.2. and 7.4. shall be used.

~~4.4. All tests shall comply with the requirements of the general site conditions specified in ~~paragraphsection~~ 6.1. and vehicle preparation requirements specified in ~~paragraphsection~~ 6.2.~~

5. PERFORMANCE REQUIREMENTS-

5.1. Legform to Bumper:



- 5.1.1. When tested in accordance with [paragraphsection](#) 7.1.1. (lower legform to bumper), the maximum dynamic knee bending angle shall not exceed ~~[21.0°19°]~~, the maximum dynamic knee shearing displacement shall not exceed ~~[6.0 mm]~~, and the acceleration measured at the upper end of the tibia shall not exceed ~~[200-170 g]~~.

In addition the manufacturer may nominate bumper test widths up to 264mm in total where the acceleration measured at the upper end of the tibia shall not exceed 250g.

- 5.1.2. When tested in accordance with [paragraphsection](#) 7.1.2. (~~Upper-upper~~ legform to bumper), the instantaneous sum of the impact forces with respect to time shall not exceed ~~[7.56.25 kN]~~ and the bending moment on the test impactor shall not exceed ~~[510375 Nm]~~.

In addition the manufacturer may nominate bumper test widths up to 264mm in total where the instantaneous sum of the impact forces with respect to time shall not exceed 7.5 kN and the bending moment on the test impactor shall not exceed 510 Nm.

## 5.2. Headform tests

### 5.2.1. Child headform to front structure:

When tested in accordance with [paragraphsection](#) 7.3. ~~[for all tests, together with the tests according to paragraph 5.2.2.]~~ the HPC shall not exceed 1000 over ~~[2/3] of the bonnet test area and [1700] for the remaining [1/3] [of the bonnet test area].~~ the Head Injury Criterion (HIC) shall not exceed ~~[1,000] over the child headform test area which falls within the bonnet top.~~ comply with paragraph 5.2.3. For impact points in the windscreen test area, the requirements of paragraph 5.2.34. shall apply.

### 5.2.2. Adult headform to the front structure:

When tested in accordance with [paragraphsection](#) 7.4. ~~[for all tests, together with the tests according to paragraph 5.2.1.]~~ the HPC shall not exceed 1000 over ~~[2/3] of the bonnet test area and [1700] for the remaining [1/3] [of the bonnet test area].~~ the Head Injury Criterion (HIC) shall not exceed ~~[1,000] over the adult headform test area which falls within the bonnet top.~~ comply with paragraph 5.2.3. For impact points in the windscreen test area, the requirements of paragraph 5.2.34. shall apply.

- 5.2.3. The HPC recorded shall not exceed 1000 over one half of the Child headform test area and, in addition, shall not exceed 1000 over 2/3 of the combined Child and Adult headform test areas. The HPC for the remaining areas shall not exceed 1700 for both headforms.

### 5.2.4. Splitting of Headform test zone

5.2.4.1. The manufacturer shall identify the zones of the bonnet top where the Head Performance Criterion (HPC) must not exceed 1000 (HPC1000 Zone) respectively 2000 (HPC1700 Zone) (see Figure 13).

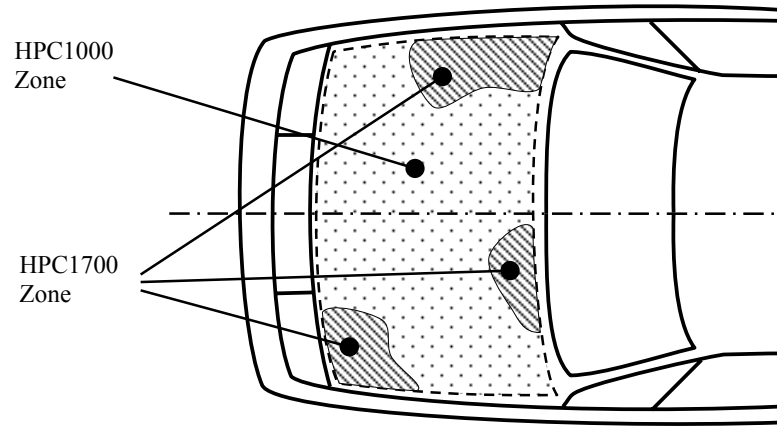

Figure 14

Marking of HPC1000 Zone and HPC1700 Zone

5.2.4.2. Marking of the “Bonnet Top” impact area as well as “HPC1000 Zone” and “HPC1700 Zone” will be based on a drawing supplied by the manufacturer, when viewed from a horizontal plane above the vehicle that is parallel to the vehicle ground reference level. A sufficient number of x and y co-ordinates shall be supplied by the manufacturer to mark up the areas on the actual vehicle while considering the vehicle outer contour in the z direction.

5.2.4.3. The areas of “HPC1000 Zone” and “HPC1700 Zone” may each consist of several parts, with the number of these parts not being limited.

5.2.4.4. The calculation of the surface of the impact area as well as the surface areas of “HPC1000 Zone” and “HPC1700 Zone” shall be done on the basis of a flat developed bonnet surface and on the basis of drawing data supplied by the manufacturer.

5.2.5. If the tested front structure as impacted by the child or adult headforms includes parts of the windscreen, as defined in paragraph 3.32, the Head Injury Criterion (HIC) shall not exceed [1,000] for all the any selected impact impact points within the windscreen test area, as defined in paragraph 3.36.

6. TEST SPECIFICATIONS

6.1. General Site test Conditionsconditions

6.1.1. Temperature and humidity

The ~~stabilized~~stabilised temperature of the test tools and of the vehicle or sub-system at the time of testing shall be  $\{20^{\circ} \pm 4^{\circ}\}$ C.

The relative humidity of ~~the test~~controlled storage area where all ~~equipment is test~~impactors are held~~stored~~ should be  $40\% \pm 30\%$  ~~{10 to 70} per cent~~ after a ~~stabilized~~stabilised period of at least four hours prior to ~~the application of~~removal for use in any test.

Each test shall be completed within two hours of when the impactor to be used is removed from the controlled storage area.

~~6.1.1.1. Sufficient time must be allowed before testing for the temperature of all vehicle components to stabilize to the required temperature range.~~

~~6.1.1.2.~~ Relative humidity and temperature of the test area shall be measured at the time of the test, and recorded in the test report.

6.1.2. Impact test site

The test site shall consist of a flat, smooth and hard surface with a slope not exceeding 1 per cent.

6.2. Preparation of the vehicle

6.2.1. Either a complete vehicle, or a cut-body, adjusted to the following conditions shall be used for the test.

6.2.1.1. The vehicle shall be in its normal ride attitude, ~~as described in paragraph 3.20.~~, and shall be either securely mounted on raised supports or at rest on a flat horizontal surface with the. ~~The parking brake shall be applied, or the cut body shall be securely mounted.~~

6.2.1.2. The cut-body shall include, in the test, all parts of the vehicle front structure ~~and~~, all under-bonnet components, ~~or~~ and all components behind the windscreen ~~components~~, that may be involved in a frontal impact with a vulnerable road user ~~in the test~~, to demonstrate the performance and interactions of all the contributory vehicle components.

~~6.2.1.2.1.~~ The cut-body shall be securely mounted in the normal vehicle ride attitude.

6.2.2. All devices designed to protect vulnerable road users when impacted by the vehicle shall be correctly activated before and/or be active during the appropriate test. An example of a typical procedure is as specified described in Annex 1. It shall be the

responsibility of the manufacturer to show that any devices will act as intended in a pedestrian impact.

~~6.2.3. Any vehicle component which could change shape or position, such as 'pop-up' headlights, other than active devices to protect pedestrians, shall be set to a shape or position that the test institutes in consultation with the manufacturer consider to be the most appropriate for these tests.~~

6.2.3. For vVehicle components which could change shape or position, other than active devices to protect pedestrians, where such devices and which have more than one fixed shape or position shall require the vehicle to comply with the component(s) in each fixed shape or position.~~the vehicle shall comply with all requirements for all of these positions.~~

Where such devices have only one fixed position, only the fixed position shall be considered.

6.2.4. If the vehicle is fitted with a badge, mascot or other structure which would bend back or retract under a low applied load, then such a load shall be applied before and/or while the test requirements are completed.

6.2.5. All standard equipment normally fitted to the front end of the vehicle shall be in position.

### 6.3. Test impactor specifications

6.3.1. Legform impactors:

6.3.1.1. Lower legform impactor:

The lower legform impactor shall consist of two ~~foam~~foam-covered rigid segments, representing femur (upper leg) and tibia (lower leg), joined by a deformable, simulated knee joint. The overall length of the impactor shall be  $926 \pm [5]$  mm, having a required test mass of  $13.4 \pm [0.2]$  kg (see Figure 14).

Brackets, pulleys, etc. attached to the impactor for the purpose of launching it, may extend the dimensions shown in Figure 14.

6.3.1.1.1. The diameter of the femur and tibia shall be  $70 \pm 1$  mm and both shall be covered by foam ~~'flesh'~~ and skin. The foam flesh shall be 25 mm thick Confor™ foam type CF-45 or equivalent. The skin shall be made of neoprene foam, faced with  $0.5$  mm thick nylon cloth both sides, with an overall thickness of 6 mm.

6.3.1.1.2. The ~~'centre of the knee'~~ is defined as the point about which the knee effectively bends.

6.3.1.1.3. The knee joint shall be fitted with deformable knee elements from the same batch as those used in the certification tests.

6.3.1.1.4. The "femur" is defined as all components or parts of components (including flesh,

skin covering, damper, instrumentation and brackets, pulleys, etc. attached to the impactor for the purpose of launching it) above the level of the centre of the knee.

- 6.3.1.1.5. The "tibia" is defined as all components or parts of components (including flesh, skin covering, instrumentation and brackets, pulleys, etc. attached to the impactor for the purpose of launching it) below the level of the centre of the knee. Note that the tibia as defined includes allowances for the mass, etc., of the foot.
- 6.3.1.1.6. The total masses of the femur and tibia shall be  $8.6 \pm \{0.1\}$  kg and  $4.8 \pm \{0.1\}$  kg respectively, and the total mass of the impactor shall be  $13.4 \pm \{0.2\}$  kg. The centre of gravity of the femur and tibia shall be  $217 \pm \{10\}$  mm and  $233 \pm \{10\}$  mm from the centre of the knee respectively. The moment of inertia of the femur and tibia, about a horizontal axis through the respective centre of gravity and perpendicular to the direction of impact, shall be  $0.127 \pm \{0.010\}$  kgm<sup>2</sup> and  $0.120 \pm \{0.010\}$  kgm<sup>2</sup> respectively.
- 6.3.1.1.7. The impactor shall be fitted with foam flesh cut from one of up to four consecutive sheets of Confor™ foam flesh material or equivalent, produced from the same batch of manufacture (cut from one block or 'bun' of foam), provided that foam from one of these sheets was used in the dynamic certification test and the individual weights of these sheets are within  $\pm 2$  per cent of the weight of the sheet used in the certification test.
- 6.3.1.1.8. Lower legform instrumentation
- 6.3.1.1.8.1. A uniaxial accelerometer shall be mounted on the non-impacted side of the tibia,  $66 \pm 5$  mm below the knee joint centre, with its sensitive axis in the direction of impact.
- ~~6.3.1.1.8.2. The impactor shall be instrumented to measure the bending angle and the shearing displacement between femur and tibia.~~
- 6.3.1.1.8.32. A damper shall be fitted to the shear displacement system and may be mounted at any point on the rear face of the impactor or internally. The damper properties shall be such that the impactor meets both the static and dynamic shear displacement requirements and prevents excessive vibrations of the shear displacement system.
- 6.3.1.1.8.43. Transducers shall be fitted to measure knee bending angle and knee shearing displacement.
- 6.3.1.1.8.54. The instrumentation response value CFC, as defined in ISO 6487:2002, shall be 180 for all transducers. The CAC response values, as defined in ISO 6487:2002, shall be 50° for the knee bending angle, 10 mm for the shearing displacement and 500 g for the acceleration. This does not require that the impactor itself be able to physically bend and shear to these angles and displacements.

6.3.1.1.9. Lower legform certification

6.3.1.1.9.1. The lower legform impactor shall meet the performance requirements specified in ~~paragraph~~section 8.

6.3.1.1.9.2. The certified impactor may be used for a maximum of 20 impacts before re-certification. With each test new plastically deformable knee elements should be used. The impactor shall also be re-certified if more than one year has elapsed since the previous certification ~~or~~ if any impactor transducer output, in any impact, has exceeded the specified CAC or has reached the mechanical limits of the leg impactor deformation capability.

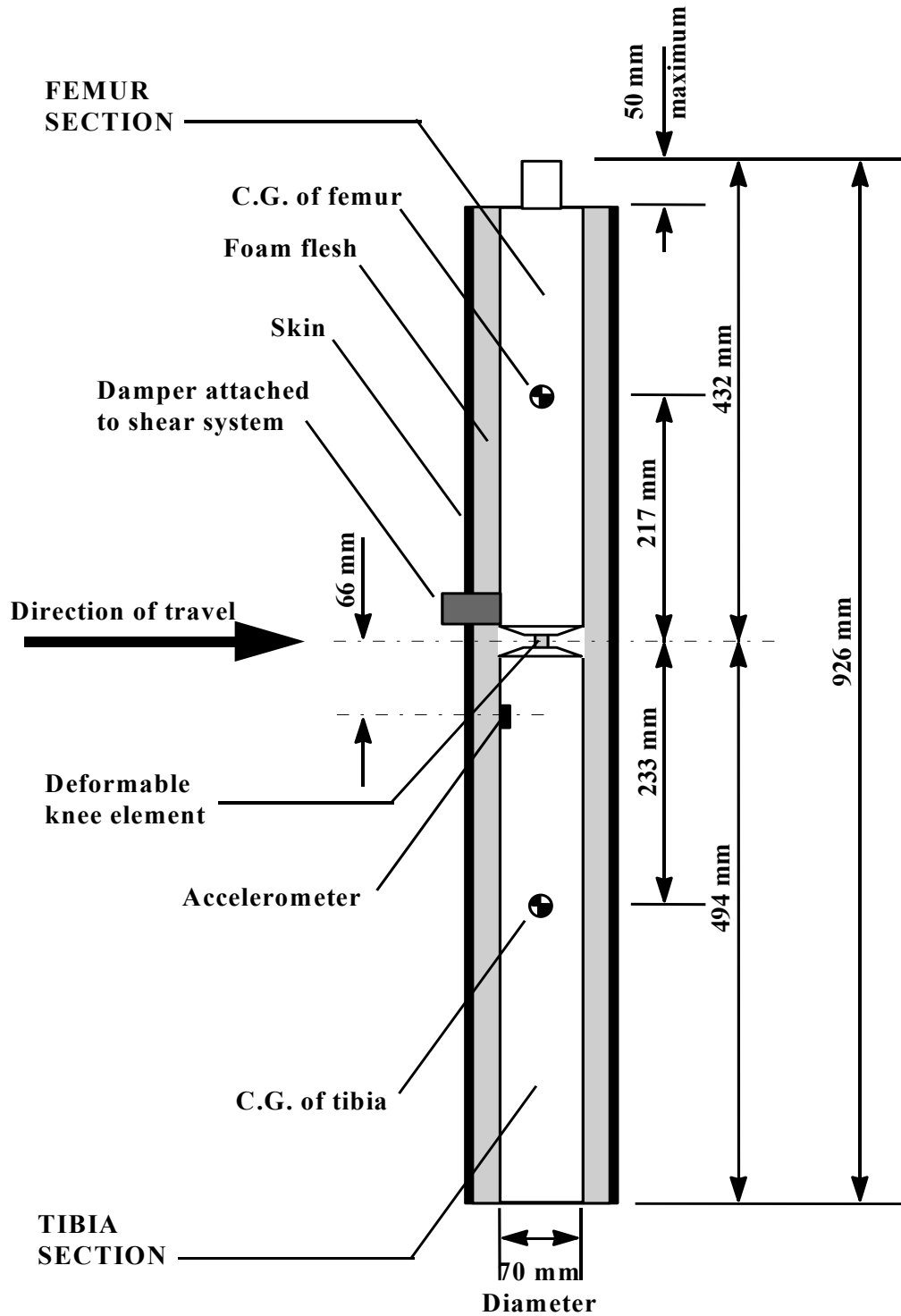

Figure 4415: Lower legform impactor. (see §paragraph 6.3.1.1.)

6.3.1.2. Upper legform impactor:

The upper legform impactor shall be rigid, foam covered at the impact side, and  $350 \pm 5$  mm long (see Figure 15).

- 6.3.1.2.1. The total mass of the upper legform impactor including those propulsion and guidance components which are effectively part of the impactor during the impact shall be  $9.5 \text{ kg} \pm 0.1 \text{ kg}$ . ~~The upper legform impactor mass may be adjusted from this value by up to  $\pm 1 \text{ kg}$ , provided the required impact velocity is also changed using the formula:~~

$$V = \sqrt{(1.170/M)} \sqrt{1.170/M}$$

~~Where:~~

~~V = impact velocity (m/s)~~

~~M = mass (kg), measured to an accuracy of better than  $\pm 1$  per cent]~~

~~The above highlighted section should be removed as the mass will not change for this test.~~

- 6.3.1.2.2. The total mass of the front member and other components in front of the load transducer assemblies, together with those parts of the load transducer assemblies in front of the active elements, but excluding the foam and skin, shall be  $1.95 \pm 0.05 \text{ kg}$ .

6.3.1.2.3. The upper legform impactor for the bumper test shall be mounted to the propulsion system, by a torque-limiting joint, to prevent large off centre loads damaging the guidance system. The guidance system shall be fitted with low friction guides, insensitive to off-axis loading, that allow the impactor to move only in the specified direction of impact, when in contact with the vehicle. The guides shall prevent motion in other directions including rotation about any axis.

6.3.1.2.34. The torque limiting joint shall be set so that the longitudinal axis of the front member is perpendicular to the axis of the guidance system, with a tolerance of  $\pm 2^\circ$ , with the joint friction torque set to ~~a minimum of  $650\text{--}675 \text{ Nm}$~~   $\pm 25 \text{ Nm}$ .

6.3.1.2.45. The centre of gravity of those parts of the impactor which are effectively forward of the torque limiting joint, including any weights fitted, shall lie on the longitudinal centre line of the impactor, with a tolerance of  $\pm 10 \text{ mm}$ .

6.3.1.2.56. The length between the load transducer centre lines shall be  $310 \pm 1 \text{ mm}$  and the front member diameter shall be  $50 \pm 1 \text{ mm}$ .

6.3.1.2.67. The foam flesh shall be two sheets of  $25 \text{ mm}$  thick Confor™ foam type CF-45 or equivalent, and shall be cut from the sheet of material used for the dynamic certification test. The skin shall be a  $1.5 \text{ mm}$  thick fibre reinforced rubber sheet.



The foam and rubber skin together shall weigh  $0.6 \pm 0.1$  kg (this excludes any reinforcement, mountings, etc. which are used to attach the rear edges of the rubber skin to the rear member). The foam and rubber skin shall be folded back towards the rear, with the rubber skin attached via spacers to the rear member so that the sides of the rubber skin are held parallel. The foam shall be of such a size and shape that an adequate gap is maintained between the foam and components behind the front member, to avoid significant load paths between the foam and these components.

6.3.1.2.78. Upper legform instrumentation

6.3.1.2.78.1. The front member shall be strain gauged to measure bending moments in three positions, as shown in Figure 15, each using a separate channel. The strain gauges are located on the impactor on the back of the front member. The two outer strain gauges are located  $50 \pm 1$  mm from the impactor's symmetrical axis. The middle strain gauge is located on the symmetrical axis with a  $\pm 1$  mm tolerance.

6.3.1.2.78.2. Two load transducers shall be fitted to measure individually the forces applied at either end of the upper legform impactor, plus strain gauges measuring bending moments at the centre of the upper legform impactor and at positions 50 mm either side of the centre line, (see Figure 15).

6.3.1.2.78.3. The instrumentation response value CFC, as defined in ISO 6487:2002, shall be 180 for all transducers. The CAC response values, as defined in ISO 6487:2002, shall be 10 kN for the force transducers and  $\pm 1_000$  Nm for the bending moment measurements.

6.3.1.2.89. Upper legform certification

6.3.1.2.89.1. The upper legform impactor shall meet the performance requirements specified in [paragraphsection 8](#).

6.3.1.2.89.2. The certified impactor may be used for a maximum of 20 impacts before re-certification (this limit does not apply to propulsion or guidance components). The impactor shall also be re-certified if more than one year has elapsed since the previous certification or if any impactor transducer output, in any impact, has exceeded the specified CAC.

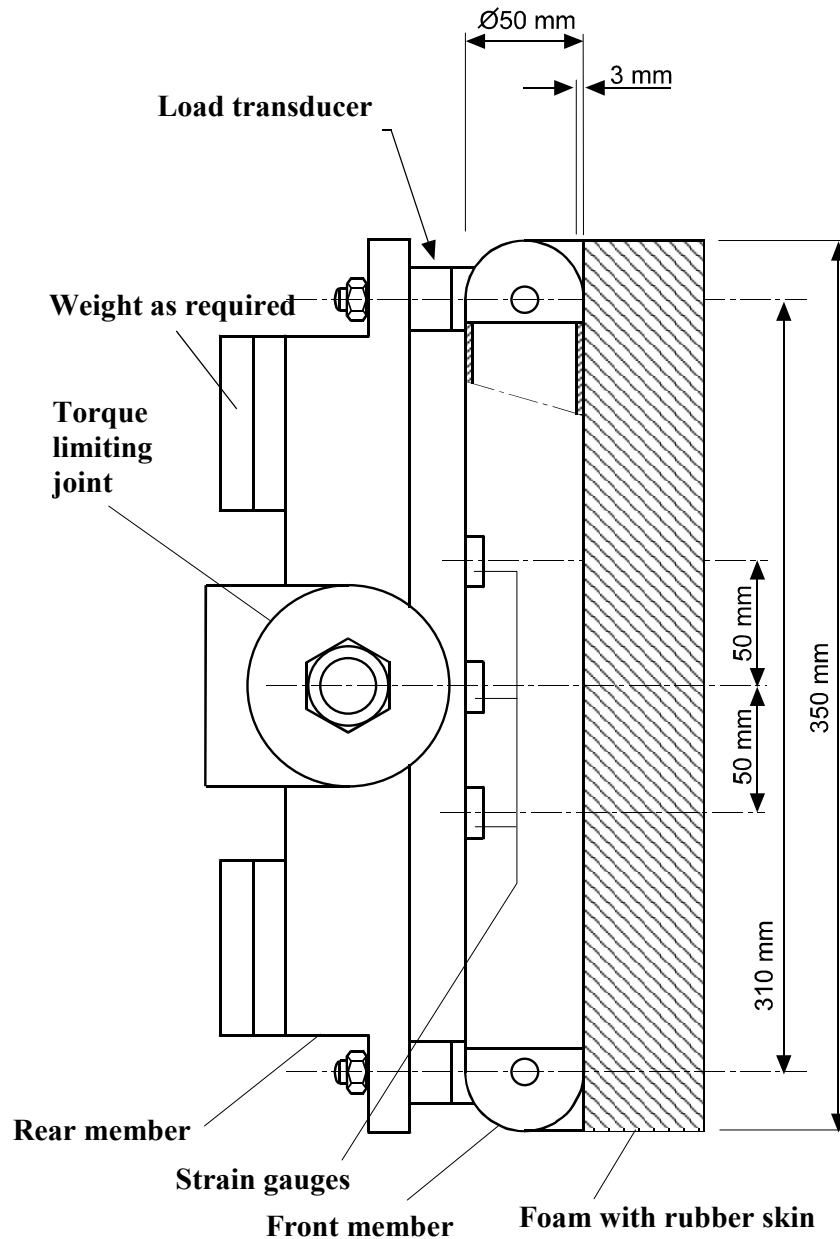

Figure 15: Upper legform impactor (see §paragraph 6.3.1.2.)

6.3.2. Child and ~~Adult-adult~~ headform impactors

6.3.2.1. Child headform impactor (see Figure 16)

The child headform impactor shall be made of aluminium, be of homogenous construction and be of spherical shape. The overall diameter shall be  $165 \pm 1$  mm. The mass shall be  $3.5 \pm 0.07$  kg. The moment of inertia about an axis through the centre of gravity and perpendicular to the direction of impact shall be within the

range of ~~[0.0080 to 0.01200-0.0075 to 0.0200-]~~  $\text{kgm}^2$ . The centre of gravity of the headform impactor including instrumentation shall be located in the geometric centre of the sphere with a tolerance of  $\pm$  ~~[52]~~ mm.

The sphere shall be covered with a  $14 \pm 0.5$  mm thick synthetic skin, which shall cover at least half of the sphere.

#### 6.3.2.1.1. Child headform instrumentation

A recess in the sphere shall allow for mounting one triaxial or three uniaxial accelerometers within  $\pm$  ~~[30]~~ 10 mm seismic mass location tolerance from the centre of the sphere for the measurement axis, and  $\pm$  1 mm seismic mass location tolerance from the centre of the sphere for the perpendicular direction to the measurement axis.

If three uniaxial accelerometers are used, one of the accelerometers shall have its sensitive axis perpendicular to the mounting face A (see figure 16) and its seismic mass shall be positioned within a cylindrical tolerance field of 1 mm radius and ~~[20]~~ mm length. The centre line of the tolerance field shall run perpendicular to the mounting face and its mid-point shall coincide with the centre of the sphere of the headform impactor.

The remaining accelerometers shall have their sensitive axes perpendicular to each other and parallel to the mounting face A and their seismic mass shall be positioned within a spherical tolerance field of 10 mm radius. The centre of the tolerance field shall coincide with the centre of the sphere of the headform impactor.

The instrumentation response value CFC, as defined in ISO 6487: 2002, shall be 1.000. The CAC response value, as defined in ISO 6487: 2002, shall be 500 g for the acceleration.

#### 6.3.2.1.3-2. First natural frequency

The first natural frequency of the headform impactor shall be over 5.000 Hz.

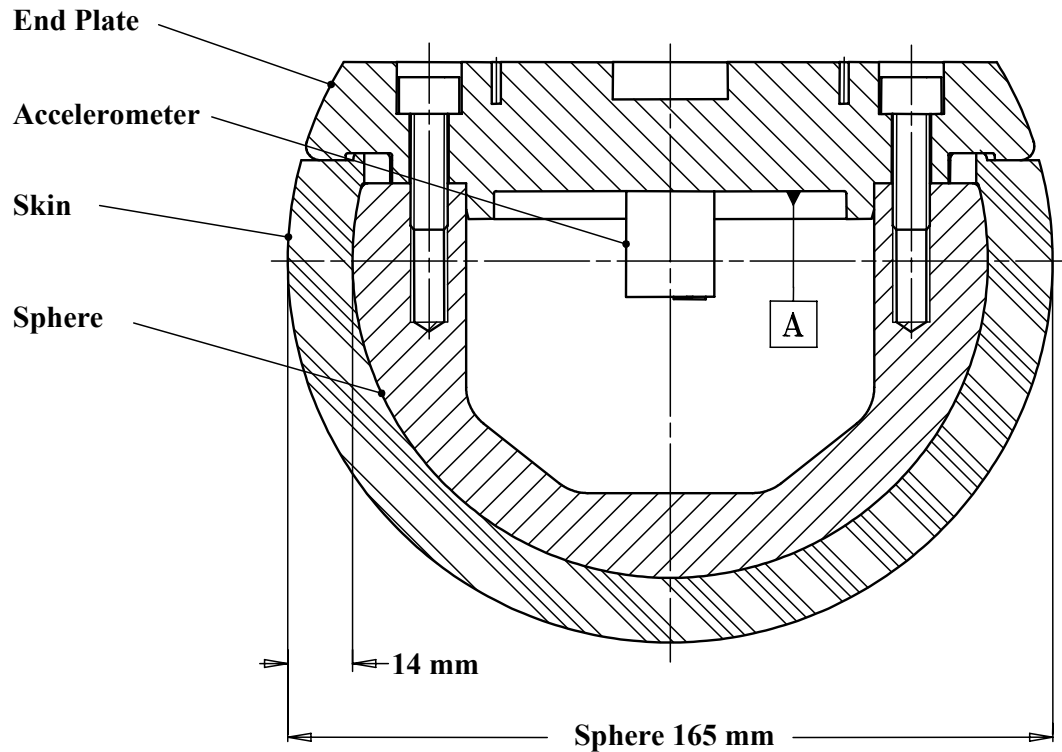

Figure 16: Child headform impactor (see §paragraph 6.3.2.1.)

~~6.3.2.1.4 The child headform test procedures are detailed in paragraph 7.2 below. Remove~~

6.3.2.2. Adult headform impactor (see Figure 17)

The adult headform impactor shall be made of aluminium, be of homogenous construction and be of spherical shape. The overall diameter is  $165 \pm 1$  mm as shown in Figure 17. The mass shall be  $[4.5 \pm 0.1]$  kg. The moment of inertia about an axis through the centre of gravity and perpendicular to the direction of impact shall be with in the rage of  $[0.0075$  to  $0.0200]$   $\text{kgm}^2$ . The centre of gravity of the headform impactor including instrumentation shall be located in the geometric centre of the sphere with a tolerance of  $\pm [5]$  mm.

The sphere shall be covered with a  $14 \pm 0.5$  mm thick synthetic skin, which shall cover at least half of the sphere.

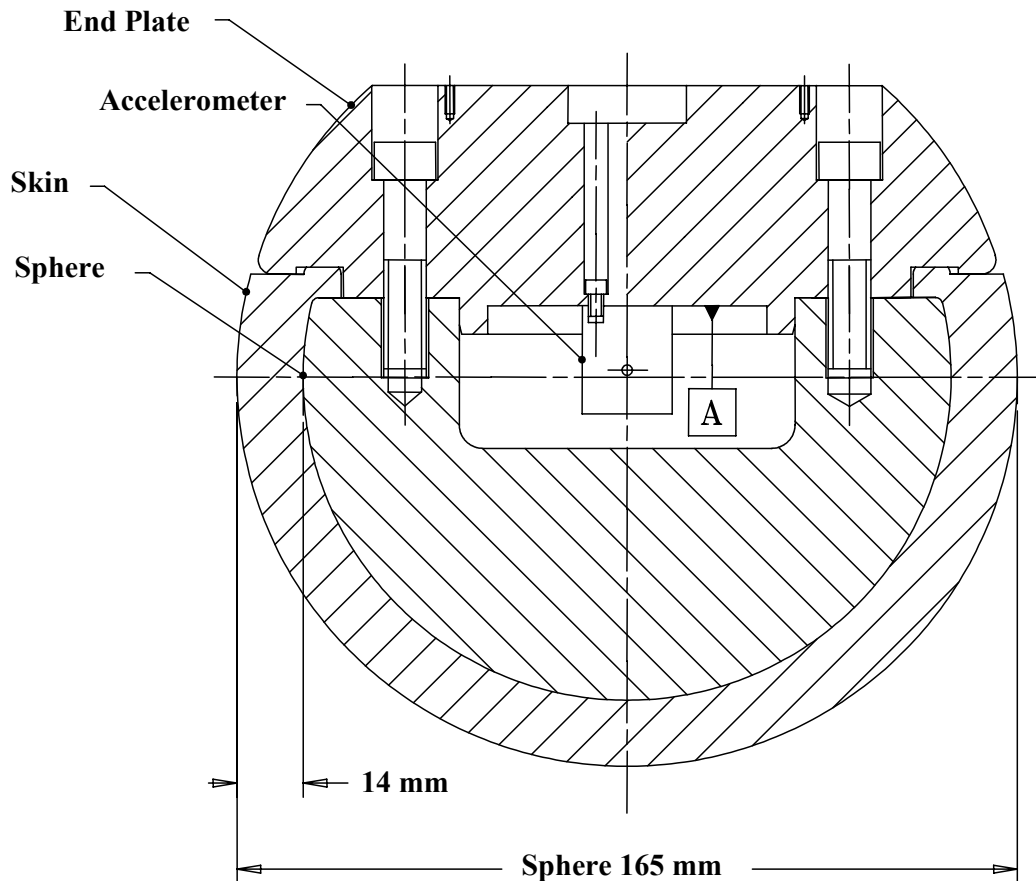

Figure 17: Adult headform impactor (see [§paragraph 6.3.2.2](#))

#### 6.3.2.2.1. Adult headform instrumentation

A recess in the sphere shall allow for mounting one triaxial or three uniaxial accelerometers within  $\pm [30\ 10]$  mm seismic mass location tolerance from the centre of the sphere for the measurement axis, and  $\pm [1]$  mm seismic mass location tolerance from the centre of the sphere for the perpendicular direction to the measurement axis.

If three uniaxial accelerometers are used, one of the accelerometers shall have its sensitive axis perpendicular to the mounting face A (see figure 17) and its seismic mass shall be positioned within a cylindrical tolerance field of 1 mm radius and 20 mm length. The centre line of the tolerance field shall run perpendicular to the mounting face and its mid-point shall coincide with the centre of the sphere of the headform impactor.

The remaining accelerometers shall have their sensitive axes perpendicular to each other and parallel to the mounting face A and their seismic mass shall be positioned within a spherical tolerance field of 10 mm radius. The centre of the tolerance field shall coincide with the centre of the sphere of the headform impactor.

The instrumentation response value CFC, as defined in ISO 6487: 2002, shall be 1<sub>2</sub>.000. The CAC response value, as defined in ISO 6487: 2002, shall be 500 g for the acceleration.

6.3.2.2.2. First natural frequency

First natural frequency of the headform impactors shall be over 5<sub>0</sub>.000 Hz.

6.3.2.3. Rear face of the headform impactors

A rear flat face shall be provided on the outer surface of the headform impactors which is perpendicular to the direction of travel, and typically perpendicular to the axis of one of the accelerometers as well as being a flat plate capable of providing for access to the accelerometers and an attachment point for the propulsion system.

6.3.2.4. Certification of the headform impactors

The headform impactors shall meet the performance requirements specified in [paragraph section 8](#). The certified impactors may be used for a maximum of 20 impacts before re-certification. The impactors shall be re-certified if more than one year has elapsed since the previous certification or if the transducer output, in any impact, has exceeded the specified CAC.

7. TEST PROCEDURES

[\[Refer to Annex 2 for impactor handling procedures\]](#)

7.1. [Legform to Bumper Test Procedures](#)  
[Refer to Annex 2 for impactor handling procedures](#)

7.1.1. Lower legform to bumper test procedure:

~~A minimum of three lower legform to bumper tests shall be carried out, one each to the middle and the outer thirds of the bumper at positions judged to be the most likely to cause injury. Tests shall be to different types of structure, where they vary throughout the area to be assessed. The selected test target points shall be in the bumper test area as defined in paragraph 3.22 [and shall be a minimum of 132 mm apart, and a minimum of 66 mm inside the defined corners of the bumper]. These minimum distances are is to be set with a flexible tape held tautly along the outer surface of the vehicle]. The positions tested by the laboratories shall be indicated in the test report.~~

~~7.1.1.1.1. Manufacturers might apply for derogation concerning an exemption zone for a removable towing hook.~~

7.1.1.2. The direction of the impact velocity vector shall be in the horizontal plane and parallel to the longitudinal vertical plane of the vehicle. The tolerance for the direction of the velocity vector in the horizontal plane and in the longitudinal plane shall be  $\pm 2^\circ$  at the time of first contact. The axis of the impactor shall be perpendicular to the horizontal plane with a tolerance of  $\pm 2^\circ$  in the lateral and longitudinal plane. The horizontal, longitudinal and lateral planes are orthogonal to each other (see Figure 18).

7.1.1.3. The bottom of the impactor shall be at 25 mm above ground reference level at the time of first contact with the bumper (see Figure 19), with a  $\pm 10$  mm tolerance. When setting the height of the propulsion system, an allowance must be made for the influence of gravity during the period of free flight of the impactor.

7.1.1.3.1. The lower legform impactor for the bumper tests shall be in 'free flight' at the moment of impact. The impactor shall be released to free flight at such a distance from the vehicle that the test results are not influenced by contact of the impactor with the propulsion system during rebound of the impactor.

The impactor may be propelled by an air, spring or hydraulic gun, or by other means that can be shown to give the same result.

7.1.1.3.2. At the time of first contact the impactor shall have the intended orientation about its vertical axis, for the correct operation of its knee joint, with a tolerance of  $\pm 5^\circ$  (see Figure 18).

7.1.1.3.3. At the time of first contact the centre line of the impactor shall be within a  $\pm 10$  mm tolerance to the selected impact location.

7.1.1.3.4. During contact between the impactor and the vehicle, the impactor shall not contact the ground or any object which is not part of the vehicle.

7.1.1.4. The impact velocity of the impactor when striking the bumper shall be  $11.1 \pm 0.2$  m/s. The effect of gravity shall be taken into account when the impact velocity is obtained from measurements taken before the time of first contact.

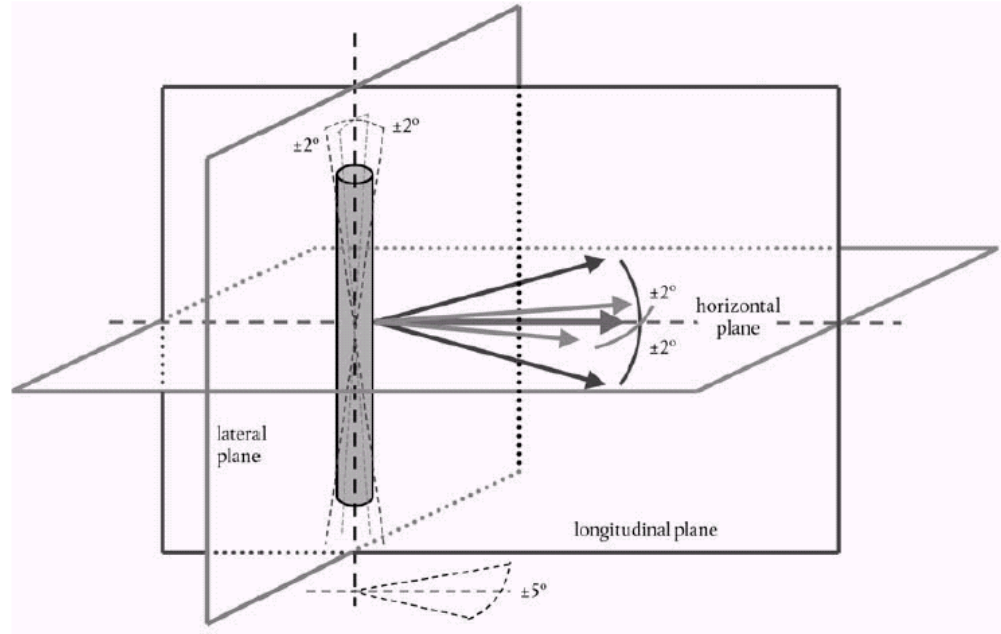

Figure 18: Tolerances of angles for the lower legform impactor at the time of first impact (see [§paragraph 7.1.1.3.2.](#))

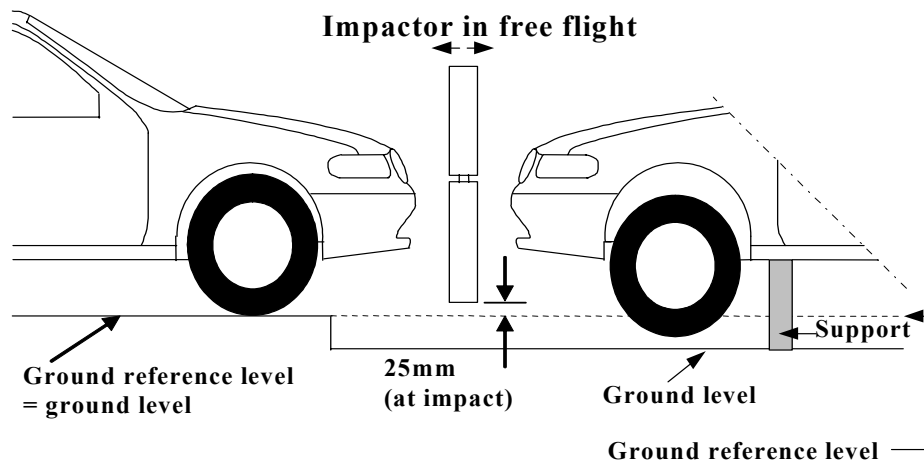

Figure 19: Lower legform to bumper tests for complete vehicle in normal ride attitude (left) and for cut-body mounted on supports (right) (see [§paragraph 7.1.1.3](#))



7.1.2. Upper legform to bumper test procedure:

7.1.2.1. ~~[If the lower bumper height at the test position is more than 500 mm and the manufacturer elects to perform an upper legform test instead of a lower legform test], a minimum of three lower upper legform to bumper tests shall be carried out, one each to the middle and the outer thirds of the bumper at positions judged to be the most likely to cause injury. Tests~~ The selected target points shall be in the bumper test area as defined in paragraph 3.22 and shall be a minimum of 132 mm apart. The minimum distance is to be set with a flexible tape held tautly along the outer surface of the vehicle. ~~The positions tested shall be indicated in the test report.~~

~~tests shall be to different types of structure, where they vary throughout the area to be assessed. The selected test points shall be a minimum of 132 mm apart, and a minimum of 66 mm inside the defined corners of the bumper. These minimum distances are to be set with a flexible tape held tautly along the outer surface of the vehicle. The positions tested by the laboratories shall be indicated in the test report.~~

~~7.1.2.1.1. Manufacturers might apply for derogation concerning an exemption zone for a removable towing hook.~~

7.1.2.2. The direction of impact shall be parallel to the longitudinal axis of the vehicle, with the axis of the upper legform vertical at the time of first contact. The tolerance to this direction is  $\pm \{2\}^\circ$ .

~~7.1.2.2.1.~~ At the time of first contact the impactor centre line shall be vertically midway between the upper bumper reference line and the lower bumper reference line with a  $\pm 10$  mm tolerance and laterally with the selected impact location with a tolerance of  $\pm 10$  mm.

7.1.2.3. The impact velocity of the upper legform impactor when striking the bumper shall be  $11.1 \pm \{0.2\}$  m/s.

## 7.2. Headform Test Procedures

7.2.1. Propulsion of the headform impactors

The headform impactors shall be in "free flight" at the moment of impact, at the required impact velocity (see paragraphs 7.3.5. and 7.4.5.) and the required direction of impact (see paragraphssections 7.3.6. and 7.4.6.).

The impactors shall be released to free flight at such a distance from the vehicle that the test results are not influenced by contact of the impactor with the propulsion system during rebound of the impactor.

7.2.2. Measurement of impact velocity

The velocity of the headform impactor shall be measured at some point during the free flight before impact, in accordance with the method specified in

ISO 3784:-1976 (ISO number to be checked). The accuracy of velocity measurement shall be  $\pm 0.01$  m/sec. The measured velocity shall be adjusted considering all factors which may affect the impactor between the point of measurement and the point of impact, in order to give the velocity of the impactor at the time of impact. The angle of the velocity vector at the time of impact shall be calculated or measured.

### 7.2.3. Recording

The acceleration time histories shall be recorded, and HIC shall be calculated. The first point of contact on the front structure of the vehicle shall be recorded. Recording of test results shall be in accordance with ISO 6487:2002.

### 7.2.4 “Bonnet Top Zone A” and “Bonnet Top Zone B”

7.2.4.1 The manufacturer shall identify the zones of the bonnet top where the Head Performance Criterion (HPC) must not exceed 1000 (Bonnet Top Zone A) respectively [1700] (Bonnet Top Zone B), according to the technical requirements set out in paragraph 5.2 (see Figure 20).

Figure 20

Bonnet Top Zone A and Bonnet Top Zone B

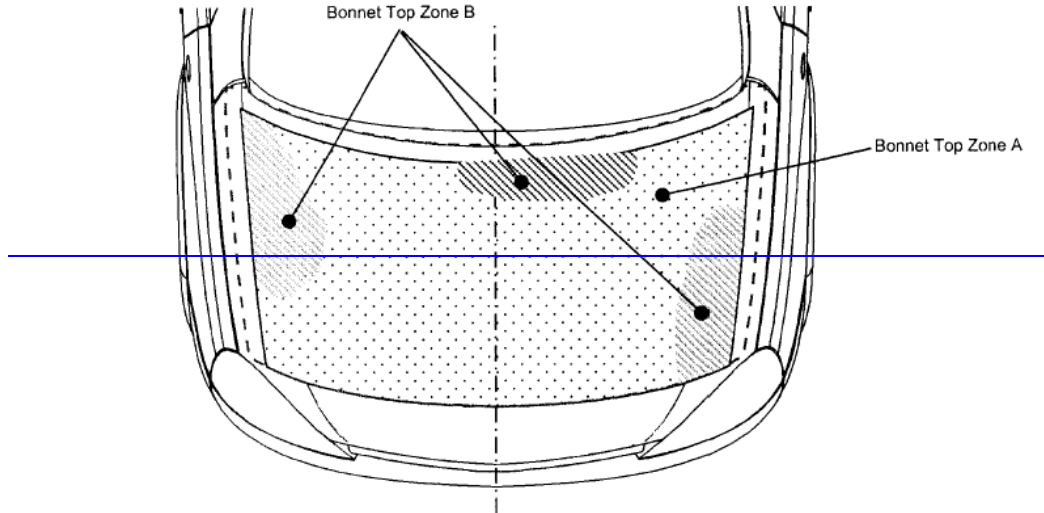

7.2.4.2 Marking of the “Bonnet Top” impact area as well as “Bonnet Top Zone A” and “Bonnet Top Zone B” will be based on a drawing supplied by the manufacturer, when viewed from a horizontal plane above the vehicle that is parallel to the vehicle horizontal zero plane. A sufficient number of x and y co-ordinates shall be supplied by the manufacturer to mark up the areas on the actual vehicle while considering the vehicle outer contour in the z direction.

~~7.2.4.3~~ ~~The areas of “Bonnet Top Zone A” and “Bonnet Top Zone B” may consist of several parts, with the number of these parts not being limited.~~

~~7.2.4.4~~ ~~The calculation of the surface of the impact area as well as the surface areas of “Bonnet Top Zone A” and “Bonnet Top Zone B” shall be done on the basis of a projected bonnet when viewed from a horizontal plane parallel to the horizontal zero plane above the vehicle, on the basis of the drawing data supplied by the manufacturer.~~

~~7.2.5~~ ~~[specify min time in between tests]~~

7.3. Child headform Test test Procedureprocedure:

This test procedure is applicable with respect to the requirements of paragraph 5.2.1. and 5.2.3. of this Regulationtr.

7.3.1. Tests shall be made to the front structure within the boundaries as defined in paragraph 3.11. For tests on the rear area of the bonnet top, the headform impactor shall not contact the windscreen or A-pillar before impacting the bonnet top.

~~7.3.2.~~ ~~[A minimum of [eighteen 9] tests shall be carried out with the child headform impactor, [six 3] tests each to the middle and the outer thirds of the bonnet top, as described in paragraph 3.25, at positions judged to be the most likely to cause injury. Tests shall be to different types of structure, where these vary throughout the area to be assessed.]~~

7.3.3~~2~~. ~~The~~ No test impact points shall be located so that the impactor ~~is~~ will not expected to impact the test area with a glancing blow resulting in a more severe second impact.

~~The~~ Sselected test impact pointss on the bonnet for the child headform impactor shall, at the time of first contact:

– be a minimum of 165 mm apart, and

~~be a minimum of 165 mm apart,~~

– be a minimum of 82,5 mm inside the defined bonnet side reference lines, as defined in paragraph 3.23, and-

– be forward of the WAD1700 line as defined in paragraph 3.31, or a minimum of 82,5 mm forwards of the bonnet rear reference line, as defined in paragraph 3.23.7, whichever is most forward at the point of measurement.-

~~[specify min time in between tests]~~

- be rearward of the WAD1000 line or, \_\_\_\_\_ Each selected test point for the child headform shall also be a minimum of 165-82,5 mm rearwards of the bonnet leading edge reference line, whichever is the most rearward at the point of measurement, as defined in paragraph 3.6.

If the WAD1700 line is located, at any point, in the windscreen test area, as defined in paragraph 3.36, at any point, [2] impact points selected test points on the windscreen test area for the child headform impactor shall, at time of first contact:

~~be a minimum of 165 mm apart,~~

- be forward of the WAD1700 line or a minimum of 82.5 mm forwards of the windscreen rear reference line, as defined in paragraph 3.35, or forwards of the WAD1700 line what ever whichever is most forward.

7.3.32.1. These minimum distances are to be set with a flexible tape held tautly along the outer surface of the vehicle. ~~If, however, the vehicle configuration does not allow the number of eighteen impact points to be reached while maintaining the minimum spacing between impact points, then less than eighteen tests may be performed.~~

7.3.32.2. The points selected for testing shall be indicated in the test report.

7.3.43. The point of first contact of the headform impactor shall be [within a  $\pm 10$  mm tolerance to the selected impact ~~location~~point.]

7.3.54. The headform velocity at the time of impact shall be [8.9-9.7  $\pm 0.2$  m/s, (32km/h)] ~~[which simulates the vehicle impact speed of 40 km/h, the shape category of the vehicle under test and the location of each selected test point.]~~

~~The effect of gravity shall be taken into account when the impact velocity is obtained from measurements taken before the time of first contact.~~

7.3.65. The direction of impact shall be as specified as follows:

~~7.3.6.1.~~ The direction of impact shall be in the longitudinal vertical plane of the vehicle to be tested at an angle of 50° to the horizontal. [The situation of windscreen is to be confirmed prior to the next meeting]. The tolerance for this direction is  $\pm 2^\circ$ . The direction of impact of tests to the front structure shall be downward and rearward.

~~The following two sections will depend on the agreement of approach to the use of variable angles~~

~~7.3.6.2.~~ ~~For vehicles where the bonnet angle, as defined in paragraph 3.3, is not lower than 30°, the angle of impact on the bonnet shall be~~

~~25° ± [2]° for tests point on the bonnet top, as defined in paragraph 3.8 or  
25° ± [2]° for test point in the windscreen test area, as defined in paragraph 3.36~~

~~to the Ground Reference Level.~~

~~7.3.6.3. For vehicles where the bonnet angle, as defined in paragraph 3.3., is lower than 30°:~~

~~7.3.6.3.1. If the bonnet leading edge height (BLEH), as defined in paragraph 3.5., is not lower than 835 mm, the angle of impact on the bonnet shall be~~

~~60° ± [2]° for tests point on the bonnet top, as defined in paragraph 3.8.  
or  
40° ± [2]° for test point in the windscreen test area, as defined in paragraph 3.36.~~

~~to the Ground Reference Level.~~

~~7.3.6.3.2. If the bonnet leading edge height (BLEH), as defined in paragraph 3.5., is lower than 835 mm, the angle of impact on the bonnet shall be~~

~~65° ± [2]° for tests point on the bonnet top, as defined in paragraph 3.8.  
or  
40° ± [2]° for test point in the windscreen test area, as defined in paragraph 3.36.~~

~~to the Ground Reference Level.]~~

~~7.3.6.4. [The effect of gravity shall be taken into account when the impact angle is obtained from measurements taken before the time of first contact.]~~

#### 7.4. Adult headform test procedure:

This test procedure is applicable with respect to the requirements of paragraph 5.2.2. and 5.2.3. of the performance requirements of this Regulation.

7.4.1. Tests shall be made to the front structure within the boundaries as defined in paragraph 3.1. For tests at the rear of the bonnet top, the headform impactor shall not contact the windscreen or A-pillar before impacting the bonnet top.

~~7.4.2. [A minimum of [eighteen 9nine] tests shall be carried out with the adult headform impactor, [six 3three] tests each to the middle and the outer thirds of the test area, as described in paragraph 3.25., at positions judged to be the most likely to cause injury. Tests shall be to different types of structure, where these vary throughout the area to be assessed.]~~

7.4.32. No impact point shall be located so that the impactor will impact the test area with a glancing blow resulting in a more severe second impact.  
Selected impact points on the bonnet for the adult headform impactor shall, at the time of first contact:

~~The Any test points shall be located so that the impactor is will not expected to impact the test area with a glancing blow resulting in a more severe second impact. The Any The selected test points on the bonnet for the adult headform impactor shall, at the time of first contact:~~

- ~~\_\_\_\_\_ be a minimum of 165 mm apart,~~
- be a minimum of 165 mm apart, and
- be a minimum of 82.5 mm inside the defined bonnet side reference lines, and, as defined in paragraph 3.23.
- be forward of the WAD2100 line or a minimum of 82.5 mm forwards of the bonnet rear reference line, as defined in paragraph 3.7, or forwards of the WAD2100 line what, whichever is most forward, and
- be rearward of the WAD1700 line.
- ~~\_\_\_\_\_ [specify min time in between tests]~~

If the rear reference line for adult headform, as defined in paragraph 3.21, is located, at any point, in the windscreen test area, as defined in paragraph 3.36 impact points selected on the windscreen test area for the adult headform impactor shall, at time of first contact:

partly on or forward the rear windscreen reference line, as defined in paragraph 3.23, [two] selected tests points in the windscreen test area, as defined in paragraph 3.36, for the adult headform impactor shall, at the time of first contact:

- ~~- be a minimum of 165 mm apart,~~
- be forward of the rear reference line for adult headform or a minimum of 82.5 mm forward of the windscreen rear reference line for adult headform, as defined in paragraph 3.2135, whichever is most forward;
- be rearward of the WAD1700 line or a minimum of 82.5 mm rearwards of the windscreen lower reference line, as defined in paragraph 3.33. (see paragraph 3.33.) or rearwards of the WAD1700 line what whichever is most rearward.

~~\_\_\_\_\_ Each selected test point for the adult headform shall also be a minimum of 165 mm rearwards of the bonnet leading edge reference line, as defined in paragraph 3.6.~~

7.4.32.1. These minimum distances are to be set with a flexible tape held tautly along the outer surface of the vehicle. ~~If, however, the vehicle configuration does not allow the number of eighteen impact points to be reached while maintaining the~~

~~minimum spacing between impact points, then less than eighteen tests may be performed.~~

7.4.32.2. The points selected for testing shall be indicated in the test report.

7.4.43. The point of first contact of the headform impactor shall be within a  $\pm 10$  mm tolerance to the selected impact location point.

7.4.54. The headform velocity at the time of impact shall be ~~[8.9.9.7  $\pm 0.2$  m/s (32 km/h)]~~ [which simulates the vehicle impact speed of 40 km/h, the shape category of the vehicle under test and the location of each selected test point.]

~~The effect of gravity shall be taken into account when the impact velocity is obtained from measurements taken before the time of first contact~~

7.4.65. The direction of impact shall be as specified as follows

~~7.4.6.1.~~ The direction of impact shall be in the fore and aft vertical plane of the paragraph of the vehicle to be tested at an angle of 65° to the horizontal [The situation of windscreen is to be confirmed prior to the next meeting]. The tolerance for this direction is  $\pm 2^\circ$ . The direction of impact of tests to the front structure shall be downward and rearward.

~~The following two sections will depend on the agreement of approach to the use of variable angles.~~

~~7.4.6.2. For vehicles where the bonnet angle, as defined in paragraph 3.3., is not lower than 30°, the angle of impact in all cases shall be~~

~~50°  $\pm$  [2]° for tests point on the bonnet top, as defined in paragraph 3.8.~~

~~or~~

~~50°  $\pm$  [2]° for test point in the windscreen test area, as defined in paragraph 3.36.~~

~~to the Ground Reference Level.~~

~~7.4.6.3. For vehicles where the bonnet angle, as defined in paragraph 3.3., is lower than 30°:~~

~~7.4.6.3.1. If the bonnet leading edge height (BLEH), as defined in paragraph 3.5., is not lower than 835 mm, the angle of impact on the bonnet shall be 90°  $\pm$  [2]°~~

~~90°  $\pm$  [2]° for tests point on the bonnet top, as defined in paragraph 3.8.~~

~~or~~

~~40° ± [2]° for test point in the windscreen test area, as defined in paragraph 3.36.~~

~~to the Ground Reference Level.~~

~~7.4.6.3.2. If the bonnet leading edge height (BLEH), as defined in paragraph 3.5., is lower than 835 mm, the angle of impact on the bonnet shall be~~

~~65° ± [2]° for tests point on the bonnet top, as defined in paragraph 3.8.~~

~~or~~

~~40° ± [2]° for test point in the windscreen test area, as defined in paragraph 3.36.~~

~~to the Ground Reference Level.]~~

~~7.4.6.4. The effect of gravity shall be taken into account when the impact angle is obtained from measurements taken before the time of first contact.~~

## 8. CERTIFICATION OF IMPACTORS

The impactors that are used in the tests ~~detailed~~ described in this gtr are required to comply with appropriate the following performance requirements.

The requirements for the lower legform impactor are specified in paragraph Section 8.1., the upper legform impactor requirements are specified in paragraph Section 8.2. and the adult and child headform impactors requirements are specified in paragraph Section 8.3.

### 8.1. Lower Legform legform Impactor-impactor Certificationcertification

#### 8.1.1. Static tests

8.1.1.1. The lower legform impactor shall meet the requirements specified in paragraph 8.1.1.2. when tested as specified in paragraph 8.1.1.4. and the impactor shall meet the requirements specified in paragraph 8.1.1.3. when tested as specified in paragraph 8.1.1.5.

For both tests the impactor shall have the intended orientation about its longitudinal axis, for the correct operation of its knee joint, with a tolerance of ± 2°.

The ~~stabilized~~ stabilised temperature of the impactor during certification shall be 20° ± 2°-C.

The CAC response values, as defined in ISO 6487:~~2000,2002~~ shall be 50° for the knee bending angle and 500 N for the applied force when the impactor is loaded in bending in accordance with paragraph 8.1.1.4., and 10 mm for the shearing displacement and 10 kN for the applied force when the impactor is loaded in



shearing in accordance with paragraph 8.1.1.5. For both tests low-pass filtering at an appropriate frequency is permitted, to remove higher frequency noise without significantly affecting the measurement of the response of the impactor.

8.1.1.2. When the impactor is loaded in bending in accordance with paragraph 8.1.1.4., the applied force/bending angle response shall be within the limits shown in Figure 20. Also, the energy taken to generate 15.0° of bending shall be  $100 \pm 7$  J.

8.1.1.3. When the impactor is loaded in shearing in accordance with paragraph 8.1.1.5., the applied force/shearing displacement response shall be within the limits shown in Figure 21.

8.1.1.4. The impactor, without foam covering and skin, shall be mounted with the tibia firmly clamped to a fixed horizontal surface and a metal tube connected firmly to the femur, as shown in Figure 22. To avoid friction errors, no support shall be provided to the femur section or the metal tube. The bending moment applied at the centre of the knee joint, due to the weight of the metal tube and other components (excluding the legform itself), shall not exceed 25 Nm.

A horizontal normal force shall be applied to the metal tube at a distance of  $2.0 \pm 0.01$  m from the centre of the knee joint and the resulting angle of knee deflection shall be recorded. The load shall be increased until the angle of deflection of the knee is in excess of 22°.

The energy is calculated by integrating the force with respect to the bending angle in radians, and multiplying by the lever length of  $2.0 \pm 0.01$  m.

8.1.1.5. The impactor, without foam covering and skin, shall be mounted with the tibia firmly clamped to a fixed horizontal surface and a metal tube connected firmly to the femur and restrained at 2.0 m from the centre of the knee joint, as shown in Figure 23.

A horizontal normal force shall be applied to the femur at a distance of 50 mm from the centre of the knee joint and the resulting knee shearing displacement shall be recorded. The load shall be increased until the shearing displacement of the knee is in excess of 8.0 mm or the load is in excess of 6.0 kN.

8.1.2. Dynamic tests

8.1.2.1. The lower legform impactor shall meet the requirements specified in paragraph 8.1.2.2. when tested as specified in paragraph 8.1.2.4.

8.1.2.2. The ~~stabilized~~ stabilised temperature of the impactor during certification shall be  $20^{\circ} \pm 2^{\circ}$ -C.

8.1.2.2.1. The relative humidity of a controlled storage area where all test impactors are stored shall be 40%  $\pm$ 30% after a stabilised period of at least four hours prior to impactor removal for calibration.

8.1.2.2.1. Each calibration shall be completed within two hours of when the impactor to be calibrated is removed from the controlled storage area.

8.1.2.2.1. Relative humidity and temperature of the calibration area shall be measured at the time of the calibration, and recorded in the calibration report.

8.1.2.23. When the impactor is impacted by a linearly guided certification impactor, as specified in paragraph 8.1.2.4., the maximum upper tibia acceleration shall be not less than 120 g and not more than 250 g. The maximum bending angle shall be not less than 6.2° and not more than 8.2°. The maximum shearing displacement shall be not less than 3.5 mm and not more than 6.0 mm.

For all these values, the readings used shall be from the initial impact with the certification impactor and not from the arresting phase. Any system used to arrest the impactor or certification impactor shall be so arranged that the arresting phase does not overlap in time with the initial impact. The arresting system shall not cause the transducer outputs to exceed the specified CAC.

8.1.2.34. The instrumentation response value CFC, as defined in ISO 6487:20002002, shall be 180 for all transducers. The CAC response values, as defined in ISO 6487:20002002, shall be 50° for the knee bending angle, 10 mm for the shearing displacement \_\_\_ and 500 g for the acceleration. This does not require that the impactor itself be able to physically bend and shear to these angles and displacements.

8.1.2.45. Test procedure

8.1.2.45.1. The impactor, including foam covering and skin, shall be suspended horizontally by three wire ropes of 1.5<sub>-±-0.2</sub>-mm diameter and of 2-000 mm minimum length, as shown in Figure 24. It shall be suspended with its longitudinal axis horizontal, with a tolerance of ± 0.5°, and perpendicular to the direction of the certification impactor motion, with a tolerance of ± 2°. The impactor shall have the intended orientation about its longitudinal axis, for the correct operation of its knee joint, with a tolerance of ± 2°. The impactor must meet the requirements of paragraph 6.3.1.1., with the attachment bracket(s) for the wire ropes fitted.

8.1.2.45.2. The certification impactor shall have a mass of 9.0 ± 0.05 kg, this mass includes those propulsion and guidance components which are effectively part of the impactor during impact. The dimensions of the face of the certification impactor shall be as specified in Figure 25. The face of the certification impactor shall be made of aluminium, with an outer surface finish of better than 2.0 micrometers.

The guidance system shall be fitted with low friction guides, insensitive to off-axis loading, that allow the impactor to move only in the specified direction of impact, when in contact with the vehicle. The guides shall prevent motion in other directions including rotation about any axis.

- 8.1.2.45.3. The impactor shall be certified with previously unused foam.
- 8.1.2.45.4. The impactor foam shall not be excessively handled or deformed before, during or after fitting.
- 8.1.2.45.5. The certification impactor shall be propelled horizontally at a velocity of  $7.5 \pm 0.1$  m/s into the stationary impactor as shown in Figure 25. The certification impactor shall be positioned so that its centreline aligns with a position on the tibia centreline of 50 mm from the centre of the knee, with tolerances of  $\pm 3$  mm laterally and  $\pm 3$  mm vertically.

## 8.2. Upper Legform Impactor

- 8.2.1. The upper legform impactor shall meet the requirements specified in paragraph 8.2.2 when tested as specified in paragraph 8.2.3.

8.2.1.1. The ~~stabilized~~stabilised temperature of the impactor during certification shall be  $20^{\circ} \pm 2^{\circ}$  C.

8.2.1.1.1. The relative humidity of a controlled storage area where all test impactors are stored shall be 40%  $\pm$ 30% after a stabilised period of at least four hours prior to impactor removal for calibration.

8.2.1.1.2. Each calibration shall be completed within two hours of when the impactor to be calibrated is removed from the controlled storage area.

8.2.1.1.3. Relative humidity and temperature of the calibration area shall be measured at the time of the calibration, and recorded in the calibration report.

## 8.2.2. Requirements

- 8.2.2.1. When the impactor is propelled into a stationary cylindrical pendulum the peak force measured in each load transducer shall be not less 1.20 kN and not more than 1.55 kN and the difference between the peak forces measured in the top and bottom load transducers shall not be more than 0.10 kN. Also, the peak bending moment measured by the strain gauges shall not be less than 190 Nm and not more than 250 Nm on the centre position and not less than 160 Nm and not more than 220 Nm for the outer positions. The difference between the upper and lower peak bending moments shall not be more than 20 Nm.

For all these values the readings used shall be from the initial impact with the pendulum and not from the arresting phase. Any system used to arrest the impactor or pendulum shall be so arranged that the arresting phase does not overlap in time with the initial impact. The arresting system shall not cause the transducer outputs to exceed the specified CAC.

8.2.2.2. The instrumentation response value CFC, as defined in ISO 6487:20002002, shall be 180 for all transducers. The CAC response values, as defined in ISO 6487:20002002, shall be 10 kN for the force transducers and 1\_000 Nm for the bending moment measurements.

8.2.3. Test procedure

8.2.3.1. The impactor shall be mounted to the propulsion and guidance system, by a torque limiting joint. The torque limiting joint shall be set so that the longitudinal axis of the front member is perpendicular to the axis of the guidance system, with a tolerance of  $\pm 2^\circ$ , with the joint friction torque set to ~~a minimum of 6750~~  $\pm 25$  -Nm. The guidance system shall be fitted with low friction guides that allow the impactor to move only in the specified direction of impact, when in contact with the pendulum.

8.2.3.2. The impactor mass shall be adjusted to give a mass of  $12 \pm 0.1$  -kg, this mass includes those propulsion and guidance components which are effectively part of the impactor during impact.

8.2.3.3. The centre of gravity of those parts of the impactor which are effectively forward of the torque limiting joint, including the extra weights fitted, shall lie on the longitudinal centreline of the impactor, with a tolerance of  $\pm 10$  mm.

8.2.3.4. The impactor shall be certified with previously unused foam.

8.2.3.5. The impactor foam shall not be excessively handled or deformed before, during or after fitting.

8.2.3.6. The impactor with the front member vertical shall be propelled horizontally at a velocity of  $7.1 \pm 0.1$  -m/s into the stationary pendulum as shown in Figure 26.

8.2.3.7. The pendulum tube shall have a mass of  $3 \pm 0.03$  kg, a wall thickness of  $3 \pm 0.15$  mm and an outside diameter of  $150 \text{ mm} +1 \text{ mm} -4$  mm. Total pendulum tube length shall be  $275 \pm 25$  mm. The pendulum tube shall be made from cold finished seamless steel (metal surface plating is permissible for protection from corrosion), with an outer surface finish of better than 2.0 micrometers. It shall be suspended on two wire ropes of  $1.5 \pm 0.2$  -mm diameter and of 2.0 m minimum length. The surface of the pendulum shall be clean and dry. The pendulum tube shall be positioned so that the longitudinal axis of the cylinder is perpendicular to the front member (i.e. level), with a tolerance of  $\pm 2^\circ$ , and to the direction of impactor motion, with a tolerance of  $\pm 2^\circ$ , and with the centre of the pendulum tube aligned with the centre of the impactor front member, with tolerances of  $\pm 5$  -mm laterally and  $\pm 5$  -mm vertically.

8.3. Certification procedure for child and adult headform impactors

8.3.1. Drop test

#### 8.3.1.1. Performance Criteria

The headform impactors shall meet the requirements specified in paragraph 8.3.2 when tested as specified in paragraph 8.3.3.

#### 8.3.2. Requirements

8.3.2.1. When the headform impactors are dropped from a height of  $376_{-1}^{+1}$  mm in accordance with paragraph 8.3.3, the peak resultant acceleration measured by one triaxial (or three uniaxial) accelerometer (accelerometers) in the headform impactor shall be:

- for the child headform impactor not less than 245 g and not more than 300 g.

- for the adult headform impactor not less than 225 g and not more than 275 g.

The acceleration time curve shall be uni-modal.

8.3.2.2. The instrumentation response values CFC and CAC for each accelerometer shall be 1000 Hz and 500 g respectively as defined in ISO 6487: ~~2000~~2002.

#### 8.3.2.3. Temperature conditions

The headform impactors shall have a temperature of  $20_{-2}^{+2}$  °C at the time of impact. The temperature tolerances shall apply at a relative humidity of  $40 \pm 30\%$  ~~10 to 70 per cent~~ after a soak period of at least four hours prior to their application in a test.

8.3.2.4. After complying with the certification test, each headform impactor can be used for a maximum of 20 impact tests.

#### 8.3.3. Test Procedure

8.3.3.1. The headform impactor shall be suspended from a drop rig as shown in Figure 27.

8.3.3.2. The headform impactor shall be dropped from the specified height by means that ensure instant release onto a rigidly supported flat horizontal steel plate, over 50 mm thick and over 300 mm square which has a clean dry surface and a surface finish of between 0.2 and 2.0 micrometers.

8.3.3.3. The headform impactor shall be dropped with the rear face of the impactor ~~at~~ at the test angle ~~chosen~~ specified in paragraph 7.3.6. for the child headform impactor and in paragraph 7.4.6. for the adult headform impactor ~~XXX~~ with respect to the vertical as shown in Figure 27. The suspension of the headform impactor shall be such that it does not rotate during the fall.

8.3.3.4. The drop test shall be performed three times, with the headform impactor rotated 120° around its symmetrical axis after each test.

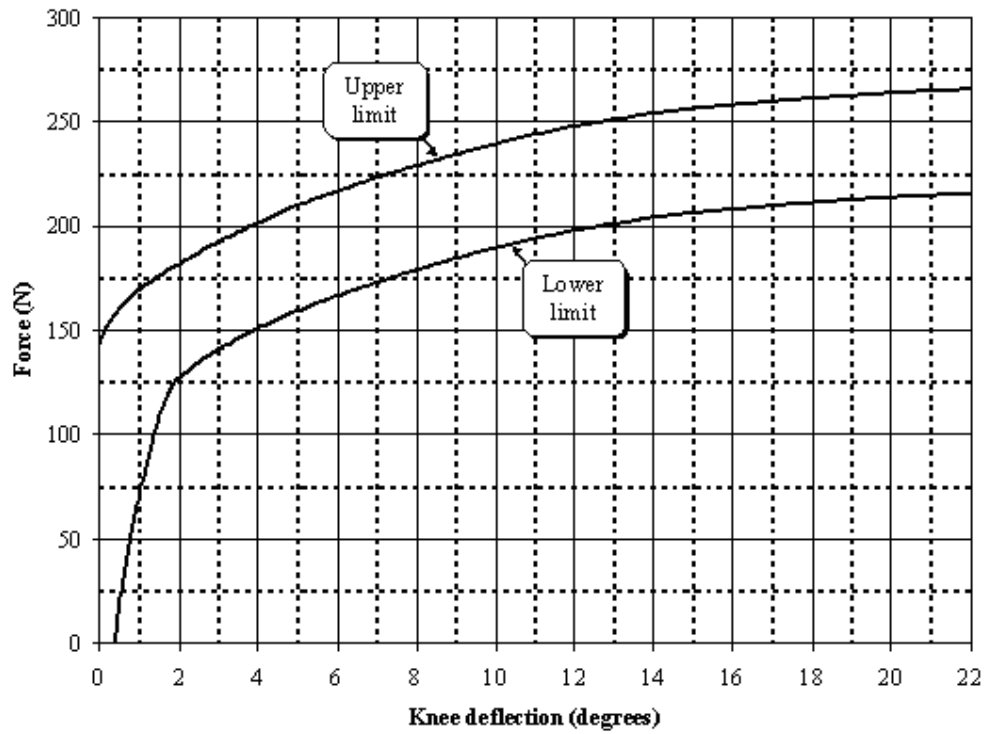

Figure 20. Force versus angle requirement in static lower legform impactor bending certification test (see §paragraph 8.1.1.2.)

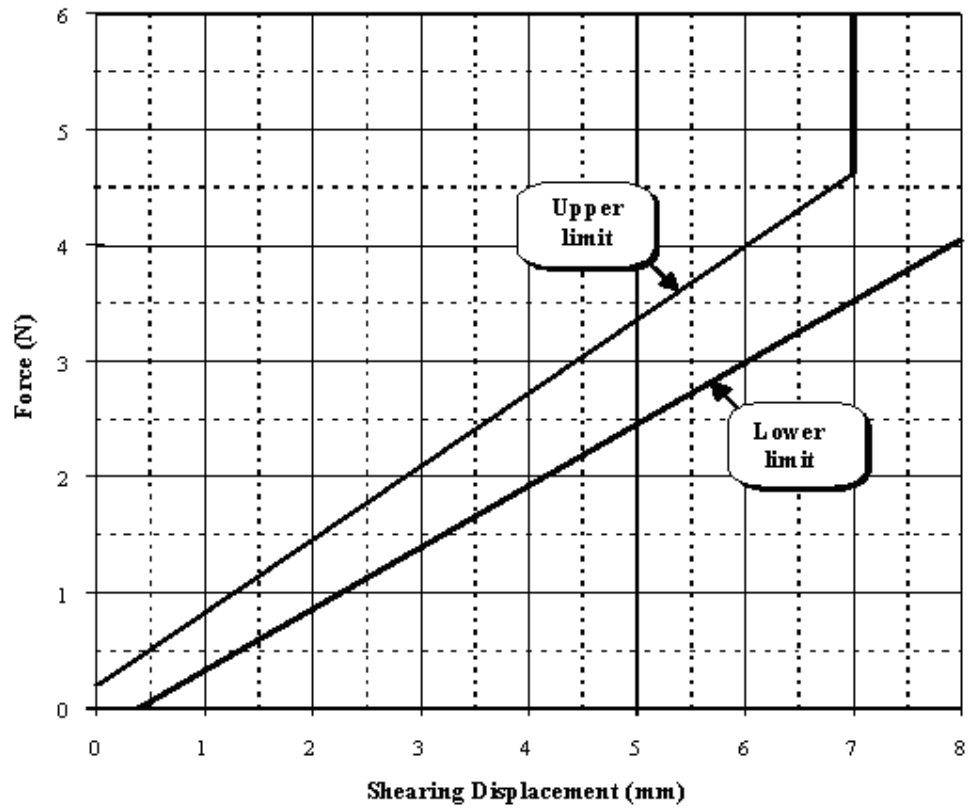

Figure 21. Force versus displacement requirement in static lower legform impactor shearing certification test (see §paragraph 8.1.1.3.)

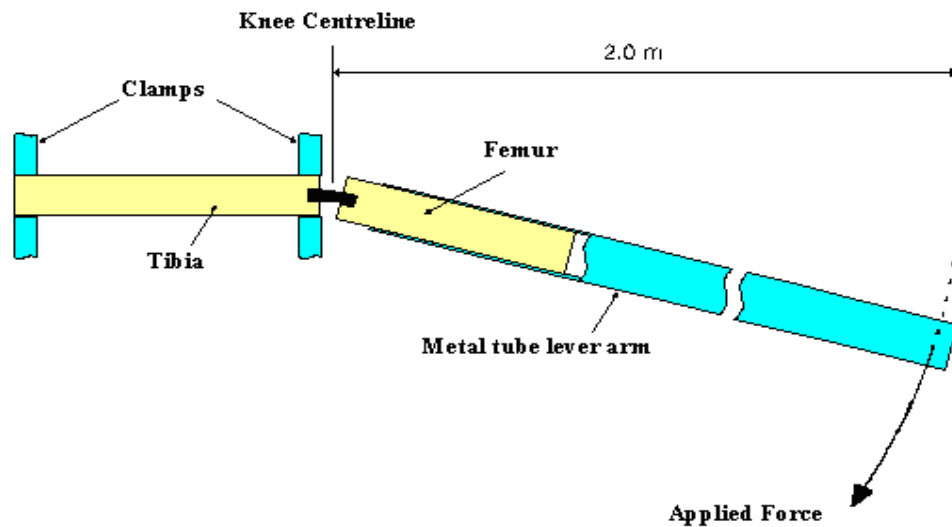

Figure 22. Top View of Test set-up for static lower legform impactor bending certification test (see §paragraph 8.1.1.4.)

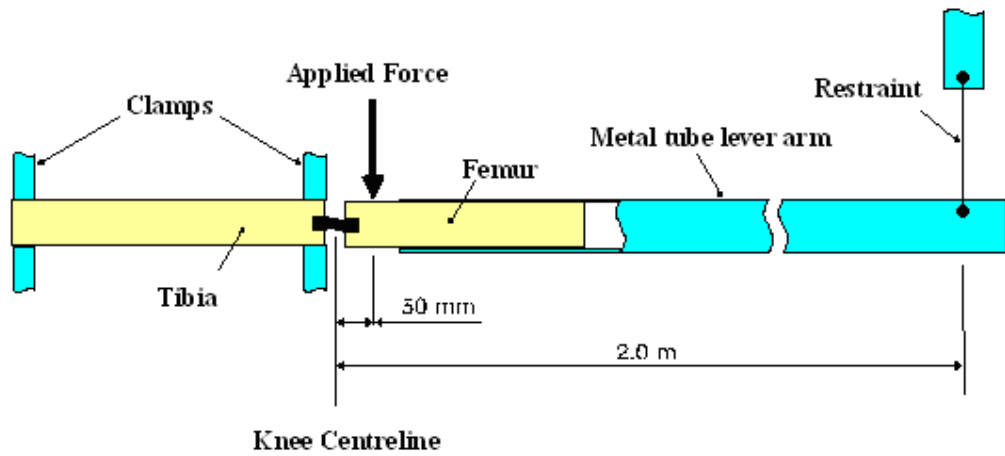

Figure 23. Top View of Test set-up for static lower legform impactor shearing certification test ([see §paragraph 8.1.1.5.](#))



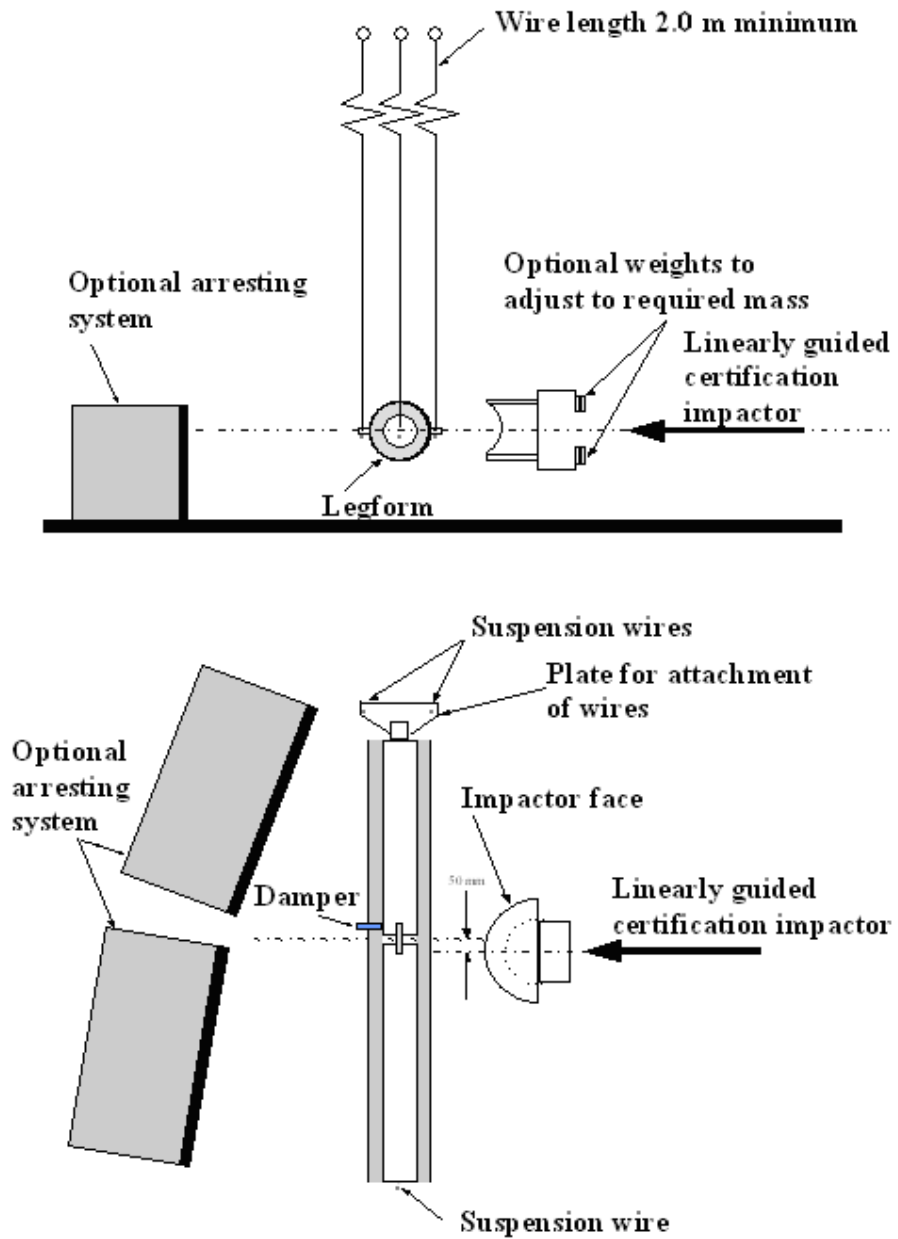

Figure 24. Test set-up for dynamic lower legform impactor certification test (side view top diagram, view from above bottom diagram) (see [§ paragraph 8.1.2.4.1.](#))

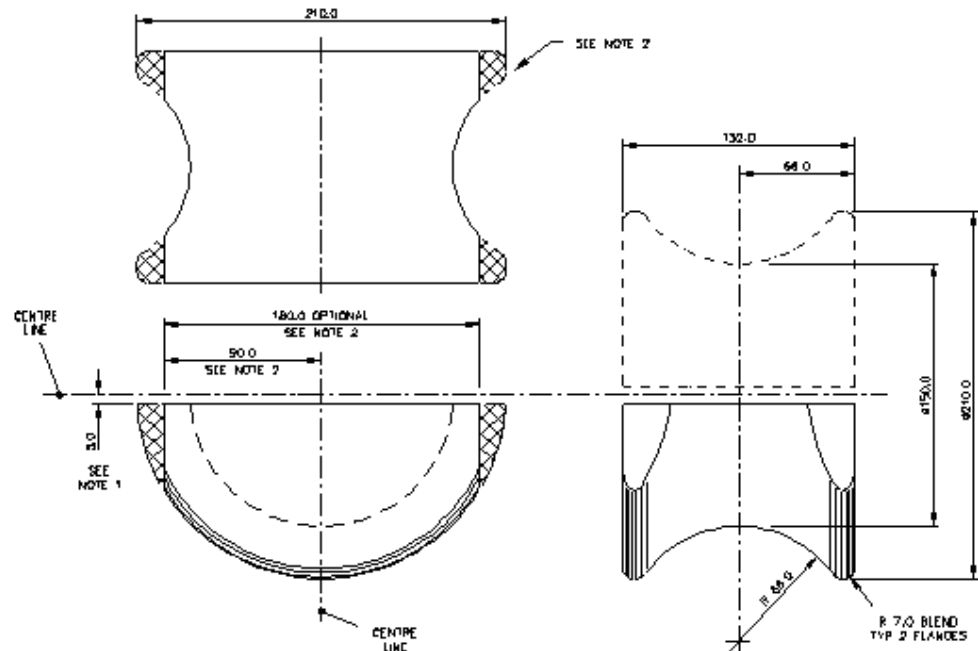

Figure 25. Details of dynamic lower legform certification impactor face  
(see [§paragraph 8.1.2.4.2.](#))

Notes:

1. Saddle may be made as a complete diameter and cut as shown to make two components.
2. The shaded areas may be removed to give the alternative form shown.
3. Tolerance on all dimensions is  $\pm 1.0$  mm.  
Material: Aluminium alloy

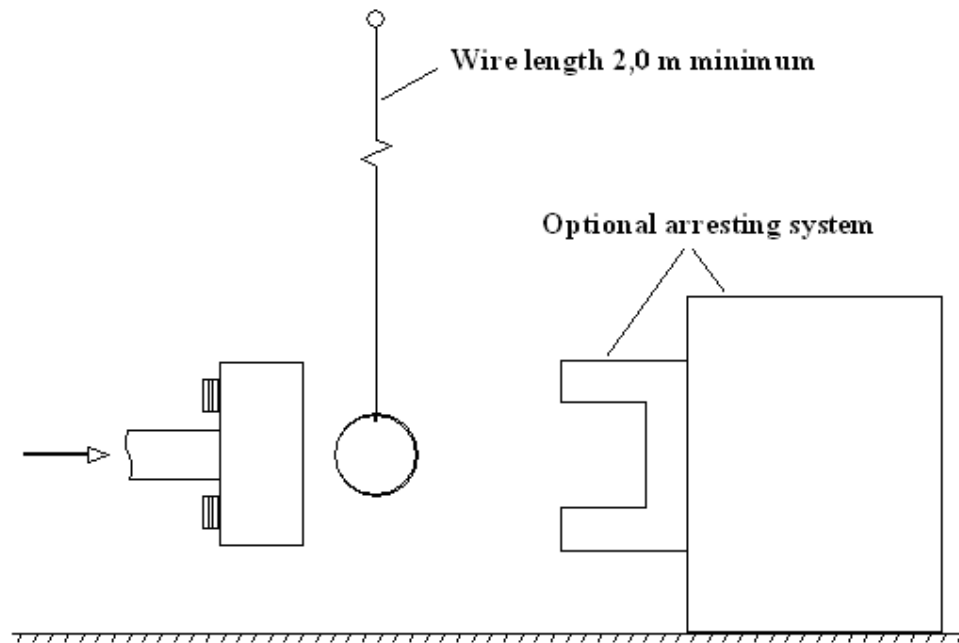

Figure 26. Test set-up for dynamic upper legform impactor certification test (see [paragraph 8.2.3.6](#))

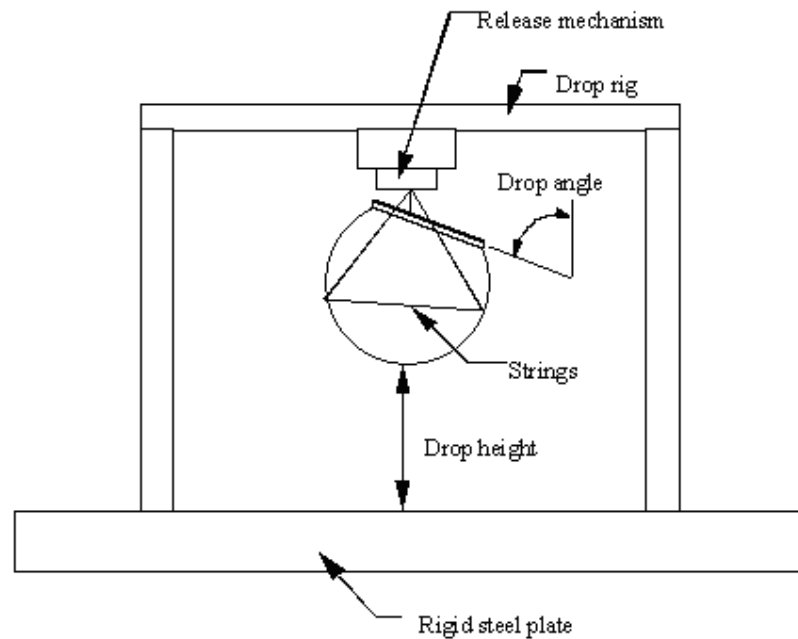

Figure 27. Test set-up for dynamic headform impactor biofidelity test (see [paragraph 8.3.3.1.](#))

[\[ANNEX 1: Example of gGuidelines for testing active devices designed to protect](#)

vulnerable road users when impacted by the vehicle.

ANNEX 2: Impactor handling procedures including:

- soaking conditions
  - time between soaking and testing
  - time in between tests]
-