

PROPOSAL FOR A GLOBAL TECHNICAL REGULATION ON

UNIFORM PROVISIONS CONCERNING THE APPROVAL OF VEHICLES WITH
REGARD TO THEIR CONSTRUCTION IN ORDER TO IMPROVE THE PROTECTION
AND MITIGATE THE SEVERITY OF INJURIES TO PEDESTRIANS AND OTHER
VULNERABLE ROAD USERS IN THE EVENT OF A COLLISION

B. TEXT OF THE REGULATION

1. PURPOSE AND SCOPE

- 1.1. The purpose of this global technical regulation is to bring about an improvement in the construction of the front of vehicles and, in particular, those areas which have been most frequently identified as causing injury when in collision with a pedestrian or other vulnerable road user. ~~[The tests required are limited to those elements of the child and adult body most frequently identified as sustaining injury, i.e. the adult head and leg and the child head. To achieve the required improvements in construction of vehicles, the tests are based on sub-system component impactors representing those body regions and impacted at speeds representative of that below which the majority of injuries occur.]~~
- 1.2. The vehicles to be tested under the regulation are representative of the majority of vehicles in circulation in the urban environment, where there is a greater potential for collision with pedestrians and other vulnerable road users, and include passenger cars, vans and light trucks.

2. APPLICATION

This global technical regulation (gtr) shall apply to the frontal surfaces of power driven vehicles of category 1-1 with a gross vehicle mass not exceeding 2.5 tonnes, and of category 2 with a gross vehicle mass not exceeding 2.5 tonnes, derived from category 1-1. All definitions of Special Resolution 1 shall apply as necessary.

It shall not apply to vehicles of category 1-1 or category 2 with a gross vehicle weight which does not exceed 0.5 tonnes.

~~[For the purpose of this gtr, vehicles of category 2 derived from category 1-1 means vehicles of category 2 which, forward of the A pillars, have the same general structure and shape as a pre-existing category 1-1 vehicle.]~~

3. DEFINITIONS

[When performing measurements as described in this Part, the vehicle should be positioned in its normal ride attitude.

If the vehicle is fitted with a badge, mascot or other structure which would bend back or retract under a low applied load, then such a load shall be applied before and/or while these measurements are taken.

Any vehicle component which could change shape or position, such as 'pop-op' headlights, other than suspension components or active devices to protect pedestrians, shall be set to a shape or position that the test institutes, in consultation with the manufacturer, consider to be the most appropriate while taking these measurements.]

For the purposes of this regulation:

- 3.1. "Adult Headform Test Area" is an area on the outer surfaces of the front structure~~[, as defined in paragraph 3.14].~~

The area is bounded, in the front, by a wrap around distance of 1700 mm~~[, as defined in paragraph 3.31,]~~ and, at the rear, by the rear reference line for adult headform~~[, as defined in paragraph 3.21,]~~ and, at each side, by the side reference~~[line as defined in paragraph 3.22].~~

- 3.2. "A-pillar" means the foremost and outermost roof support extending from the chassis to the roof of the vehicle.
- 3.3. "Bonnet leading edge" means the [edge of the] front upper outer structure [of the vehicle,] including the bonnet and wings, the upper and side members of the headlight surrounds and any other attachments. The reference line identifying the position of the bonnet leading edge is defined by its height above the ground reference plane and by the horizontal distance separating it from the bumper (bumper lead)~~[, as determined in accordance with paragraphs 3.5, 3.15, and 3.9, respectively].~~
- 3.4. "Bonnet leading edge height" means~~[, at any point on the bonnet leading edge,]~~ the vertical distance between the ground reference plane and the bonnet leading edge reference line~~[at that point], [as defined in paragraph 3.5,]~~ with the vehicle positioned in its normal ride attitude.
- 3.5. "Bonnet leading edge reference line" means the geometric trace of the points of contact between a straight edge 1000 mm long and the front surface of the bonnet, when the straight edge, held parallel to the vertical longitudinal plane of the car and inclined rearwards by ~~50°~~[40°] from the vertical and with the lower end 600 mm above the ground, is traversed across and in contact with the bonnet leading edge (see Figure 1.).

For vehicles having the bonnet top surface inclined at ~~50°~~[40°], so that the straight edge makes a continuous contact or multiple contacts rather than a point contact, determine the reference line with the straight edge inclined rearwards at an angle of ~~40°~~[35°] from the vertical.

For vehicles of such shape that the bottom end of the straight edge makes first contact with the vehicle then that contact is taken to be the bonnet leading edge reference line, at that lateral position.

For vehicles of such shape that the top end of the straight edge makes first contact with the vehicle then the geometric trace of 1000 mm wrap around distance, ~~[as defined in paragraph 3.29,]~~ will be used as bonnet leading edge reference line at that lateral position.

The top edge of the bumper shall also be regarded as the bonnet leading edge if it is contacted by the straight edge during this procedure.

- 3.6. "Bonnet rear reference line" means the geometric trace of the most rearward points of contact between a 165 mm diameter sphere and the front structure of the vehicle ~~[rear of~~

~~the bonnet]~~ when the sphere is traversed across the front structure of the vehicle ~~[bonnet]~~ while maintaining contact with the [lower] windscreen (see Figure 2.).

Where the bonnet rear reference line and the side reference line do not intersect, the bonnet rear reference line should be extended and/or modified using a semi-circular template, of radius 100 mm. The template should be made of a thin flexible sheet material that easily bends to a single curvature in any direction. The template should, preferably, resist double or complex curvature where this could result in wrinkling. The recommended material is a foam backed thin plastic sheet to allow the template to "grip" the surface of the vehicle. The template should be marked up with four points "A" through "D", as shown in Figure 3, while the template is on a flat surface.

The template should be placed on the vehicle with Corners "A" and "B" coincident with the side reference line. Ensuring these two corners remain coincident with the side reference line, the template should be slid progressively rearwards until the arc of the template makes first contact with the bonnet rear reference line. Throughout the process, the template should be curved to follow, as closely as possible, the outer contour of the vehicle's bonnet top, without wrinkling or folding of the template. If the contact between the template and bonnet rear reference line is tangential and the point of tangency lies outside the arc scribed by points "C" and "D", then the bonnet rear reference line is extended and/or modified to follow the circumferential arc of the template to meet the bonnet side reference line, as shown in Figure 4.

If the template cannot make simultaneous contact with the bonnet side reference line at points "A" and "B" and tangentially with the bonnet rear reference line, or the point at which the bonnet rear reference line and template touch lies within the arc scribed by points "C" and "D", then additional templates should be used where the radii are increased progressively in increments of 20 mm, until all the above criteria are met.

3.7. "Bonnet top" is the area which is bounded by (a), (b) and (c) as follows:

- a) the bonnet leading edge reference line~~[, as defined in paragraph 3.5.];~~
- b) the bonnet rear reference line~~[, as defined in paragraph 3.6.];~~
- c) the [bonnet] side reference lines~~[, as defined in paragraph 3.22].~~

3.8. "Bumper" means the front, lower, outer structure of a vehicle. It includes all structures that are intended to give protection to a vehicle when involved in a low speed frontal collision with another vehicle and also any attachments to this structure. The reference height and lateral limits of the bumper are identified by the corners and the bumper reference lines~~[, as defined in paragraphs 3.12., 3.18., 3.19., 3.26. and 3.27].~~

[3.9. "Bumper lead" [means] for any longitudinal section of a [vehicle.] [ear-] is the horizontal distance in the vehicle longitudinal plane between the upper bumper reference line~~[, as defined in paragraph 3.27.]~~ and the bonnet leading edge reference line~~[, as defined in paragraph 3.5.]~~

~~[3.10. "Bumper test area" means the frontal surface of the bumper limited by two longitudinal vertical planes intersecting the corners of the bumper as defined in paragraph 3.12. and moved 66 mm parallel and inboard of the corners of the bumpers.~~

3.4110. "Child Headform Test Area" is an area on the outer surfaces of the front structure~~;~~
~~as defined in paragraph 3.14].~~

The area is bounded, in the front, by the front reference line for child headform~~;~~
~~defined in paragraph 3.13.],~~ and, at the rear, by the WAD1700 line~~;~~
~~as defined in paragraph 3.29.],~~ and by the side reference lines~~;~~
~~as defined in paragraph 3.22].~~

3.4211. "Corner of bumper" means the vehicle's point of contact with a vertical plane which makes an angle of 60° with the vertical longitudinal plane of the car and is tangential to the outer surface of the bumper (see Figure 5).

~~[3.12. "Vehicles of category 2 derived from category 1-1" means vehicles of category 2 which, forward of the A-pillars, have the same general structure and shape as a pre-existing category 1-1 vehicle.~~

3.13. "Front reference line for Child Headform" means the geometric trace as described on the vehicle front structure using a WAD1000 line~~;~~
~~as defined in paragraph 3.29].~~

In the case of vehicles where the wrap around distance to the bonnet leading edge reference line, ~~as defined in paragraph 3.5.],~~ is more than 1000 mm at any point, then the bonnet leading edge reference line will be used as the front reference line for child headform at that point.

3.14. "Front structure" means all ~~outer structures]~~~~[parts]~~ of the vehicle including the windscreen, the windscreen header, the A-pillars and all parts of the vehicle forward of these. It therefore includes, but is not limited to, the bonnet, wings, scuttle, wiper spindles, windscreen and lower windscreen frame.

3.15. "Ground reference plane" means a ~~flat~~ horizontal plane, either real or imaginary, that passes through the lowest points of contact for all tyres of a vehicle while the vehicle is in its normal ride attitude. If the vehicle is resting on the ground, then the ground level and the ground reference plane are one and the same. If the vehicle is raised off the ground such as to allow extra clearance below the bumper, then the ground reference plane is above ground level.

3.16. "Head ~~Performance]~~~~[Injury]~~ Criterion (HIC)" means the calculated result of accelerometer time histories using the following formula:

$$\text{HIC-HPC} = \left[\frac{1}{t_2 - t_1} \int_{t_1}^{t_2} a \, dt \right]^{2.5} (t_2 - t_1)$$

Where:

a is the resultant acceleration measured in units of gravity "g" (1 g = 9.81 m/s²);

t_1 and t_2 are the two time instants (expressed in seconds) during the impact, defining an interval between the beginning and the end of the recording period for which the value of ~~[HPC][HIC]~~ is a maximum
($t_2 - t_1 \leq [15]$ ms)

- 3.17. "Impact point" means the point on the vehicle where initial contact by the test impactor occurs. The proximity of this point to the target point is dependent upon both the angle of travel by the test impactor and the contour of the vehicle surface (see point B in Figure 6).
- 3.18. "Lower bumper height" means the vertical distance between the ground [reference plane] and the lower bumper reference line, ~~[as defined in paragraph 3.19.,]~~ with the vehicle positioned in its normal ride attitude.
- 3.19. "Lower bumper reference line" means the lower limit to significant points of pedestrian contact with the bumper. It is defined as the geometric trace of the lowermost points of contact between a straight edge 700 mm long and the bumper, when the straight edge, held parallel to the vertical longitudinal plane of the car and inclined forwards by 25° from the vertical, is traversed across the front of the car, while maintaining contact with the ground and with the surface of the bumper (see Figure 7.).
- 3.20. "Normal ride attitude" means the vehicle [positioned on a flat horizontal surface with]~~[attitude when it is at]~~ its mass in running order (as defined in Annex 3, paragraph 3 of Special Resolution 1), with the tyres inflated to manufacturer recommended pressures, the front wheels in the straight-ahead position and with a passenger mass (as defined in Annex 3, paragraph 6.2. of Special Resolution 1) placed on the front passenger seat. The front seats are placed at the nominal mid-track position. The suspension shall be set in normal running condition as specified by the manufacturer ~~([for a speed of 40 km/h].~~
- 3.21. "Rear reference line for Adult Headform" means a geometric trace as described on the front structure of the vehicle using a WAD2100 line~~[as defined in paragraph 3.29].~~

In the case of vehicles where the wrap around distance of 2100 mm, at any point, is above the vertical limit reference line~~[as defined in paragraph 3.28].~~ then the vertical limit reference line will be used as the rear reference line for the adult headform at that point.

~~[3.22. "Bumper test are" means the frontal surface of the bumper limited by two longitudinal vertical planes intersecting the corners of the bumper and moved 66 mm parallel and inboard of the corners of the bumpers.]~~

- 3.~~22~~3. "Side reference line" means the geometric trace of the highest points of contact between a straight edge 700 mm long and the sides of the [vehicle]~~[front structure, A-pillars or roof]~~, when the straight edge, held parallel to the transverse vertical plane of the vehicle and inclined inwards by 45°~~[and with the lower end 600 mm above the ground],~~ is traversed down~~[, and maintains contact with]~~ the sides of the front structure, A-pillars or roof~~[, while maintaining contact with the surface of the body shell]~~ (see Figure 8.).
- 3.~~23~~4. "Target Point" means the intersection of the projection of the headform longitudinal axis with the front surface of the vehicle (see point A in Figure 6.).

- [3.2425. "Third of the bonnet top" means the geometric trace between the ~~[bonnet-]~~side reference lines~~[, as defined in paragraph 3.22.]~~, measured with a flexible tape following the outer contour of the bonnet top, divided into three equal parts.]
- [3.2526. "Third of the bumper" means the geometric trace between the corners of the bumper~~[, as defined in paragraph 3.12.]~~, measured with a flexible tape following the outer contour of the bumper, divided into three equal parts.]
- [3.2627. "Upper bumper height" means the vertical distance between the ground [reference plane] and the upper bumper reference line~~[, as defined in paragraph 3.27.]~~, with the vehicle positioned in its normal ride attitude.
- [3.2728. "Upper bumper reference line" means the upper limit to significant points of pedestrian contact with the bumper. [For vehicles with an identifiable bumper structure it is defined as the geometric trace of the uppermost points of contact between a straight edge and the bumper, when the straight edge, held parallel to the vertical longitudinal plane of the car and inclined rearwards by 20° to the vertical, is traversed across the front of the car, while maintaining contact with the surface of the bumper (see Figure 9).

~~[For vehicles with no identifiable bumper structure it is defined as the geometric trace of the uppermost points of contact between a straight edge 700 mm long and the bumper area, when the straight edge, held parallel to the vertical longitudinal plane of the car and inclined rearwards by 20° from the vertical is traversed across the front of the car, while maintaining contact with the ground and with the surface of the bumper area (see Figure 9).]~~~~[It is defined as the geometric trace of the uppermost points of contact between a straight edge 700 mm long and the bumper, when the straight edge, held parallel to the vertical longitudinal plane of the car and inclined rearwards by 20° from the vertical, is traversed across the front of the car, while maintaining contact with the ground and with the surface of the bumper (see Figure 9). Where necessary the straight edge shall be shortened to avoid any contact with structures above the bumper.]~~

- 3.2829. "Vertical limit reference line" means a horizontal line on the vehicle at a vertical height of 1900 mm from the ground reference plane (see Figure 10.).
- 3.2930. "Wrap Around Distance (WAD)" [means][is] the geometric trace described on the frontal upper surface [of the vehicle] by one end of a flexible tape, when it is held in a vertical [longitudinal][fore and aft] plane of the vehicle and traversed across the front structure~~[, as defined in paragraph 3.14]~~. The tape is held taut throughout the operation with one end held at ground reference level, vertically below the front face of the bumper and the other end held in contact with the front structure (see Figure 11.). The vehicle is positioned in the normal ride attitude.
- This procedure shall be followed, using alternative tapes of appropriate lengths, to describe wrap around distances of 1000 mm (WAD1000), of 1700 mm (WAD1700) and of 2100 mm (WAD2100).
- 3.3031. "Windscreen" means the frontal glazing of the vehicle situated between the A-pillars.

- 3.3132. "Windscreen lower reference line" ~~[means the trace of all points which are the most rearward of two points determined on any longitudinal vertical plane of the vehicle as follows (see Figure 13c):~~
- ~~A point which is 82.5 mm rearward, on the windscreen surface, of the point of intersection of the windscreen and a 5° line, according to ECE R43, which is moved vertically downwards until meeting any point on the dashboard surface, and~~
 - ~~A point which is 165 mm rearward, on the windscreen surface, of the point of contact of a sphere of 165 mm diameter which also maintains contact with other parts of the vehicle front structure.]~~
- ~~to be defined, see Figure 13c. Definition to be proposed by EC.~~
- 3.3233. "Windscreen side reference line" ~~[means][is]~~ the trace of all points of intersection between the windscreen and a line which is perpendicular to the transverse plane of the vehicle and maintains a lateral offset of 82.5 mm inside the A-pillars (see Figure 13b.).
- 3.33. "Windscreen rear reference line" ~~[means][is]~~ a line parallel to, and at a distance of 82.5 mm from, the windscreen header, measured on the windscreen surface (see Figure 13a.).
- 3.34. "Windscreen test area" means an area of the windscreen bordered as follows (see Figure 12.):
- a) by a line 82.5 mm forward of the windscreen rear reference line ~~[-as defined in paragraph 3.33.];~~
 - b) by lines 82.5 mm inside each windscreen side reference line ~~[-as defined in paragraph 3.32.];~~
 - c) by a line 82.5 mm rearward of the windscreen lower reference line ~~[-as defined in paragraph 3.31].~~

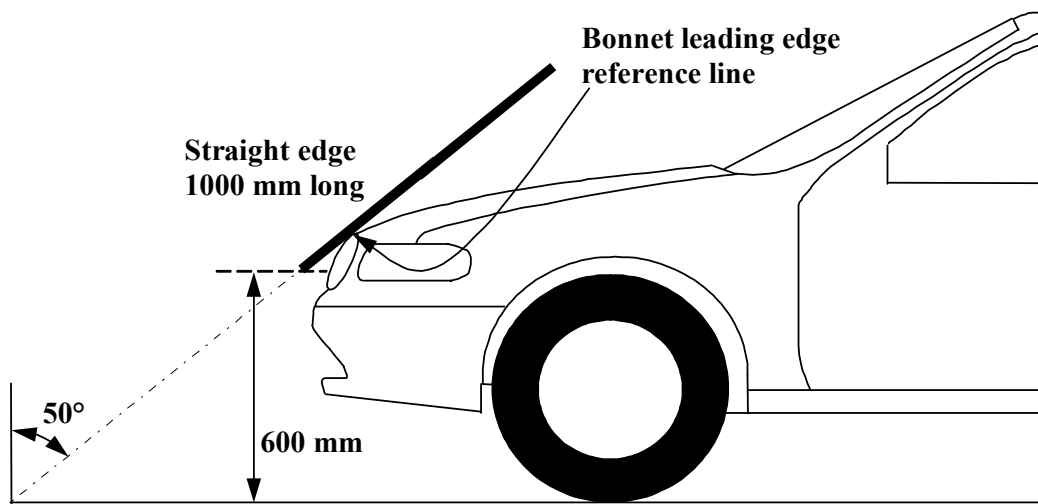

Figure 1: Bonnet leading edge reference line. (see paragraph 3.5.)

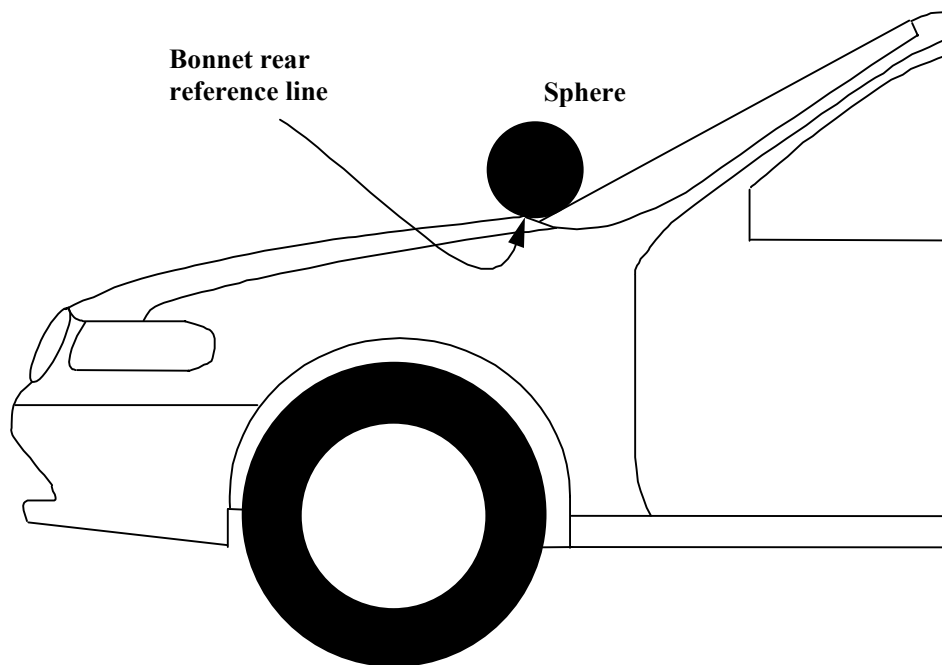

Figure 2: Bonnet rear reference line. (see paragraph 3.6.)

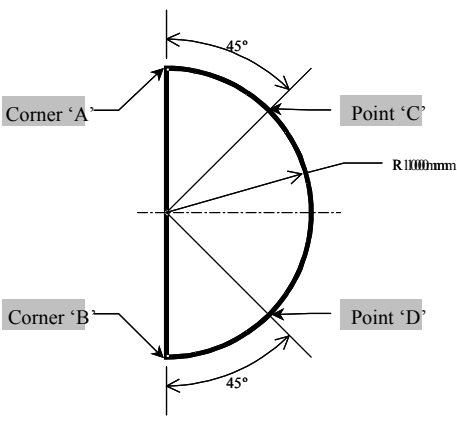

Figure 3: Template. (see paragraph 3.6.)

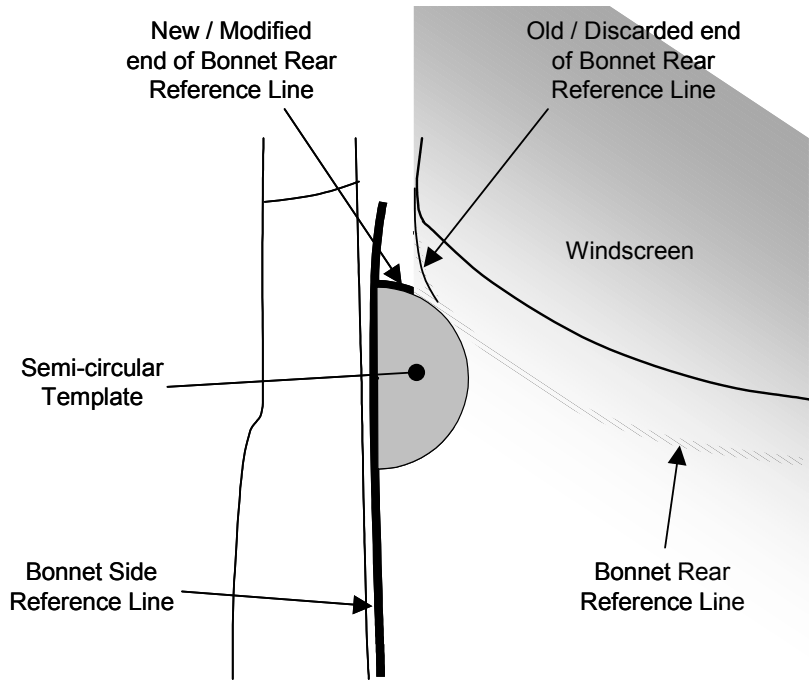

Figure 4: Marking of intersection between bonnet rear and side reference lines. (see paragraph 3.6.)

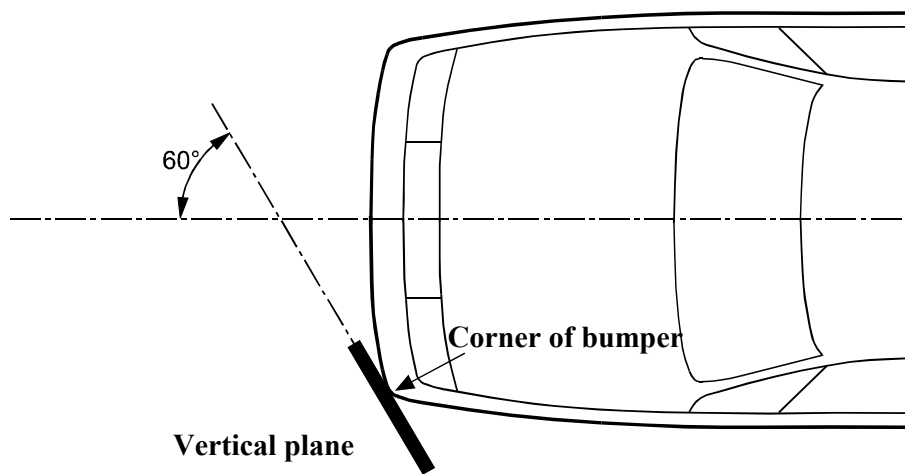

Figure 5: Corner of bumper (see paragraph 3.12.)

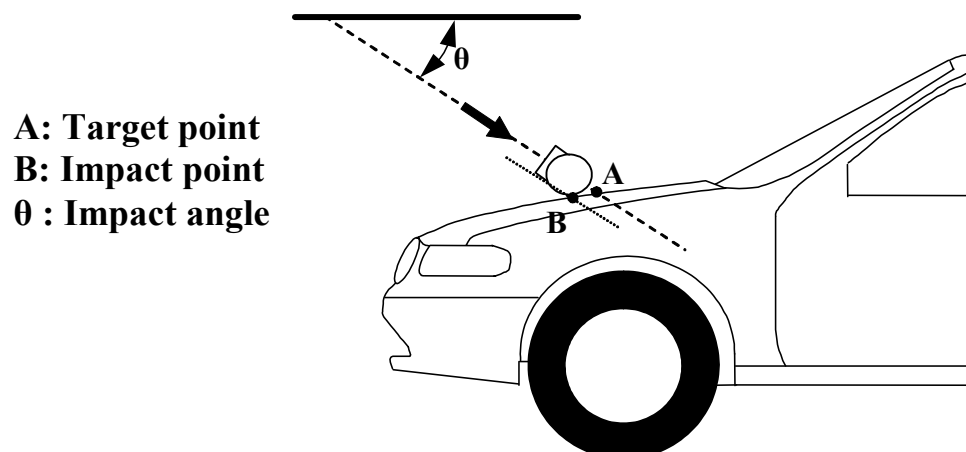

Figure 6: Impact and target point (see paragraph 3.17. and paragraph 3.23.)

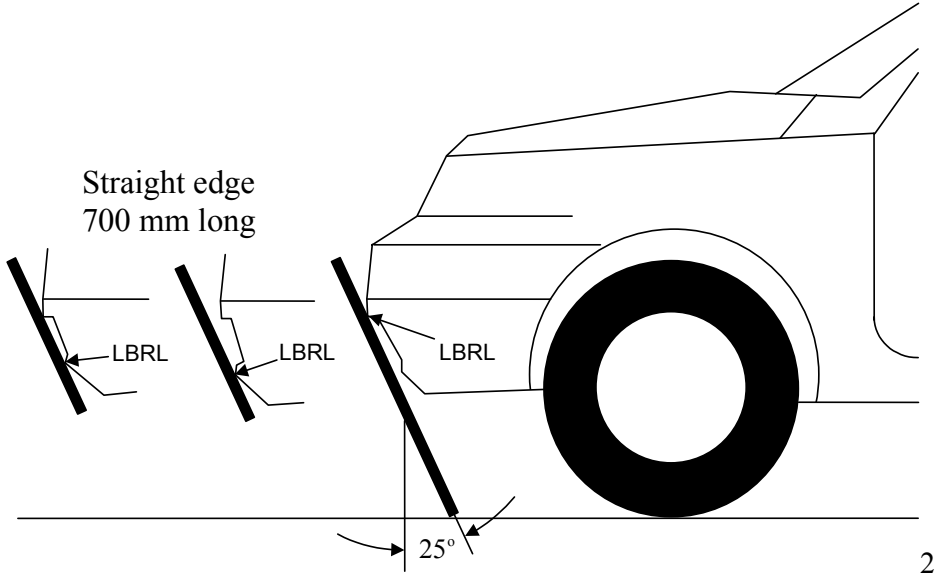

Figure 7: Lower bumper reference line, LBRL (see paragraph 3.19.)

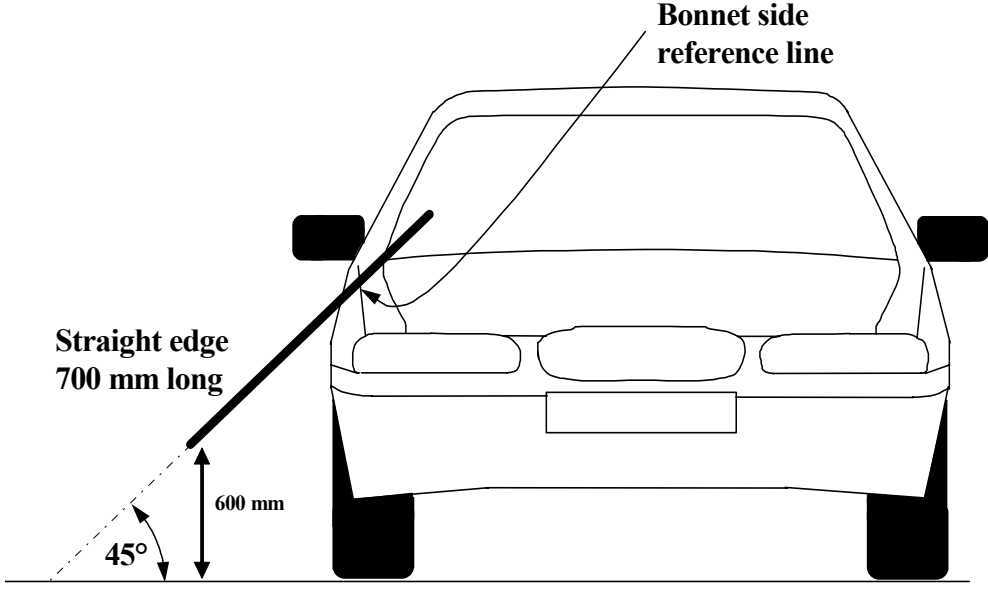
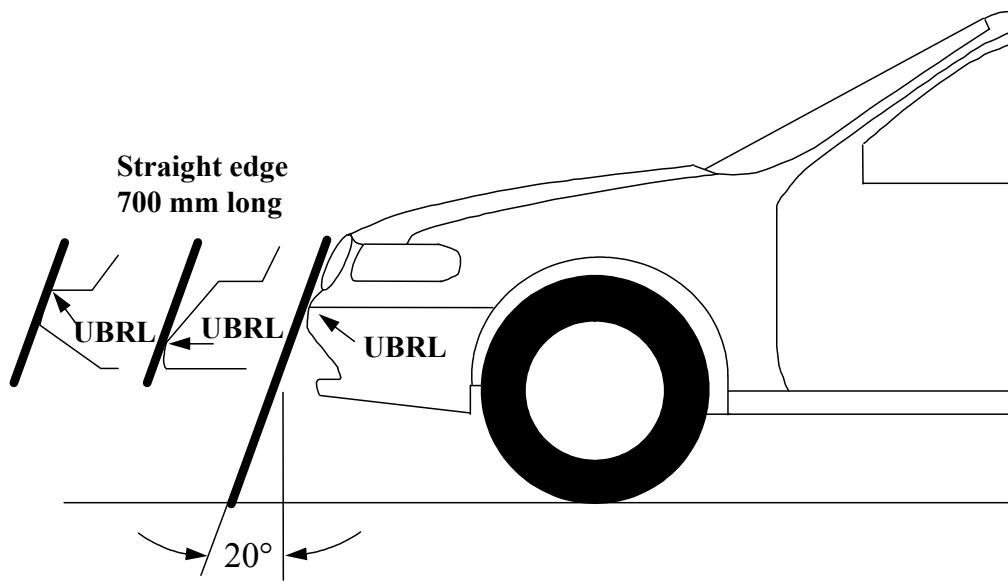

Figure 8: Side reference line (see paragraph 3.22.)



[Figure 9: Upper bumper reference line, UBRL (see paragraph 3.27.)]

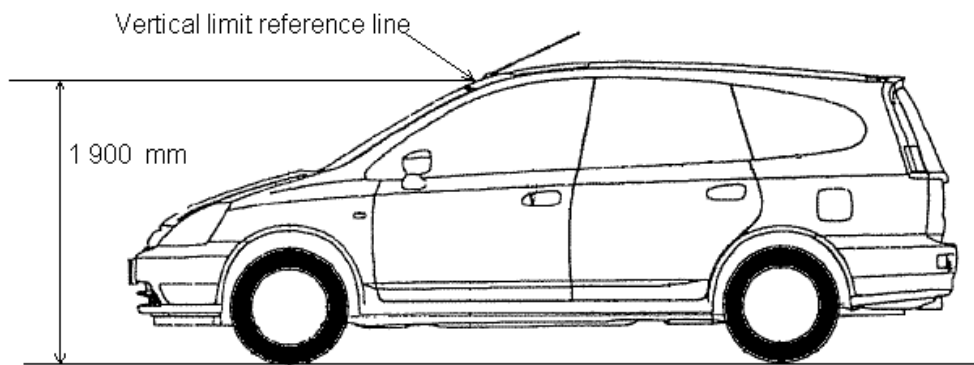

Figure 10: Vertical limit reference line (see paragraph 3.28.)

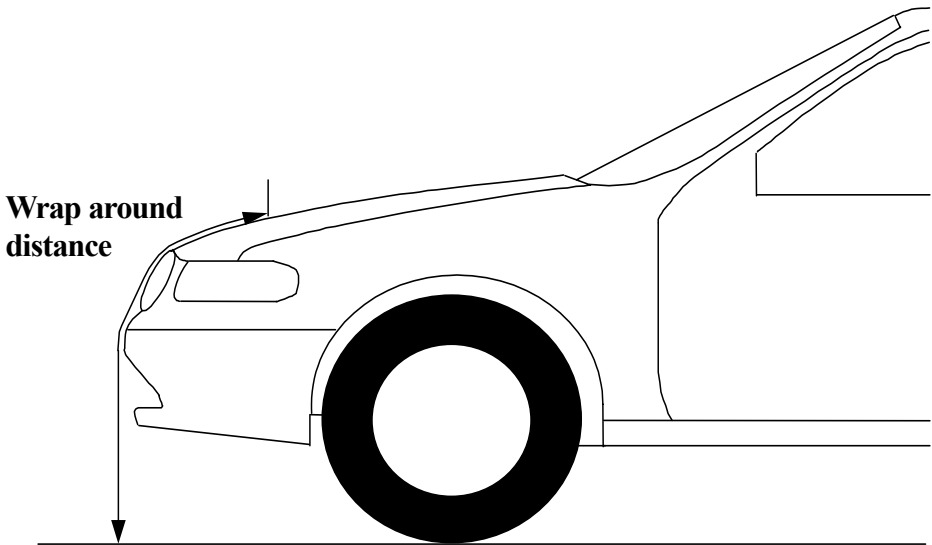

Figure 11: Wrap around distance measurement (see paragraph 3.29.)

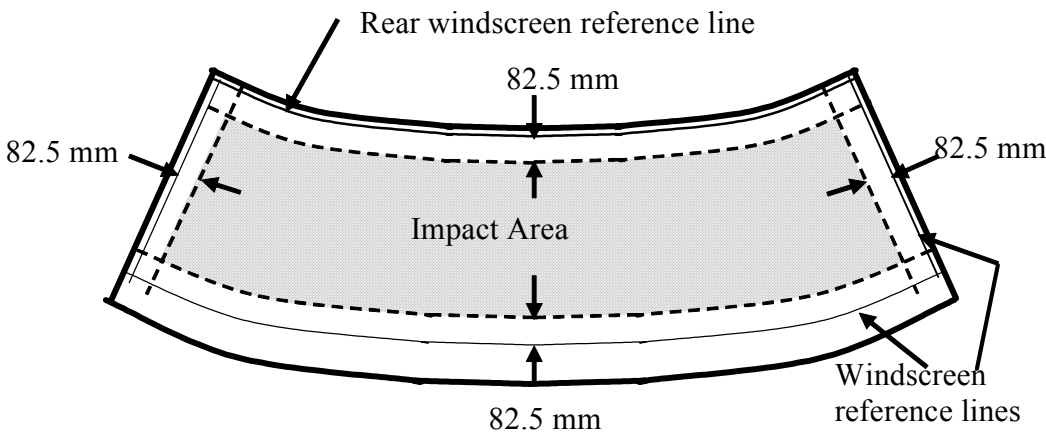

Figure 12: Windscreen test area (see paragraph 3.34.)

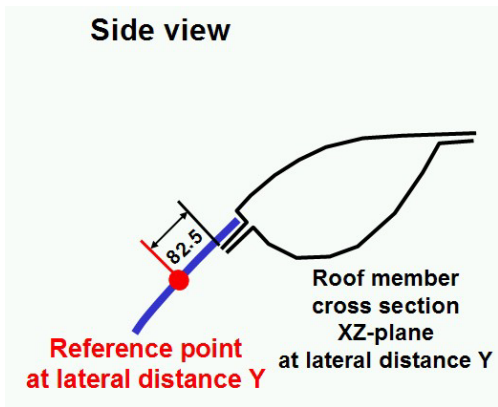

Figure 13a: Windscreen rear reference line (see paragraph 3.33.)

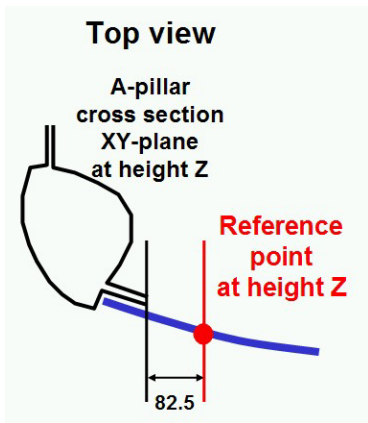

Figure 13b: Windscreen side reference line (see paragraph 3.32.)

Figure to be created

Figure 13c: Windscreen lower reference line (see paragraph 3.31.)

4. GENERAL REQUIREMENTS

This global technical regulation specifies the following tests to verify compliance of vehicles.

4.1. Legform test to bumper:

~~[For vehicles with a lower bumper height of less than 425 mm the requirements of paragraph 4.1.1. shall be applied.]~~

~~[For vehicles with a lower bumper height which is both greater than, or equal to, 425 mm and less than 500 mm the requirements of either paragraph 4.1.1.1 or 4.1.2., as agreed by the manufacturer, shall apply]~~

~~[For vehicles with a lower bumper height of greater than 500 mm the requirements of paragraph 4.1.2. shall be applied.]~~

~~[One of the following legform tests will be required to be performed:]~~

4.1.1. Lower legform to bumper:

To verify ~~[the-]~~compliance with the performance requirements as specified in paragraph 5.1.1., both the test impactor specified in paragraph 6.3.1.1. and the test procedures specified in paragraph 7.1.1. shall be used

4.1.2. Upper legform to bumper:

To verify ~~[the-]~~compliance with the performance requirements as specified in paragraph 5.1.2., both the test impactor specified in paragraph 6.3.1.2. and the test procedures specified in paragraph 7.1.2. shall be used.

4.2. Child headform impact:

To verify ~~[the-]~~compliance with the performance requirements as specified in paragraphs 5.2.1. and 5.2.3., both the test impactor specified in paragraph 6.3.2.1. and the test procedures specified in paragraphs 7.2 and 7.3. shall be used.

4.3. Adult headform impact:

To verify ~~[the-]~~compliance with the performance requirements as specified in paragraphs 5.2.2. and 5.2.3., both the test impactor specified in paragraph 6.3.2.2. and the test procedures specified in paragraphs 7.2. and 7.4. shall be used.

5. PERFORMANCE REQUIREMENTS

5.1. Legform to Bumper:

- 5.1.1. When tested in accordance with paragraph 7.1.1. (lower legform to bumper), the maximum dynamic knee bending angle shall not exceed 19°, the maximum dynamic knee shearing displacement shall not exceed 6.0 mm, and the acceleration measured at the upper end of the tibia shall not exceed 170 g. [In addition the manufacturer may nominate bumper test widths up to 264 mm in total where the acceleration measured at the upper end of the tibia shall not exceed ~~[200]~~~~[250]~~ g.]

5.1.2. When tested in accordance with paragraph 7.1.2. (upper legform to bumper), the instantaneous sum of the impact forces with respect to time shall not exceed ~~[6.25][7.5]~~ kN and the bending moment on the test impactor shall not exceed ~~[375][510]~~ Nm.

[In addition the manufacturer may nominate bumper test widths up to 264 mm in total where the instantaneous sum of the impact forces with respect to time shall not exceed 7.5 kN and the bending moment on the test impactor shall not exceed 510 Nm.]

5.2. Headform tests

5.2.1. Child headform to front structure:

When tested in accordance with paragraph 7.3. ~~[for all tests, together with the tests according to paragraph 5.2.2,]~~ the ~~[HPC][HIC]~~ shall ~~[comply with paragraph 5.2.3.]~~~~[not exceed 1000 over [2/3] of the bonnet test area and [1700] for the remaining [1/3] [of the bonnet test area]].~~ For impact points in the windscreen test area, the requirements of paragraph 5.2.4. shall apply.

5.2.2. Adult headform to the front structure:

When tested in accordance with paragraph 7.4. [for all tests , together with the tests according to paragraph 5.2.1,] the HIC shall not exceed 1000 over [2/3] of the bonnet test area and [1700] for the remaining [1/3] [of the bonnet test area]. For impact points in the windscreen test area, the requirements of paragraph 5.2.3. shall apply.

5.2.3. The [HPC recorded shall not exceed 1000 over one half of the child headform test area and , in addition, shall not exceed 1000 over 2/3 of the combined child and adult headform test areas. The HPC for the remaining areas shall not exceed 1700 for both headforms.]~~[HIC shall not exceed [1000] for any selected impact points within the windscreen test area as defined in paragraph 3.33.]~~

[5.2.4. Splitting of headform test zone

5.2.4.1. The manufacturer shall identify the zones of the bonnet top where the HPC must not exceed 1000 (HPC1000 Zone) respectively [1700] (HPC 1700 Zone) (see Figure 20).

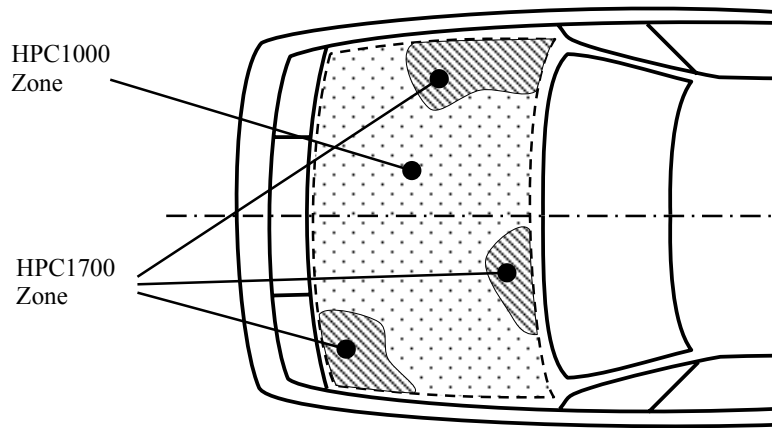

Figure 20: Marking of HPC1000 zone and HPC1700 zone

5.2.4.2. Marking of the “Bonnet Top” impact area as well as “HPC1000 Zone” and “HPC1700 Zone” will be based on a drawing supplied by the manufacturer, when viewed from a horizontal plane above the vehicle that is parallel to the vehicle horizontal zero plane. A sufficient number of x and y co-ordinates shall be supplied by the manufacturer to mark up the areas on the actual vehicle while considering the vehicle outer contour in the z direction.

5.2.4.3. The areas of “HPC1000 Zone” and “HPC1700 Zone” may consist of several parts, with the number of these parts not being limited.

5.2.4.4. The calculation of the surface of the impact area as well as the surface areas of “HPC1000 Zone” and “HPC1700 Zone” shall be done on the basis of a projected bonnet when viewed from a horizontal plane parallel to the horizontal zero plane above the vehicle, on the basis of the drawing data supplied by the manufacturer.

5.2.5. The HPC shall not exceed [1000] for any selected impact points within the windscreen test area.]

6. TEST SPECIFICATIONS

6.1. General test conditions

6.1.1. Temperature and humidity

The stabilised temperature of the test tools and of the vehicle or sub-system at the time of testing shall be $20^{\circ} \pm 4^{\circ}\text{C}$.

The relative humidity of [a controlled storage]~~[the test]~~ area where [all test impactors are]~~[all equipment is]~~ stored should be [10 to 70]~~[40 per cent \pm 30]~~ per cent after a stabilised period of at least four hours prior to [removal for use in]~~[the application of]~~ any test.

[Each test shall be completed within two hours of when the impactor to be used is removed from the controlled storage area.]

Relative humidity and temperature [of the test area] shall be measured at the time of the test, and recorded in the test report.

6.1.2. Impact test site

The test site shall consist of a flat, smooth and hard surface with a slope not exceeding 1 per cent.

6.2. Preparation of the vehicle

6.2.1. Either a complete vehicle, or a cut-body, adjusted to the following conditions shall be used for the test.

6.2.1.1. The vehicle shall be in its normal ride attitude, ~~[as described in paragraph 3.20.,]~~ and shall be either securely mounted on raised supports or at rest on a flat [horizontal] surface ~~[with the].~~ The parking brake ~~[shall be]~~ applied ~~[, or the cut body shall be securely mounted].~~

6.2.1.2. The cut-body shall include [, in the test,] all parts of the vehicle front structure [, all] ~~[—and]~~ under-bonnet components [and all components] ~~[,—or]~~ behind [the] windscreen ~~[—components]~~, that may be involved in a frontal impact with a vulnerable road user ~~[in the test]~~, to demonstrate the performance and interactions of all the contributory vehicle components.

The cut-body shall be securely mounted in the normal vehicle ride attitude.

6.2.2. All devices designed to protect vulnerable road users when impacted by the vehicle shall be correctly activated before and/or be active during the appropriate test. ~~[An example of a typical procedure is described in Annex 1.]~~ It shall be the responsibility of the manufacturer to show that any devices will act as intended in a pedestrian impact.

6.2.3. For vehicle components which could change shape or position, other than active devices to protect pedestrians, [and which] ~~[where such devices]~~ have more than one fixed [shape or] position [shall require] the vehicle [to] ~~[shall]~~ comply with [the components in each fixed shape or position] ~~[all requirements for all of these positions].~~
~~[Where such devices have only one fixed position, only the fixed position shall be considered.]~~

6.2.4. If the vehicle is fitted with a badge, mascot or other structure which would bend back or retract under a low applied load, then such a load shall be applied before and/or while the test requirements are completed.

[6.2.5. All standard equipment normally fitted to the front end of the vehicle shall be in position.]

6.3. Test impactor specifications

6.3.1. Legform impactors:

6.3.1.1. Lower legform impactor:

The lower legform impactor shall consist of two foam covered rigid segments, representing femur (upper leg) and tibia (lower leg), joined by a deformable, simulated knee joint. The overall length of the impactor shall be 926 ± 5 mm, having a required test mass of 13.4 ± 0.2 kg (see Figure 14).

Brackets, pulleys, etc. attached to the impactor for the purpose of launching it, may extend the dimensions shown in Figure 14.

6.3.1.1.1. The diameter of the femur and tibia shall be 70 ± 1 mm and both shall be covered by foam flesh and skin. The foam flesh shall be 25 mm thick Confor™ foam type CF-45 or equivalent. The skin shall be made of neoprene foam, faced with 0.5 mm thick nylon cloth both sides, with an overall thickness of 6 mm.

6.3.1.1.2. The centre of the knee is defined as the point about which the knee effectively bends.

6.3.1.1.3. The knee joint shall be fitted with deformable knee elements from the same batch as those used in the certification tests.

6.3.1.1.4. The "femur" is defined as all components or parts of components (including flesh, skin covering, damper, instrumentation and brackets, pulleys, etc. attached to the impactor for the purpose of launching it) above the level of the centre of the knee.

6.3.1.1.5. The "tibia" is defined as all components or parts of components (including flesh, skin covering, instrumentation and brackets, pulleys, etc. attached to the impactor for the purpose of launching it) below the level of the centre of the knee. Note that the tibia as defined includes allowances for the mass, etc., of the foot.

6.3.1.1.6. The total masses of the femur and tibia shall be 8.6 ± 0.1 kg and 4.8 ± 0.1 kg respectively, and the total mass of the impactor shall be 13.4 ± 0.2 kg. The centre of gravity of the femur and tibia shall be 217 ± 10 mm and 233 ± 10 mm from the centre of the knee respectively. The moment of inertia of the femur and tibia, about a horizontal axis through the respective centre of gravity and perpendicular to the direction of impact, shall be 0.127 ± 0.010 kgm² and 0.120 ± 0.010 kgm² respectively.

6.3.1.1.7. The impactor shall be fitted with foam flesh cut from one of up to four consecutive sheets of Confor™ foam flesh material or equivalent, produced from the same batch of manufacture (cut from one block or 'bun' of foam), provided that foam from one of these sheets was used in the dynamic certification test and the individual weights of these sheets are within ± 2 per cent of the weight of the sheet used in the certification test.

6.3.1.1.8. Lower legform instrumentation

6.3.1.1.8.1. A uniaxial accelerometer shall be mounted on the non-impacted side of the tibia, 66 ± 5 mm below the knee joint centre, with its sensitive axis in the direction of impact.

~~[6.3.1.1.8.2.—The impactor shall be instrumented to measure the bending angle and the shearing displacement between femur and tibia.]~~

6.3.1.1.8.32. A damper shall be fitted to the shear displacement system and may be mounted at any point on the rear face of the impactor or internally. The damper properties shall be such that the impactor meets both the static and dynamic shear displacement requirements and prevents excessive vibrations of the shear displacement system.

6.3.1.1.8.43. Transducers shall be fitted to measure knee bending angle and knee shearing displacement.

6.3.1.1.8.54. The instrumentation response value CFC, as defined in ISO 6487:2002, shall be 180 for all transducers. The CAC response values, as defined in ISO 6487:2002, shall be 50° for the knee bending angle, 10 mm for the shearing displacement and 500 g for the acceleration. This does not require that the impactor itself be able to physically bend and shear to these angles and displacements.

6.3.1.1.9. Lower legform certification

6.3.1.1.9.1. The lower legform impactor shall meet the performance requirements specified in paragraph 8.

6.3.1.1.9.2. The certified impactor may be used for a maximum of 20 impacts before re-certification. With each test new plastically deformable knee elements should be used. The impactor shall also be re-certified if more than one year has elapsed since the previous certification, if any impactor transducer output, in any impact, has exceeded the specified CAC or has reached the mechanical limits of the leg impactor deformation capability.

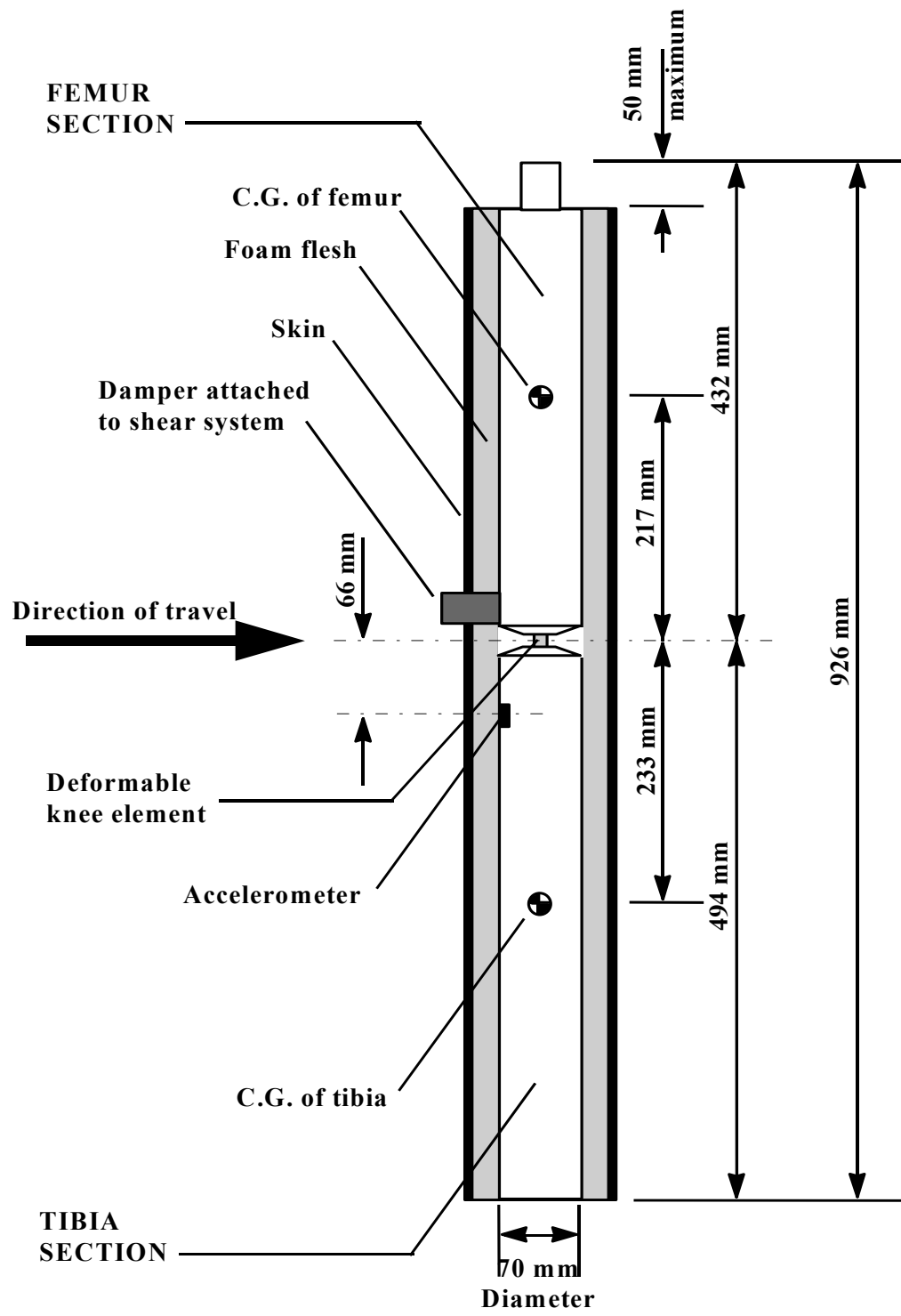

Figure 14: Lower legform impactor. (see paragraph 6.3.1.1.)

6.3.1.2. Upper legform impactor:

The upper legform impactor shall be rigid, foam covered at the impact side, and 350 ± 5 mm long (see Figure 15).

6.3.1.2.1. The total mass of the upper legform impactor including those propulsion and guidance components which are effectively part of the impactor during the impact shall be $9.5 \text{ kg} \pm 0.1 \text{ kg}$.

6.3.1.2.2. The total mass of the front member and other components in front of the load transducer assemblies, together with those parts of the load transducer assemblies in front of the active elements, but excluding the foam and skin, shall be $1.95 \pm 0.05 \text{ kg}$.

6.3.1.2.3. The upper legform impactor for the bumper test shall be mounted to the propulsion system, by a torque-limiting joint, to prevent large off centre loads damaging the guidance system. The guidance system shall be fitted with low friction guides, insensitive to off-axis loading, that allow the impactor to move only in the specified direction of impact, when in contact with the vehicle. The guides shall prevent motion in other directions including rotation about any axis.]

6.3.1.2.~~34~~. The torque limiting joint shall be set so that the longitudinal axis of the front member is perpendicular to the axis of the guidance system, with a tolerance of $\pm 2^\circ$, with the joint friction torque set to $675 \text{ Nm} \pm 25 \text{ Nm}$.

6.3.1.2.~~45~~. The centre of gravity of those parts of the impactor which are effectively forward of the torque limiting joint, including any weights fitted, shall lie on the longitudinal centre line of the impactor, with a tolerance of $\pm 10 \text{ mm}$.

6.3.1.2.~~56~~. The length between the load transducer centre lines shall be $310 \pm 1 \text{ mm}$ and the front member diameter shall be $50 \pm 1 \text{ mm}$.

6.3.1.2.~~67~~. The foam flesh shall be two sheets of 25 mm thick Confor™ foam type CF-45 or equivalent[, and shall be cut from the sheet of material used for the dynamic certification test.]. The skin shall be a 1.5 mm thick fibre reinforced rubber sheet. The foam and rubber skin together shall weigh $0.6 \pm 0.1 \text{ kg}$ (this excludes any reinforcement, mountings, etc. which are used to attach the rear edges of the rubber skin to the rear member). The foam and rubber skin shall be folded back towards the rear, with the rubber skin attached via spacers to the rear member so that the sides of the rubber skin are held parallel. The foam shall be of such a size and shape that an adequate gap is maintained between the foam and components behind the front member, to avoid significant load paths between the foam and these components.

6.3.1.2.78. Upper legform instrumentation

6.3.1.2.78.1. The front member shall be strain gauged to measure bending moments in three positions, as shown in Figure 15, each using a separate channel. The strain gauges are located on the impactor on the back of the front member. The two outer strain gauges are located 50 ± 1 mm from the impactor's symmetrical axis. The middle strain gauge is located on the symmetrical axis with a ± 1 mm tolerance.

6.3.1.2.78.2. Two load transducers shall be fitted to measure individually the forces applied at either end of the upper legform impactor, plus strain gauges measuring bending moments at the centre of the upper legform impactor and at positions 50 mm either side of the centre line, (see Figure 15).

6.3.1.2.78.3. The instrumentation response value CFC, as defined in ISO 6487:2002, shall be 180 for all transducers. The CAC response values, as defined in ISO 6487:2002, shall be 10 kN for the force transducers and 1000 Nm for the bending moment measurements.

6.3.1.2.89. Upper legform certification

6.3.1.2.89.1. The upper legform impactor shall meet the performance requirements specified in paragraph 8.

6.3.1.2.89.2. The certified impactor may be used for a maximum of 20 impacts before re-certification (this limit does not apply to propulsion or guidance components). The impactor shall also be re-certified if more than one year has elapsed since the previous certification or if any impactor transducer output, in any impact, has exceeded the specified CAC.

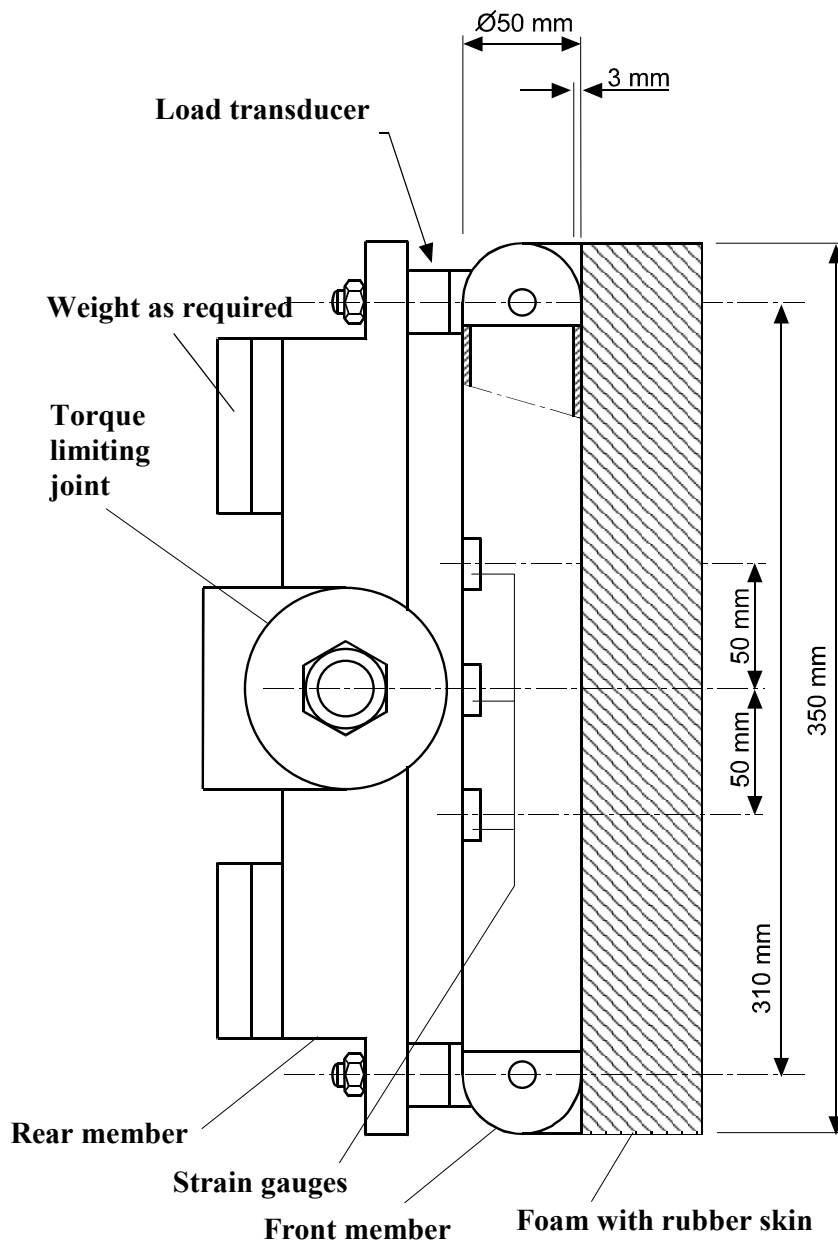

Figure 15: Upper legform impactor (see paragraph 6.3.1.2.)

6.3.2. Child and adult headform impactors

6.3.2.1. Child headform impactor (see Figure 16)

The child headform impactor shall be made of aluminium, be of homogenous construction and be of spherical shape. The overall diameter shall be 165 ± 1 mm. The mass shall be 3.5 ± 0.07 kg. The moment of inertia about an axis through the centre of gravity and perpendicular to the direction of impact shall be within the range of $[0.0080$ to $0.0120]$ kgm^2 . The centre of gravity of the headform impactor including

instrumentation shall be located in the geometric centre of the sphere with a tolerance of ± 2 mm.

The sphere shall be covered with a 14 ± 0.5 mm thick synthetic skin, which shall cover at least half of the sphere.

6.3.2.1.1. Child headform instrumentation

A recess in the sphere shall allow for mounting one triaxial or three uniaxial accelerometers within ± 10 mm seismic mass location tolerance from the centre of the sphere for the measurement axis, and ± 1 mm seismic mass location tolerance from the centre of the sphere for the perpendicular direction to the measurement axis.

If three uniaxial accelerometers are used, one of the accelerometers shall have its sensitive axis perpendicular to the mounting face A (see figure 16) and its seismic mass shall be positioned within a cylindrical tolerance field of 1 mm radius and 20mm length. The centre line of the tolerance field shall run perpendicular to the mounting face and its mid-point shall coincide with the centre of the sphere of the headform impactor.

The remaining accelerometers shall have their sensitive axes perpendicular to each other and parallel to the mounting face A and their seismic mass shall be positioned within a spherical tolerance field of 10 mm radius. The centre of the tolerance field shall coincide with the centre of the sphere of the headform impactor.

The instrumentation response value CFC, as defined in ISO 6487: 2002, shall be 1,000. The CAC response value, as defined in ISO 6487: 2002, shall be 500 g for the acceleration.

6.3.2.1.2. First natural frequency

The first natural frequency of the headform impactor shall be over 5000 Hz.

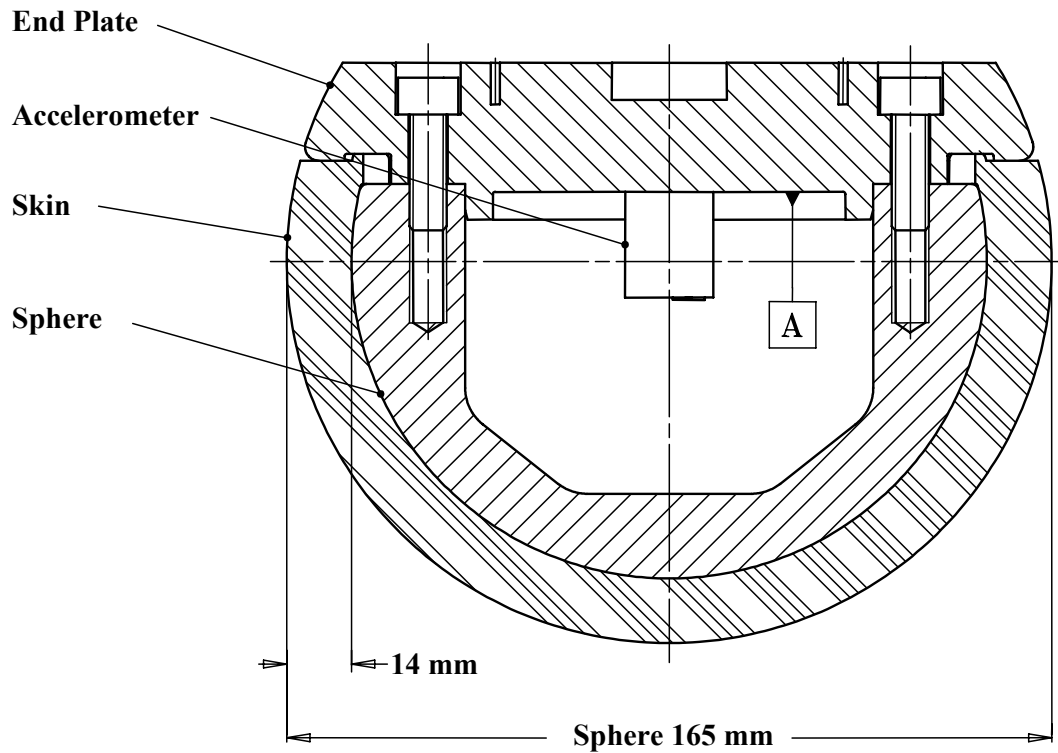

Figure 16: Child headform impactor (see paragraph 6.3.2.1.)

6.3.2.2. Adult headform impactor (see Figure 17)

The adult headform impactor shall be made of aluminium, be of homogenous construction and be of spherical shape. The overall diameter is 165 ± 1 mm as shown in Figure 17. The mass shall be 4.5 ± 0.1 kg. The moment of inertia about an axis through the centre of gravity and perpendicular to the direction of impact shall be within the range of $[0.0075 \text{ to } 0.0200] \text{ kgm}^2$. The centre of gravity of the headform impactor including instrumentation shall be located in the geometric centre of the sphere with a tolerance of ± 5 mm.

The sphere shall be covered with a 14 ± 0.5 mm thick synthetic skin, which shall cover at least half of the sphere.

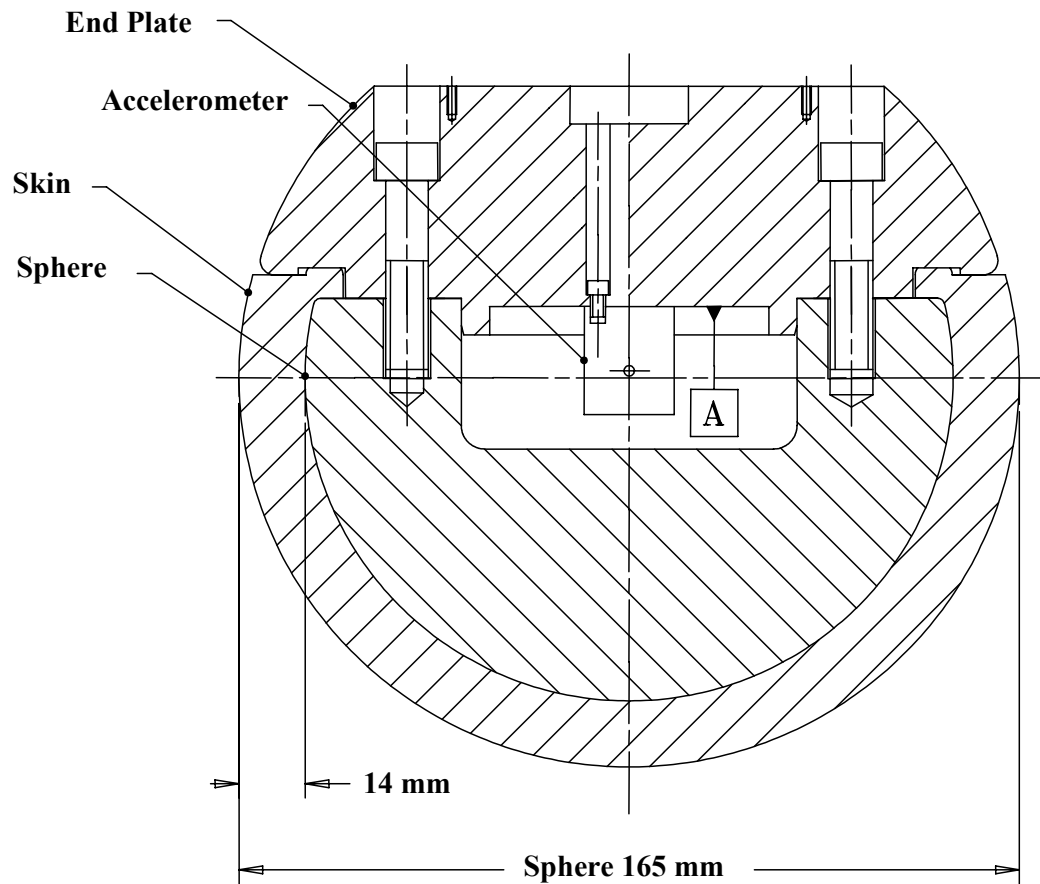

Figure 17: Adult headform impactor (see paragraph 6.3.2.2)

6.3.2.2.1. Adult headform instrumentation

A recess in the sphere shall allow for mounting one triaxial or three uniaxial accelerometers within ± 10 mm seismic mass location tolerance from the centre of the sphere for the measurement axis, and ± 1 mm seismic mass location tolerance from the centre of the sphere for the perpendicular direction to the measurement axis.

If three uniaxial accelerometers are used, one of the accelerometers shall have its sensitive axis perpendicular to the mounting face A (see figure 17) and its seismic mass shall be positioned within a cylindrical tolerance field of 1 mm radius and 20 mm length. The centre line of the tolerance field shall run perpendicular to the mounting face and its mid-point shall coincide with the centre of the sphere of the headform impactor.

The remaining accelerometers shall have their sensitive axes perpendicular to each other and parallel to the mounting face A and their seismic mass shall be positioned within a spherical tolerance field of 10 mm radius. The centre of the tolerance field shall coincide with the centre of the sphere of the headform impactor.

The instrumentation response value CFC, as defined in ISO 6487: 2002, shall be 1000. The CAC response value, as defined in ISO 6487: 2002, shall be 500 g for the acceleration.

6.3.2.2.2. First natural frequency

First natural frequency of the headform impactors shall be over 5000 Hz.

6.3.2.3. Rear face of the headform impactors

A rear flat face shall be provided on the outer surface of the headform impactors which is perpendicular to the direction of travel, and typically perpendicular to the axis of one of the accelerometers as well as being a flat plate capable of providing for access to the accelerometers and an attachment point for the propulsion system.

6.3.2.4. Certification of the headform impactors

The headform impactors shall meet the performance requirements specified in paragraph 8. The certified impactors may be used for a maximum of 20 impacts before re-certification. The impactors shall be re-certified if more than one year has elapsed since the previous certification or if the transducer output, in any impact, has exceeded the specified CAC.

7. TEST PROCEDURES

[Refer to Annex 2 for impactor handling procedures]

7.1. Legform to Bumper Test Procedures

7.1.1. Lower legform to bumper test procedure:

7.1.1.1. The selected target points shall be in the bumper test area ~~[as defined in paragraph 3-10]~~ and shall be a minimum of 132 mm apart. The minimum distance is to be set with a flexible tape held tautly along the outer surface of the vehicle]. The positions tested shall be indicated in the test report.

7.1.1.2. The direction of the impact velocity vector shall be in the horizontal plane and parallel to the longitudinal vertical plane of the vehicle. The tolerance for the direction of the velocity vector in the horizontal plane and in the longitudinal plane shall be $\pm 2^\circ$ at the time of first contact. The axis of the impactor shall be perpendicular to the horizontal plane with a tolerance of $\pm 2^\circ$ in the lateral and longitudinal plane. The horizontal, longitudinal and lateral planes are orthogonal to each other (see Figure 18).

7.1.1.3. The bottom of the impactor shall be at 25 mm above ground reference level at the

time of first contact with the bumper (see Figure 19), with a ± 10 mm tolerance. When setting the height of the propulsion system, an allowance must be made for the influence of gravity during the period of free flight of the impactor.

7.1.1.3.1. The lower legform impactor for the bumper tests shall be in 'free flight' at the moment of impact. The impactor shall be released to free flight at such a distance from the vehicle that the test results are not influenced by contact of the impactor with the propulsion system during rebound of the impactor.

The impactor may be propelled by an air, spring or hydraulic gun, or by other means that can be shown to give the same result.

7.1.1.3.2. At the time of first contact the impactor shall have the intended orientation about its vertical axis, for the correct operation of its knee joint, with a tolerance of $\pm 5^\circ$ (see Figure 18).

7.1.1.3.3. At the time of first contact the centre line of the impactor shall be within a ± 10 mm tolerance to the selected impact location.

7.1.1.3.4. During contact between the impactor and the vehicle, the impactor shall not contact the ground or any object which is not part of the vehicle.

7.1.1.4. The impact velocity of the impactor when striking the bumper shall be 11.1 ± 0.2 m/s. The effect of gravity shall be taken into account when the impact velocity is obtained from measurements taken before the time of first contact.

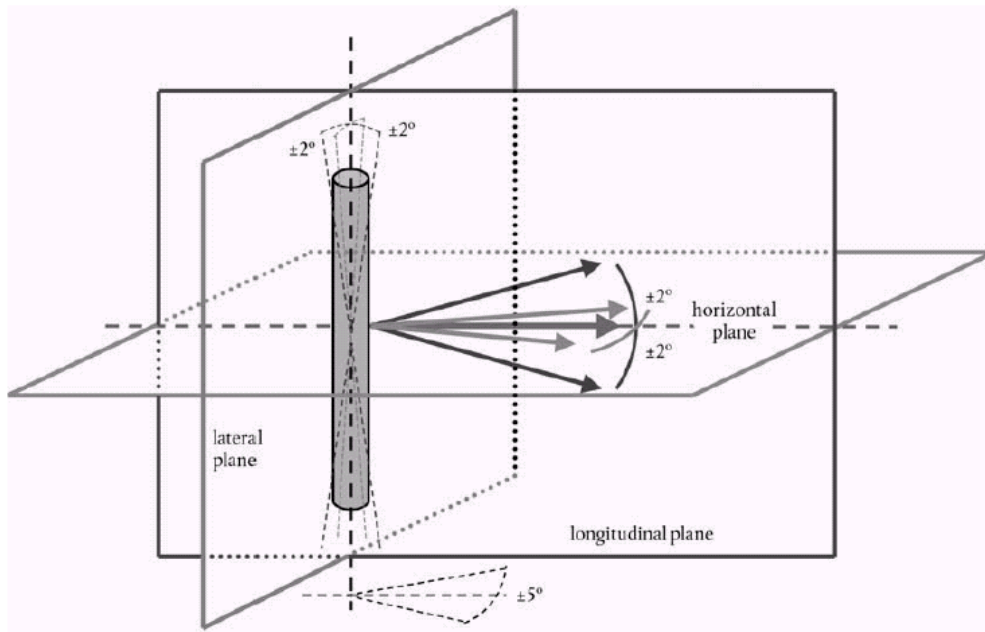

Figure 18: Tolerances of angles for the lower legform impactor at the time of first impact (see paragraphs 7.1.1.2 and 7.1.1.3.2.)

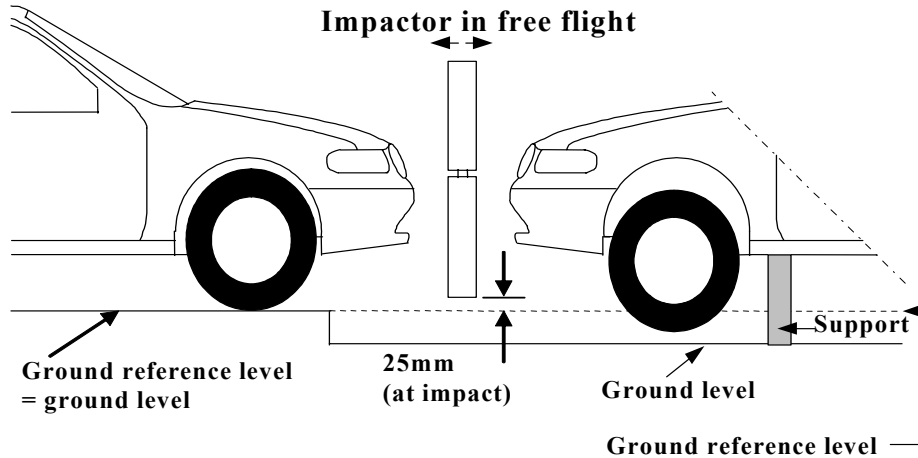

Figure 19: Lower legform to bumper tests for complete vehicle in normal ride attitude (left) and for cut-body mounted on supports (right) (see paragraph 7.1.1.3)

7.1.2. Upper legform to bumper test procedure:

7.1.2.1. ~~[If the lower bumper height at the test position is more than 500 mm and the manufacturer elects to perform an upper legform test instead of a lower legform test],~~ [The][the] selected target points shall be in the bumper test area as defined in paragraph 3.10 [and shall be a minimum of 132 mm apart. The minimum distance is to be set with a flexible tape held tautly along the outer surface of the vehicle]. The positions tested shall be indicated in the test report.

7.1.2.2. The direction of impact shall be parallel to the longitudinal axis of the vehicle, with the axis of the upper legform vertical at the time of first contact. The tolerance to this direction is $\pm 2^\circ$.

At the time of first contact the impactor centre line shall be vertically midway between the upper bumper reference line and the lower bumper reference line with a ± 10 mm tolerance and laterally with the selected impact location with a tolerance of ± 10 mm.

7.1.2.3. The impact velocity of the upper legform impactor when striking the bumper shall be 11.1 ± 0.2 m/s.

7.2. Headform Test Procedures

7.2.1. Propulsion of the headform impactors

The headform impactors shall be in "free flight" at the moment of impact, at the required impact velocity (see paragraphs 7.3.5. and 7.4.5.) and the required direction of impact (see paragraphs 7.3.6. and 7.4.6.).

The impactors shall be released to free flight at such a distance from the vehicle that the test results are not influenced by contact of the impactor with the propulsion system during rebound of the impactor.

7.2.2. Measurement of impact velocity

The velocity of the headform impactor shall be measured at some point during the free flight before impact, in accordance with the method specified in ISO 3784:1976 (ISO number to be checked). The accuracy of velocity measurement shall be ± 0.01 m/sec. The measured velocity shall be adjusted considering all factors which may affect the impactor between the point of measurement and the point of impact, in order to give the velocity of the impactor at the time of impact. The angle of the velocity vector at the time of impact shall be calculated or measured.

7.2.3. Recording

The acceleration time histories shall be recorded, and [HPC][HIC] shall be calculated. The first point of contact on the front structure of the vehicle shall be recorded. Recording of test results shall be in accordance with ISO 6487:2002.

~~7.2.4 “Bonnet Top Zone A” and “Bonnet Top Zone B”~~

~~7.2.4.1 The manufacturer shall identify the zones of the bonnet top where the Head Performance Criterion (HPC) must not exceed 1000 (Bonnet Top Zone A) respectively [1700] (Bonnet Top Zone B), according to the technical requirements set out in paragraph 5.2 (see Figure 20).~~

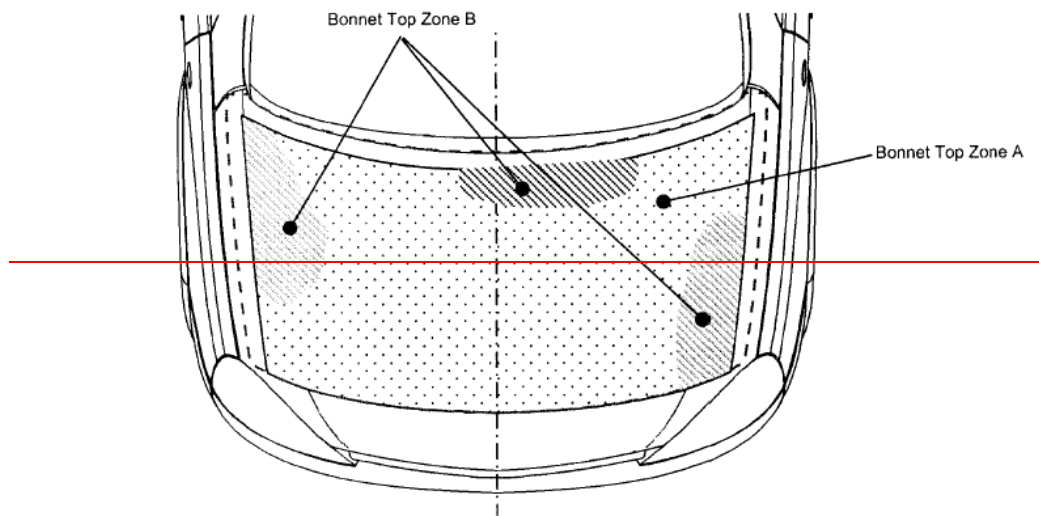

~~Figure 20: Bonnet Top Zone A and Bonnet Top Zone B~~

~~7.2.4.2 Marking of the “Bonnet Top” impact area as well as “Bonnet Top Zone A” and “Bonnet Top Zone B” will be based on a drawing supplied by the manufacturer, when viewed from a horizontal plane above the vehicle that is parallel to the vehicle horizontal zero plane. A sufficient number of x and y co ordinates shall be supplied by the~~

~~manufacturer to mark up the areas on the actual vehicle while considering the vehicle outer contour in the z direction.~~

~~7.2.4.3 The areas of “Bonnet Top Zone A” and “Bonnet Top Zone B” may consist of several parts, with the number of these parts not being limited.~~

~~7.2.4.4 The calculation of the surface of the impact area as well as the surface areas of “Bonnet Top Zone A” and “Bonnet Top Zone B” shall be done on the basis of a projected bonnet when viewed from a horizontal plane parallel to the horizontal zero plane above the vehicle, on the basis of the drawing data supplied by the manufacturer.]~~

7.3. Child headform test procedure:

This test procedure is applicable with respect to the requirements of paragraph 5.2.1. and 5.2.3. of this gtr.

7.3.1. Tests shall be made to the front structure within the boundaries as defined in paragraph 3.11. For tests on the rear area of the bonnet top, the headform impactor shall not contact the windscreen or A-pillar before impacting the bonnet top.

7.3.32. No impact point shall be located so that the impactor will impact the test area with a glancing blow resulting in a more severe second impact.

Selected impact points on the bonnet for the child headform impactor shall, at the time of first contact:

- ~~[- be a minimum of 165 mm apart, and]~~
- ~~- be a minimum of 82.5 mm inside the defined bonnet side reference lines, [and][as defined in paragraph 3.22.]~~
- ~~- be forward of the WAD1700 line [as defined in paragraph 3.29,] or a minimum of 82.5 mm forward of the bonnet rear reference line [as defined in paragraph 3.6,] whichever is most forward [at the point of measurement, and,]~~
- ~~- be [rearward of the WAD1000 line or] a minimum of [82.5][165] mm rearwards of the bonnet leading edge reference line, [whichever is most rearward at the point of measurement][as defined in paragraph 3.5].~~

If the WAD1700 line is located, at any point, in the windscreen test area ~~[as defined in paragraph 3.34.]~~ impact points selected on the windscreen test area for the child headform impactor shall, at time of first contact:

- ~~- be forward of the WAD1700 line or a minimum of 82.5 mm forwards of the windscreen rear reference line, [as defined in paragraph 3.33,] whichever is most forward.~~

~~[If the WAD1700 line is located, at any point, rearward of the windscreen rear reference line as defined in paragraph 3.33, impact points selected on the windscreen area for the child head form impactor shall, at time of first contact:~~

- ~~- be a minimum of 82.5 mm forward of the windscreen rear reference line]~~

7.3.32.1. These minimum distances are to be set with a flexible tape held tautly along the outer surface of the vehicle.

- 7.3.32.2. The points selected for testing shall be indicated in the test report.
- 7.3.43. The point of first contact of the headform impactor shall be within a ± 10 mm tolerance to the selected impact point.
- 7.3.54. The headform velocity at the time of impact shall be 9.7 ± 0.2 m/s.
- 7.3.65. The direction of impact shall be as specified as follows:
The direction of impact shall be in the longitudinal vertical plane of the vehicle to be tested at an angle of 50° to the horizontal [The situation of windscreen is to be confirmed prior to the next meeting]. The tolerance for this direction is $\pm 2^\circ$. The direction of impact of tests to the front structure shall be downward and rearward.

7.4. Adult headform test procedure:

This test procedure is applicable with respect to the requirements of paragraph 5.2.2. and 5.2.3. of the performance requirements of this Regulation.

- 7.4.1. Tests shall be made to the front structure within the boundaries as defined in paragraph 3.1. For tests at the rear of the bonnet top, the headform impactor shall not contact the windscreen or A-pillar before impacting the bonnet top.

- 7.4.32. No impact point shall be located so that the impactor will impact the test area with a glancing blow resulting in a more severe second impact.

Selected impact points on the bonnet for the adult headform impactor shall, at the time of first contact:

- [~~- be a minimum of 165 mm apart, and~~
- be a minimum of 82.5 mm inside the defined bonnet side reference lines, ~~[and] [as defined in paragraph 3.22.];~~
- be forward of the WAD2100 line or a minimum of 82.5 mm forward of the bonnet rear reference line, ~~[as defined in paragraph 3.6.],~~ whichever is most forward, ~~[, and.]~~
- [~~- be rearward of the WAD1700 line.]~~

If the rear reference line for adult headform as ~~[defined in paragraph 3.21.]~~ is located, at any point, in the windscreen test area ~~[as defined in paragraph 3.34.]~~ impact points selected on the windscreen test area for the adult headform impactor shall, at time of first contact:

- be forward of the rear reference line for adult headform or a minimum of 82.5 mm forward of the windscreen rear reference line ~~[as defined in paragraph 3.33.],~~ whichever is most forward;
- be rearward of the WAD1700 line or a minimum of 82.5 mm rearwards of the windscreen lower reference line, ~~[as defined in paragraph 3.31.],~~ whichever is most rearward.

~~[If the rear reference line for adult head form as defined in paragraph 3.21 is located, at any point, rearward of the windscreen rear reference line as defined in paragraph 3.33, impact points selected on the windscreen area for the adult head form impactor shall, at time of first contact:~~

- ~~- be a minimum of 82.5 mm forward of the windscreen rear reference line~~

- ~~be rearward of the WAD1700 line or a minimum of 82.5 mm rearwards of the windscreen lower reference line, as defined in paragraph 3.31, whichever is most rearward.]~~

7.4.3.1. These minimum distances are to be set with a flexible tape held tautly along the outer surface of the vehicle.

7.4.3.2. The points selected for testing shall be indicated in the test report.

7.4.4. The point of first contact of the headform impactor shall be within a ± 10 mm tolerance to the selected impact point.

7.4.5. The headform velocity at the time of impact shall be 9.7 ± 0.2 m/s.

7.4.6. The direction of impact shall be as specified as follows:

The direction of impact shall be in the fore and aft vertical plane of the paragraph of the vehicle to be tested at an angle of 65° to the horizontal [The situation of windscreen is to be confirmed prior to the next meeting].. The tolerance for this direction is $\pm 2^\circ$. The direction of impact of tests to the front structure shall be downward and rearward.

8. CERTIFICATION OF IMPACTORS

The impactors that are used in the tests described in this gtr are required to comply with ~~[the following][appropriate]~~ performance requirements.

The requirements for the lower legform impactor are specified in paragraph 8.1., the upper legform impactor requirements are specified in paragraph 8.2. and the adult and child headform impactors requirements are specified in paragraph 8.3.

8.1. Lower legform impactor certification

8.1.1. Static tests

8.1.1.1. The lower legform impactor shall meet the requirements specified in paragraph 8.1.1.2. when tested as specified in paragraph 8.1.1.4. and the impactor shall meet the requirements specified in paragraph 8.1.1.3. when tested as specified in paragraph 8.1.1.5.

For both tests the impactor shall have the intended orientation about its longitudinal axis, for the correct operation of its knee joint, with a tolerance of $\pm 2^\circ$.

The stabilised temperature of the impactor during certification shall be $20 \pm 2^\circ\text{C}$.

The CAC response values, as defined in ISO 6487:2002 shall be 50° for the knee bending angle and 500 N for the applied force when the impactor is loaded in bending in accordance with paragraph 8.1.1.4., and 10 mm for the shearing displacement and 10 kN for the applied force when the impactor is loaded in shearing in accordance with paragraph 8.1.1.5. For both tests low-pass filtering at an appropriate frequency is

permitted, to remove higher frequency noise without significantly affecting the measurement of the response of the impactor.

8.1.1.2. When the impactor is loaded in bending in accordance with paragraph 8.1.1.4., the applied force/bending angle response shall be within the limits shown in Figure 21. Also, the energy taken to generate 15.0° of bending shall be 100 ± 7 J.

8.1.1.3. When the impactor is loaded in shearing in accordance with paragraph 8.1.1.5., the applied force/shearing displacement response shall be within the limits shown in Figure 22.

8.1.1.4. The impactor, without foam covering and skin, shall be mounted with the tibia firmly clamped to a fixed horizontal surface and a metal tube connected firmly to the femur, as shown in Figure 23. To avoid friction errors, no support shall be provided to the femur section or the metal tube. The bending moment applied at the centre of the knee joint, due to the weight of the metal tube and other components (excluding the legform itself), shall not exceed 25 Nm.

A horizontal normal force shall be applied to the metal tube at a distance of 2.0 ± 0.01 m from the centre of the knee joint and the resulting angle of knee deflection shall be recorded. The load shall be increased until the angle of deflection of the knee is in excess of 22°.

The energy is calculated by integrating the force with respect to the bending angle in radians, and multiplying by the lever length of 2.0 ± 0.01 m.

8.1.1.5. The impactor, without foam covering and skin, shall be mounted with the tibia firmly clamped to a fixed horizontal surface and a metal tube connected firmly to the femur and restrained at 2.0 m from the centre of the knee joint, as shown in Figure 24.

A horizontal normal force shall be applied to the femur at a distance of 50 mm from the centre of the knee joint and the resulting knee shearing displacement shall be recorded. The load shall be increased until the shearing displacement of the knee is in excess of 8.0 mm or the load is in excess of 6.0 kN.

8.1.2. Dynamic tests

8.1.2.1. The lower legform impactor shall meet the requirements specified in paragraph 8.1.2.2. when tested as specified in paragraph 8.1.2.4.

8.1.2.2.]— The stabilised temperature of the impactor during certification shall be $20 \pm 2^\circ\text{C}$.

8.1.2.2.1. The relative humidity of a controlled storage area where all test impactors are stored shall be 40 per cent \pm 30 per cent after a stabilised period of at least four hours prior to impactor removal for calibration.

8.1.2.2.2. Each calibration shall be completed within two hours of when the impactor to be calibrated is removed from the controlled storage area.

8.1.2.2.3. Relative humidity and temperature of the calibration area shall be measured at the time of calibration, and recorded in the calibration report.]

8.1.2.23. When the impactor is impacted by a linearly guided certification impactor, as specified in paragraph 8.1.2.4., the maximum upper tibia acceleration shall be not less than 120 g and not more than 250 g. The maximum bending angle shall be not less than 6.2° and not more than 8.2°. The maximum shearing displacement shall be not less than 3.5 mm and not more than 6.0 mm.

For all these values, the readings used shall be from the initial impact with the certification impactor and not from the arresting phase. Any system used to arrest the impactor or certification impactor shall be so arranged that the arresting phase does not overlap in time with the initial impact. The arresting system shall not cause the transducer outputs to exceed the specified CAC.

8.1.2.34. The instrumentation response value CFC, as defined in ISO 6487:2002, shall be 180 for all transducers. The CAC response values, as defined in ISO 6487:2002, shall be 50° for the knee bending angle, 10 mm for the shearing displacement and 500 g for the acceleration. This does not require that the impactor itself be able to physically bend and shear to these angles and displacements.

8.1.2.45. Test procedure

8.1.2.45.1. The impactor, including foam covering and skin, shall be suspended horizontally by three wire ropes of 1.5 ± 0.2 mm diameter and of 2000 mm minimum length, as shown in Figure 25. It shall be suspended with its longitudinal axis horizontal, with a tolerance of $\pm 0.5^\circ$, and perpendicular to the direction of the certification impactor motion, with a tolerance of $\pm 2^\circ$. The impactor shall have the intended orientation about its longitudinal axis, for the correct operation of its knee joint, with a tolerance of $\pm 2^\circ$. The impactor must meet the requirements of paragraph 6.3.1.1., with the attachment bracket(s) for the wire ropes fitted.

8.1.2.45.2. The certification impactor shall have a mass of 9.0 ± 0.05 kg, this mass includes those propulsion and guidance components which are effectively part of the impactor during impact. The dimensions of the face of the certification impactor shall be as specified in Figure 26. The face of the certification impactor shall be made of aluminium, with an outer surface finish of better than 2.0 micrometers.

The guidance system shall be fitted with low friction guides, insensitive to off-axis loading, that allow the impactor to move only in the specified direction of impact, when in contact with the vehicle. The guides shall prevent motion in other directions including rotation about any axis.

8.1.2.45.3. The impactor shall be certified with previously unused foam.

8.1.2.45.4. The impactor foam shall not be excessively handled or deformed before, during or after fitting.

8.1.2.45.5. The certification impactor shall be propelled horizontally at a velocity of 7.5 ± 0.1 m/s into the stationary impactor as shown in Figure 26. The certification impactor shall be positioned so that its centreline aligns with a position on the tibia centreline of 50 mm from the centre of the knee, with tolerances of ± 3 mm laterally and ± 3 mm vertically.

8.2. Upper Legform Impactor

8.2.1. The upper legform impactor shall meet the requirements specified in paragraph 8.2.2 when tested as specified in paragraph 8.2.3.

[8.2.1.1.] The stabilised temperature of the impactor during certification shall be $20 \pm 2^\circ$ C.

[8.2.1.1.1.] The relative humidity of a controlled storage area where all test impactors are stored shall be 40 per cent \pm 30 per cent after a stabilised period of at least four hours prior to impactor removal for calibration.

8.2.1.1.2.] Each calibration shall be completed within two hours of when the impactor to be calibrated is removed from the controlled storage area.

8.2.1.1.3.] Relative humidity and temperature of the calibration area shall be measured at the time of calibration, and recorded in the calibration report.]

8.2.2. Requirements

8.2.2.1. When the impactor is propelled into a stationary cylindrical pendulum the peak force measured in each load transducer shall be not less 1.20 kN and not more than 1.55 kN and the difference between the peak forces measured in the top and bottom load transducers shall not be more than 0.10 kN. Also, the peak bending moment measured by the strain gauges shall not be less than 190 Nm and not more than 250 Nm on the centre position and not less than 160 Nm and not more than 220 Nm for the outer positions. The difference between the upper and lower peak bending moments shall not be more than 20 Nm.

For all these values the readings used shall be from the initial impact with the pendulum and not from the arresting phase. Any system used to arrest the impactor or pendulum shall be so arranged that the arresting phase does not overlap in time with the initial impact. The arresting system shall not cause the transducer outputs to exceed the specified CAC.

8.2.2.2. The instrumentation response value CFC, as defined in ISO 6487:2002, shall be 180 for all transducers. The CAC response values, as defined in ISO 6487:2002, shall be 10 kN for the force transducers and 1000 Nm for the bending moment measurements.

8.2.3. Test procedure

8.2.3.1. The impactor shall be mounted to the propulsion and guidance system, by a torque limiting joint. The torque limiting joint shall be set so that the longitudinal axis of the front member is perpendicular to the axis of the guidance system, with a tolerance of $\pm 2^\circ$,

with the joint friction torque set to 675 ± 25 Nm. The guidance system shall be fitted with low friction guides that allow the impactor to move only in the specified direction of impact, when in contact with the pendulum.

- 8.2.3.2. The impactor mass shall be adjusted to give a mass of 12 ± 0.1 kg, this mass includes those propulsion and guidance components which are effectively part of the impactor during impact.
- 8.2.3.3. The centre of gravity of those parts of the impactor which are effectively forward of the torque limiting joint, including the extra weights fitted, shall lie on the longitudinal centreline of the impactor, with a tolerance of ± 10 mm.
- 8.2.3.4. The impactor shall be certified with previously unused foam.
- 8.2.3.5. The impactor foam shall not be excessively handled or deformed before, during or after fitting.
- 8.2.3.6. The impactor with the front member vertical shall be propelled horizontally at a velocity of 7.1 ± 0.1 m/s into the stationary pendulum as shown in Figure 27.
- 8.2.3.7. The pendulum tube shall have a mass of 3 ± 0.03 kg, a wall thickness of 3 ± 0.15 mm and an outside diameter of $150 \text{ mm} +1 \text{ mm}/-4 \text{ mm}$. Total pendulum tube length shall be 275 ± 25 mm. The pendulum tube shall be made from cold finished seamless steel (metal surface plating is permissible for protection from corrosion), with an outer surface finish of better than 2.0 micrometers. It shall be suspended on two wire ropes of 1.5 ± 0.2 mm diameter and of 2.0 m minimum length. The surface of the pendulum shall be clean and dry. The pendulum tube shall be positioned so that the longitudinal axis of the cylinder is perpendicular to the front member (i.e. level), with a tolerance of $\pm 2^\circ$, and to the direction of impactor motion, with a tolerance of $\pm 2^\circ$, and with the centre of the pendulum tube aligned with the centre of the impactor front member, with tolerances of ± 5 mm laterally and ± 5 mm vertically.

8.3. Certification procedure for child and adult headform impactors

8.3.1. Drop test

8.3.1.1. Performance Criteria

The headform impactors shall meet the requirements specified in paragraph 8.3.2. when tested as specified in paragraph 8.3.3.

8.3.2. Requirements

8.3.2.1. When the headform impactors are dropped from a height of 376 ± 1 mm in accordance with paragraph 8.3.3. the peak resultant acceleration measured by one triaxial (or three uniaxial) accelerometer (accelerometers) in the headform impactor shall be:

- for the child headform impactor not less than 245 g and not more than 300 g;

- for the adult headform impactor not less than 225 g and not more than 275 g.

The acceleration time curve shall be uni-modal.

8.3.2.2. The instrumentation response values CFC and CAC for each accelerometer shall be 1000 Hz and 500 g respectively as defined in ISO 6487:2002.

8.3.2.3. Temperature conditions

The headform impactors shall have a temperature of $20 \pm 2^{\circ}\text{C}$ at the time of impact. The temperature tolerances shall apply at a relative humidity of 10 to 70 per cent after a soak period of at least four hours prior to their application in a test.

8.3.2.4. After complying with the certification test, each headform impactor can be used for a maximum of 20 impact tests.

8.3.3. Test Procedure

8.3.3.1. The headform impactor shall be suspended from a drop rig as shown in Figure 28.

8.3.3.2. The headform impactor shall be dropped from the specified height by means that ensure instant release onto a rigidly supported flat horizontal steel plate, over 50 mm thick and over 300 mm square which has a clean dry surface and a surface finish of between 0.2 and 2.0 micrometers.

8.3.3.3. The headform impactor shall be dropped with the rear face of the impactor at the test angle specified in paragraph 7.3.6. for the child headform impactor and in paragraph 7.4.6. for the adult headform impactor with respect to the vertical as shown in Figure 28. The suspension of the headform impactor shall be such that it does not rotate during the fall.

8.3.3.4. The drop test shall be performed three times, with the headform impactor rotated 120° around its symmetrical axis after each test.

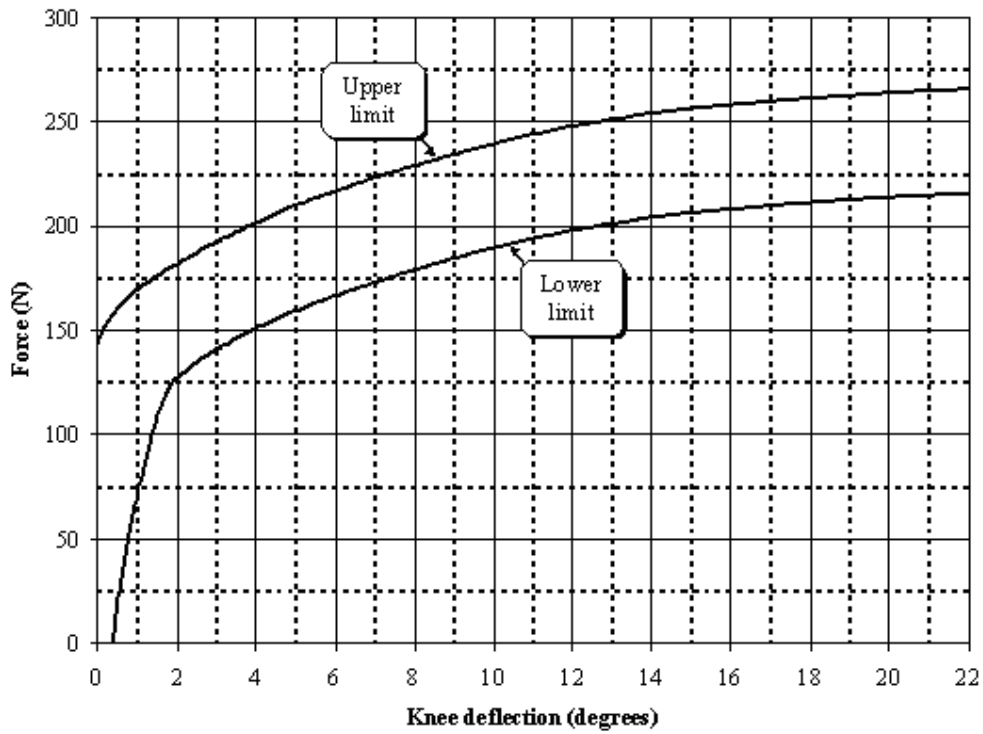

Figure 21. Force versus angle requirement in static lower legform impactor bending certification test (see paragraph 8.1.1.2.)

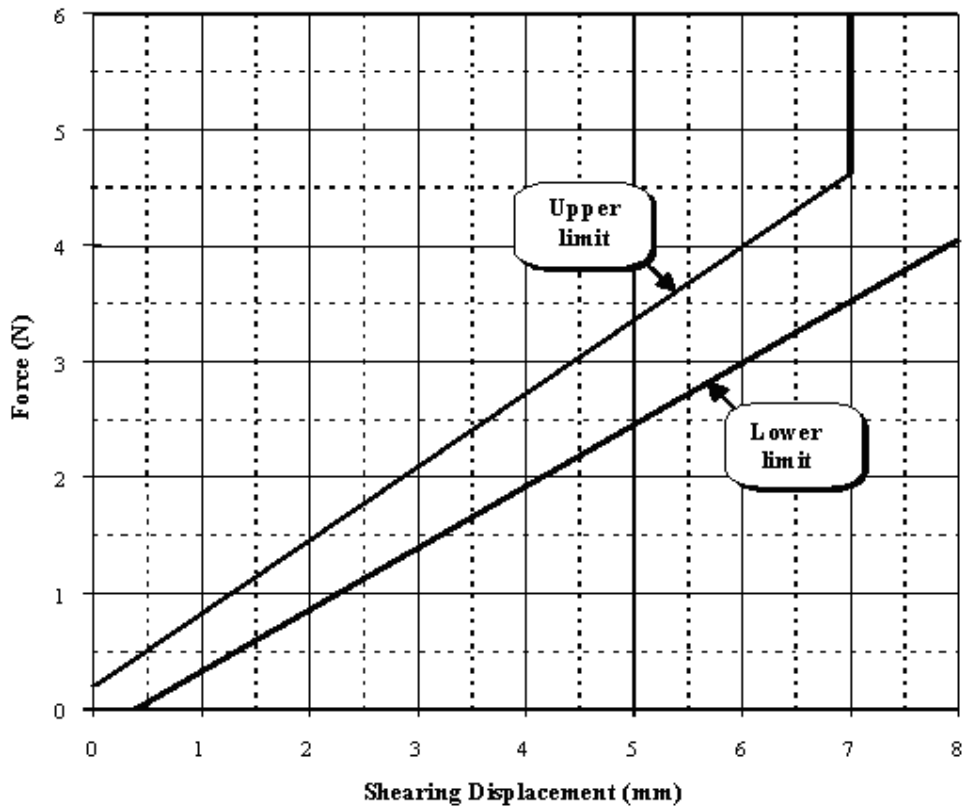

Figure 22. Force versus displacement requirement in static lower legform impactor shearing

certification test (see paragraph 8.1.1.3.)

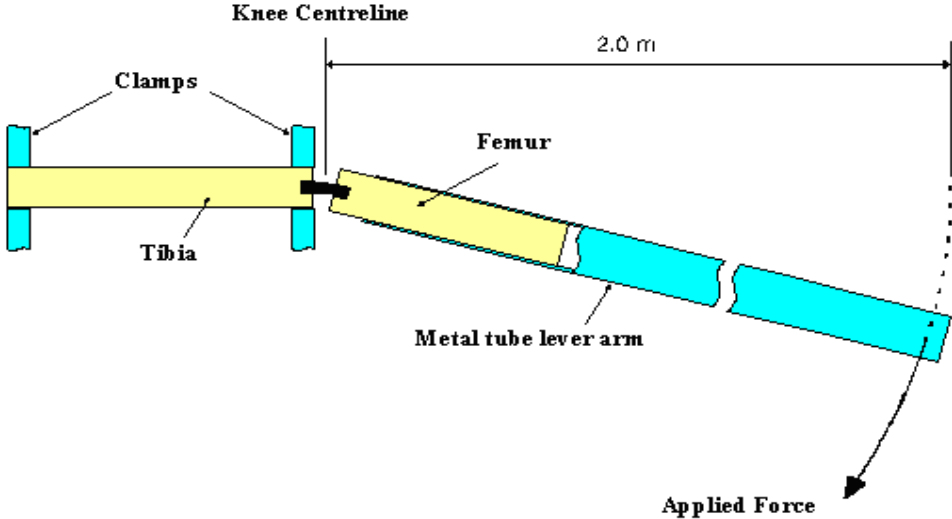

Figure 23. Top View of Test set-up for static lower legform impactor bending certification test (see paragraph 8.1.1.4.)

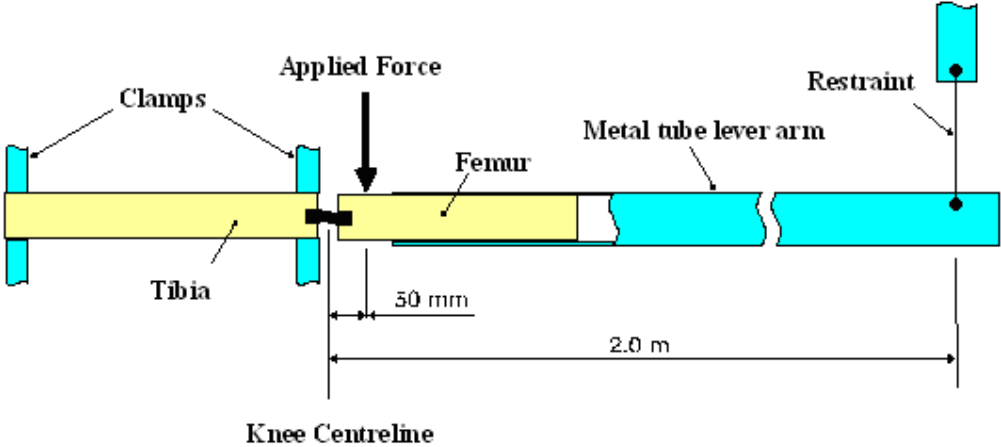

Figure 24. Top View of Test set-up for static lower legform impactor shearing certification test (see paragraph 8.1.1.5.)

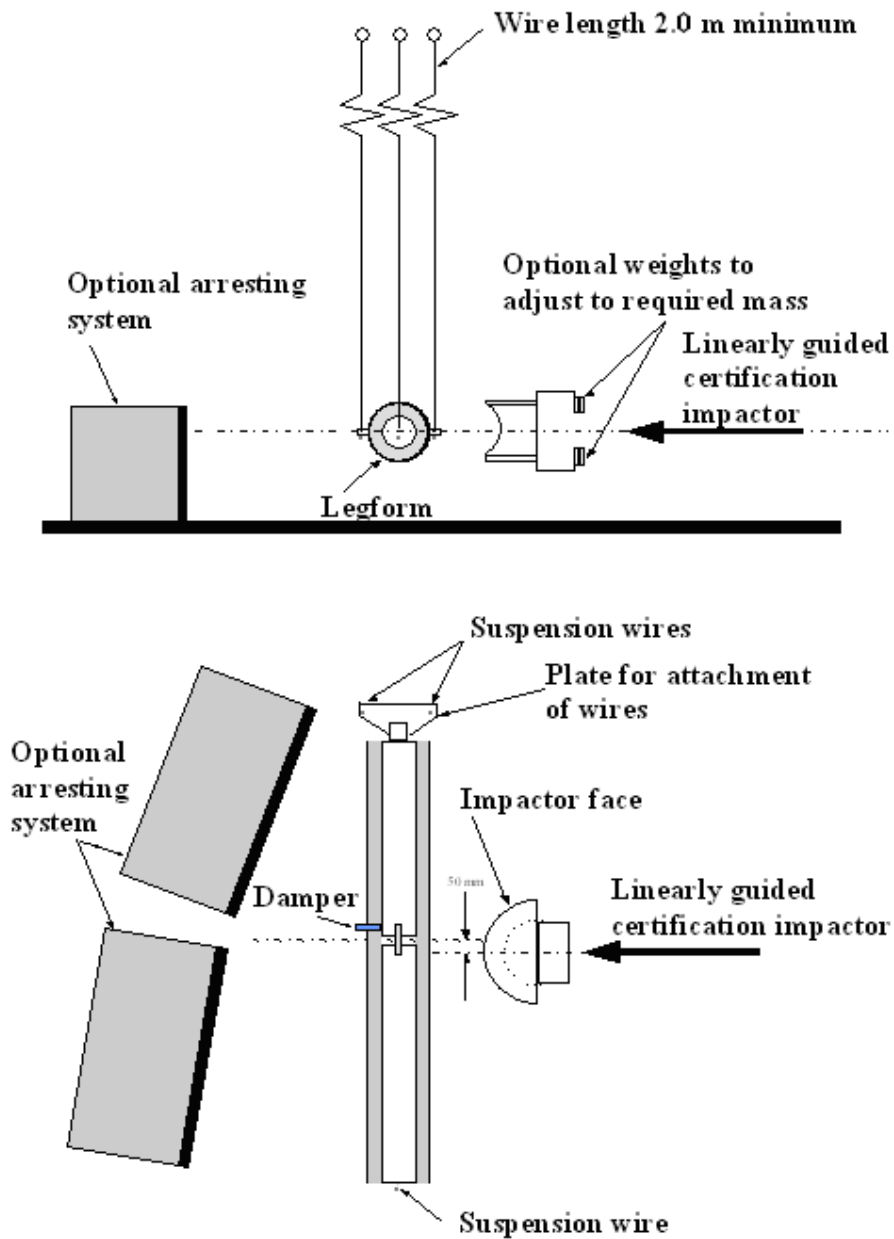

Figure 25. Test set-up for dynamic lower legform impactor certification test (side view top diagram, view from above bottom diagram) (see paragraph 8.1.2.4.1.)

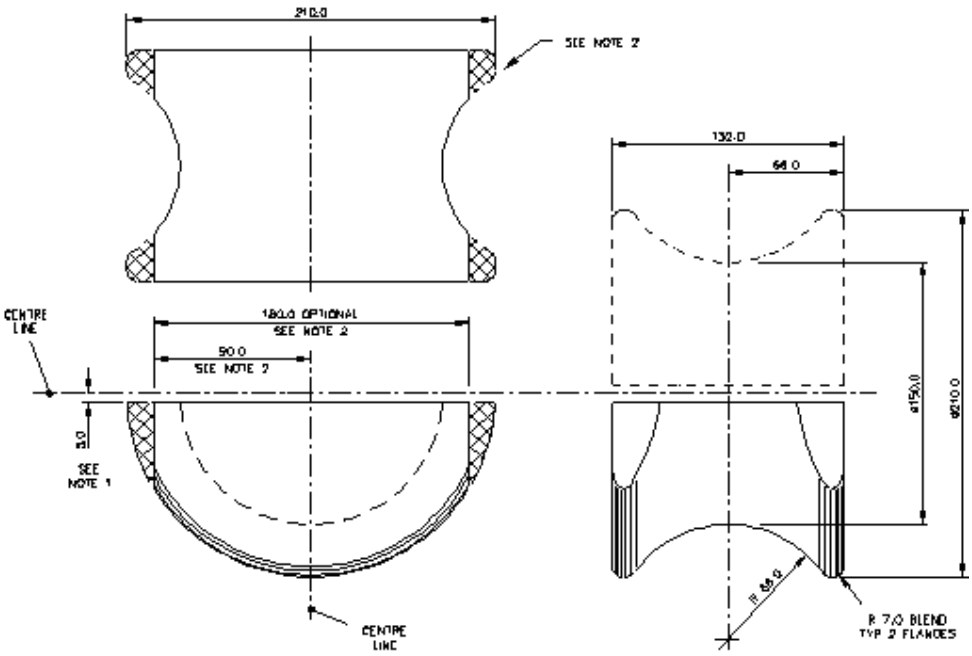

Figure 26. Details of dynamic lower legform certification impactor face (see paragraph 8.1.2.4.2.)

Notes:

1. Saddle may be made as a complete diameter and cut as shown to make two components.
 2. The shaded areas may be removed to give the alternative form shown.
 3. Tolerance on all dimensions is ± 1.0 mm.
- Material: Aluminium alloy

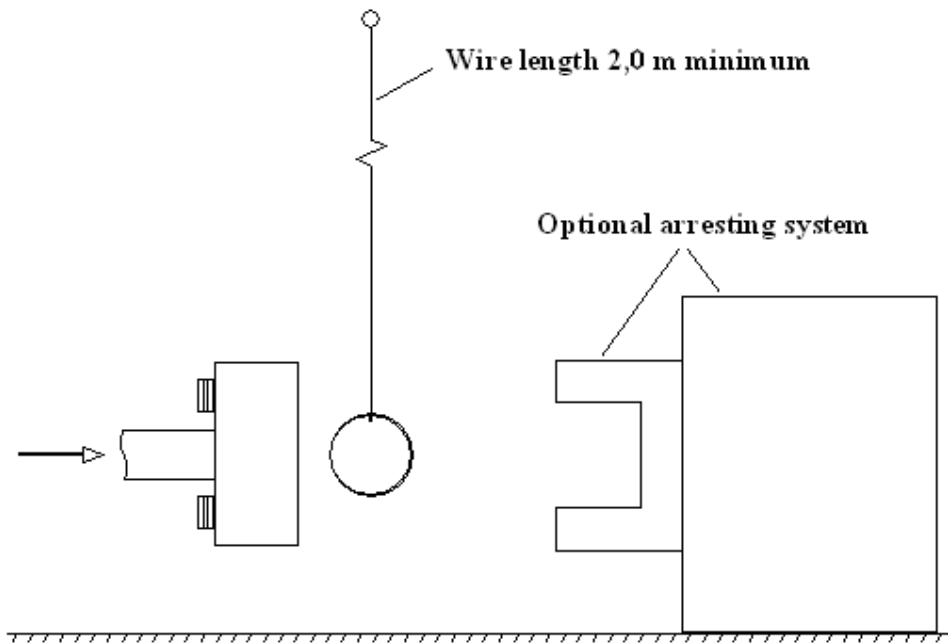

Figure 27. Test set-up for dynamic upper legform impactor certification test (see paragraph 8.2.3.6)

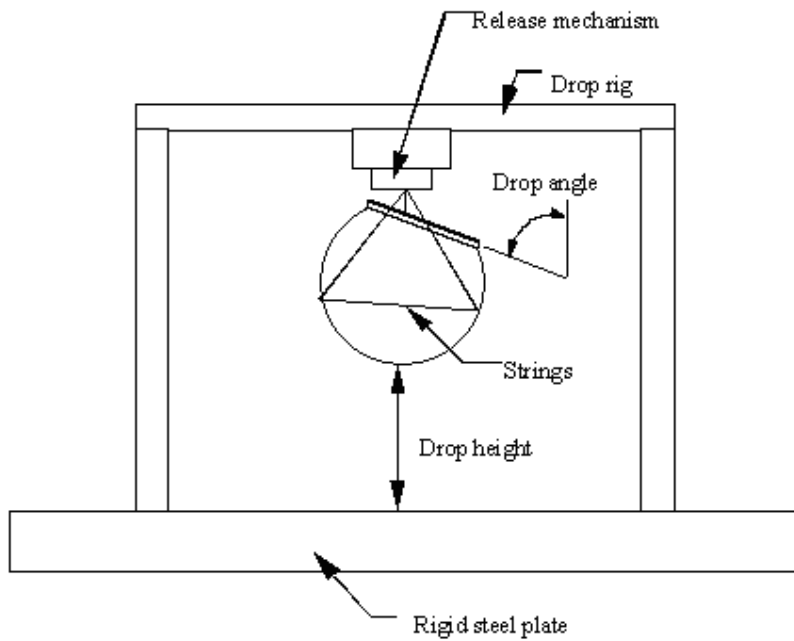

Figure 28. Test set-up for dynamic headform impactor biofidelity test (see paragraph 8.3.3.1.)

ANNEX 1: Example of guidelines for testing active devices designed to protect vulnerable road users when impacted by the vehicle.

ANNEX 2: Impactor handling procedures including:

- soaking conditions
- time between soaking and testing
- time in between tests