

ECONOMIC COMMISSION FOR EUROPE

INLAND TRANSPORT COMMITTEE

Working Party on the Transport of Dangerous Goods

Eighty-fourth session

Geneva, 5-9 May 2008

Item 5(a) of the provisional agenda

## PROPOSALS FOR AMENDMENTS TO ANNEXES A AND B OF ADR

Proposal for amendment to text in document 2008/4 "Provisions for Mobile Explosives Manufacturing Units (MEMUs)" from the working group on MEMUs

Transmitted by the Government of Norway

<b>SUMMARY</b>	
<b>Executive summary:</b>	<p>Proposal for amendment in the text from the working group on MEMUs: The original text proposal in section. 6.12.3.2.4 make it difficult to produce small tanks</p> <p>When the text was originally written, the meaning was that the maximum distance between two parallel supports (ribs or bends in a corrugated wall) should be maximum 100 times the wall thickness. This should however only apply in one direction since this gives enough support. There should not be any constraints to the distance in the other direction (the longest direction - parallel to the supports). This could make the tank difficult to make without giving any benefits.</p>
<b>Action to be taken:</b>	<p>Adopting the new text proposal for section 6.12.3.2.4.</p> <p><i>"Tanks may have constructional parts that are without a radius of convexity. Alternative supportive measures may be corrugated walls or ribs. In at least one direction the distance between parallel supports shall not be greater than 100 times the wall thickness."</i></p>
<b>Related documents:</b>	<p><u>Provisions for Mobile Explosives Manufacturing Units (MEMUs) section 6.12.3.2.4.</u></p>

**Background**

The Norwegian representative to the MEMU working group, Mr Johan Røneid, and Oricas design experts have looked at the new text and discovered a need for correction of one of the latest changes the working group made on the last day of the last meeting in the working group. The text in this section could easily be misunderstood and the change they made changed the content in a way we believe was not intended.

The correction is needed in section 6.12.3.2.4. The way the text is now, it will be more difficult to make the small tanks in a reasonable manner.

**Justification:**

The word "SHORTEST" was during the last hour of the last meeting replaced by "LONGEST" as shown below.

Current text:

6.12.3.2.4 Tanks may have constructional parts that are without a radius of convexity. The **longest** (~~shortest~~) non-supported measurement of such parts shall not be greater than 100 times the wall thickness. Such supportive measures may be curved walls, corrugated walls or ribs.

The illustration below is explaining the difference:

Example:

A tank with volume 750 litres is made of 5 mm plane plates.

100 x plate thickness = 500 mm.

A stiffening rib, located at the shortest non-supported measurement, 370 mm (< 500 mm) from each side gives sufficient support.

However, the longest non-supported measurement is 1000 mm!

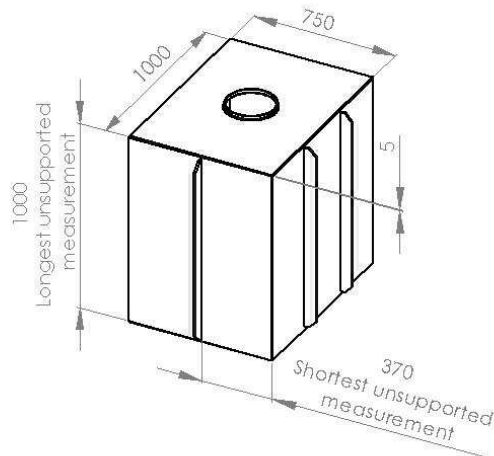

When the text was originally written, the meaning was that the maximum distance between two parallel supports (ribs or bends in a corrugated wall) should be maximum 100 times the wall thickness. This should however only apply in one direction since this gives enough support.

There should not be any constraints to the distance in the other direction (the longest direction - parallel to the supports). This could make the tank difficult to make without giving any benefits.

## Proposal

Suggestion for new text:

Below we have also rewritten the text a little to make it easier to understand. (Sentence three becomes sentence two and the original sentence two is rewritten.)

### *New text for better understanding:*

6.12.3.2.4 Tanks may have constructional parts that are without a radius of convexity. **Alternative supportive measures may be corrugated walls or ribs. In at least one direction the distance between parallel supports shall not be greater than 100 times the wall thickness.**

(Text in red is new)

### *Alternative 2:*

If the amendment above cannot be accepted, we suggest that a few additional words are added as shown below:

6.12.3.2.4 Tanks may have constructional parts that are without a radius of convexity. The longest non-supported measurement *in at least one direction* of such parts shall not be greater than 100 times the wall thickness. Such supportive measures may be curved walls, corrugated walls or ribs.

(Text in blue is new)

### Example:

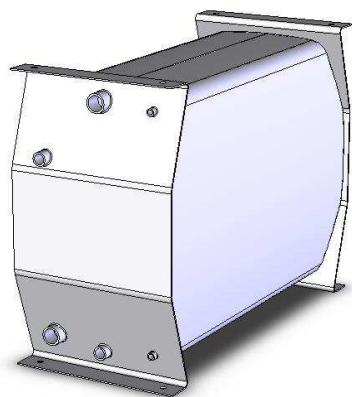

This figure shows how a small tank with curved walls and corrugated ends typically could look.

The change of wording is most important for the corrugated ends on this figure. It is only possible to bend a plate in one direction at the time.

---