



YOUR DEVELOPMENT PARTNER

Informal document No. GRSP-44-29
(44th GRSP, 10-13 December 2008,
agenda item 19(b))

STATUS OF CRS IN BUSES AND COACHES

44TH GRSP (9-12 DECEMBER)

SCOPE OF THE STUDY:

- Analysis of standards required to approve a vehicle M2-M3 and the relationship with the CRS.
- Analysis of the current retention systems installed in vehicles M2-M3 to restraint minors of 12 years old.
- Basis of new Regulation of CRS for M2-M3 categories

With the study of the accidents occurred during last years in the Spanish roads we have arrived to the next conclusions:

- Number of accidents with victims caused by buses is low(1% of accidents with victims), but the number of victims for number of vehicles is high (5 dead every 10.000 buses in front of 2 dead every 10.000 passenger cars).
- More usual accidents are frontal crash and rollover
- Standards related with passenger protection in buses and coaches are focused to protect the adult passenger.
- The standards relative to the child protection (Reg 44.04/ECE) is totally developed for vehicles M1, and the fulfilling of this standards in vehicles M2-M3 is incoherent with the current standards demanded to approve these vehicles.

For Buses and coaches in Europe to fulfill with the following European Directives related with the seats, their anchorages, the safety belts and the safety belts anchorages is mandatory :

- Directive 2005/39/EC (R80.02 ECE): seats and their anchorages
- Directive 2005/40/EC (R16.05 ECE): safety belt installation
- Directive 2005/41/EC(R14.06 ECE): seat belt anchorages
- Directive 2001/85/EC: General safety
- Directive 2003/20/EC Safety belt use

Directive 2005/39/EC (R80.02 ECE):

Main requirements:

- Dynamic tests with 2 dummies HIBRYD III unbelted and belted.
- Acceleration corridor; 8-12 g
- Velocity: 30-32 km/h

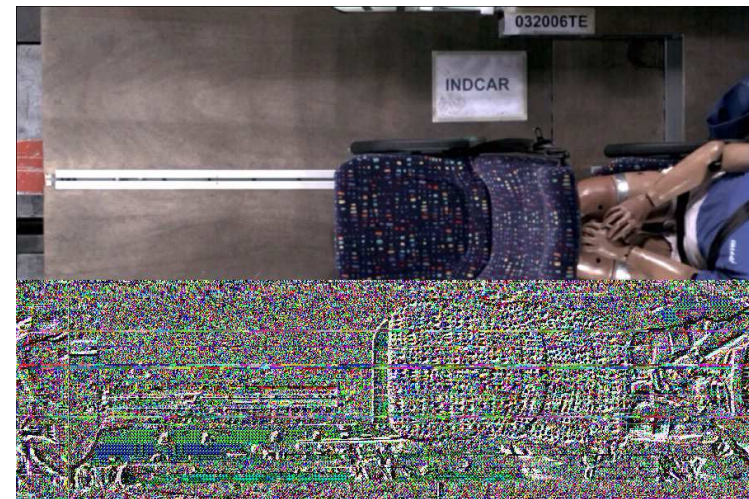
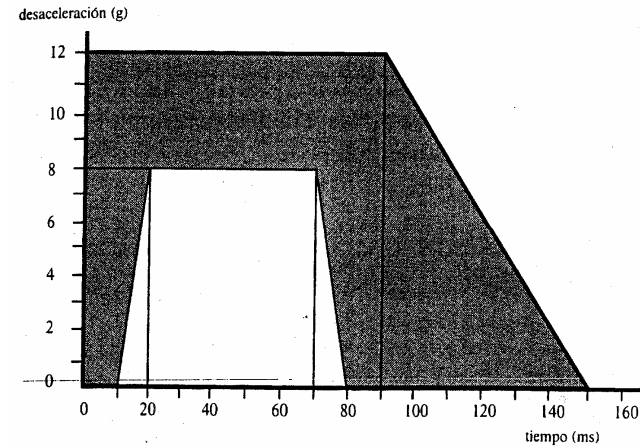

DIRECTIVE 2005/40: Installation of safety belts:

- To vehicles M2-M3 categories:
 - The installation of 2 points safety belts is mandatory
 - 3 points safety belts only is required ins exposed seats

REMARKS: Around 90 % of the buses and coaches manufactured these year install 2 points safety belts.

DIRECTIVE 2005/41: Strength of the seat belt anchorages

- Main tests:
 - Traction tests of the seat belt anchorages with specific loads for vehicles M2 and vehicles M3
 - Location of the effective anchorages

Directive 2001/85/EC:

This directive defines the space between 2 seats, the cushion height and width.

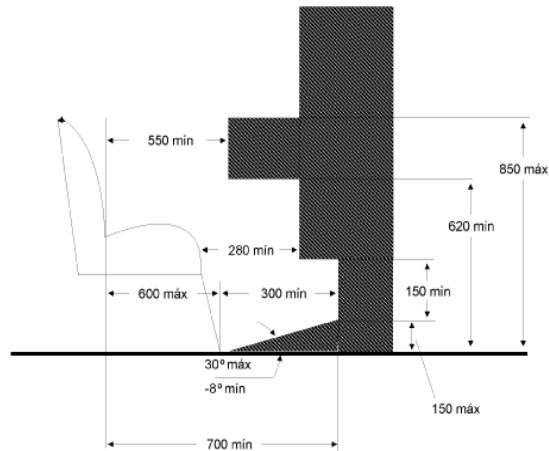

Directive 2003/20:

Directive covers the installation of CRS in vehicles M1, and vehicle M2-M3 for children with more of 3 years old.

Regulation 44.04:

The Reg 44.04 allows the approval of CRS for all the vehicle categories.

However, the deceleration corridor used is the same for all categories of vehicles, and is related with M1 category

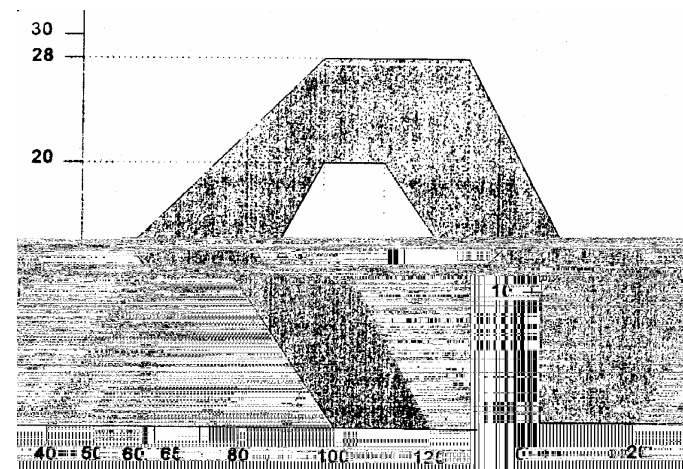

*Analyzing all these requirements
we arrive to the next
conclusions:*

- Unrealistic deceleration to approve CRS in buses and coaches
- CRS too much reinforced
- Specific approvals for every vehicle, when the vehicle fulfill with all the seats and seat belt anchorages approvals.
- Seats distance /deceleration R44.04

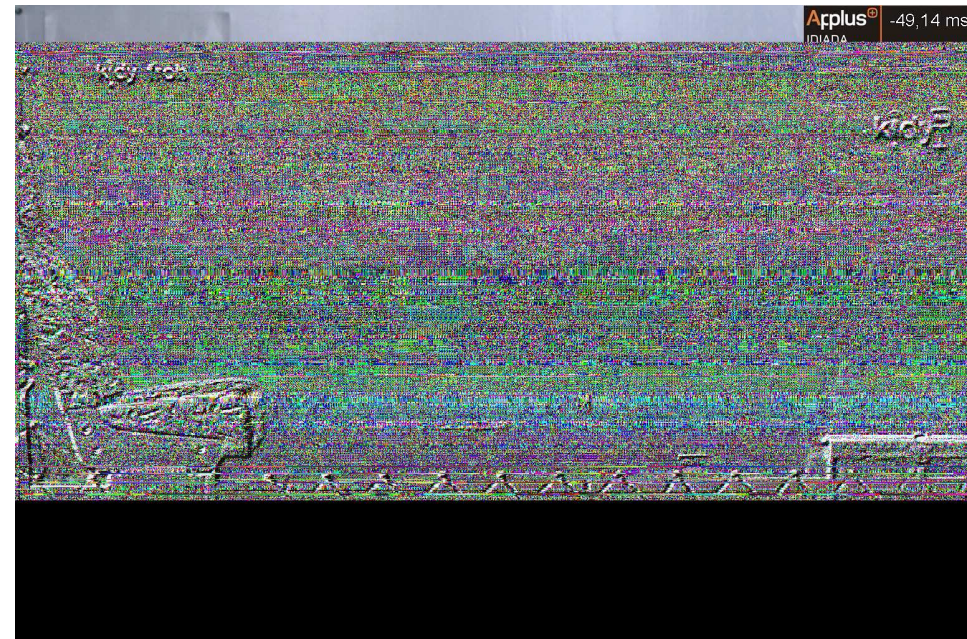

- The different retention systems applied to the buses and coaches have been analyzed to define the level of safety of these systems:
 - Compartmentation
 - 2 points safety belts
 - 3 points safety belts

We have studied by simulation the effects of the retention with these systems and we have applied to a real accidents

- **Child Injuries without safety belt, 2 points safety belts and 3 points safety belts**
- **Frontal impact without safety belt:**
 - High severity injuries in head, neck and chest.
 - Injuries in legs and arms
- **Rollover without safety belt:**
 - High severity injuries in head, neck and chest.
 - Injuries in legs and arms

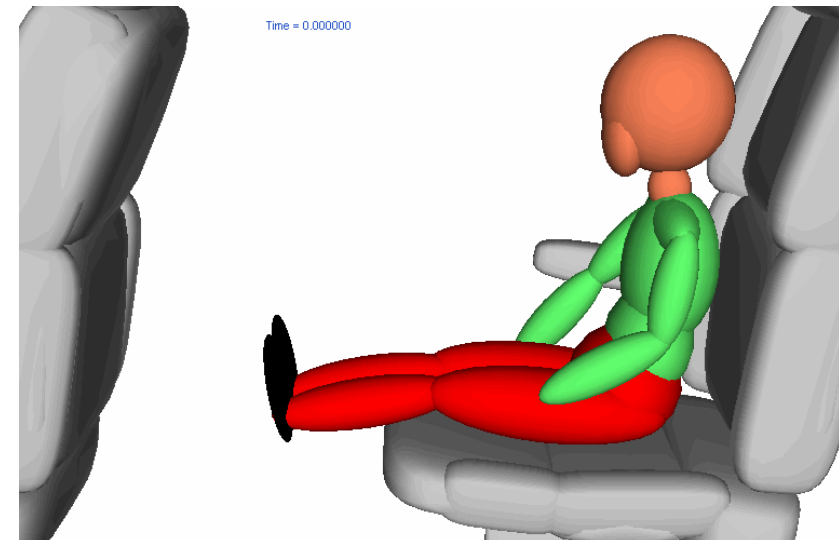
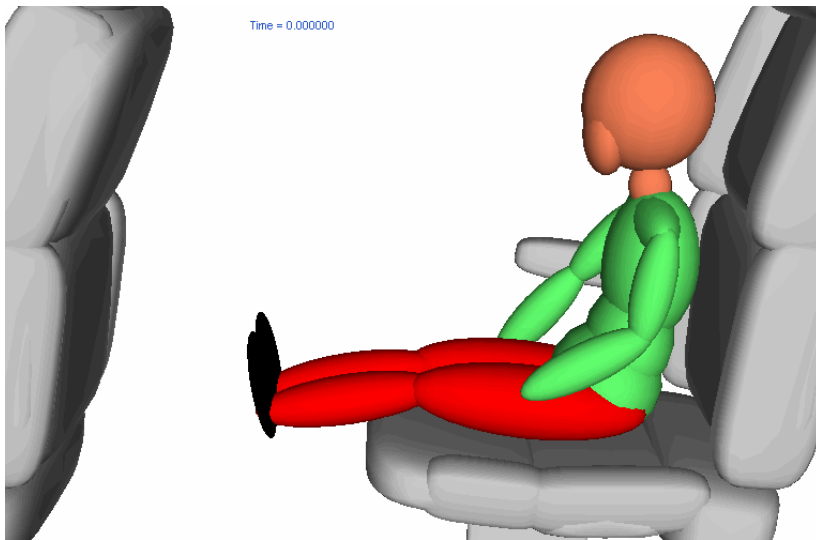

(RACC-JANÉ) SCHOOL TRANSPORT STUDY

STATUS OF CRS IN BUSES AND COACHES



- **Frontal impact**
 - Velocity impact: 70 km/h
 - Average Deceleration: 13,7 g

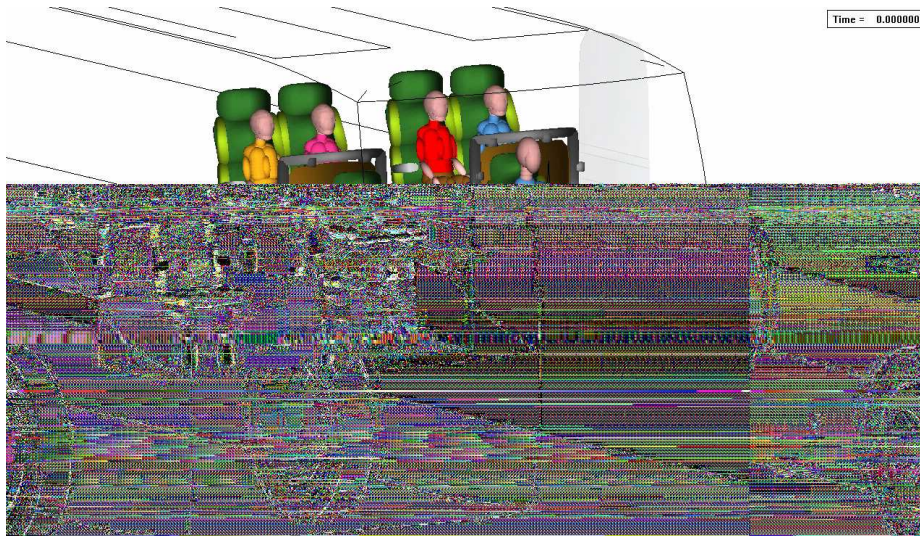

- Frontal impact with 2 points seat belt
 - Child retention
 - Injuries in head and chest
 - High probability of Abdomen injuries

- Rollover with 2 points seat belts:
 - No risk of ejection
 - Legs and arms move without control.

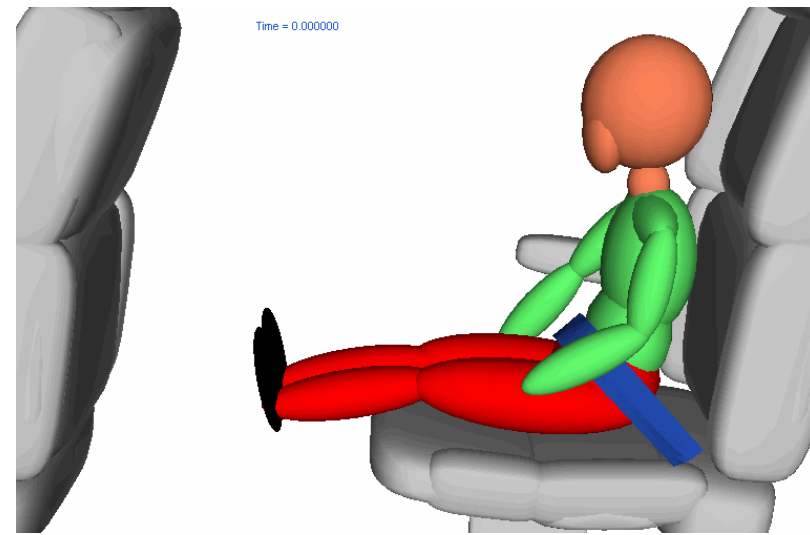
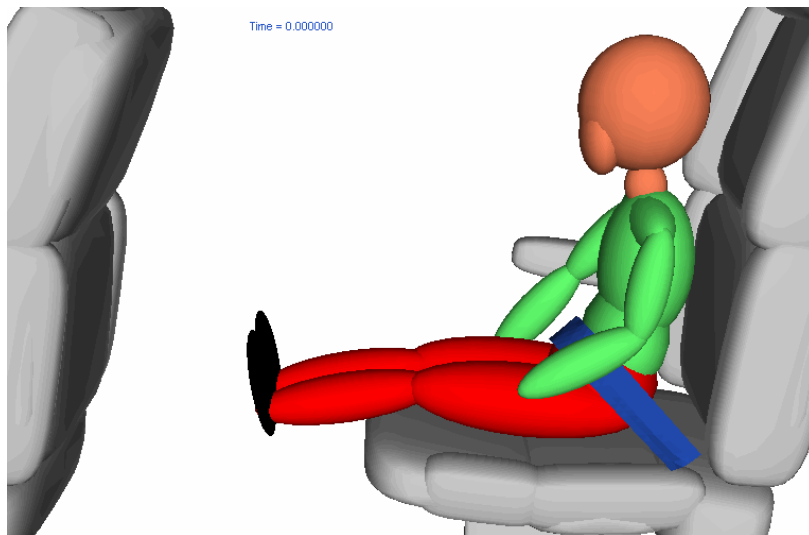

(RACC-JANÉ) SCHOOL TRANSPORT STUDY

- **Frontal impact with a lorry**
 - Velocity impact: 70 km/h
 - Average Deceleration: 13,7 g

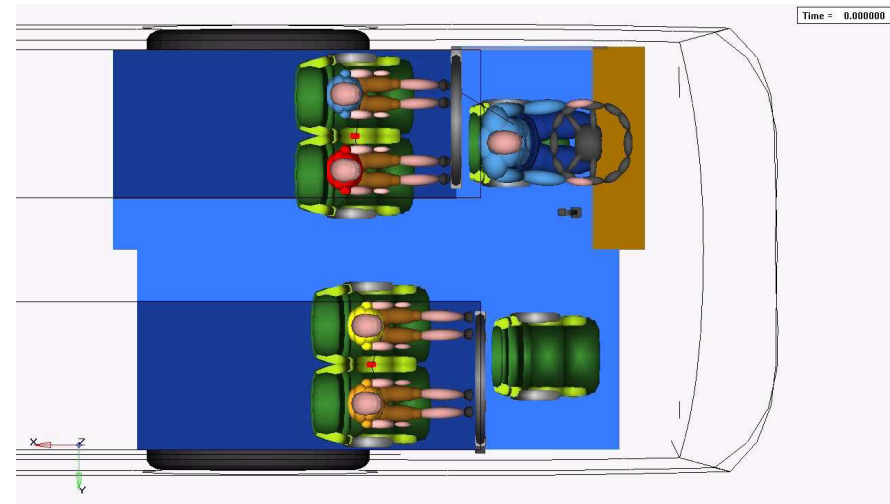

- **Frontal impact with 3 points safety belts:**

- Good level of retention limiting chest deformation
- Probability of injuries in neck.

- **Rollover with 3 points safety belts:**

- Good level of retention.
- Level of protection is different depending on the weight and height of the children

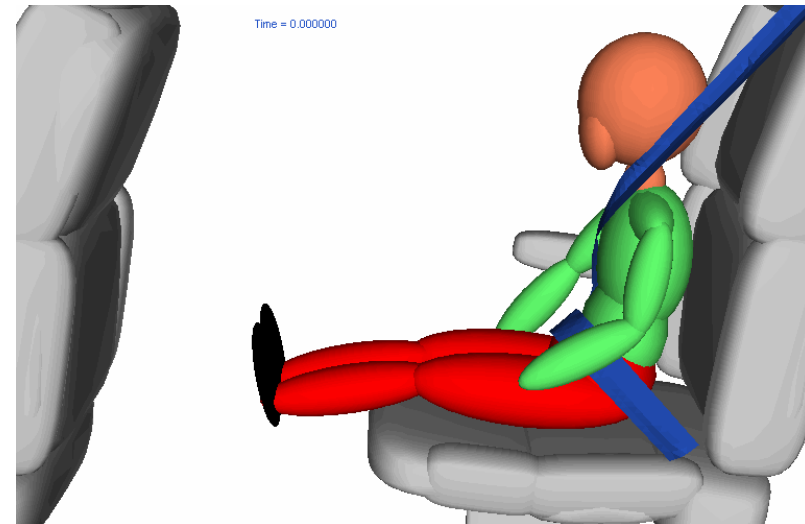
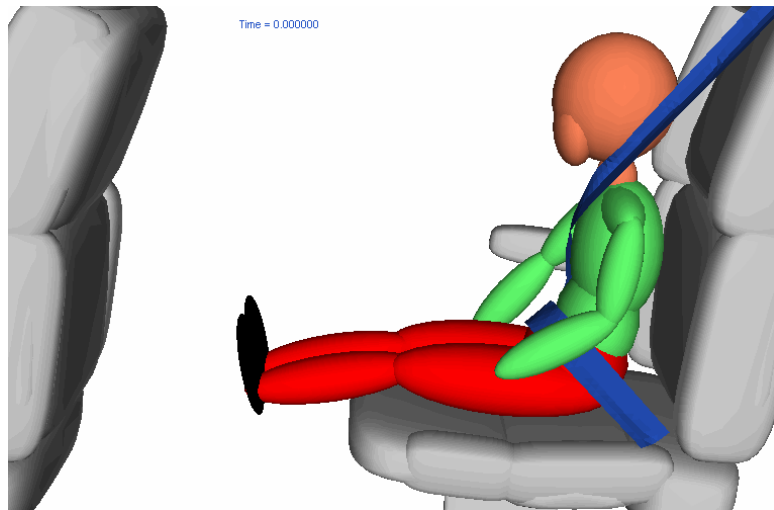

(RACC-JANÉ) SCHOOL TRANSPORT STUDY

- **Frontal impact with a lorry**
 - Velocity impact: 70 km/h
 - Average Deceleration: 13,7 g

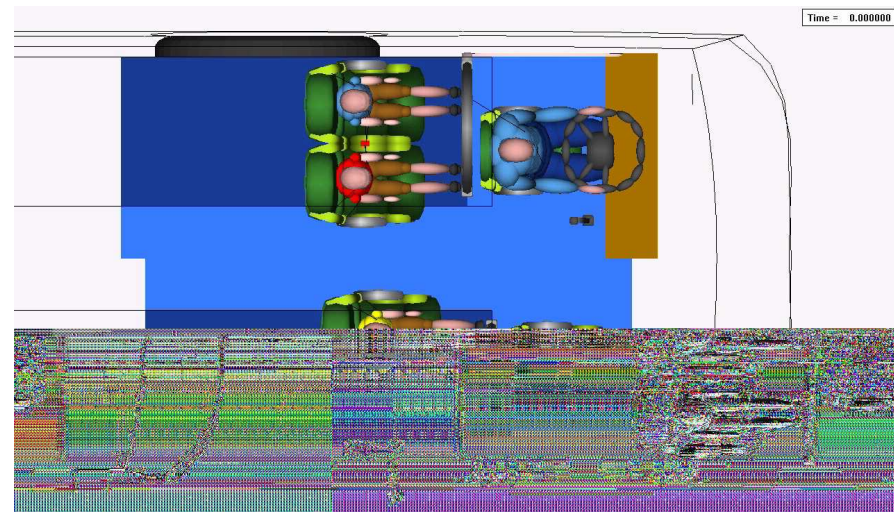
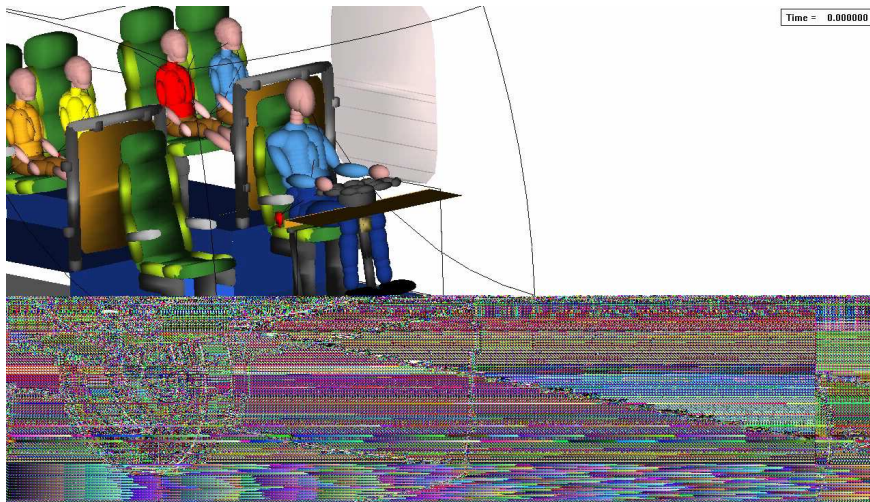

The main conclusions of this study are:

- Compartmentation doesn't protect the child in any case (frontal and rollover)
- Safety belts of 2 points and 3 points designed to protect the adults are not adequate to protect the children of less of 12 years.
 - 2 points safety belt offers a good level of retention, but there is a high probability of injuries in head, neck and the abdomen area.
 - 3 points safety belt offer a very good level of retention but it appears injuries in the neck of the child occurs.

Interaction of Directives applied to the buses and coaches and CRS:

- Tests to homologate a M2-M3 seats are performed to a deceleration of 8-12 g with a speed of 30-32 km/h, tests to approve a CRS in buses are performed with a deceleration of 20-24g and velocity of 48-50 km/h
- Seat dimensions and passenger space are different in M2-M3 vehicles and M1 vehicles, the CRS designed for M1 vehicles, and approved according to the provisions of Reg.44.04 can not be adapted to M2-m3 vehicles.
- Buses install 2 points safety belts and the CRS approved according to Reg.44 only works with 3 points safety belts.

Design of a CRS adecuated to vehicles M2-M3:

- Dimensions of the seats:

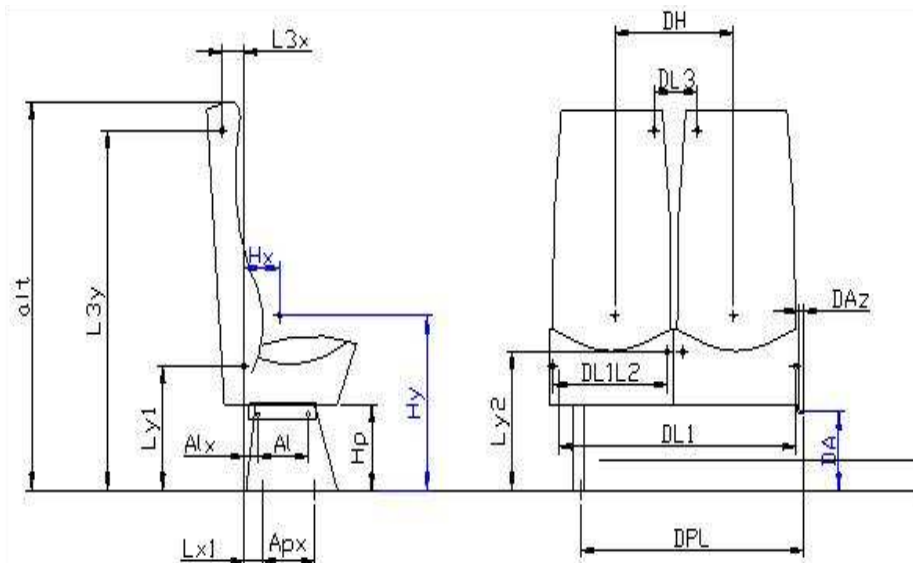

- Frontal distance allowed:

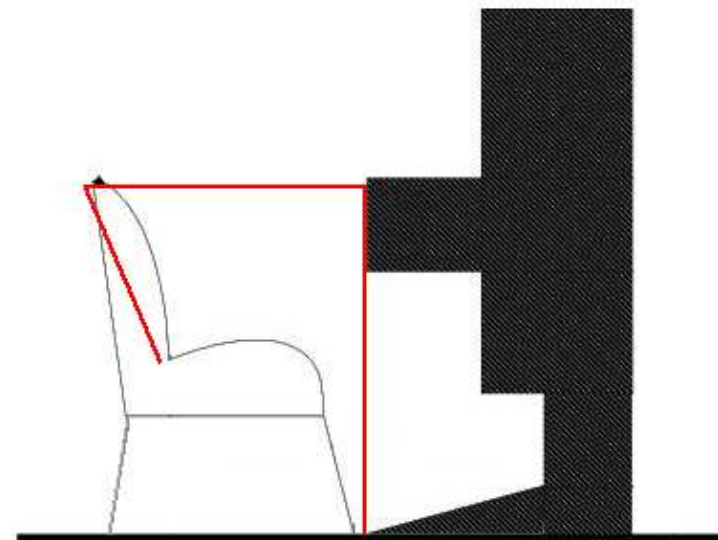

- Location of effective anchorages and real anchorages.

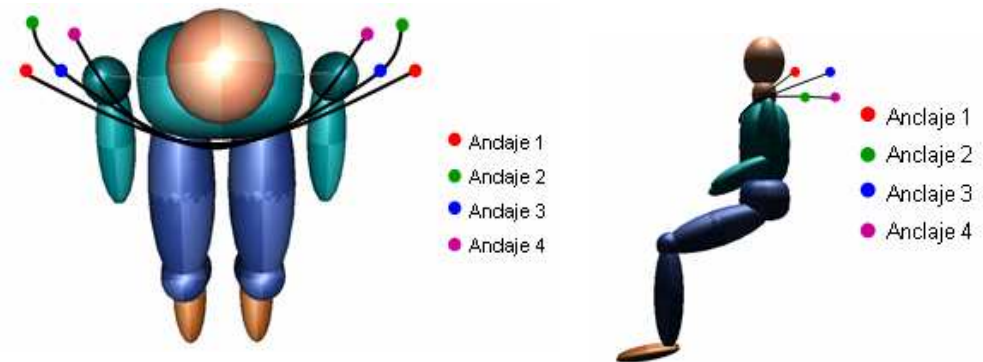

- In the drawings anchorage 4 (purple) is in the best location to protect the child

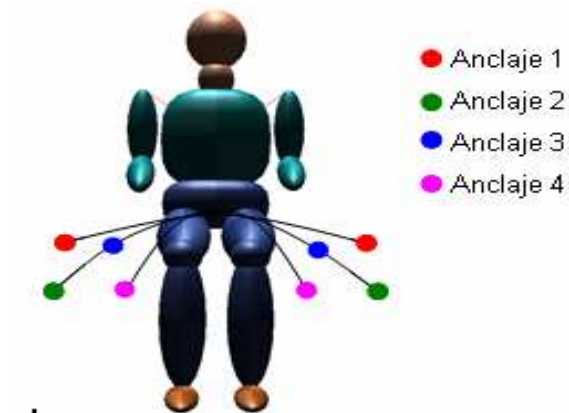

- Bases for a new Regulation of CRS in buses and coaches
 - Seat integrated systems/external systems like UNIVERSAL
 - Frontal impact tests and rollover tests
 - Dynamic test in line with the M2-m3 vehicles
 - Dimensional checking in line with the interior spaces of vehicles M2-M3
 - To allow CRS with de 2 points and 3 points seat belt



STATUS OF CRS IN BUSES AND COACHES

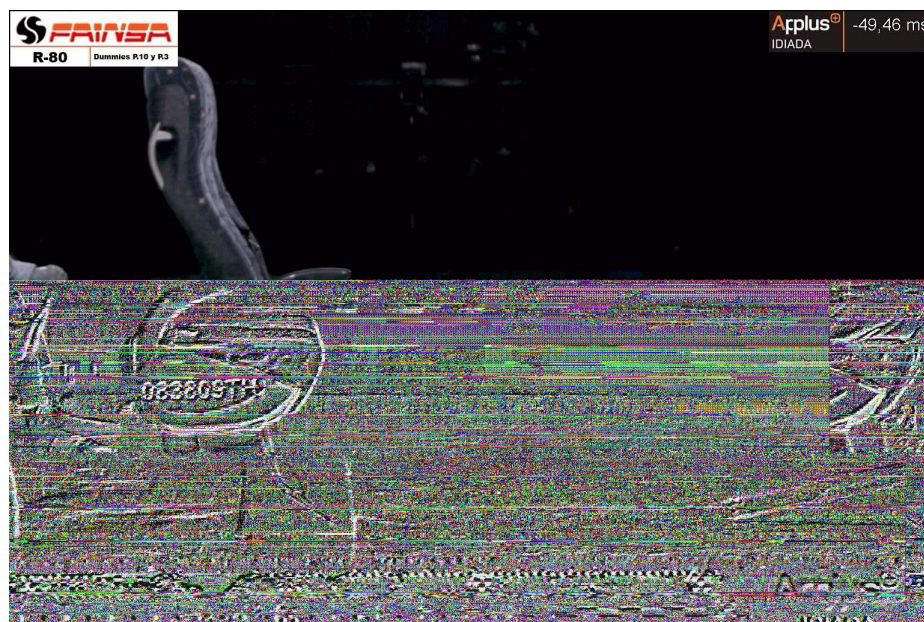

Thank you for your attention



For further information:
Sergi Ferris
Homologation engineer
Applus+ IDIADA
Main Technical Centre
L'Albornar – PO Box 20
E-43710 Santa Oliva (Tarragona) Spain
T +34 977 166 000
F +34 977 166 007
e-mail: idiada@idiada.com

www.idiada.com



IDIADA Fahrzeugtechnik GmbH
T +49 (0) 841 8 85 38 0 (Ingolstadt)
T +49 (0) 893 0 90 56 0 (München)
e-mail: idiada_germany@idiada.com

Applus Automotive Technology Luxembourg
T +352 779 113
e-mail: idiada_luxembourg@idiada.com

CTAG IDIADA Safety Technology SL
T +34 986 900 300
e-mail: ctag_idiada@idiada.com

IDIADA CZ a. s.
T +420 493 654 811
e-mail: info@idiada.cz

IDIADA Automotive Technology Services (Shanghai) Co., Ltd.
T +86 (21) 6210 0894
e-mail: idiada_china@idiada.com

IDIADA Automotive Technology India Pvt. Ltd.
T +91 12 44201156
e-mail: idiada_india@idiada.com

Applus+ IDIADA France
T +33 (0) 1 41 14 60 85
e-mail: idiada_france@idiada.com

Applus+ IDIADA Italy
T +39 011 3997 764
e-mail: idiada_italia@idiada.com

Applus+ IDIADA Madrid
T +34 915 095 795
e-mail: idiada_madrid@idiada.com

Applus+ IDIADA Poland
T +48 61 6226 905
e-mail: idiada_poland@idiada.com

Applus+ IDIADA UK
T +44 (0) 7 979 691 631
e-mail: idiada_uk@idiada.com

Applus+ IDIADA Japan
T +81 (0) 3 5979 2286
e-mail: idiada_japan@idiada.com

Applus+ IDIADA Korea
T +82 31 478 1821
e-mail: idiada_korea@idiada.com

Applus+ IDIADA Malaysia
T +603 2140 2266
e-mail: idiada_malaysia@idiada.com

Applus+ IDIADA Taiwan
T +886 4 7810702
e-mail: idiada_taiwan@idiada.com

Applus+ IDIADA Brasil
T +55 11 75489956
e-mail: gkobayashi@idiada.com