



**Economic and Social
Council**

Distr.
GENERAL

ECE/TRANS/WP.29/2009/91
27 July 2009

ENGLISH
Original: ENGLISH AND FRENCH

ECONOMIC COMMISSION FOR EUROPE

INLAND TRANSPORT COMMITTEE

World Forum for Harmonization of Vehicle Regulations

One-hundred-and-forty-ninth session
Geneva, 10-13 November 2009
Item 4.2.15 of the provisional agenda

1958 AGREEMENT

Consideration of draft amendments to existing Regulations

Proposal for Supplement 4 to the 04 series of amendments to Regulation No. 48
(Installation of lighting and light-signalling devices)

Submitted by the Working Party on Lighting and Light-Signalling */

The text reproduced below was adopted by the Working Party on Lighting and Light-Signalling (GRE) at its sixty-first session. It is based on informal document No. GRE-61-16, as reproduced in Annex III to the report, on ECE/TRANS/WP.29/GRE/2009/3, as amended by para. 14 of the report, on ECE/TRANS/WP.29/GRE/2009/6, not amended, on ECE/TRANS/WP.29/GRE/2009/16, not amended, on ECE/TRANS/WP.29/GRE/2009/28, as amended by para. 16. of the report and on ECE/TRANS/WP.29/GRE/2009/18 as amended by Annex III to the report. It is submitted to the World Forum for Harmonization of Vehicle Regulations (WP.29) and to the Administrative Committee (AC.1) for consideration (ECE/TRANS/WP.29/GRE/61, paras. 14, 15, 16 and 20).

*/ In accordance with the programme of work of the Inland Transport Committee for 2006-2010 (ECE/TRANS/166/Add.1, programme activity 02.4), the World Forum will develop, harmonize and update Regulations in order to enhance performance of vehicles. The present document is submitted in conformity with that mandate.

Paragraph 2.7.6., insert a reference to footnote 3/ and a new footnote 3/ to read:

"2.7.6. ...a common lamp body; 3/

3/ Examples to enable a decision regarding reciprocal incorporation of lamps can be found in Annex 3, Part 7."

Paragraph 2.8., amend to read:

"2.8. "Light emitting surface" ofsee Annex 3 (See e.g. Parts 1, and 4);

...

b) ... see Annex 3. (See e.g. Part 5);"

Insert a new paragraph 2.8.1., to read:

"2.8.1. "Textured outer lens" or "Textured outer lens area" means all or part of an outer lens, designed to modify or influence the propagation of light from the light source(s), such that the light rays are significantly diverted from their original direction."

Paragraph 2.9.1., amend to read:

"2.9.1. "Illuminating surface of a lighting ... are adjustable relative to one another, the mean adjustment should be used.

In the case of AFS being installed: where a lighting function is produced by two or more simultaneously operated lighting units on a given side of the vehicle, the individual illuminating surfaces, taken together, constitute the illuminating surface to be considered (for example, in the figure of paragraph 6. 22. 4. below, the individual illuminating surfaces of the lighting units 8, 9 and 11, regarded together and taking into account their respective location, constitute the illuminating surface to be considered for the right hand side of the vehicle)."

Paragraph 2.9.2., amend to read:

"2.9.2. "Illuminating surface of a light-signalling device..... encloses a non-lighted surface, the illuminating surface may be considered to be the light emitting surface itself. (See e.g. Annex 3, Parts 2, 3, 5 and 6)"

Paragraph 2.10., amend to read:

"2. 10. The "apparent surface" for a defined direction of observation means, at the request of the manufacturer or his duly accredited representative, the orthogonal projection of:

either the boundary of the illuminating surface projected on the exterior surface of the lens;

or the light-emitting surface;

in a plane perpendicular to the direction of observation and tangential to the most exterior point of the lens. Different examples of the application of apparent surface can be found in Annex 3 to this Regulation."

Paragraphs 2.29.1. to 2.29.4. and 2.30. to 2.32.1., the reference to footnote 3/ and footnote 3/, renumber as footnote 4/

Paragraph 4.4.1., the reference to footnote 4/ and footnote 4/, renumber as footnote 5/

Paragraph 5.2.1., the reference to footnote 5/ and footnote 5/, renumber as footnote 6/

Paragraph 5.15., the reference to footnotes 6/ 7/ and 8/ and footnotes 6/ 7/ and 8/, renumber as footnotes 7/ 8/ and 9/

Paragraph 6.2.4.2., the reference to footnote 9/ and footnote 9/, renumber as footnote 10/

Paragraph 6.2.9., the reference to footnote 10/ and footnote 10/, renumber as footnote 11/

Paragraph 6.3.4.2., the reference to footnote 11/ and footnote 11/, renumber as footnote 12/

Paragraphs 6.3.5. and 6.3.6.1.1., the reference to footnote 12/ and footnote 12/, renumber as footnote 13/

Paragraph 6.5.3., amend to read:

"6.5.3. Arrangements (see figure below)

A: two front direction-indicator lamps of the following categories:

.....

5

for all M₁ vehicles;

for N₁, M₂ and M₃ vehicles not exceeding 6 metres in length.

6

for all N₂ and N₃ vehicles;

for N₁, M₂ and M₃ vehicles exceeding 6 metres in length.

It is permitted to replace Category 5 side direction-indicator lamps by Category 6 side direction-indicator lamps in all instances

A maximum of three optional Category 5 or one optional Category 6 device per side on vehicles of type M₂, M₃, N₂ and N₃ exceeding 9 m in length.

.....

B: two rear direction-indicator lamps (Categories 2a or 2b)

two optional lamps (Category 2a or 2b) on all vehicles in Categories O₂, O₃ and O₄.

A maximum of three optional Category 5 or one optional Category 6 device per side on vehicles of type O₂, O₃ and O₄ exceeding 9 m in length.

Where an AFS..."

Paragraphs 6.5.4.2.3. to 6.5.5.1., amend to read:

"6.5.4.2.3. If the structure of the vehicle and if the optional rear lamps are categories 1, 1a, 1b, 2a and 2b.

6.5.4.2.4. If optional rear lamps mandatory lamps.

6.5.4.3. In length (see figure below)

....

(b) for all other categories of vehicles if the structure of the vehicle makes it impossible to comply with the minimum angles of visibility.

Optional Category 5 side direction indicator lamps, shall be fitted, spaced evenly, along the length of the vehicle.

Optional Category 6 side direction indicator lamp shall be fitted in the area between the first and last quartiles of the length of a trailer."

6.5.5. Geometric visibility

6.5.5.1. Horizontal angles: (see figure below)

..... The vertical angle above the horizontal may be reduced to 5° if the optional rear lamps are not less than 2,100 mm above the ground.

....."

Paragraph 6.5.8., amend to read (the reference to footnote 12/ and footnote 12/, renumber as footnote 13/):

"6.5.8. Tell-tale

.....

For the optional direction-indicator lamps on motor vehicles and trailers, operating tell-tale shall not be mandatory."

Paragraph 6.14.2., amend to read:

"6.14.4.2. In height: Above the ground, not less than 250 mm nor more than 900 mm (not more than 1,200 mm if grouped with any rear lamp(s), 1,500 mm if the shape of the bodywork makes it impossible to keep within 900 mm or 1200 mm respectively). "

Paragraph 6.15.4.2., amend to read:

"6.15.4.2. In height: Above the ground, not less than 250 mm nor more than 900 mm (not more than 1,200 mm if grouped with any rear lamp(s), 1,500 mm if the shape of the bodywork makes it impossible to keep within 900 mm or 1200 mm respectively)."

Paragraph 6.17.4.2., amend to read:

"6.17.4.2. In height: Above the ground, not less than 250 mm nor more than 900 mm (not more than 1,200 mm if grouped with any lamp(s), 1,500 mm if the shape of the bodywork makes it impossible to keep within 900 mm or 1200 mm respectively or if the presence of the device is not mandatory according to paragraph 6.17.1.)."

Paragraph 6.17.4.3., amend to read:

"6.17.4.3.

However, for motor vehicles the length of which does not exceed 6 m, it is sufficient to have one side retro-reflector fitted within the first third and/or one within the last third of the vehicle length. For M₁ vehicles the length of which exceeds 6 m but does not exceed 7 m it is sufficient to have one side retro-reflector fitted not further than 3 m from the front and one within the last third of the vehicle length."

Paragraph 6.18.4.3., amend to read:

"6.18.4.3.

However, for vehicles the length of which does not exceed 6 m and for chassis-cabs it is sufficient to have one side-marker lamp fitted within the first third and/or within the last third of the vehicle length. For M₁ vehicles the length of which exceeds 6 m but does not exceed 7 m it is sufficient to have one side-marker lamp fitted not further than 3 m from the front and one within the last third of the vehicle length."

Paragraph 6.19., the reference to footnote 13/ and footnote 13/, renumber as footnote 14/

Paragraph 6.19.7.1., the reference to footnote 14/ and footnote 14/, renumber as footnote 15/

Paragraph 6.20.4.1., amend to read:

"6.20.4.1. In width: one cornering lamp shall be located on each side of the vehicle's median longitudinal plane."

Paragraphs 6.21.4.1.3. and 6.21.4.2.3., the reference to footnote 15/ and footnote 15/, renumber as footnote 16/

Paragraph 6.21.7.1., amend to read:

"6.21.7.1. Conspicuity markings shall be considered continuous if the distance between adjacent elements are as small as possible and do not exceed 50 per cent of the shortest adjacent element length. However, if the manufacturer can prove to the satisfaction of the authority responsible for type approval that it is impossible to respect the value of 50 per cent, the distance between adjacent elements may be larger than 50 per cent of the shortest adjacent element, and it shall be as small as possible and not exceed 1000 mm."

Paragraph 6.22.4.1.2., the reference to footnote 16/ and footnote 16/, renumber as footnote 17/

Paragraph 6.22.7.4.3., the reference to footnote 17/ and footnote 17/, renumber as footnote 18/

Paragraph 6.22.7.4.5., the reference to footnote 18/ and footnote 18/, renumber as footnote 19/

Paragraph 6.22.9.1., the reference to footnote 19/ and footnote 19/, renumber as footnote 20/

Annex 3, amend to read:

"Annex 3

EXAMPLES OF LAMP SURFACES, AXES, CENTRES OF REFERENCE, AND ANGLES OF GEOMETRIC VISIBILITY

These examples show some arrangements to aid the understanding of the provisions and are not intended to be design restrictive.

KEY for all examples in this Annex:

1. Illuminating surface	8. Direction of visibility
2. Axis of reference	IO Inner optical part
3. Centre of reference	LG Light guide
4. Angle of geometric visibility	L Outer lens
5. Light-emitting surface	R Reflector
6. Apparent surface based on the illuminating surface	S Light source
7a. Apparent surface based on the light-emitting surface according to paragraph 2.8.a (with outer lens)	X Not part of this function
7b. Apparent surface based on the light-emitting surface according to paragraph 2.8.b (without outer lens)	F1 Function one
	F2 Function two

PART 1 - LIGHT EMITTING SURFACE OF A LIGHT-SIGNALLING DEVICE OTHER THAN A RETRO-REFLECTOR

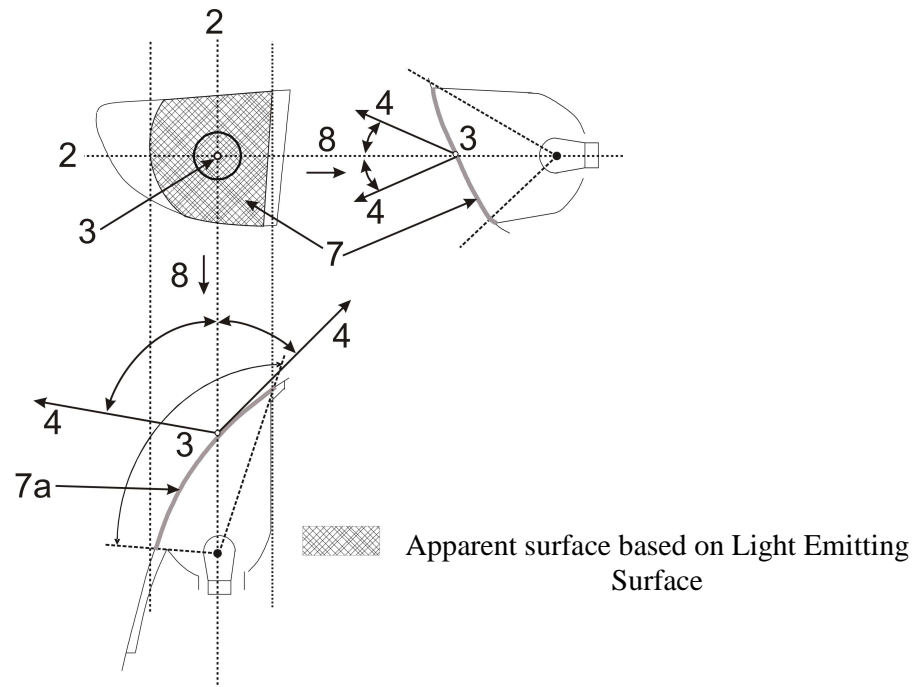

PART 2 - ILLUMINATING SURFACE OF A LIGHT-SIGNALING DEVICE OTHER THAN A RETRO-REFLECTOR

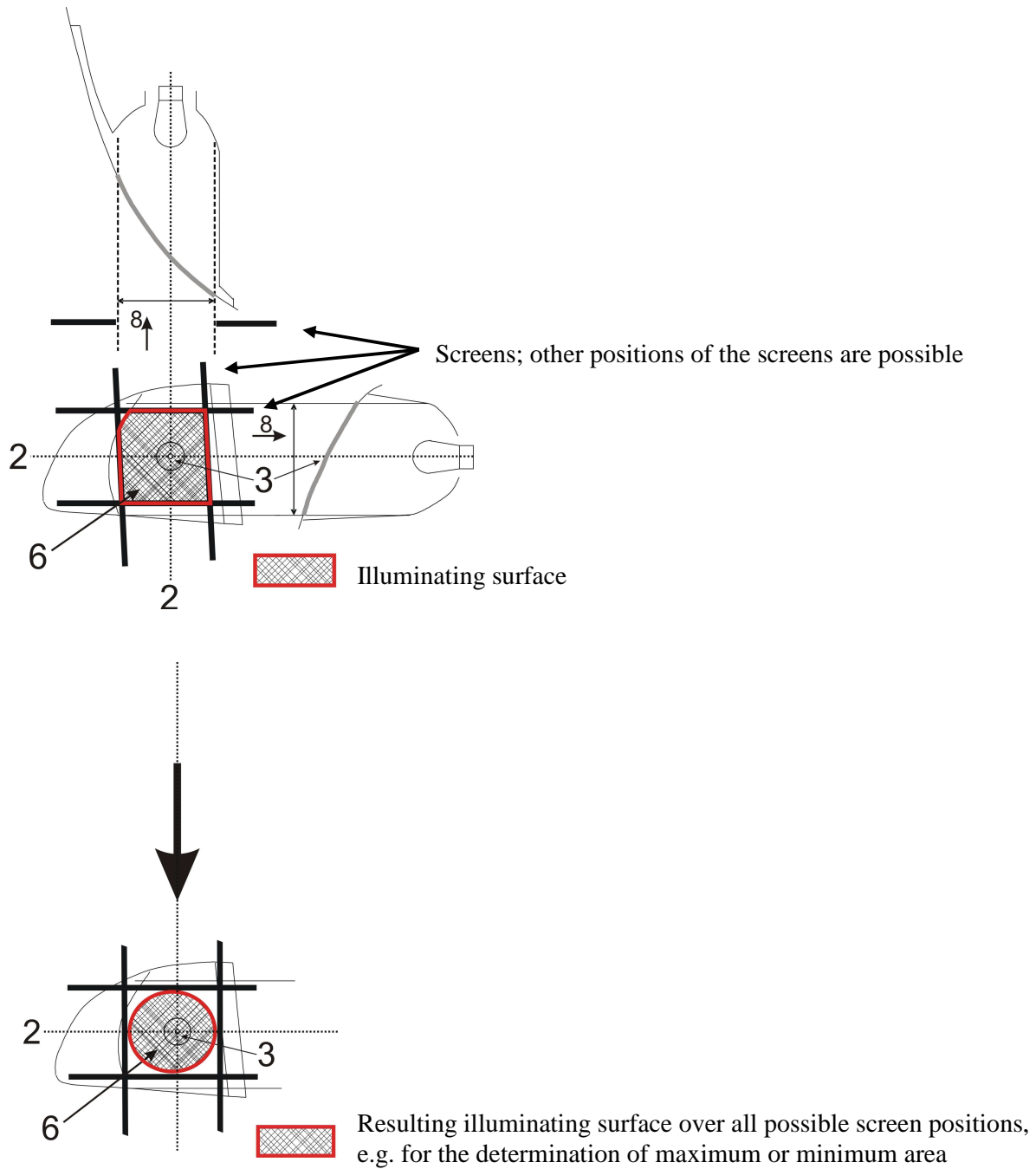

PART 3 - EXAMPLES OF APPARENT SURFACE BASED ON ILLUMINATING SURFACE IN DIFFERENT DIRECTIONS OF GEOMETRIC VISIBILITY

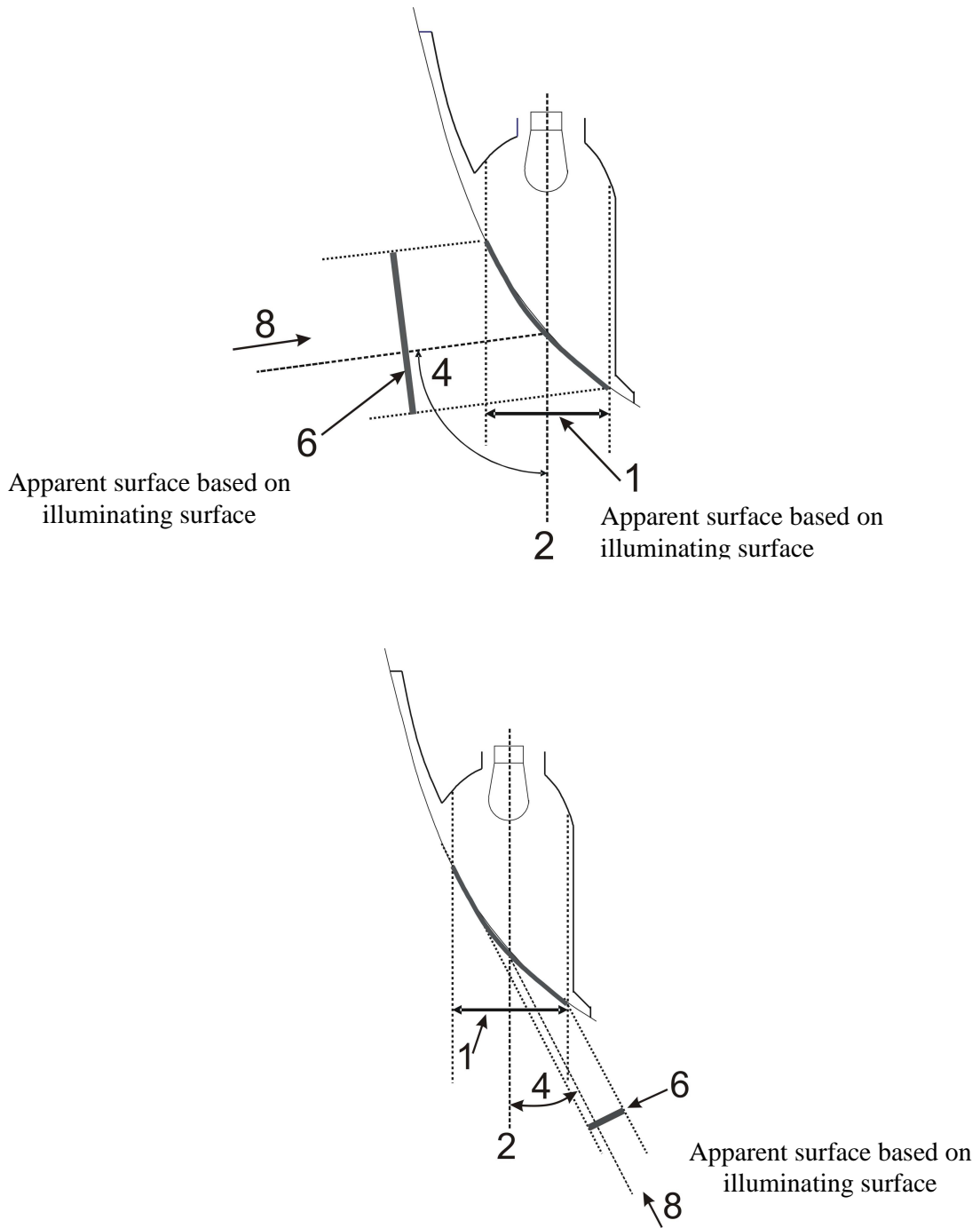

PART 4 - EXAMPLES OF APPARENT SURFACE BASED ON LIGHT EMITTING SURFACE IN DIFFERENT DIRECTIONS OF GEOMETRIC VISIBILITY

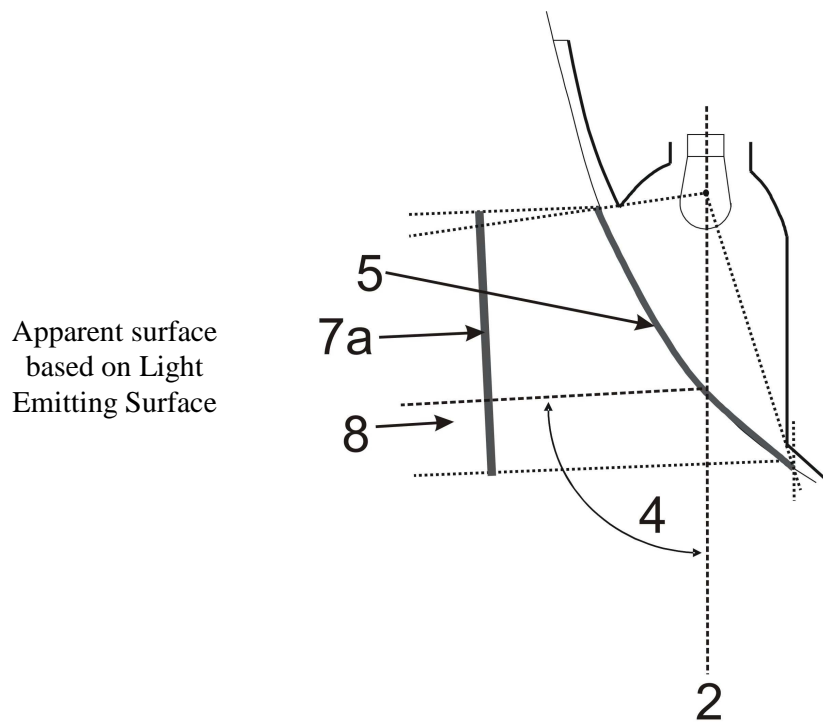
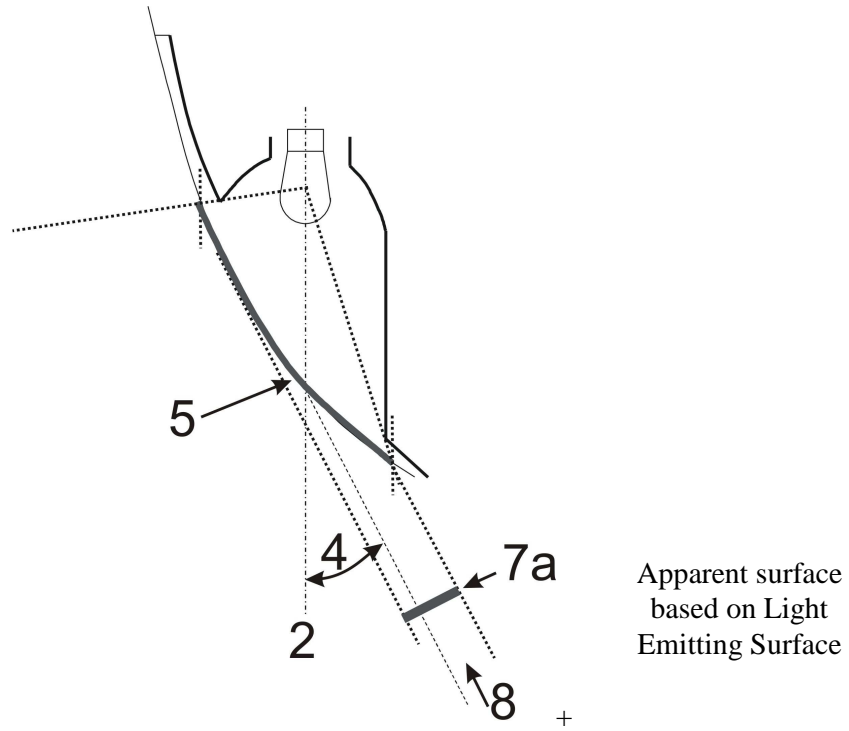

PART 5 - EXAMPLE OF ILLUMINATING SURFACE IN COMPARISON WITH LIGHT-EMITTING SURFACE IN THE CASE OF A "SINGLE FUNCTION LAMP"

(See paragraphs 2.8. to 2.9 of this Regulation)

Examples of a light source with a reflector optic behind an outer lens:

Example 1:

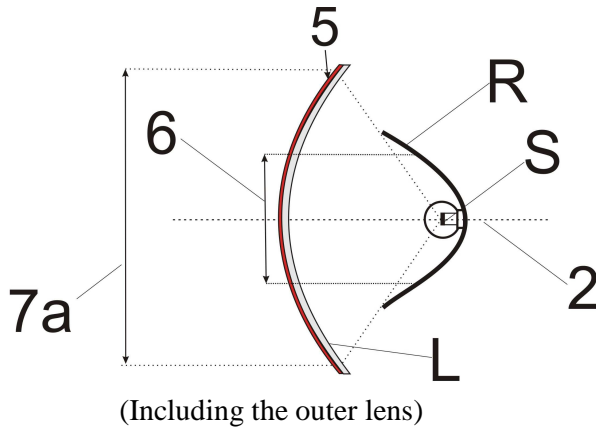

Example 2

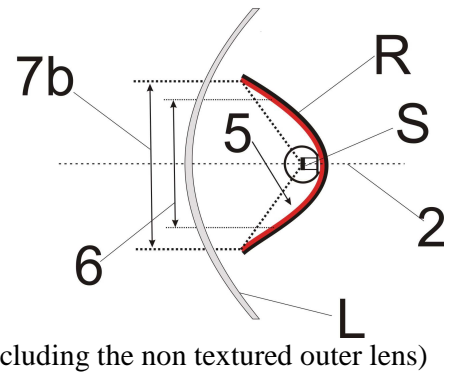

Examples of a light source with a reflector optic with a inner lens behind an outer lens:

Example 3:

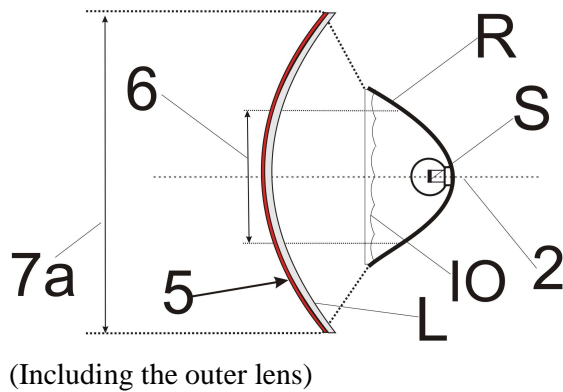

Example 4

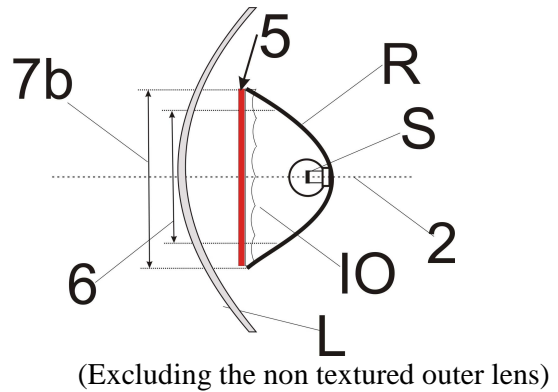

Examples of a light source with a reflector optic with a partial inner lens behind an outer lens:

Example 5:

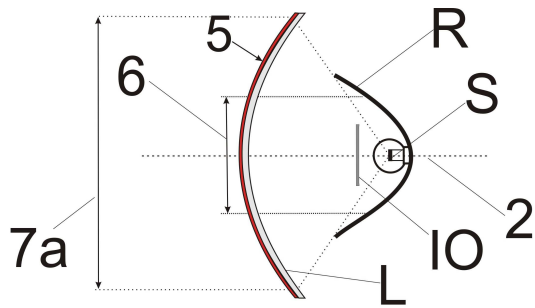

(including the outer lens)

Example 6

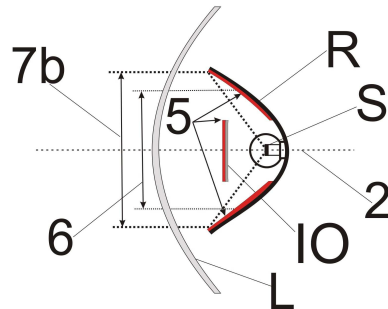

(excluding the non textured outer lens)

Example of a light guide optic behind an outer lens:

Example 7:

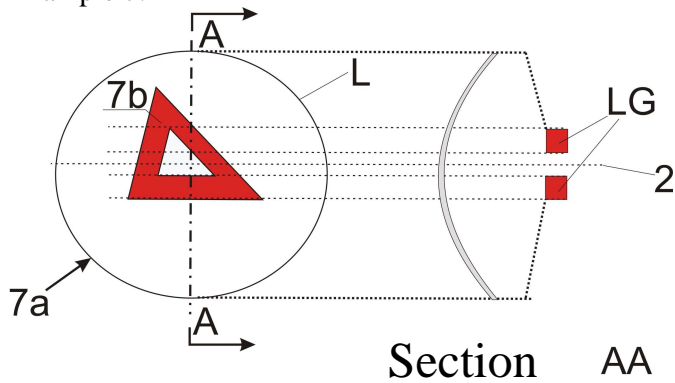

In the case where the non textured outer lens is excluded, "7b" is the apparent surface according to paragraph 2.8. b.

Example of a light guide optic or a reflector optic behind an outer lens:

Example 8:

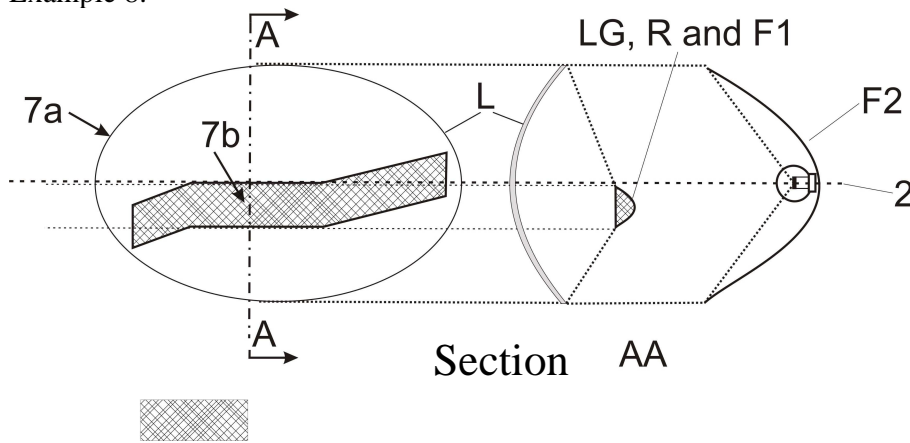

In the case where the non textured outer lens is excluded, "7b" is the apparent surface according to paragraph 2.8. b, and F1 shall not transparent to F2

Example of a light source with a reflector optic in combination with an area which is not part of this function, behind an outer lens:

Example 9:

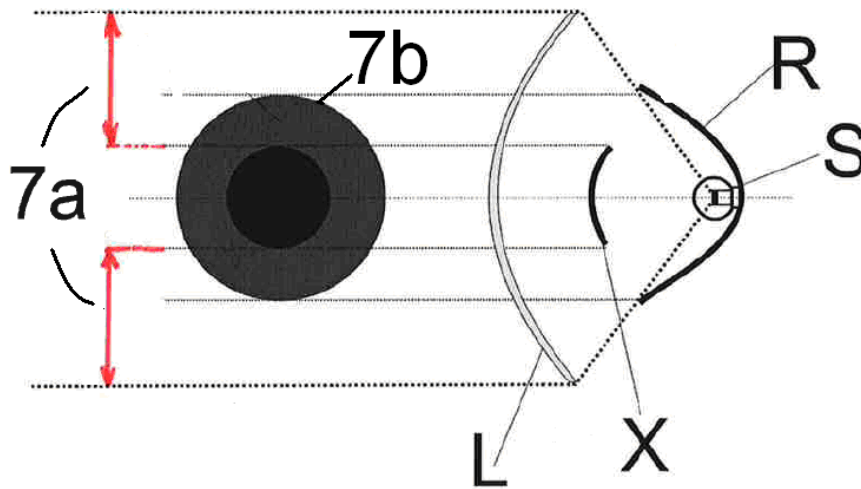

 In the case where the non textured outer lens is excluded, "7b" is the apparent surface according to paragraph 2.8. b.

PART 6 EXAMPLES SHOWING THE DETERMINATION OF THE LIGHT-EMITTING SURFACE IN COMPARISON WITH ILLUMINATING SURFACE

(See paragraphs 2. 9. and 2. 8. of this Regulation)

Note: Reflected light could / may contribute to the determination of the light emitting surface

Example A:

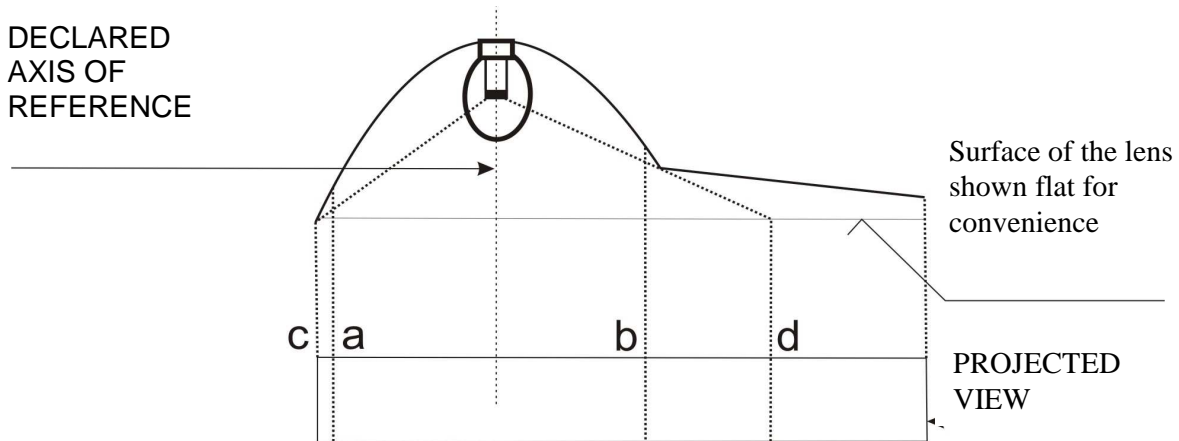

	illuminating surface	Declared Light-emitting surface according to 2.8.a
Edges are	a and b	c and d

Example B:

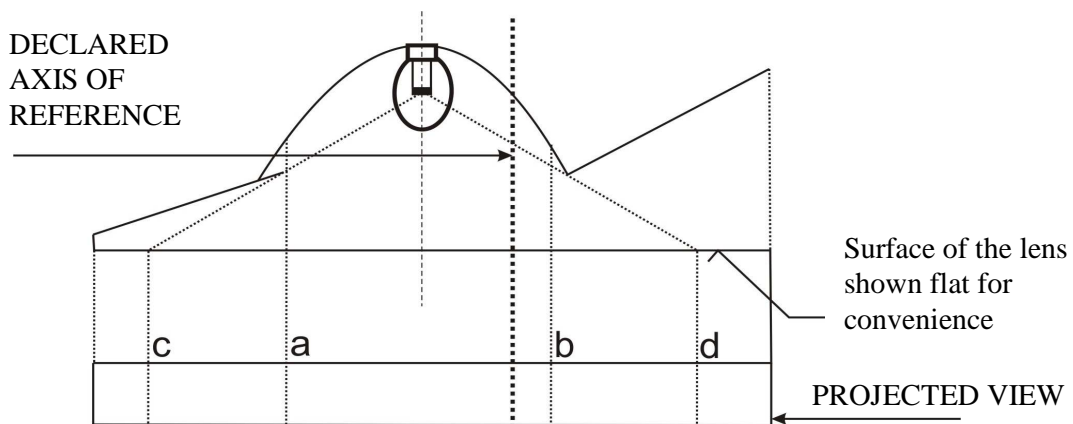

	illuminating surface	Declared Light-emitting surface according to 2.8.a
Edges are	a and b	c and d

Example C:

Example to determine the illuminating surface in combination with an area which is not part of the function:

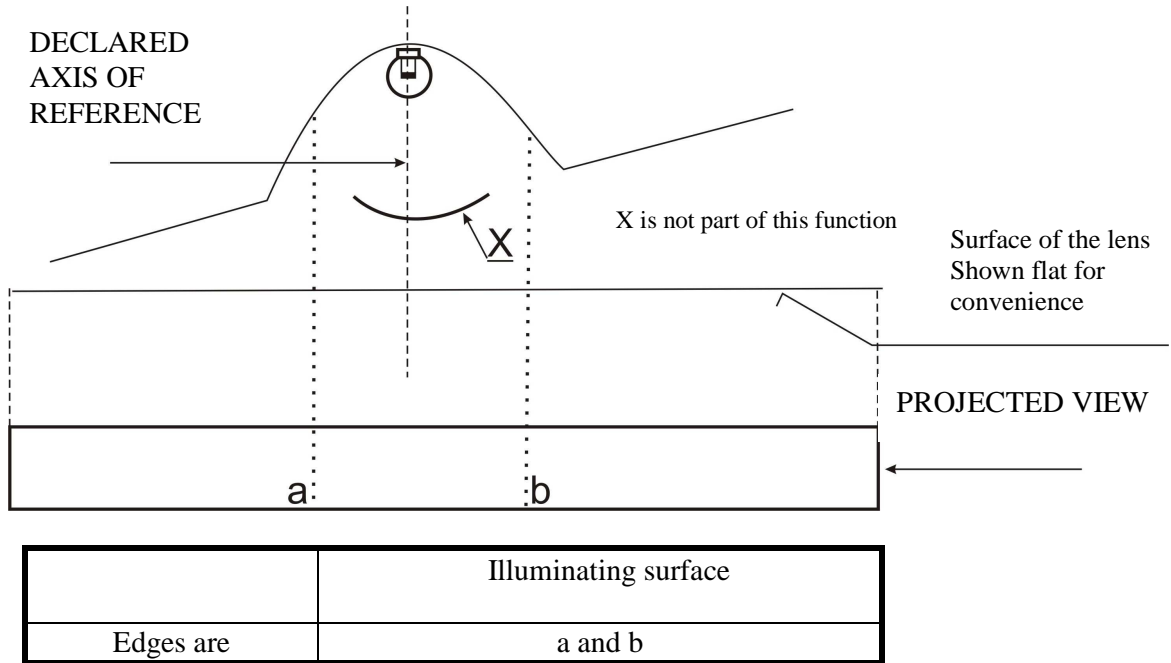

Example D:

Example to determine a light emitting surface according to 2.8.a in combination with an area which is not part of the function:

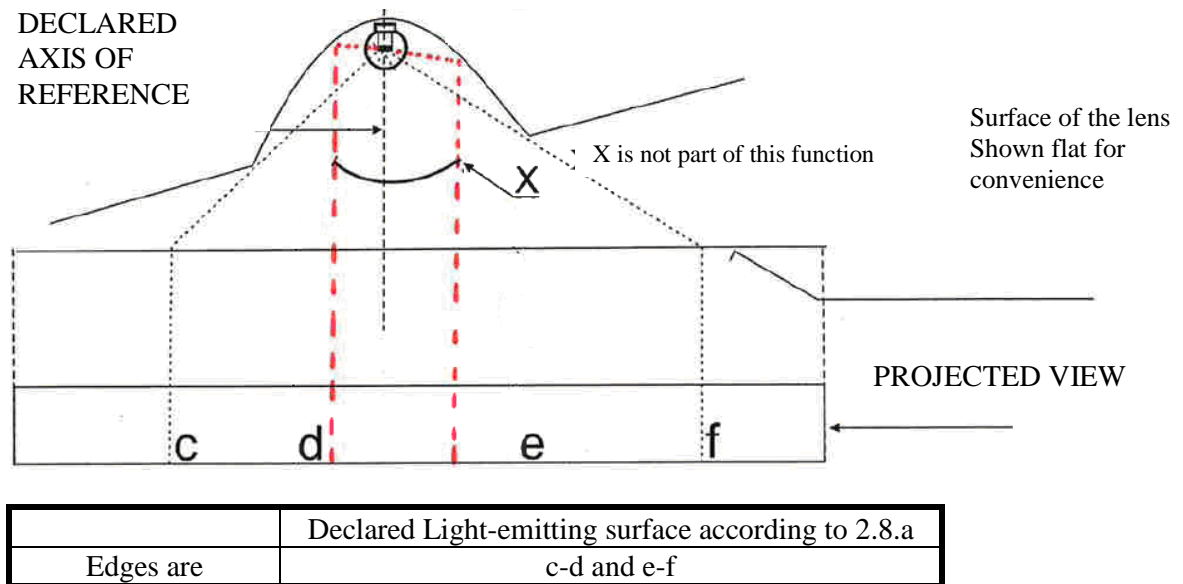

Example E:

Example to determine the apparent surface in combination with an area which is not part of the function and a non textured outer lens (according to 2.8.b):

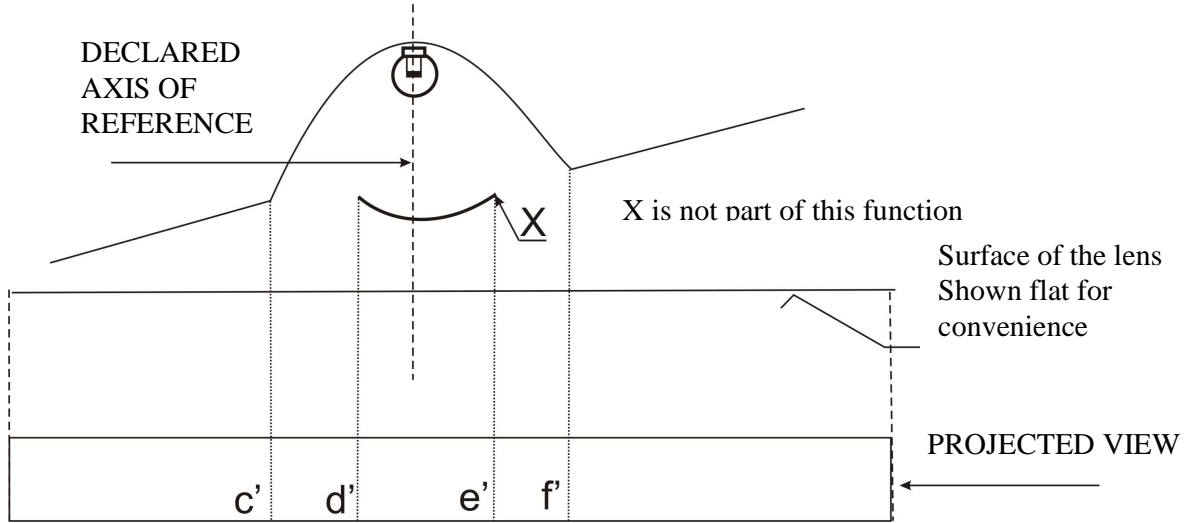

	Declared Light emitting surface according to 2.8b. For example
Edges are	c'-d' and e'-f'

PART 7 EXAMPLES TO ENABLE A DECISION REGARDING THE RECIPROCAL INCORPORATION OF TWO FUNCTIONS

In the case with a textured outer lens and a wall in between:

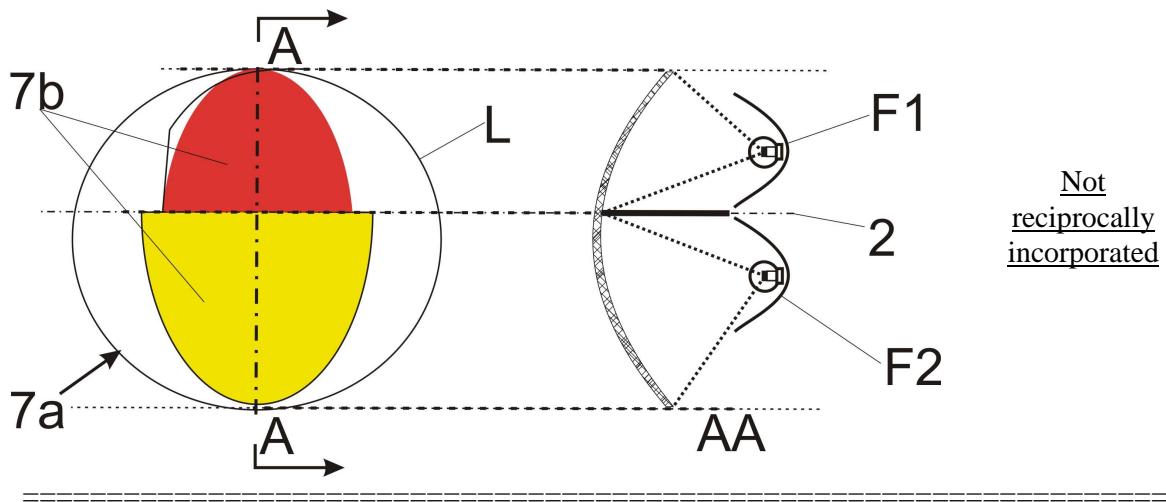

In the case with a textured outer lens:

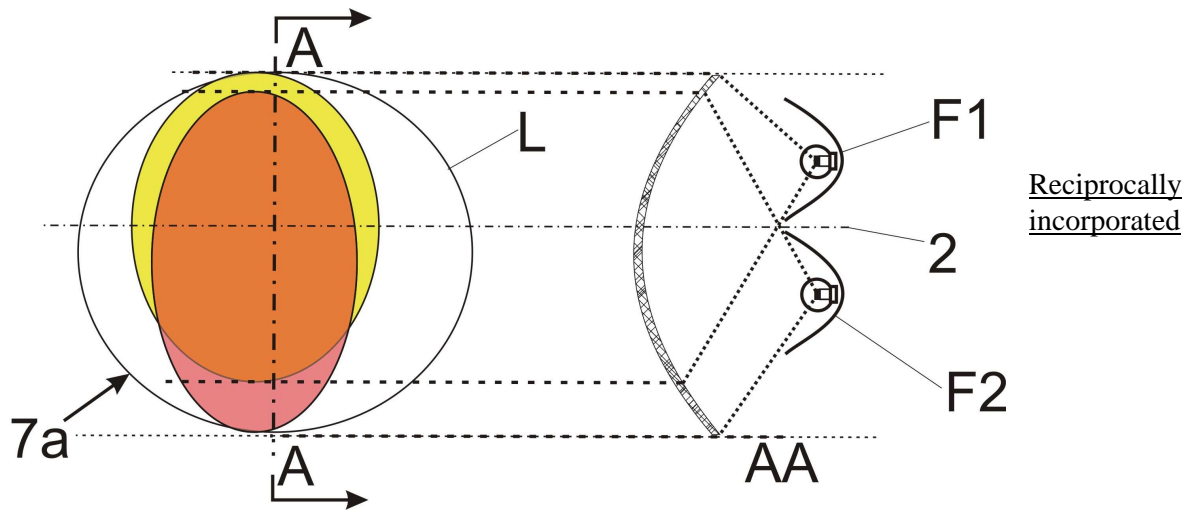

In the case where the non-textured outer lens is excluded:

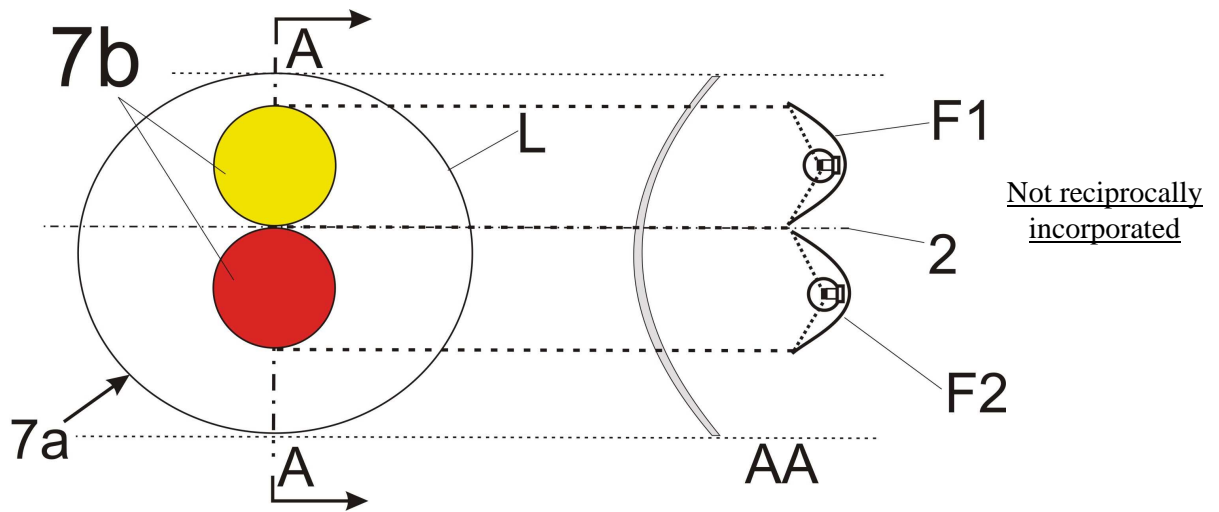

In the case where the non-textured outer lens is excluded:

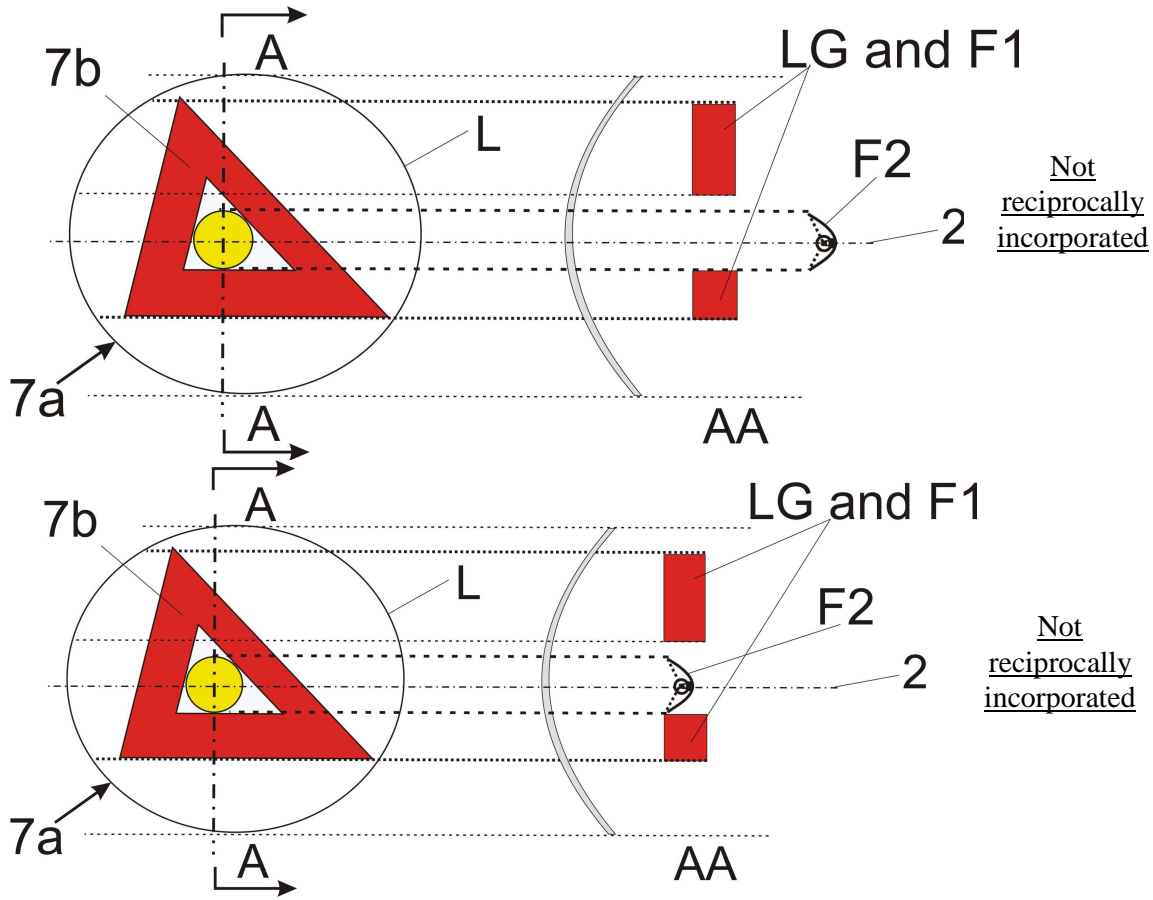

In the case where the outer lens (textured or not) is included:

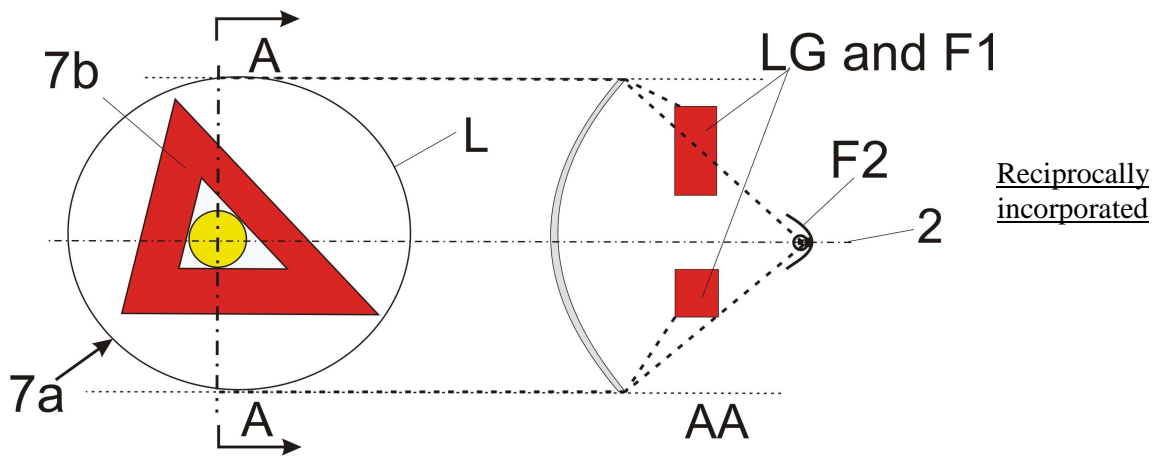

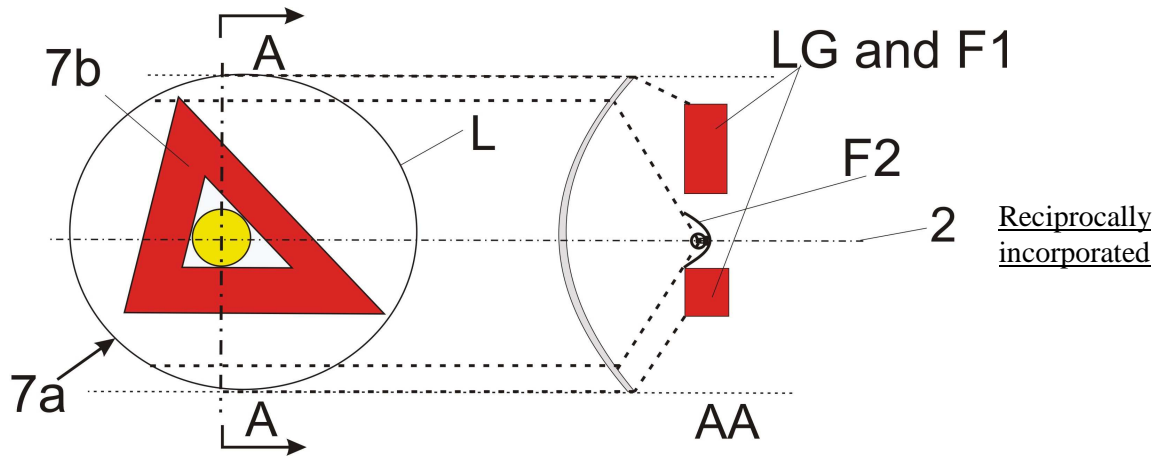

In the case where the outer lens (textured or not) is included:

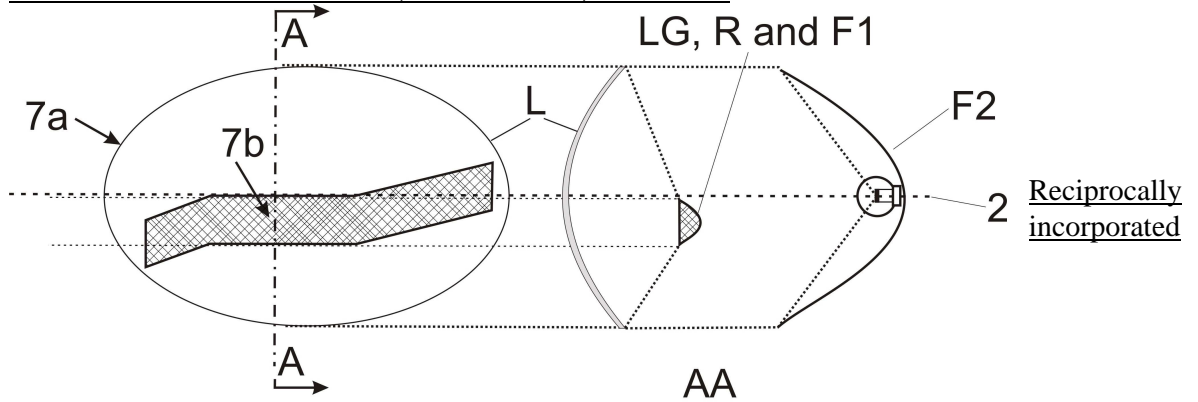

In the case where the non-textured outer lens is excluded, "7b" is the apparent surface according to paragraph 2.8 and F1 shall not be transparent to F2:

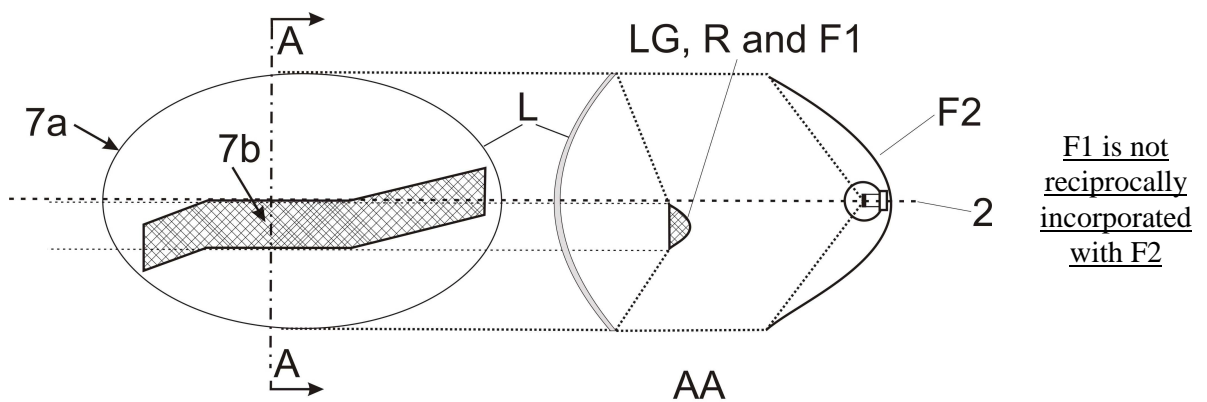

In the case where the non-textured outer lens is excluded or not:

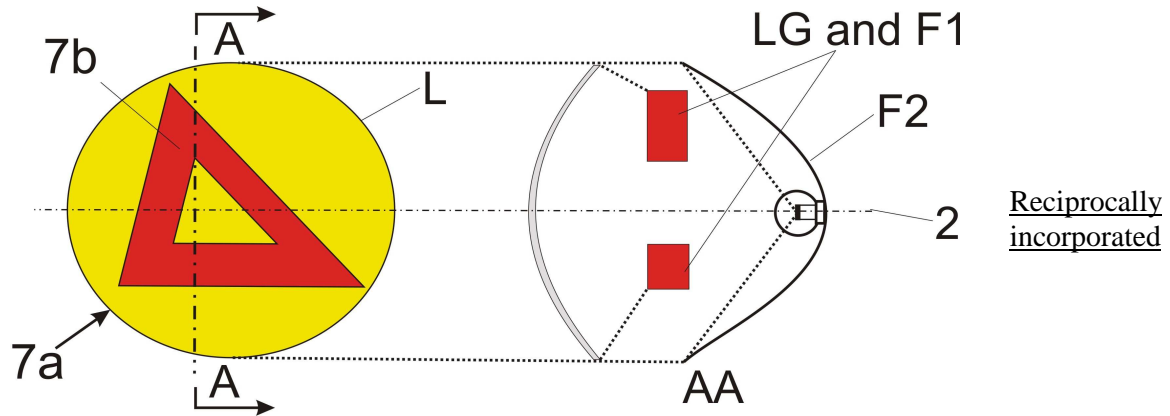

Reciprocally
incorporated

"