



**Economic and Social  
Council**

Distr.  
GENERAL

ECE/TRANS/WP.29/GRE/2009/55  
14 July 2009

Original: ENGLISH  
ENGLISH AND FRENCH ONLY

---

**ECONOMIC COMMISSION FOR EUROPE**

INLAND TRANSPORT COMMITTEE

World Forum for Harmonization of Vehicle Regulations

Working Party on Lighting and Light-Signalling

Sixty-second session

Geneva, 6 - 9 October 2009

Item 15(e) of the provisional agenda

OTHER BUSINESS

New draft Regulation on Light Emitting Diode Light Sources

Submitted by the expert from the Working Party "Brussels 1952" \*/

The text reproduced below was prepared by the expert from the Working Party "Brussels 1952" (GTB) in order to introduce uniform provisions concerning the approval of Light Emitting Diode (LED) Light Sources for use in approved signalling lamp units on power-driven vehicles and their trailers. The document is based on the current text of Regulations Nos. 37 and 99. The modifications to the existing text of the two Regulations are marked in bold characters.

---

\*/ In accordance with the programme of work of the Inland Transport Committee for 2006-2010 (ECE/TRANS/166/Add.1, programme activity 02.4), the World Forum will develop, harmonize and update Regulations in order to enhance performance of vehicles. The present document is submitted in conformity with that mandate.

A. PROPOSAL

CONTENTS

REGULATION	<u>Page</u>
1. Scope.....	4
2. Administrative provisions .....	4
2.1. Definitions .....	4
2.2. Application for approval .....	4
2.3. Inscriptions .....	5
2.4. Approval.....	5
3. Technical requirements .....	7
3.1. Definitions .....	7
3.2. General specifications .....	8
3.3. Tests .....	8
3.4. Position and dimensions of apparent light emitting area .....	8
3.5. Luminous flux .....	8
3.6. Normalised luminous intensity distribution .....	9
3.7. Colour.....	9
3.8. UV radiation .....	10
3.9. Standard LED light sources .....	10
4. Conformity of production .....	12
5. Penalties for non-conformity of production .....	11
6. Production definitely discontinued .....	12
7. Names and addresses of technical services responsible for conducting approval tests, and of administrative departments .....	12

## CONTENTS (continued)

ANNEXES	<u>page</u>
<u>Annex 1</u> : Sheets for LED light sources .....	13
<u>Annex 2</u> : Communication concerning the approval or extension or refusal or withdrawal of approval or production definitely discontinued of a type of LED light source pursuant to Regulation No. xx.....	19
<u>Annex 3</u> : Example of the arrangement of the approval mark .....	21
<u>Annex 4</u> : Method of measurement of electrical and photometrical characteristics .....	22
<u>Annex 5</u> : Minimum requirements for quality procedures by the manufacturer.....	24
<u>Annex 6</u> : Sampling and compliance levels for manufacturer test records.....	26
<u>Annex 7</u> : Minimum requirements for spot checks by the administrative authority .....	30
<u>Annex 8</u> : Compliance approved by spot check .....	31

1. SCOPE

This Regulation applies to LED light sources shown in Annex 1 and intended for use in approved signalling lamp units of power-driven vehicles and of their trailers.

2. ADMINISTRATIVE PROVISIONS

2.1. Definitions

2.1.1. Definition of "category"

The term "category" is used in this Regulation to describe different basic design of standardised **LED** light sources. Each category has a specific designation as for example: "**LW1**", "**LY2**", "**LR2**".

2.1.2. Definition of "type"

**LED** light sources of different "types" are **LED** light sources within the same category which differ in such essential respects as:

2.1.2.1. trade name or mark;

**LED** light sources bearing the same trade name or mark but produced by different manufacturers are considered as being of different types. **LED** light sources produced by the same manufacturer differing only by the trade name or mark may be considered to be of the same type.

2.1.2.2. light source design, in so far as these differences affect the optical results;

2.1.2.3. rated voltage.

2.2. Application for approval

2.2.1. Application for approval shall be submitted by the owner of the trade name or mark, or by his duly accredited representative.

2.2.2. Every application for approval shall be accompanied (see also paragraph 2.4.2.) by:

2.2.2.1. drawings in triplicate, sufficiently detailed to permit identification of the type;

2.2.2.2. a brief technical description;

2.2.2.3. five samples of each colour which has been applied for;

2.2.3. In the case of a type of **LED** light sources differing only by the trade name or mark from a type that has already been approved it shall be sufficient to submit:

2.2.3.1. a declaration by the manufacturer that the type submitted

- (a) **is identical with (except in the trade name or mark), and**
- (b) **has been produced by the same manufacturer as the type already approved, the latter being identified by its approval code.**

2.2.3.2. two samples bearing the new trade name or mark.

2.2.4. The competent authority shall verify the existence of satisfactory arrangements for ensuring effective control of the conformity of production before type approval is granted.

### 2.3. Inscriptions

2.3.1. **LED** light sources submitted for approval shall bear on the cap:

2.3.1.1. the trade name or mark of the applicant;

2.3.1.2. the rated voltage.;

2.3.1.3. the designation of the relevant category.;

2.3.1.4. a space of sufficient size to accommodate the approval mark.

2.3.2. The space mentioned in paragraph 2.3.1.4. above shall be indicated in the drawings accompanying the application for approval.

2.3.3. Inscriptions other than those covered by paragraphs 2.3.1. and 2.4.4. may be affixed, on the condition that they do not adversely affect the luminous characteristics.

### 2.4. Approval

2.4.1. If all samples of a type of **LED** light source which are submitted in pursuance of paragraphs 2.2.2.3. or 2.2.3.2. above meet the requirements of this Regulation, approval shall be granted.

2.4.2. An approval code shall be assigned to each type approved. Its first character shall indicate the series of amendments at the time of issue of the approval. This will be followed by an identification code comprising not more than two characters. Only the following Arabic numerals and capital letters shall be used:

**"0 1 2 3 4 5 6 7 8 9 A B C D E F G H J K L M N P R S T U V W X Y Z".**

The same Contracting Party may not assign the same code to another type of **LED** light sources.

2.4.3 Notice of approval or of extension or refusal or withdrawal of approval or production definitely discontinued of a type of **LED** light sources pursuant to this Regulation shall be communicated to the Parties of the Agreement which apply this Regulation by means of a form conforming to the model in Annex 2 to this Regulation and of a drawing, supplied by the applicant for approval in a format not exceeding A4 (210 x

297 mm) and on a scale of at least 2 : 1.

- 2.4.4. To every **LED** light source conforming to a type approved under this Regulation there shall be affixed in the space referred to in paragraph 2.3.1.4., in addition to the inscriptions required under paragraph 2.3.1., an international approval mark consisting of:
- 2.4.4.1. a truncated circle surrounding the letter "E" followed by the distinguishing number of the country which has granted approval; 1/
- 2.4.4.2. the approval code, placed close to the truncated circle.
- 2.4.5. If the applicant has obtained the same approval code for several trade names or marks, one or more of them will suffice to meet the requirements of paragraph 2.3.1.1.
- 2.4.6. The marks and inscriptions specified in paragraphs 2.3.1. and 2.4.3. shall be clearly legible and be indelible.
- 2.4.7. Annex 3 to this Regulation gives an example of arrangement of the approval mark.

---

1/ 1 for Germany, 2 for France, 3 for Italy, 4 for the Netherlands, 5 for Sweden, 6 for Belgium, 7 for Hungary, 8 for the Czech Republic, 9 for Spain, 10 for Serbia and Montenegro, 11 for the United Kingdom, 12 for Austria, 13 for Luxembourg, 14 for Switzerland, 15 (vacant), 16 for Norway, 17 for Finland, 18 for Denmark, 19 for Romania, 20 for Poland, 21 for Portugal, 22 for the Russian Federation, 23 for Greece, 24 for Ireland, 25 for Croatia, 26 for Slovenia, 27 for Slovakia, 28 for Belarus, 29 for Estonia, 30 (vacant), 31 for Bosnia and Herzegovina, 32 for Latvia, 33 (vacant), 34 for Bulgaria, 35 (vacant), 36 for Lithuania, 37 for Turkey, 38 (vacant), 39 for Azerbaijan, 40 for The former Yugoslav Republic of Macedonia, 41 (vacant), 42 for the European Community (Approvals are granted by its Member States using their respective ECE symbol), 43 for Japan, 44 (vacant), 45 for Australia, 46 for Ukraine, 47 for South Africa, 48 for New Zealand, 49 for Cyprus, 50 for Malta and 51 for the Republic of Korea, 52 for Malaysia, 53 for Thailand, 54 and 55 (vacant), 56 for Montenegro and 58 for Tunisia. Subsequent numbers shall be assigned to other countries in the chronological order in which they ratify or accede to the Agreement Concerning the Adoption of Uniform Technical Prescriptions for Wheeled Vehicles, Equipment and Parts which can be Fitted and/or be Used on Wheeled Vehicles and the Conditions for Reciprocal Recognition of Approvals Granted on the Basis of these Prescriptions, and the numbers thus assigned shall be communicated by the Secretary-General of the United Nations to the Contracting Parties to the Agreement.

### 3. TECHNICAL REQUIREMENTS

#### 3.1. Definitions

- 3.1.1. Rated voltage: voltage (in volts) marked on the **LED** light source;
- 3.1.2. Test voltage(s): voltage(s) or voltage range(s), at the **LED** light sources terminals for which the electrical and photometric characteristics of the **LED** light sources are intended and are to be tested.
- 3.1.3. Objective values: Design value of an electrical or photometric characteristic. To be achieved, within the specified tolerances, when the **LED** light source is energized at relevant test voltage.
- 3.1.4. Standard (étalon) **LED** light source: Special **LED** light source used for the testing of lighting and light-signalling devices. It has reduced tolerances for dimensional, electrical and photometric characteristics as specified on the relevant data sheet. Standard **LED** light sources are specified in only one voltage rating for each category.
- 3.1.5. Reference axis: an axis defined with reference to the cap and to which certain dimensions of the **LED** light sources are referred;
- 3.1.6. Reference plane: a plane defined with reference to the cap perpendicular to the reference axis and to which certain dimensions of the **LED** light sources are referred.
- 3.1.7. Light centre: a point on the reference axis at a defined distance from the reference plane that represents the nominal origin of the visible radiation emitted.
- 3.1.8. Light centre length: the distance between the reference plane and the light centre
- 3.1.9. Viewing axis on to the **LED** light source: an axis through the light centre at defined polar and azimuthal angle used to characterize photometrical properties of the **LED** light source.
- 3.1.10. Apparent light emitting area: area that contains the (apparent) element of visible radiation when observed under a certain viewing axis. The apparent light emitting area is defined in a plane that contains the light centre and that is perpendicular to the corresponding viewing axis
- 3.1.11. Normalized luminous intensity: luminous intensity divided by the luminous flux of the light source in order to characterize the angular radiation pattern of the **LED** light source.

3.2. General specifications

- 3.2.1. Each sample submitted shall conform to the relevant specifications of this Regulation.
- 3.2.2. **LED** light sources shall be so designed as to be and to remain in good working order when in normal use. They shall moreover exhibit no fault in design or manufacture.
- 3.2.3. **LED** light sources shall exhibit no scores or spots on their optical surfaces which might impair their efficiency and their optical performance.
- 3.2.4. **LED** light sources shall be equipped with standard caps complying with the cap data sheets of IEC Publication 60061 as specified on the individual data sheets of Annex 1.
- 3.2.5. **The cap shall be strong and firmly secured to the rest of the LED light source.**
- 3.2.6. **To ascertain whether LED light sources conform to the requirements of paragraphs 3.2.3. to 3.2.5. above, a visual inspection, a dimension check and, where necessary, a trial fitting into the holder as specified in IEC publication 60061 shall be carried out.**

3.3. Tests

- 3.3.1. **LED** light sources shall first be aged at their test voltage for at least forty-eight hours. For multi-function **LED** light sources, each function shall be aged separately.
- 3.3.2. Unless otherwise specified, electrical and photometric measurements shall be carried out at the relevant test voltage(s).
- 3.3.3. Electrical measurements as specified in Annex 4 shall be carried out with instruments of at least class 0.2 (0.2 per cent full scale accuracy).

3.4. Position and dimensions of apparent light emitting area

- 3.4.1. **The position and dimensions of the apparent light emitting area shall conform to the requirements as given on the relevant data sheet of Annex 1.**
- 3.4.2. **The measurement shall be made after ageing the LED light source according to 3.3.1.**

3.5. Luminous flux

- 3.5.1. **When measured according to the conditions specified in Annex 4, the luminous flux shall be within the limits given on the relevant data sheet of Annex 1.**



3.5.2. The measurement shall be made after ageing the LED light source according to 3.3.1.

### 3.6. Normalized luminous intensity distribution

3.6.1. When measured according to the test conditions specified in Annex 4, the normalized luminous intensity distribution shall be within the limits given on the relevant data sheet of annex 1.

3.6.2. The measurement shall be made after ageing the LED light source according to 3.3.1.

### 3.7. Colour

3.7.1. The colour of the light emitted by the LED light sources shall be specified on the relevant data sheet. The definitions of the colour of the light emitted given in Regulation No. 48 and its series of amendments in force at the time of application for type approval shall apply to this regulation.

3.7.2. The colour of the light emitted shall be measured by the method specified in Annex 4. Each measured value shall lie within the required tolerance area.

3.7.3. Moreover, in the case of LED light sources emitting white light, the minimum red content of the light shall be such that:

$$k_{red} = \frac{\int_{\lambda=610nm}^{780nm} E_e(\lambda) V(\lambda) d\lambda}{\int_{\lambda=380nm}^{780nm} E_e(\lambda) V(\lambda) d\lambda} \geq 0,05$$

where:

$E_e(\lambda)$  (unit: W) is the spectral distribution of the irradiance;  
 $V(\lambda)$  (unit: 1) is the spectral luminous efficiency;  
 $\lambda$  (unit: nm) is the wavelength.

This value shall be calculated using intervals of one nanometer.

### 3.8. UV-radiation

The UV-radiation of the LED light source shall be such that the LED light source is of the low UV type complying with:

$$k_{UV} = \frac{\int_{\lambda=250nm}^{400nm} E_e(\lambda) S(\lambda) d\lambda}{k_m \int_{\lambda=380nm}^{780nm} E_e(\lambda) V(\lambda) d\lambda} \leq 10^{-5} W / lm$$

where:

$S(\lambda)$ (unit: 1) is the spectral weighting function;

$k_m = 683 \text{ lm/W}$  is the maximum value of the luminous efficacy of radiation.

(For definitions of the other symbols see paragraph 3.7.3. above).

This value shall be calculated using intervals of one nanometer. The UV-radiation shall be weighted according to the values as indicated in the Table below:

$\lambda$	$S(\lambda)$	$\lambda$	$S(\lambda)$	$\lambda$	$S(\lambda)$
250	0.430	305	0.060	355	0.000 16
255	0.520	310	0.015	360	0.000 13
260	0.650	315	0.003	365	0.000 11
265	0.810	320	0.001	370	0.000 09
270	1.000	325	0.000 50	375	0.000 077
275	0.960	330	0.000 41	380	0.000 064
280	0.880	335	0.000 34	385	0.000 530
285	0.770	340	0.000 28	390	0.000 044
290	0.640	345	0.000 24	395	0.000 036
295	0.540	350	0.000 20	400	0.000 030
300	0.300				

**Note:** Values according to "IRPA/INIRC Guidelines on limits of exposure to ultraviolet radiation". Wavelengths (in nanometers) chosen are representative; other values should be interpolated.

### 3.9. Standard LED light sources

Additional requirements for standard (étalon) LED light sources are given on the relevant data sheets of Annex 1.

4. CONFORMITY OF PRODUCTION

- 4.1. **LED** light sources approved to this Regulation shall be so manufactured as to conform to the type approved by meeting the inscriptions and technical requirements set forth in paragraph 3. above and Annexes 1, 4 and 5 to this Regulation.
- 4.2. In order to verify that the requirements of paragraph 4.1. are met, suitable controls of the production shall be carried out.
- 4.3. The holder of the approval shall in particular:
- 4.3.1. ensure existence of procedures for the effective control of the quality of products,
- 4.3.2. have access to the control equipment necessary for checking the conformity to each approved type,
- 4.3.3. ensure that data of test results are recorded and that related documents shall remain available for a period to be determined in accordance with the administrative service,
- 4.3.4. analyse the results of each type of test, applying criteria of Annex 6, in order to verify and ensure the stability of the product characteristics making allowance for variation of an industrial production,
- 4.3.5. ensure that for each type of **LED** light source, at least the tests prescribed in Annex 5 to this Regulation are carried out,
- 4.3.6. ensure that any collecting of samples giving evidence of non-conformity with the type of test considered shall give rise to another sampling and another test. All the necessary steps shall be taken to re-establish the conformity of the corresponding production.
- 4.4. The competent authority which has granted type-approval may at any time verify the conformity control methods applicable to each production unit.
- 4.4.1. In every inspection, the test books and production survey records shall be presented to the visiting inspector.
- 4.4.2. The inspector may take samples at random which will be tested in the manufacturer's laboratory. The minimum number of samples may be determined according to the results of the manufacturer's own verification.
- 4.4.3. When the quality level appears unsatisfactory or when it seems necessary to verify the validity of the tests carried out in application of paragraph 4.4.2. above, the inspector shall select samples, to be sent to the technical service which has conducted the type approval tests.
- 4.4.4. The competent authority may carry out any tests prescribed in this Regulation.

Where the competent authority decides to carry out spot checks, criteria of Annexes 7 and 8 to this Regulation shall be applied.

- 4.4.5. The normal frequency of inspection authorised by the competent authority shall be one every two years. In the case where negative results are recorded during one of these visits, the competent authority shall ensure that all necessary steps are taken to re-establish the conformity of production as rapidly as possible.

## 5. PENALTIES FOR NON-CONFORMITY OF PRODUCTION

- 5.1. The approval granted in respect of a **LED** light source pursuant to this Regulation may be withdrawn if the requirements are not met or if a **LED** light source bearing the approval mark does not conform to the type approved.

- 5.2. If a Contracting Party to the Agreement applying this Regulation withdraws an approval it has previously granted, it shall forthwith so notify the other Contracting Parties applying this Regulation, by means of a communication form conforming to the model in Annex 2 to this Regulation.

## 6. PRODUCTION DEFINITELY DISCONTINUED

If the holder of the approval completely ceases to manufacture a type of **LED** light source approved in accordance with this Regulation, he shall so inform the authority which has granted the approval. Upon receiving the relevant communication, that authority shall inform thereof the other Parties to the 1958 Agreement applying this Regulation by means of a communication form conforming to the model in Annex 2 to this Regulation.

## 7. NAMES AND ADDRESSES OF THE TECHNICAL SERVICES RESPONSIBLE FOR CONDUCTING APPROVAL TESTS, AND OF ADMINISTRATIVE DEPARTMENTS

The Parties to the 1958 Agreement which apply this Regulation shall communicate to the United Nations secretariat the names and addresses of the technical services responsible for conducting approval tests and of the administrative departments which grant approval and to which forms certifying approval or extension or refusal or withdrawal of approval, or production definitely discontinued issued in other countries, are to be sent.

Annex 1

**SHEETS \*/ FOR LED LIGHT SOURCES**

**List of categories of LED light sources and their sheet numbers:**

<u>Category</u>	<u>Sheet number(s)</u>
LR1	LR1/1 to 5

**List of sheets for LED light sources and their sequence in this annex:**

<u>Sheet number(s)</u>
LR1/1 to 5

---

**\*/ Tables, Electrical and Photometric characteristics:**  
**Voltage is expressed in V;**  
**Wattage is expressed in W;**  
**Luminous flux is expressed in lm;**  
**Normalized luminous intensity is expressed in cd/1000lm.**

The drawings are intended only to illustrate the essential dimensions (in mm) of the LED light source

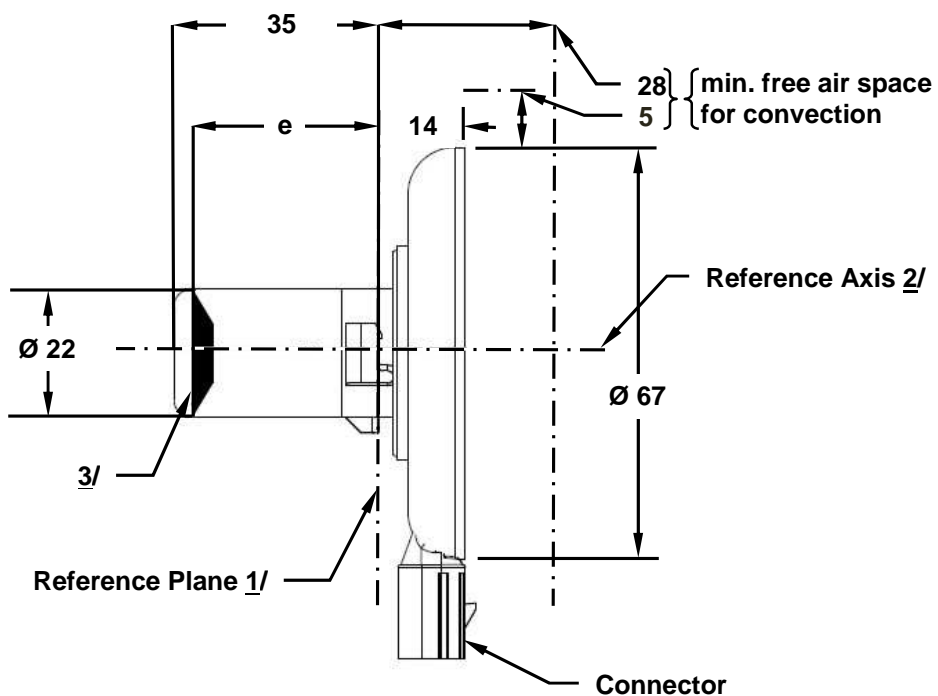

Figure 1 – Main Drawing

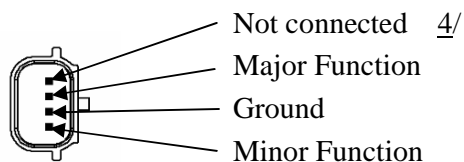

Figure 2 – Connector Detail

- 1/** The reference plane is the plane defined by the contact points of the cap-holder fit.
- 2/** The reference axis is perpendicular to the reference plane and passing through the centre of the bayonet core.
- 3/** Light emitting area: to be checked by means of the box system in Figure 3.
- 4/** Optional pin.

Dimensions in mm		Tolerance			
		LED light sources of normal production		Standard LED light source	
e 3/	24.0	0.2		0.1	
Cap PGJ22t-1 in accordance with IEC Publication 60061 (sheet 7004-....-1)					
ELECTRICAL AND PHOTOMETRIC CHARACTERISTICS					5/
Rated values		Minor function	Major function	Minor function	Major function
	Volts	12		12	
Objective Values 6/	Watts at test voltage of 13.5 V DC	0.75 max.	3.5 max. 1.4 min.	0.75 max.	3.5 max. 1.4 min.
	Voltage range	10 – 16 V DC			
	Luminous flux in lm (10-16 V DC)	3.5 ± 20%	47 ± 20%		
Reference luminous flux in lm at test voltage of 13.5V DC 6/				3.5 ± 10%	47 ± 10%

Table 1 – the table is intended to specify the essential electrical and photometric characteristics of the LED light source (LR1)

#### Failure condition behaviour

In case of LED light source failure (no light emitted) the maximum current draw – when operated within the input voltage range in major function mode – operation shall be less than 20 mA (open circuit condition).

#### Screen projection requirements

The following test is intended to define the requirements for the apparent light emitting area of the LED light source and to determine whether the light emitting area is correctly positioned relative to the reference axis and reference plane in order to check compliance with the requirements.

The position of the light emitting area is checked by the box system defined in figure 3, which shows the projections when viewing along direction  $\gamma=90^\circ$  in the planes  $C_{90}$  and  $C_{180}$  ( $C$ ,  $\gamma$  as defined in Figure 4). At least 95 per cent of the luminous flux emitted into the viewing direction has to come from the trapezoidal area defined by d1, d2 and c. Less than 70 per cent of the luminous flux shall be emitted from the rectangular area defined by d3 and c.

5/ The emitted light shall be red.

6/ Continuous on for 30 minutes at  $23 \pm 2.5^\circ$  C.

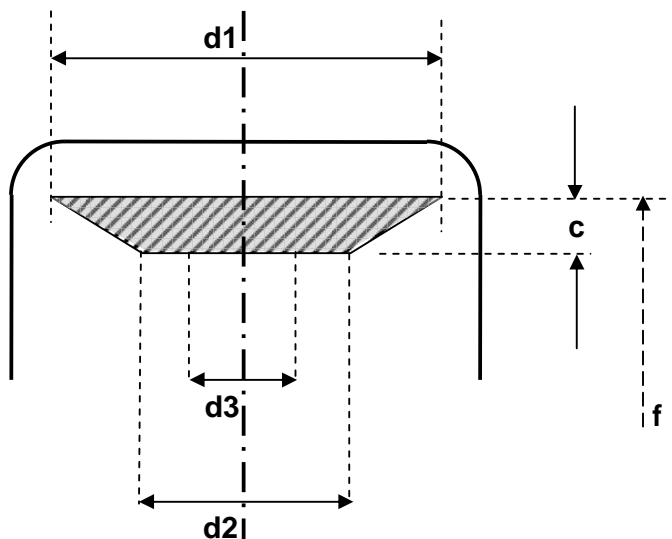

Figure 3 – Box definition of the light emitting area

Dimensions in mm	f	c	d1	d2	d3
LED light sources of normal production	e+0.2	3.6	21.0	15.0	7.0
Standard (Etalon) LED light sources	e+0.1	3.4	21.0	15.0	7.0

Table 2 – Dimensions of the box system in Figure 3

**Normalized luminous intensity distribution**

The following test is intended to determine the normalized luminous intensity distribution of the light source in an arbitrary plane containing the reference axis. The intersection of the reference axis and the upper edge of the box is used as the coordinate system origin.

The light source is mounted on a flat plate with the corresponding mounting lug features. The plate is mounted to the goniometer table by a bracket, so that the reference axis of the light source lines up with one of the rotating axis of the goniometer. The corresponding measurement set-up is described in Figure 4.



The drawings are intended only to illustrate the essential set-up for measurement of the LED light source

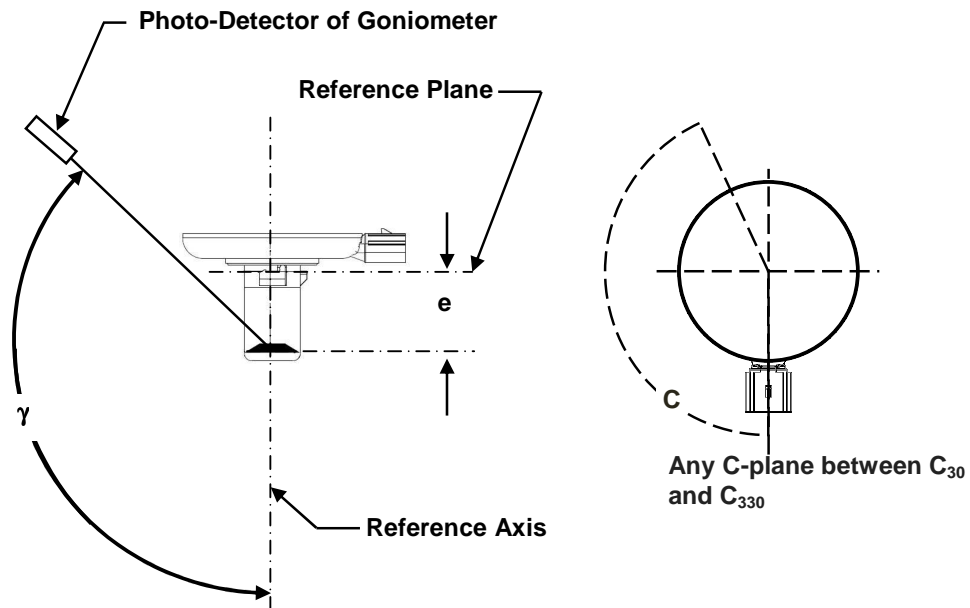

Figure 4 – Set-up to measure the luminous intensity distribution

Luminous intensity data is recorded for the major function with a standard photogoniometer. The measurement distance should be chosen appropriately, to make sure that the detector is located in the far field of the light distribution.

The measurements shall be performed in 3 C-planes, which contain the reference axis of the light source. The 3 C-planes shall be within  $C_{30}$  and  $C_{330}$  to avoid the connector shadows and they have to be at least  $30^\circ$  apart from each other. The test points for each plane for multiple polar angles  $\gamma$  are specified in Table 3.

After measurement the data shall be normalized to 1000lm according to Paragraph 3.1.11 using the luminous flux of the individual light source under test. The data shall comply with the tolerance band as defined in Table 3.

C-planes: see CIE publication 70-1987, "The measurement of absolute intensity distributions".

$\gamma$	LED light source of normal production		Standard LED light source	
	Minimum Intensity in cd /1000lm	Maximum Intensity in cd/1000lm	Minimum Intensity in cd /1000lm	Maximum Intensity in cd/1000lm
0°	0	30	0	20
15°	0	30	0	20
30°	0	70	0	40
45°	20	100	20	60
60°	35	120	35	80
75°	50	140	50	100
90°	70	160	70	120
105°	90	180	90	140
120°	110	200	110	160
135°	110	200	110	160
150°	90	180	90	140

**Table 3 – Test point values of normalized intensity for the major function of normal production and standard light sources, respectively.**

**The luminous intensity distribution as described in Table 3 shall be substantially uniform, i.e. in between two adjacent grid points the relative luminous intensity requirement is calculated by linear interpolation using the two adjacent grid points.**

Annex 2

COMMUNICATION

(maximum format : A4 (210 x 297 mm))

issued by: Name of administration

.....  
.....  
.....

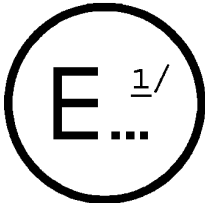

- concerning: 2/
- APPROVAL GRANTED
  - APPROVAL EXTENDED
  - APPROVAL REFUSED
  - APPROVAL WITHDRAWN
  - PRODUCTION DEFINITELY DISCONTINUED

of a type of LED light source pursuant to Regulation No. [xxx]

Approval No. ....

Extension No. ....

1. Trade name or mark of the device:.....
2. Manufacturer's name for the type of device:.....
3. Manufacturer's name and address: .....
4. If applicable, name and address of manufacturer's representative: .....  
.....
5. Submitted for approval on: .....
6. Technical service responsible for conducting approval tests:.....  
.....
7. Date of report issued by that service: .....
8. Number of report issued by that service:.....

- 9. Concise description: .....
- Category of **LED** light source: .....
- Rated voltage: .....
- Colour(s) of the light emitted: White/amber/red 2/
- 10. Position of the approval mark: .....
- 11. Reason(s) for extension (if applicable): .....
- 12. Approval granted/refused/extended/withdrawn: 2/
- 13. Place: .....
- 14. Date: .....
- 15. Signature: .....
- 16. The following documents, bearing the approval mark shown above, are available on request: .....

---

1/ Distinguishing number of the country which has granted/extended/refused/withdrawn approval (see approval provisions in the Regulation).

2/ Strike out what does not apply.

Annex 3

EXAMPLE OF THE ARRANGEMENT OF THE APPROVAL MARK

(see paragraph 2.4.4.)

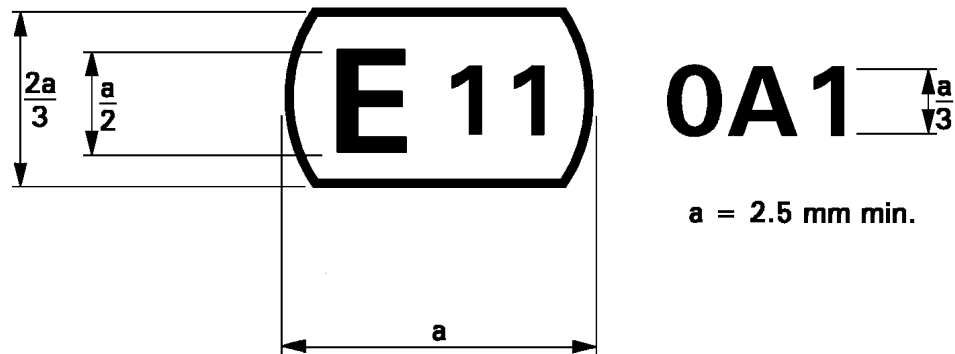

The above approval mark affixed to a **LED** light source indicates that the light source has been approved in the United Kingdom (E11) under the approval code 0A1. The first character of the approval code indicates that the approval was granted in accordance with the requirements of Regulation No. [xx] in its original form.

---

\*/ Not requiring changes in the approval number.

Annex 4

METHOD OF MEASUREMENT OF ELECTRICAL AND PHOTOMETRICAL  
CHARACTERISTICS

**Light sources of all categories with integrated heatsink shall be measured at ambient temperature of  $(23 \pm 2)^\circ\text{C}$  in still air. For these measurements the minimum free space as defined in the data sheets shall be maintained.**

**Light sources of all categories with definition of a temperature  $T_b$  shall be measured by stabilising the  $T_b$ -point at the specific temperature defined on the category data sheet.**

**1. Luminous flux**

**1.1. A luminous flux measurement using an integrating method shall be made**  
a) in case of an integrated heatsink after 1 minute and after 30 minutes of operation or  
b) after stabilisation of the temperature at the  $T_b$  point.

**1.2. The luminous flux values, as measured after**  
a) 30 minutes, or  
b) stabilisation of temperature  $T_b$   
shall comply with the minimum and maximum requirements.  
In case of a) this value shall be in between 100 per cent and 80 per cent of the value measured after 1 minute.

**1.3. Measurements have to be carried out at relevant test voltage and at the minimum and maximum values of the relevant voltage range. Unless specified more tightly on the data sheet the following deviation of the luminous flux at the tolerance interval limits shall not be exceeded.**

Rated voltage	Min voltage	Max voltage
6	6.0	7.0
12	12.0	14.0
24	24.0	28.0
Corresponding luminous flux tolerance*	$\pm 30\%$	$\pm 15\%$

\* The maximum luminous flux deviation at the tolerance limits is calculated by using the measured flux at test voltage as reference. In between test voltage and voltage range limits the luminous flux behaviour shall be substantially uniform.

**2. Normalized luminous intensity**

**2.1. The luminous intensity measurements shall be started after**  
a) 30 minutes of stabilization time or

- b) stabilisation of temperature  $T_b$  at the value given in the relevant data sheet.**
- 2.2. Measurements have to be carried out at relevant test voltage.**
- 2.3 Normalized luminous intensity of a test sample is calculated by dividing the luminous intensity distribution as measured under 2.1 by the luminous flux as determined after 30 minutes under 1.2.**
- 3. Colour**
- The colour of the light emitted as measured under the same conditions as described in 1.1. shall both be within the required colour boundaries.**
- 4. Power consumption**
- 4.1 A power consumption measurement shall be made under the same conditions as described in 1.1 using the requirements of paragraph 3.3.3.**
- 4.2 Power consumption measurements shall be carried out at relevant test voltage.**
- 4.3 Values obtained shall comply with the minimum and maximum requirements of the relevant data sheet.**

Annex 5

MINIMUM REQUIREMENTS FOR QUALITY CONTROL PROCEDURES  
BY THE MANUFACTURER

1. General

The conformity requirements shall be considered satisfied from a photometric, geometrical, visual and electrical standpoint if the specified tolerances for production **LED** light sources in the relevant data sheet of Annex 1 and the relevant data sheet for the caps are met.

2. Minimum requirements for verification of conformity by the manufacturer

For each type of **LED** light source the manufacturer or the holder of the approval mark shall carry out tests, in accordance with the provisions of this Regulation, at appropriate intervals.

2.1. Nature of tests

Tests of conformity of these specifications shall cover their photometric, geometrical and optical characteristics.

2.2. Methods used in tests

2.2.1. Tests shall generally be carried out in accordance with the methods set out in this Regulation.

2.2.2. The application of paragraph 2.2.1. requires regular calibration of test apparatus and its correlation with measurements made by a competent authority.

2.3. Nature of sampling

Samples of **LED** light sources shall be selected at random from the production of a uniform batch. A uniform batch means a set of **LED** light sources of the same type, defined according to the production methods of the manufacturer.

2.4. Inspected and recorded characteristics

The **LED** light sources shall be inspected and test results recorded following the grouping of characteristics as listed in **Annex 6**, Table 1.



2.5. Criteria governing acceptability

The manufacturer or the holder of approval is responsible for carrying out a statistical study of the test results in order to meet the specifications laid down for verification of conformity of production in paragraph 4.1. of this Regulation.

Compliance shall be assured if the level of acceptable non-compliance per grouping of characteristics given in Table 1 of **Annex 6** is not exceeded. This means that the number of **LED** light sources not complying with the requirement for any grouping of characteristics of any **LED** light sources type does not exceed the qualifying limits in the relevant Tables 2, 3 or 4 of **Annex 6**.

Note: Each individual **LED** light source requirement shall be considered as a characteristic.

Annex 6

## SAMPLING AND COMPLIANCE LEVELS FOR MANUFACTURER TEST RECORDS

Table 1 - Characteristics

Grouping of characteristics	Grouping */ of test records between lamp types	Minimum 12 monthly sample per grouping */	Acceptable level of non-compliance per grouping of characteristics (%)
Marking, legibility and durability	All types with the same external dimensions	<b>315</b>	<b>1</b>
External lamp dimensions (excluding cap/base)	All types of the same category	<b>200</b>	<b>1</b>
Dimensions of caps and bases	All types of the same category	<b>200</b>	<b>6.5</b>
Dimensions related to light emitting surface and internal elements **/	All lamps of one type	<b>200</b>	<b>6.5</b>
Initial readings, power, colour and luminous flux **/	All lamps of one type	<b>200</b>	<b>1</b>
Normalised luminous intensity distribution	All lamps of one type	<b>20</b>	<b>6.5</b>

\*/ The assessment shall in general cover series production **LED** light sources from individual factories. A manufacturer may group together records concerning the same type from several factories, provided these operate under the same quality system and quality management.

\*\*/ In case a **LED** light source has more than one light output function the grouping of characteristics (dimensions, power, colour and luminous flux) applies to each element separately.

Qualifying limits for acceptance based on different numbers of test results for each grouping of characteristics are listed in Table 2 as maximum number of non-compliance. The limits are based on an acceptable level of 1 per cent of non-compliance, assuming an acceptance probability of at least 0.95.

Table 2

Number of test results of each characteristics	Qualifying limits for acceptance
20	0
21 - 50	1
51 - 80	2
81 - 125	3
126 - 200	5
201 - 260	6
261 - 315	7
316 - 370	8
371 - 435	9
436 - 500	10
501 - 570	11
571 - 645	12
646 - 720	13
721 - 800	14
801 - 860	15
861 - 920	16
921 - 990	17
991 - 1,060	18
1,061 - 1,125	19
1,126 - 1,190	20
1,191 - 1,249	21

Qualifying limits for acceptance based on different numbers of test results for each grouping of characteristics are listed in Table 3 given as maximum number of non-compliance. The limits are based on an acceptable level of 6.5 per cent of non-compliance, assuming an acceptance probability of at least 0.95.

Table 3

Number of lamps in records	Qualifying limit	Number of lamps in records	Qualifying limit	Number of lamps in records	Qualifying limit
20	3	500 - 512	44	881 - 893	72
21 - 32	5	513 - 526	45	894 - 907	73
33 - 50	7	527 - 540	46	908 - 920	74
51 - 80	10	541 - 553	47	921 - 934	75
81 - 125	14	554 - 567	48	935 - 948	76
126 - 200	21	568 - 580	49	949 - 961	77
201 - 213	22	581 - 594	50	962 - 975	78
214 - 227	23	595 - 608	51	976 - 988	79
228 - 240	24	609 - 621	52	989 - 1,002	80
241 - 254	25	622 - 635	53	1,003 - 1,016	81
255 - 268	26	636 - 648	54	1,017 - 1,029	82
269 - 281	27	649 - 662	55	1,030 - 1,043	83
282 - 295	28	663 - 676	56	1,044 - 1,056	84
296 - 308	29	677 - 689	57	1,057 - 1,070	85
309 - 322	30	690 - 703	58	1,071 - 1,084	86
323 - 336	31	704 - 716	59	1,085 - 1,097	87
337 - 349	32	717 - 730	60	1,098 - 1,111	88
350 - 363	33	731 - 744	61	1,112 - 1,124	89
364 - 376	34	745 - 757	62	1,125 - 1,138	90
377 - 390	35	758 - 771	63	1,139 - 1,152	91
391 - 404	36	772 - 784	64	1,153 - 1,165	92
405 - 417	37	785 - 798	65	1,166 - 1,179	93
418 - 431	38	799 - 812	66	1,180 - 1,192	94
432 - 444	39	813 - 825	67	1,193 - 1,206	95
445 - 458	40	826 - 839	68	1,207 - 1,220	96
459 - 472	41	840 - 852	69	1,221 - 1,233	97
473 - 485	42	853 - 866	70	1,234 - 1,249	98
486 - 499	43	867 - 880	71		

Qualifying limits for acceptance based on different numbers of test results for each grouping of characteristics are listed in Table 4 given as a percentage of the results, assuming an acceptance probability of at least 0.95.

Table 4

Number of test results of each characteristic	Qualifying limits shown as a percentage of results. Acceptable level of 1% of non-compliance	Qualifying limits shown as a percentage of results. Acceptable level of 6.5% of non-compliance
1,250	1.68	7.91
2,000	1.52	7.61
4,000	1.37	7.29
6,000	1.30	7.15
8,000	1.26	7.06
10,000	1.23	7.00
20,000	1.16	6.85
40,000	1.12	6.75
80,000	1.09	6.68
100,000	1.08	6.65
1,000,000	1.02	6.55

Annex 7

MINIMUM REQUIREMENTS FOR SPOT CHECKS  
BY THE ADMINISTRATIVE AUTHORITY

1. General

The conformity requirements shall be considered satisfied from a photometric, geometrical, visual and electrical standpoint if the specified tolerances for production **LED** light sources in the relevant data sheet of Annex 1 and the relevant data sheet for the caps are met.

2. The conformity of mass-produced **LED** light sources shall not be contested if the results are in agreement with Annex 8 to this Regulation.
3. Conformity shall be contested and the manufacturer requested to make the production meet the requirements if the results are not in agreement with **Annex 8** to this Regulation.
4. If paragraph 3 of this annex is applied, a further sample of 250 **LED** light sources, selected at random from a recent production run, shall be taken within two months.

Annex 8

COMPLIANCE APPROVED BY SPOT CHECK

Compliance approved or disapproved shall be decided according to the values in Table 1. For each grouping of characteristics **LED** light sources shall be either accepted or rejected according to the values in Table 1 \*/.

Table 1

	1 % <u>**/</u>		6.5 % <u>**/</u>	
	Accept	Reject	Accept	Reject
First sample size: 125	2	5	11	16
If the number of non-conforming units is greater than 2 (11) and less than 5 (16) take a second sample size of 125 and assess the 250	6	7	26	27

\*/ The proposed scheme is designed to assess the compliance of **LED** light sources to an acceptance level of non-compliance of 1 per cent and 6.5 per cent respectively and is based on the Double Sampling Plan for Normal Inspection in IEC Publication 60410: Sampling Plans and Procedures for Inspection by Attributes.

\*\*/ The **LED** light sources shall be inspected and test results recorded following the grouping of characteristics as listed in Annex 6, Table 1.

## B. JUSTIFICATION

LED light sources as non-replaceable light sources in signalling devices, or as part of light source modules of signalling devices, have been included in the regulations for some years and are widely installed on vehicles. Recently LED modules for forward lighting applications have been introduced into the regulations. In the meantime, coloured LED light source technologies, in particular for the red colour, are becoming mature.

A new draft regulation for LED light sources for use in signalling devices is proposed. It is intended to provide an additional light source option of replaceable approved LED light sources.

Categories for LED light sources are specified in a similar way as in Regulation No. 37 for filament light sources and Regulation No. 99 for gas discharge light sources. Conventionally, for filament lamps, the position and dimensions of the filament and, for gas discharge light sources, the position and form of the luminous arc are specified as the emitting surface. In the case of LED light sources, a luminous intensity distribution and the position and dimensions of the emitting surface are specified. LED light sources are defined for the usual board net supply of 6V, 12V or 24V systems. The heat sink may be integrated. Thermal management may also be provided by external parts.

As a first category a dual function red LED light source LR1 is proposed. A similar light source has already been on the market in non-ECE countries or as a Light Source Module in ECE countries.

GTB is working on the specification of more categories and will propose such new categories at a later stage. In the meantime, GTB is confident that this proposal for approved LED light sources as an additional option will be widely appreciated.

-----