

Draft corrigendum to ECE/TRANS/WP.29/GRSP/2010/36

(REGURATION No.80 (Strength of seats and anchorages in buses))

Note: The modifications to the ECE/TRANS/WP.29/GRSP/2010/36 are marked in bold for new or strikethrough for deleted characters.

A. PROPOSAL

Paragraphs 7.4.2. and 7.4.3., shall be deleted

Appendix 7, Figure 1., amend to read

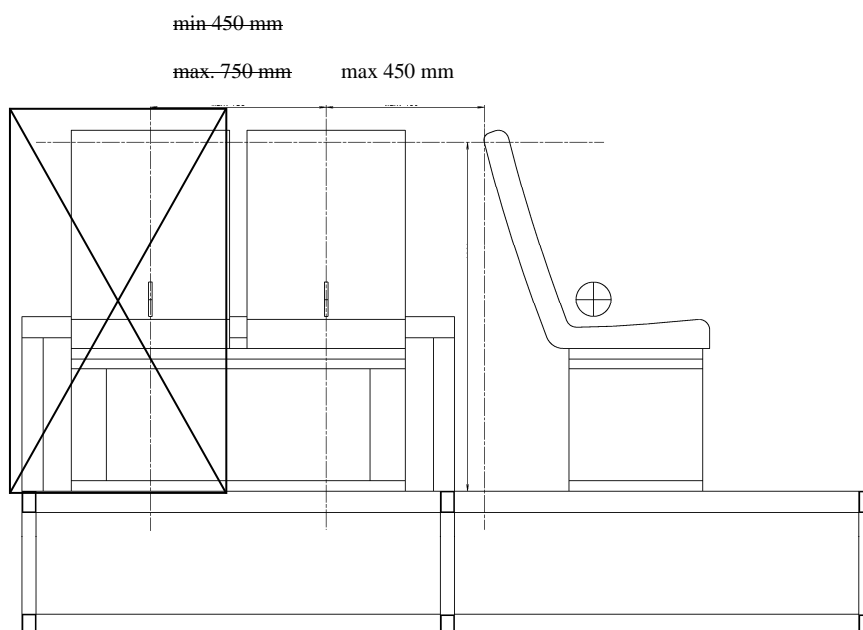

Figure 1: Positioning requirements for side-facing seats

B. JUSTIFICATION

During the test for the safeguarding of passengers in side-facing seats (Appendix 7), it is not necessary to describe two seats on Figure 1 in Appendix 7, as the dummy is only positioned on the side-facing-seat behind the front-seat (test seat).