

B. TEXT OF THE REGULATION

1. PURPOSE

This regulation specifies requirements for head restraints to reduce the frequency and severity of injuries caused by **relative motion among the head, the neck, and the torso.**

2. APPLICATION / SCOPE

This regulation applies to all Category 1-1 vehicles; Category 1-2 vehicles with a Gross Vehicle Mass of up to 4,500 kg; and Category 2 vehicles with a Gross Vehicle Mass of up to 4,500 kg. 1/

3. DEFINITIONS

- 3.1. "Adjustable head restraint" means a head restraint that is capable of movement independent of the seatback between at least two positions of adjustment intended for occupant use.
- 3.2. "Backlight" means rearward-facing window glazing located at the rear of the roof panel.
- 3.3. "Backset" means the horizontal distance between the front surface of the head restraint and the rearmost point of the head restraint measurement device, as measured in accordance with Annex 4 or Annex 5.
- 3.4. "Head restraint" means, at any designated seating position, a device that limits rearward displacement of a seated occupant's head relative to the occupant's torso and that has a height equal to or greater than 700 mm at any point between two vertical longitudinal planes passing at 85 mm on either side of the torso line, in any position of backset and height adjustment, as measured in accordance with Annex 1.

1/ A contracting party may restrict application of the requirements in its domestic legislation if it decides that such restriction is appropriate.

- 3.5. "Head restraint measurement device (HRMD)" means a separate head shaped device used with the H-point machine with the head form, as defined in Annex 4, attached with sliding scale at the back of the head for the purpose of measuring backset. 2/
- 3.6. "Three-dimensional H-point machine" (H-point machine) means the device used for the determination of "H-points" and actual torso angles. This device is defined in Annex 13.
- 3.7. "Head restraint height" means the distance from the R-point, measured parallel to the torso line to the top of the head restraint on a plane normal to the torso line.
- 3.8. "Intended for occupant use" means, when used in reference to the adjustment of a seat and head restraint, adjustment positions used by seated occupants while the vehicle is in motion, and not those intended solely for the purpose of allowing ease of ingress and egress of occupants; access to cargo storage areas; and storage of cargo in the vehicle.
- 3.9. "H-point" means the pivot centre of the torso and thigh of the H-point machine when installed in a vehicle seat in accordance with Annex 12. Once determined in accordance with the procedure described in Annex 12, the "H" point is considered fixed in relation to the seat-cushion structure and is considered to move with it when the seat is adjusted.
- ["Longitudinal plane" means a plane parallel to the median longitudinal plane of the vehicle.]**
- 3.10. "R-point" means a design point defined by the vehicle manufacturer for each designated seating position and established with respect to the three-dimensional reference system as defined by Annex 11. The R-point:
- 3.10.1. Establishes the rearmost normal design driving or riding position of each designated seating position in a vehicle;
- 3.10.2. Has coordinates established relative to the designed vehicle structure;
- 3.10.3. Simulates the position of the centre pivot of the human torso and thigh;
- 3.10.4. Is defined in Annex 12 of this regulation.

2/ The technical specifications and detailed drawings of HRMD, are deposited with the Secretary General of the United Nations and may be consulted on request at the secretariat of the UNECE, Palais des Nations, Geneva, Switzerland.

- 3.11. "Top of the head restraint" means the point on the head restraint centreline with the greatest height.
- 3.12. "Torso line" means the centreline of the probe of the H-point machine with the probe in the fully rearward position.
- 3.13. "Actual torso angle" means the angle measured between a vertical line through the H-point and the torso line using the back angle quadrant on the H-point machine. The actual torso angle corresponds theoretically to the design torso angle.
- 3.14. "Design torso angle" means the angle measured between a vertical line through the R-point and the torso line in a position which corresponds to the design position of the seat back established by the vehicle manufacturer.

4. GENERAL REQUIREMENTS

- 4.1. Whenever a range of measurements is specified, the head restraint shall meet the requirement at any position of adjustment intended for occupant use.
- 4.2. In each vehicle subject to the requirements of this regulation, a head restraint shall be provided at each front outboard designated seating position, conforming to either paragraph 4.2.1. or paragraph 4.2.2.
- 4.2.1. The head restraint shall conform to paragraphs 5.1., 5.2., 5.4., and 5.5. of this regulation.
- 4.2.2. The head restraint shall conform to paragraphs 5.1.1. through 5.1.4., 5.3., 5.4., and 5.5. of this regulation.
- 4.3. For vehicles equipped with rear outboard and/or front centre head restraints, the head restraint shall conform to either paragraph 4.3.1. or paragraph 4.3.2.
- 4.3.1. The head restraint shall conform to paragraphs 5.1.1. through 5.1.4., 5.2., 5.4., and 5.5. of this regulation.
- 4.3.2. The head restraint shall conform to paragraphs 5.1.1. through 5.1.4., 5.3., 5.4., and 5.5. of this regulation.
- 4.4. For vehicles equipped with rear centre head restraints, the head restraint shall conform to either paragraph 4.4.1 or 4.4.2.
- 4.4.1. The head restraint shall conform to paragraphs 5.1.2. through 5.1.4., 5.2., 5.4., and 5.5. of this regulation.

- 4.4.2. The head restraint shall conform to paragraphs 5.1.2. through 5.1.4., 5.3., 5.4., and 5.5. of this regulation.
- 4.5. This regulation does not apply to auxiliary seats such as temporary or folding jump seats or to side-facing or rear-facing seats.
- 4.6. At designated seating positions incapable of seating the test dummy specified in paragraph 5.3. of this regulation, the applicable head restraint shall conform to either paragraph 4.2.1., or 4.3.1, or 4.4.1. of this regulation, as appropriate.

5. PERFORMANCE REQUIREMENTS

5.1. Dimensional requirements

5.1.1. Minimum Height

5.1.1.1. General specifications

The following requirements on minimum height shall be demonstrated in accordance with Annex 1.

5.1.1.2. Front outboard designated seating positions

**[The top of a head restraint located in a front outboard designated seating position shall, except as provided in paragraph 5.1.1.4. of this regulation, have a height of:
(a) not less than 800 mm in at least one position of head restraint] adjustment, and
(b) not less than 750 mm in any position of head restraint adjustment.]**

5.1.1.3. Front centre designated seating positions equipped with head restraints

The top of a head restraint located in the front centre designated seating position shall have a height of not less than 750 mm in any position of adjustment, except as provided in paragraph 5.1.1.4. of this regulation.

5.1.1.4. Exception

[The top of a head restraint located in a front outboard designated seating position shall have a height of not less than 700 mm when the head restraint is adjusted to its lowest position intended for occupant use; if the interior surface of the vehicle roofline, including the headliner, physically prevents a head restraint, located in the front designated seating position, from attaining the height required by paragraphs 5.1.1.2. and 5.1.1.3. of this regulation. In those instances,

the vertical distance between the top of the head restraint and the interior surface of the roofline, including the headliner, shall not exceed 50 mm for convertibles and 25 mm for all other vehicles, when the head restraint is adjusted to its highest position intended for occupant use.]

5.1.1.5. Rear outboard designated seating positions equipped with head restraints

The top of a head restraint located in a rear outboard designated seating position shall have a height of not less than 750 mm in any position of adjustment, except as provided in paragraph 5.1.1.6. of this regulation,

5.1.1.6. Exception

The requirements of paragraph 5.1.1.5. of this regulation do not apply if the interior surface of the vehicle roofline, including the headliner, or backlight physically prevent a head restraint, located in the rear outboard designated seating position, from attaining the required height. In those instances, the maximum vertical distance between the top of the head restraint and interior surface of the roofline, including the headliner, or the backlight shall not exceed 50 mm for convertibles and 25 mm for all other vehicles, when the head restraint is adjusted to its highest position intended for occupant use.

5.1.2. Minimum width

When measured in accordance with Annex 2, the lateral width of a head restraint shall be not less than 85 mm on either side of the torso line (distances L and L' measured as per Annex 2).

5.1.3. Gaps within head restraint

If a head restraint has any gap greater than 60 mm when measured in accordance with Annex 3, the maximum rearward displacement of the head form shall be less than 102 mm when the head restraint is tested at that gap in accordance with Annex 6.

5.1.4. Gaps between head restraint and the top of the seat back

When measured in accordance with Annex 3, there shall not be a gap greater than 60 mm between the bottom of the head restraint and the top of the seat back if the head restraint can not be adjusted in height.

In the case of head restraints adjustable in height to more than one position intended for occupant use, when measured in accordance with Annex 3, there shall not be a gap greater than 25 mm between the bottom of the head restraint and the top of the seat back, with the head restraint adjusted

to its lowest height position.

5.1.5. Backset requirements

5.1.5.1. General specifications

5.1.5.1.1. Head restraints on the front outboard designated seating positions shall meet the backset requirements of paragraph 5.1.5.2.

5.1.5.2. Static maximum backset requirements

5.1.5.2.1. For height adjustable head restraints, the requirements shall be met with the top of the head restraint in all height positions of adjustment between 750 mm and 800 mm, inclusive. If the top of the head restraint, in its lowest position of adjustment, is above 800 mm, the requirements of this regulation shall be met at that position only.

5.1.5.2.2. When measured in accordance with Annex 4, the backset shall not be more than 55 mm. Based on a determination by each Contracting Party or regional economic integration organization, the manufacturer may be allowed the option to measure in accordance with Annex 5 as an alternative, in which case the backset shall not be more than 45 mm.

5.1.5.2.3. In the case of Annex 4, if the front outboard head restraint is not attached to the seat back, it shall not be possible to adjust the head restraint such that the backset is more than 55 mm when the seat back inclination is positioned closer to vertical than the position specified in Annex 4.

5.1.5.2.4. The above requirements on maximum backset shall be demonstrated by taking the arithmetic mean of 3 measurements obtained in accordance with Annex 4 or Annex 5.

5.2. Static performance requirements

Each head restraint shall conform to paragraphs 5.2.1. through 5.2.4. of this regulation.

5.2.1. Energy absorption

When the front surface of the head restraint is impacted in accordance with Annex 7, the deceleration of the head form shall not exceed 785 m/s^2 (80g) continuously for more than 3 milliseconds.

5.2.2. Adjustable head restraint height retention

When tested in accordance with Annex 8, the mechanism of the adjustable head restraint shall not fail in such a way as to allow downward movement

of the head restraint by more than 25 mm.

5.2.3. Displacement and backset retention

5.2.3.1. General Specifications.

5.2.3.1.1. In the case of head restraints with an adjustable backset, the head restraint shall conform to the displacement and backset retention requirements of paragraph 5.2.3.2. of this regulation. However, based on the determination of each Contracting Party or regional economic integration organization, the manufacturer may be allowed to apply the displacement requirements of paragraph 5.2.3.3. as an alternative.

5.2.3.1.2. All other head restraints shall conform to the displacement requirements of paragraph 5.2.3.3.

5.2.3.2. Displacement and backset retention.

5.2.3.2.1. When the head restraint is tested in any position of backset adjustment in accordance with Annex 6, the head form shall:

5.2.3.2.1.1. Not be displaced more than 25 mm during the application of the initial reference moment of 37 Nm;

5.2.3.2.1.2. Not be displaced more than 102 mm perpendicularly and rearward of the displaced extended torso line during the application of a 373 Nm moment about the R-point; and

5.2.3.2.1.3. Return to within 13 mm of its initial reference position after the following sequence occurs: application of a 373 Nm moment about the R-point; reduction of the moment to 0 Nm; and by re-application of the initial reference load 37 Nm.

5.2.3.3. Displacement

5.2.3.3.1. When the head restraint is tested in the rearmost (relative to the seat) position of horizontal adjustment (if provided) in accordance with Annex 6, the head form shall not be displaced more than 102 mm perpendicularly and rearward of the displaced extended torso line during the application of a 373 Nm moment about the R-point.

5.2.4. Head restraint strength

When the head restraint is tested in accordance with Annex 6, the load applied to the head restraint shall reach 890 N and remain at 890 N for a period of 5 seconds.

5.3. Dynamic performance requirements

- 5.3.1. ~~Based on a determination by each Contracting Party or regional economic integration organization, either a Hybrid III 50th percentile male dummy 3/ or a BioRID II 50th percentile male dummy shall be used to determine compliance. If a Hybrid III dummy is used, the head restraint shall meet the requirements of paragraph 5.3.2. If a BioRID II dummy is used, the head restraint shall meet the requirements of paragraph 5.3.3.~~

[A BioRID II 50th percentile male dummy 3/ shall be used to determine compliance. The head restraint shall meet the requirements of paragraph 5.3.2.]

5.3.2. Hybrid III Requirements

[BioRID II Requirements]

- 5.3.2.1. ~~When tested during forward acceleration of the dynamic test platform, in accordance with Annex 9, at each designated seating position equipped with a head restraint, the head restraint shall conform to paragraphs 5.3.2.2 and 5.3.2.3.~~

[Each head restraint, when tested during forward acceleration or deceleration of the dynamic test platform, using BioRID II 50th percentile male dummy 3/ in accordance with Annex 9, shall conform to the requirements of paragraph 5.3.2.2.]

5.3.2.2. ~~Angular rotation~~

~~Limit the maximum rearward angular rotation between the head and torso of the 50th percentile male Hybrid III test dummy to 12 degrees for the dummy in all outboard designated seating positions;~~

3/ ~~The technical specifications and detailed drawings of Hybrid III dummy, corresponding to the principal dimensions of a 50th percentile male of the United States of America, and the specifications for its adjustment for this test are deposited with the Secretary General of the United Nations and may be consulted on request at the secretariat of the UNECE, Palais des Nations, Geneva, Switzerland.~~

[The technical specifications and detailed drawings of BioRID II dummy, corresponding to the principal dimensions of a 50th percentile male of the United States of America, and the specifications for its adjustment for this test are deposited with the Secretary General of the United Nations and may be consulted on request at the secretariat of the UNECE, Palais des Nations, Geneva, Switzerland.]

~~5.3.2.3. Head injury criteria~~

~~Limit the maximum HIC15 value to 500. HIC15 is calculated as follows: For any two points in time, t_1 and t_2 , during the event which are separated by not more than a 15 millisecond time interval and where t_1 is less than t_2 , the head injury criterion (HIC15) is determined using the resultant head acceleration at the centre of gravity of the dummy head, a_r , expressed as a multiple of g (the acceleration of gravity) and is calculated using the expression:-~~

$$\text{HIC} = \left[\frac{1}{(t_2 - t_1)} \int_{t_1}^{t_2} a_r dt \right]^{2.5} (t_2 - t_1)$$

[5.3.2.2 Evaluation Criteria

Each head restraint shall meet the requirements of paragraphs 5.3.2.2.1 and 5.3.2.2.2 using the dummy.

5.3.2.2.1. Neck Injury Criterion (NIC)

NICmax shall not exceed [23.4].

5.3.2.2.2 Neck force and moment

Upper neck shear force (Upper Neck Fx), flexion and extension: FXmax shall not exceed [61.3].

Lower neck shear force (Lower Neck Fx), flexion and extension: FXmax shall not exceed [61.3].

Upper neck axial force (Upper Neck Fz): Fzmax shall not exceed [933.5].

Lower neck axial force (Lower Neck Fz): Fzmax shall not exceed [1113.1].

Upper neck lateral axial rotation moment (Upper Neck My): My^{oc}max shall not exceed [31.6].

Lower neck lateral axial rotation moment (Lower Neck My): Mymax shall not exceed [31.6].

~~5.3.3. BioRID II Requirements~~

~~Reserved: Until BioRID II requirements are included in this regulation or adopted in the national regulation of a Contracting Party or regional economic integration organization, head restraints shall comply with either~~

~~paragraph 5.3.3.1. or 5.3.3.2. as appropriate.~~

~~5.3.3.1. Based on a determination by each Contracting Party or regional economic integration organization, dynamic head restraints shall comply with any or all of the items contained in paragraph 5.2.~~

~~5.3.3.2. All other head restraints shall meet the requirements of either paragraph 4.2.1, 4.3.1, or 4.4.1, as appropriate.~~

5.4. Non-use positions

5.4.1. A driver head restraint shall not have a non-use position.

5.4.2. A front outboard passenger head restraint may be adjusted to a position at which its height does not comply with the requirements of paragraph 5.1.1.2. of this regulation. However, in any such position, the front outboard passenger head restraint shall meet paragraph 5.4.4.1. of this regulation.

5.4.3. All rear head restraints and any front centre head restraint may be adjusted to a position at which their height does not comply with the requirements of either paragraph 5.1.1.3. or 5.1.1.5. of this regulation. However, in any such position, the head restraint shall also meet one additional requirement from a set of several alternative test requirements.

The set of alternative test requirements may be, at the choice of the manufacturer either paragraph 5.4.4.1., or 5.4.4.2., or 5.4.4.3. or 5.4.4.4. of this regulation.

Based on a determination by each Contracting Party or regional economic integration organization, the manufacturer may also be allowed to choose paragraph 5.4.4.5. of this regulation as an alternative to paragraphs 5.4.4.1. through 5.4.4.4.

5.4.4. Alternative requirements

All of the items described in paragraphs 5.4.4.1. through 5.4.4.5. are permitted as additional features.

5.4.4.1. In all designated seating positions equipped with head restraints, except the driver's designated seating position, the head restraint shall automatically return from a non-use position to a position in which its minimum height is not less than that specified in paragraph 5.1.1. of this regulation when a 5th percentile female Hybrid III test dummy ^{4/} is positioned in the seat in accordance with Annex 10. At the option of the

manufacturer, instead of using a 5th percentile female Hybrid III test dummy, human beings may be used as specified in Annex 10.

4/ The technical specifications and detailed drawings of Hybrid III dummy, corresponding to the principal dimensions of a 5th percentile female of the United States of America, and the specifications for its adjustment for this test are deposited with the Secretary General of the United Nations and may be consulted on request at the secretariat of the UNECE, Palais des Nations, Geneva, Switzerland.

- 5.4.4.2. In front centre and rear designated seating positions equipped with head restraints, the head restraint shall, when tested in accordance with Annex 10, be capable of manually rotating either forward or rearward by not less than 60 degrees from any position of adjustment intended for occupant use in which its minimum height is not less than that specified in paragraph 5.1.1. of this regulation.
- 5.4.4.3. When measured in accordance with Annex 10, the lower edge of the head restraint (HLE) shall be not more than 460 mm, but not less than 250 mm from the R-point and the thickness (S) shall not be less than 40 mm.
- 5.4.4.4. When tested in accordance with Annex 10, the head restraint shall cause the torso line angle to be at least 10 degrees closer to vertical than when the head restraint is in any position of adjustment in which its height is not less than that specified in paragraph 5.1.1. of this regulation.
- 5.4.4.5. The head restraint shall be marked with a label in the form of a pictogram which may include explanatory text. The label shall either provide an indication when the head restraint is in a non-use position or provide information to enable an occupant to determine whether the head restraint is in a non-use position. The label shall be durably affixed and located such that it is clearly visible by an occupant when entering the vehicle to the designated seating position. Examples of possible designs of pictograms are shown in Figure 1.

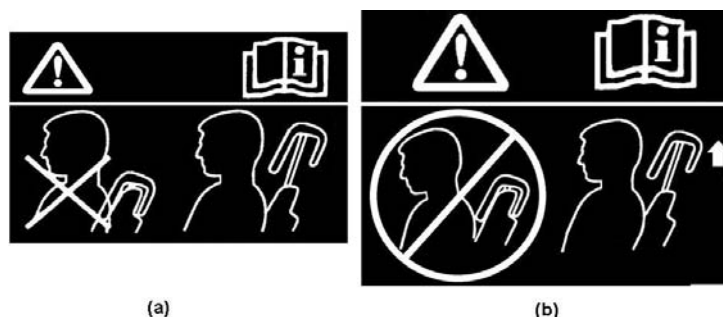

Figure 1

5.5. Removability of head restraints

The head restraints shall not be removable without a deliberate action distinct from any action necessary for upward head restraint adjustment.

6. TEST CONDITIONS

The test procedures described in the following annexes are to be performed using any or all of the following:

- 6.1. A full vehicle including at least the seat to be tested and all necessary seat and head restraint equipment.
- 6.2. A vehicle body in white including at least the seat to be tested and all necessary seat and head restraint equipment.
- 6.3. ~~A seat equipped with its head restraint and all necessary attachment hardware, as well as all necessary equipment for the activation of dynamic head restraints.—~~

[A seat equipped with its head restraint and all necessary attachment hardware, as well as all necessary equipment for the activation of dynamic head restraint which is triggered externally to the seat. Where manufacturer requests, a seat belt, equivalent of that used in the vehicle, and its anchorages may be used.]

When additional support is provided by the vehicle body structures, a vehicle body in white including at least the seat to be tested and all necessary seat and head restraint equipment, as well as all necessary equipment for the activation of dynamic head restraint which is triggered externally to the seat.]

Annex 1

MINIMUM HEIGHT MEASUREMENT TEST PROCEDURE

[1. PURPOSE

The purpose of this test procedure is to demonstrate compliance with the minimum height requirements described in paragraph 5.1.1. of this regulation.

2. PROCEDURE FOR HEIGHT MEASUREMENT

Compliance with the requirements of paragraph 5.1.1. of this regulation is demonstrated by using the height measurement apparatus defined in paragraph 2.2. below.

The seat is adjusted such that its H-point coincides with the R- point; if the seat back is adjustable, it is set at the design seat back angle; both of these adjustments are in accordance with the requirements of paragraph 2.1. below. The height of the head restraint is the distance between point A and the intersection of lines AE and FG.

2.1. Relationship between the H-point and the R-point

When the seat is positioned in accordance to the manufacturer's specifications, the H-point, as defined by its coordinates, shall lie within a square of 50 mm side length with horizontal and vertical sides whose diagonals intersect at the R-point, and the actual torso angle is within 5 degrees of the design torso angle.

2.1.1. If these conditions are met, the R-point and the design torso angle are used to determine the height of the head restraints in accordance with this Annex.

2.1.2. If the H-point or the actual torso angle does not satisfy the requirements of paragraph 2.1., the H-point and the actual torso angle are determined twice more (three times in all). If the results of two of these three operations satisfy the requirements, the conditions of paragraph 2.1.1. shall apply.

2.1.3. If the results of at least two of the three operations described in paragraph 2.1.2. do not satisfy the requirements of paragraph 2.1. the centroid of the three measured points or the average of the three measured angles is used and be regarded as applicable in all cases where the R-point or the design torso angle is referred to in this Annex.

2.2. Height measuring apparatus

The height measurement apparatus consists of (see Figure 1-1):

2.2.1. A straight edge AE. The lower point A is placed at the R point location in accordance with paragraph 2.1. of this Annex. The line AE is parallel to the design torso angle.

2.2.2. A straight edge FG, perpendicular to the line AE and in contact with the top of the head restraint. The height of the head restraint is the distance between point A and the intersection of the lines AE and FG.

2.3. Height measurement for front outboard head restraints

2.3.1. If adjustable, adjust the top of the head restraint to the highest position and measure the height.

If adjustable, adjust the top of the head restraint to the lowest position intended for normal use, other than any non-use position described in paragraph 5.4. of this regulation, and measure the height.

2.3.2. For front outboard head restraints that are prevented by the interior surface of the vehicle roofline from meeting the required height as specified in paragraph 5.1.1.2. of this regulation, the requirements of paragraph 5.1.1.4. of this regulation are assessed by the following procedure:

2.3.2.1. Adjust the head restraint to its maximum height and measure the clearance between the top of the head restraint and the interior surface of the roofline or the rear backlight, by attempting to pass a 25 ± 0.5 mm sphere between them. In the case of convertibles, the diameter of the sphere is 50 ± 0.5 mm.

2.3.2.2. Adjust the top of the head restraint to the lowest position of adjustment intended for normal use, other than any non-use position described in paragraph 5.4. of this regulation, and measure the height.

2.4. Height measurement for front centre and rear outboard head restraints

2.4.1. If adjustable, adjust the top of the head restraint to the lowest position of adjustment intended for normal use, other than any non-use position described in paragraph 5.4. of this regulation and measure the height.

2.4.2. For head restraints that are prevented by the interior surface of the vehicle roofline or rear backlight from meeting the required height as

specified in paragraphs 5.1.1.3. or 5.1.1.5. of this regulation, the requirements of paragraphs 5.1.1.4. and 5.1.1.6. are assessed by the following procedure:

- 2.4.2.1. If adjustable, adjust the head restraint to its maximum height and measure the clearance between the top of the head restraint or the seat back at all seat back angles for intended use and the interior surface of the roofline or the rear backlight, by attempting to pass a 25 ± 0.5 mm sphere between them. In the case of convertibles, the diameter of the sphere is 50 ± 0.5 mm.

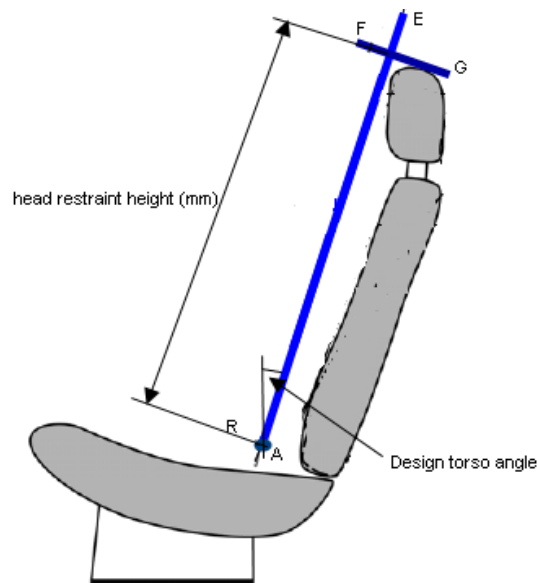

Figure 1-1]

Annex 2

MINIMUM WIDTH MEASUREMENT TEST PROCEDURE

1. PURPOSE

The purpose of this test procedure is to demonstrate compliance with the minimum width requirements described in paragraph 5.1.2. of this regulation.

2. PROCEDURE FOR WIDTH MEASUREMENT

2.1. The seat is adjusted such that its H-point coincides with the R-point; if the seat back is adjustable, it is set at the design seat back angle; both these adjustments are in accordance with the requirements of paragraph 2.1. of Annex 1.

2.2. The plane S1 is a plane perpendicular to the reference line and situated 65 ± 3 mm below the top of the head restraint.

2.3. Planes P and P' are vertical longitudinal planes, tangential to each side of the head restraint to be measured.

2.4. Measure the distance L and L', measured in the plane S1 between the vertical longitudinal plane passing through the torso line and vertical longitudinal planes P and P'.

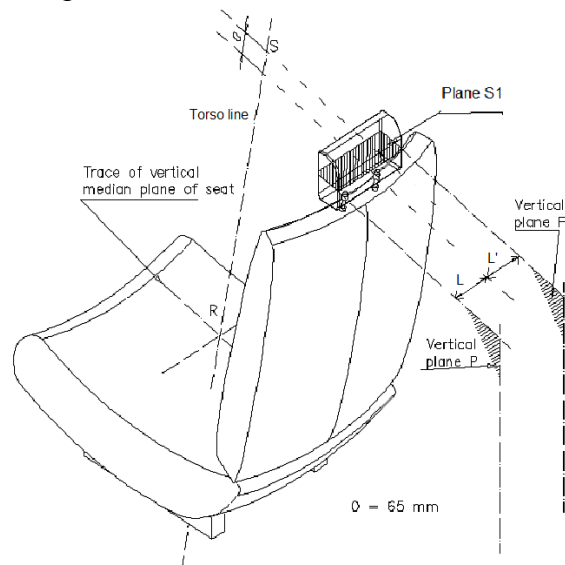

Figure 2-1

Annex 3

GAP MEASUREMENT TEST PROCEDURE

1. PURPOSE

The purpose of this test procedure is to evaluate any gaps within head restraints as well as gaps between the bottom of the head restraint and the top of the seat back, in accordance with the requirements of paragraphs 5.1.3. and 5.1.4. of this regulation.

Any gaps within the head restraint are measured using the sphere procedure described in paragraph 2. of this Annex.

Gaps between the bottom of the head restraint and the top of the seat back are measured using either the sphere procedure described in paragraphs 2.1. through 2.5. of this Annex, or, at the manufacturer option, using the linear procedure described in paragraph 3. of this Annex.

2. GAP MEASUREMENT USING A SPHERE

- 2.1. The seat is adjusted such that its H-point coincides with the R-point; if the seat back is adjustable, it is set at the design seat back angle; both these adjustments are in accordance with the requirements of paragraph 2.1. of Annex 1.
- 2.2. The head restraint is adjusted to its lowest height position and any backset position intended for occupant use.
- 2.3. The area of measurement is anywhere between two vertical longitudinal planes passing at 85 mm on either side of the torso line and above the top of the seat back.
- 2.4. Applying a load of no more than 5 N against the area of measurement specified in paragraph 2.3. above, place a 165 ± 2 mm diameter spherical head form against any gap such that at least two points of contact are made within the area.
- 2.5. Determine the gap dimension by measuring the straight line distance between the inner edges of the two furthest contact points, as shown in Figures 3-1 and 3-2.
- 2.6. For gaps within the head restraint, if the measurement determined in paragraph 2.5 of this Annex exceeds 60 mm, then in order to demonstrate compliance with the requirements of paragraph 5.1.3. of this regulation, the seat back displacement test procedure described in Annex 6 is performed, by applying to each gap, using a sphere of 165 mm in diameter,

a force passing through the centre of gravity of the smallest of the sections of the gap, along transversal planes parallel to the torso line, and reproducing a moment of 373 Nm about the R point.

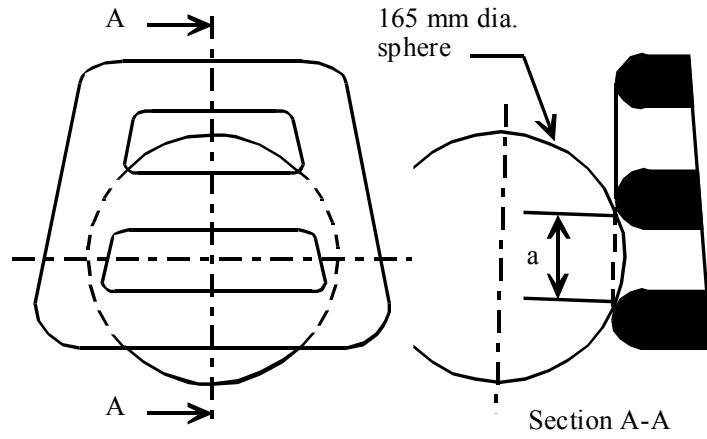

Figure 3-1 - Measurement of a vertical gap "a".

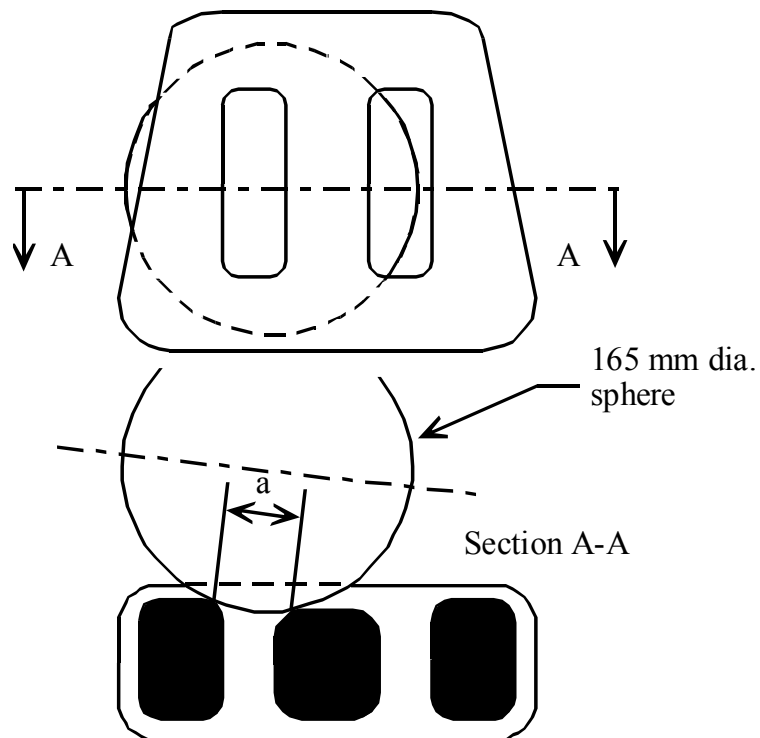

Figure 3-2 - Measurement of a horizontal gap "a".

3. LINEAR MEASUREMENT OF GAP

- 3.1. The seat is adjusted such that its H-point coincides with the R-point; if the seat back is adjustable, it is set at the design seat back angle; both these adjustments are in accordance with the requirements of paragraph 2.1. of Annex 1.
- 3.2. The head restraint is adjusted to its lowest height position and any backset position intended for occupant use.
- 3.3. The gap between the bottom of the head restraint and the top of the seat is measured as the perpendicular distance between two parallel planes, described as follows (see Figure 3-3).
 - 3.3.1. Each plane is perpendicular to the design torso line.
 - 3.3.2. One of the planes is tangent to the bottom of the head restraint.
 - 3.3.3. The other plane is tangent to the top of the seat back.

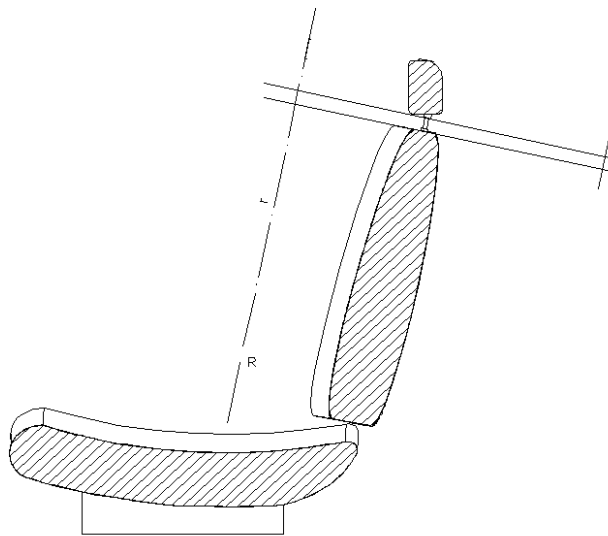

Figure 3-3

Annex 4

BACKSET MEASUREMENT TEST PROCEDURE USING THE HRMD METHOD

1. PURPOSE

Demonstrate compliance with paragraph 5.1.5.2. by measuring the backset using the H-point as the reference point.

2. PROCEDURE FOR BACKSET MEASUREMENT USING H-POINT AS THE REFERENCE POINT

Demonstrate compliance with paragraph 5.1.5.2. by measuring the backset of the head restraint using the three-dimensional H-point machine, defined in Annex 13, and the HRMD (Figure 4-1). This procedure uses the H-point as the reference point.

- 2.1. The test vehicle is levelled using the door sill (front to rear level) and centre luggage compartment (side to side level) as reference points.
- 2.2. The test vehicle is preconditioned at a temperature of $20\text{ °C} \pm 10\text{ °C}$ to ensure that the seat material reaches room temperature.
- 2.3. Remove the head room probe from the three-dimensional H-point machine and install the two washers (supplied with the HRMD) in the spaces remaining on the H-point pivot.
- 2.4. Set up the seat as described in Annex 12, paragraph 3.3. If the seat back is adjustable, it is set at an initial inclination position closest to design angle as measured by the three-dimensional H-point machine. If there is more than one inclination position closest to design angle, set the seat back inclination to the position closest to and rearward of the design angle.
- 2.5. Set up the H-point machine as described in Annex 12, paragraphs 3.4. through 3.10.
- 2.6. Confirm the H-point assembly is level, facing directly forward and located in the centreline of the vehicle seat. As necessary reposition the seat pan.
- 2.7. Install the right and left buttock weights. Install four of the torso weights used in Annex 12, paragraph 3.11., and the two larger HRMD chest weights; alternating left to right. The HRMD torso weights are installed last and with the flat side down. Maintain H-point machine level.
- 2.8. Confirm the actual torso angle is $\pm 1^\circ$ of the design torso angle by placing an inclinometer on the lower brace of the torso weight hangers. If the measured angle is outside this range, if possible adjust the seat back angle

to be $\pm 1^\circ$ of the design seat back angle. If an adjustment is made, remove the buttock and torso weights and repeat the steps contained in paragraphs 3.9. through 3.10. of Annex 12, along with steps as described in paragraphs 2.6. and 2.7. of this Annex until the actual torso angle is $\pm 1^\circ$ of the design seat back angle.

- 2.9. Perform the steps contained in paragraph 3.12. of Annex 12.
- 2.10. Attach the HRMD to the three-dimensional H-point machine.
- 2.11. Confirm the actual torso angle remained $\pm 1^\circ$ of the design seat back angle by placing an inclinometer on the lower brace of the torso weight hangers. If the actual torso angle is outside this range, if possible carefully adjust the seat back angle to be $\pm 1^\circ$ of the design seat back angle. If the legs and seat pan of the three-dimensional H-point machine move during this procedure, remove the HRMD, the buttock and torso weights, and repeat the steps contained in paragraphs 3.9. through 3.11. of Annex 12, along with steps as described in paragraphs 2.6. through 2.10. of this Annex until the actual torso angle is $\pm 1^\circ$ of the design seat back angle.
- 2.12. Level the HRMD and extend the sliding scale on the back of the head until it contacts the head restraint. Confirm that the scale is positioned laterally within 15 mm of the torso line and take the backset measurement.

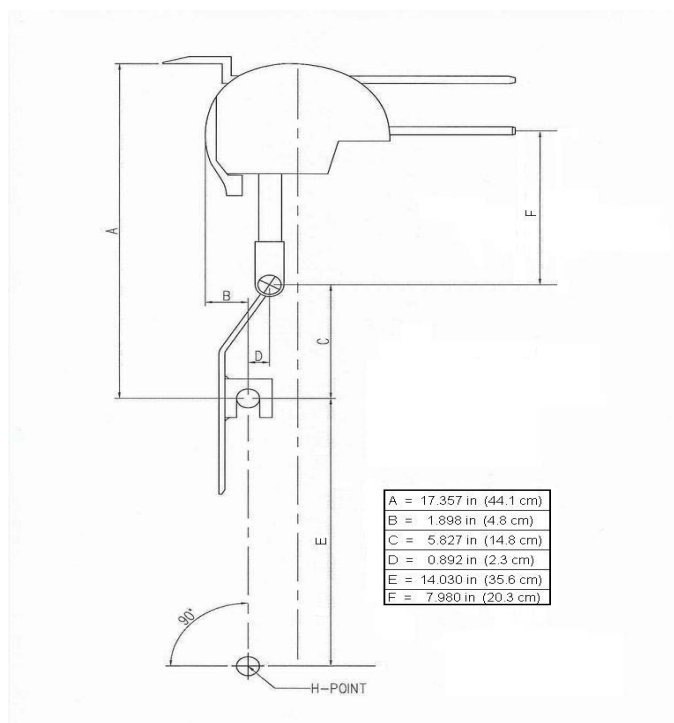

Figure 4-1

Annex 5

BACKSET MEASUREMENT TEST PROCEDURE USING THE R-POINT
METHOD

1. PURPOSE

Demonstrate compliance with paragraph 5.1.5.2. by measuring the backset using the R-point as the reference point.

2. PROCEDURE FOR BACKSET MEASUREMENT USING R-POINT AS THE REFERENCE POINT

Demonstrate compliance with paragraph 5.1.5.2. by measuring the backset of the head restraint using the backset measurement apparatus defined in paragraph 2.1. of this Annex and the following procedures:

2.1. Backset measuring apparatus

The backset measurement apparatus consists of (see Figure 5-2):

2.1.1. A straight edge (lower arm) AB. The lower point A is placed at the R point location. Point B is located at a distance of 504.5 mm from the R point. The line AB is 2.6 degrees forward of the design torso angle.

2.1.2. A vertical straight edge (upper arm) BC. Point C is located at a distance of 203 mm vertically up from point B.

2.2. Adjust the seat such that its H-point coincides with the R-point, in accordance with the following requirements.

2.2.1. Relationship between the H-point and the R-point

When the seat is positioned in accordance to the manufacturer's specifications, the H-point, as defined by its co-ordinates, shall lie within a square of 50 mm side length with horizontal and vertical sides whose diagonals intersect at the R-point, and the actual torso angle is within 5 degree of the design torso angle.

2.2.2. If these conditions are met, the R-point and the design torso angle are used to demonstrate compliance with the provisions of paragraph 5.1.5.2. of this regulation.

2.2.3. If the H-point or the actual torso angle does not satisfy the requirements of paragraph 2.2.1., the H-point and the actual torso angle are determined twice more (three times in all). If the results of two of these three operations satisfy the requirements, the conditions of paragraph 2.2.2. shall

apply.

- 2.2.4. If the results of at least two of the three operations described in paragraph 2.2.3. do not satisfy the requirements of paragraph 2.2.1. the centroid of the three measured points or the average of the three measured angles is used and be regarded as applicable in all cases where the R-point or the design torso angle is referred to in this Annex.
- 2.3. Adjust the seat back to its design angle.
- 2.4. Adjust the front head restraint so that its top is at any height between and inclusive of 750 mm and 800 mm. If the lowest position of adjustment is above 800mm, adjust the head restraint to that lowest position of adjustment.
- 2.5. In the case of head restraint with adjustable backset, adjust the head restraint at the most rearward position, such that the backset is in the maximum position.
- 2.6. Establish point D on the head restraint, point D being the intersection of a line drawn from point C horizontally in the x-direction, with the front surface of the head restraint.
- 2.7. Measure the distance CD. The backset is the measured distance CD minus 71 mm.

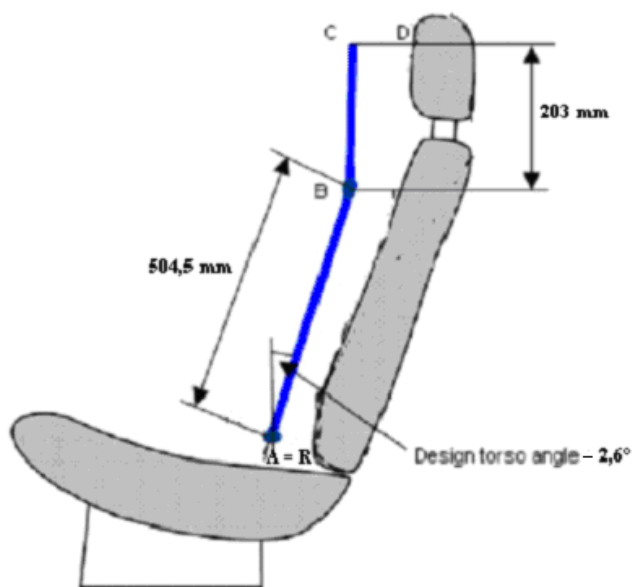

Figure 5-2

Annex 6

DISPLACEMENT, BACKSET RETENTION, AND STRENGTH TEST
PROCEDURE

1. PURPOSE

Demonstrate compliance with the displacement requirements of paragraph 5.1.3. of this regulation with paragraph 2. of this Annex.

Demonstrate compliance with the displacement requirements of paragraph 5.2.3.3. of this regulation with paragraph 2. of this Annex.

Demonstrate compliance with the displacement and backset retention requirements of paragraph 5.2.3.2. of this regulation with paragraph 3. of this Annex.

Demonstrate compliance with the strength requirements of paragraph 5.2.4. of this regulation with paragraph 4. of this Annex.

2. PROCEDURE FOR DISPLACEMENT

The load vectors that generate moment on the head restraint are initially contained in a vertical plane parallel to the vertical longitudinal zero plane.

2.1. Seat set-up

If the seat back is adjustable, it is adjusted to a position specified by the vehicle manufacturer. If there is more than one inclination position closest to the position specified by the manufacturer, set the seat back inclination to the position closest to and rearward of the manufacturer specified position. If the head restraint position is independent of the seat back inclination position, compliance is determined at a seat back inclination position specified by the manufacturer. Adjust the head restraint to the highest position of vertical adjustment intended for occupant use. Adjust the head restraint to the rearmost (relative to the seat) position of horizontal adjustment backset position.

2.2. In the seat, place a test device having, when viewed laterally, the back pan dimensions and torso line (vertical centre line) of the three dimensional H-point machine, as specified in Annex 13, with the head room probe in the full back position.

2.3. Establish the displaced torso line by creating a rearward moment of 373 ± 7.5 Nm about the R-point by applying a force to the seat back through the back pan at the rate of 2.5 Nm/second to 37.3 Nm/second. The initial location on the back pan of the moment generating force vector

has a height of 290 mm \pm 13 mm. Apply the force vector normal to the torso line and maintain it within 2 degrees of a vertical plane parallel to the vehicle vertical longitudinal zero plane. Constrain the back pan to rotate about the R-point. Rotate the force vector direction with the back pan.

- 2.4. Maintain the position of the back pan as established in paragraph 2.3. of this Annex. Using a 165 \pm 2 mm diameter spherical head form, establish the head form initial reference position by applying, perpendicular to the displaced torso line, a rearward initial load at the seat centreline at a height 65 \pm 3 mm below the top of the head restraint that will produce a 373 Nm moment about the R-point. After maintaining this moment for 5 seconds, measure the rearward displacement of the head form during the application of the load.
- 2.5. When determining the rearward displacement for head restraints at a gap greater than 60 mm in accordance with paragraph 5.1.3. of this regulation, the load of paragraph 2.4. of this Annex is applied through the centre of gravity of the smallest of the sections of the gap, along transversal planes parallel to the torso line.
- 2.6. If the presence of gaps prevents the application of the force, as described in paragraph 2.4. of this Annex at 65 \pm 3 mm from the top of the head restraint, the distance may be reduced so that the axis of the force passes through the centre line of the frame element nearest to the gap.

3. PROCEDURES FOR BACKSET RETENTION AND DISPLACEMENT

- 3.1. If the seat back is adjustable, it is adjusted to a position specified by the vehicle manufacturer. If there is more than one inclination position closest to the position specified by the manufacturer, set the seat back inclination to the position closest to and rearward of the manufacturer specified position. If the head restraint position is independent of the seat back inclination position, compliance is determined at a seat back inclination position specified by the manufacturer. Adjust the head restraint to the highest position of vertical adjustment intended for occupant use.
- 3.2. Adjust the head restraint to any backset position.
- 3.3. In the seat, place a test device having the back pan dimensions and torso line (vertical centre line), when viewed laterally, with the head room probe in the full back position, of the three-dimensional H-point machine.
- 3.4. Establish the displaced torso line by creating a rearward moment of 373 \pm 7.5 Nm about the R-point by applying a force to the seat back through the back pan at the rate between 2.5 Nm/second and 37.3 Nm/second. The initial location on the back pan of the moment

generating force vector has a height of $290 \text{ mm} \pm 13 \text{ mm}$. Apply the force vector normal to the torso line and maintain it within 2 degrees of a vertical plane parallel to the vehicle vertical longitudinal zero plane. Constrain the back pan to rotate about the R-point. Rotate the force vector direction with the back pan.

- 3.5 Maintain the position of the back pan as established in paragraph 3.4. of this Annex. Using a $165 \pm 2 \text{ mm}$ diameter spherical head form, establish the head form initial reference position by applying, perpendicular to the displaced torso line, a rearward initial load at the seat centreline at a height $65 \pm 3 \text{ mm}$ below the top of the head restraint that will produce a 37 Nm moment about the R-point. Measure the rearward displacement of the head form during the application of the load.
- 3.6. If the presence of gaps prevents the application of the forces, as described in paragraph 3.5. of this Annex at $65 \pm 3 \text{ mm}$ from the top of the head restraint, the distance may be reduced so that the axis of the force passes through the centre line of the frame element nearest to the gap.
- 3.7. Increase the initial load at the rate of 2.5 Nm/second to 37.3 Nm/second until a 37.3 Nm moment about the R-point is produced. Maintain the load level producing that moment for not less than 5 seconds and then measure the rearward displacement of the head form relative to the displaced torso line.
- 3.8. Reduce the load at the rate of 2.5 Nm/second to 37.3 Nm/second until 0 Nm. Wait 10 minutes. Re-load to 37 Nm about the R-point. While maintaining the load level producing that moment, measure the rearward displacement of the head form position with respect to its initial reference position.

4. STRENGTH

Increase the load specified in paragraph 2.6. or paragraph 3.8. of this Annex at the rate between 5 N/second and 200 N/second to at least 890 N and maintain the applied load for not less than 5 seconds.

Annex 7

ENERGY ABSORPTION TEST PROCEDURE

1. PURPOSE

Evaluate the energy absorption ability of the head restraint by demonstrating compliance with paragraph 5.2.1. of this regulation in accordance with this Annex.

2. SEAT SET-UP

The seat is either mounted in the vehicle or firmly secured to the test bench, as mounted in the vehicle with the attachment parts provided by the manufacturer, so as to remain stationary when the impact is applied. The seat-back, if adjustable, is locked in the design position specified by the vehicle manufacturer. If the seat is fitted with a head restraint, the head restraint is mounted on the seat-back as in the vehicle. Where the head restraint is separate, it is secured to the part of the vehicle structure to which it is normally attached.

3. PROCEDURES FOR ENERGY ABSORPTION

The adjustable head restraints are measured in any height and backset position of adjustment.

3.1. Test equipment

3.1.1. Use an impactor with a semispherical head form of a 165 ± 2 mm diameter. The head form and associated base have a combined mass such that at a speed of not more than 24.1 km/h at the time of impact an energy of 152 Joule will be reached.

3.1.2. Instrument the impactor with an acceleration sensing device whose output is recorded in a data channel that conforms to the requirements for a 600 Hz channel class filter as specified in ISO Standard 6487 (2002). The axis of the acceleration-sensing device coincides with the geometric center of the head form and the direction of impact. As an alternative the impactor can be equipped with 2 accelerometers sensing in the direction of impact and placed symmetrically in comparison to the geometric centre of the spherical head form. In this case the deceleration rate is taken as the simultaneous average of the readings on the two accelerometers.

3.2. Accuracy of the test equipment

The recording instrument used is such that measurements can be made with the following degrees of accuracy:

3.2.1. Acceleration:

Accuracy = + 5 per cent of the actual value;
Cross-axis sensitivity = < 5 per cent of the lowest point on the scale.

3.2.2. Speed:

Accuracy: + 2.5 per cent of the actual value;
Sensitivity: 0.5 km/h.

3.2.3. Time recording:

The instrumentation shall enable the action to be recorded throughout its duration and readings to be made to within one one-thousandth of a second; the beginning of the impact at the moment of first contact between the head form and the item being tested is detected on the recordings used for analyzing the test.

3.3. Test procedure

3.3.1. Propel the impactor toward the head restraint. At the time of impact, the longitudinal axis of the impactor is within ± 2 degrees of being horizontal and parallel to the vehicle longitudinal axis and the impactor speed is not more than 24.1 km/h.

3.3.2. Impact the front surface of the head restraint at any point with a height greater than 635 mm from the R-point and within a distance of the head restraint vertical centre line of 70 mm and measure the acceleration.

Annex 8

HEIGHT RETENTION TEST PROCEDURE

1. PURPOSE

Demonstrate compliance with the height retention requirements of paragraph 5.2.2. of this regulation in accordance with this Annex.

2. PROCEDURES FOR HEIGHT RETENTION

2.1. Seat set-up

Adjust the adjustable head restraint so that its top is at any of the following height positions at any backset position:

2.1.1. For front outboard designated seating positions:

2.1.1.1. The highest position; and

2.1.1.2. Not less than, but closest to 800 mm

2.1.2. For rear outboard and front centre designated seating positions

2.1.2.1. The highest position; and

2.1.2.2. Not less than, but closest to 750 mm.

2.1.3. For rear centre designated seating position

2.1.3.1. The highest position; and

2.1.3.2. Not less than, but closest to 700 mm.

2.2. Orient a cylindrical test device having a 165 ± 2 mm diameter in plane view (perpendicular to the axis of revolution), and a 152 mm length in profile (through the axis of revolution), such that the axis of the revolution is horizontal and in the longitudinal vertical plane through the vertical longitudinal zero plane of the head restraint. Position the midpoint of the bottom surface of the cylinder in contact with the head restraint.2.3. Establish initial reference position by applying a vertical downward load of 50 ± 1 N at a rate of 250 ± 50 N/minute. Determine the reference position after 5 seconds at this load. Mark an initial reference position for the head restraint.

- 2.4. Measure the vertical distance between the lowest point on the underside of the head restraint and the top of the seat back. (see paragraph 2.9. of this Annex)
- 2.5. Increase the load at the rate of 250 ± 50 N/minute to at least 500 N and maintain this load for not less than 5 seconds.
- 2.6. Reduce the load at a rate of 250 ± 50 N/m until the load is completely removed. Maintain this condition for no more than two minutes. Increase the load at a rate of 250 ± 50 N/minute to 50 ± 1 N and, after 5 seconds at this load, determine the position of the cylindrical device with respect to its initial reference position.
- 2.7. Repeat the measurement of the vertical distance measured between the lowest point on the underside of the head restraint and the top of the seat back. (see paragraph 2.9. of this Annex)
- 2.8. Compare the measurements from paragraphs 2.4. and 2.7. of this Annex. The difference is the measurement required to comply with paragraph 5.2.2. of this regulation.
- 2.9. If the design of the head restraint is such that it is not possible to measure to the top of the seat then the vertical measurement is taken by marking a horizontal line across the front of the seat back at least 25 mm below the lowest point of the head restraint and the measurement is taken from this line to the underside of the head restraint.

Annex 9

DYNAMIC PERFORMANCE TEST PROCEDURE

1. PURPOSE

~~Demonstrate compliance with paragraph 5.3. in accordance with this Annex, using a 50th percentile male Hybrid III test dummy.~~

[Demonstrate compliance with paragraph 5.3. of this Regulation in accordance with this Annex, using a 50th percentile male BioRID II test dummy.]

2. TEST EQUIPMENT

2.1. An acceleration or deceleration test sled

2.2. 50th percentile male test dummy

2.2.1. [BioRID II]

~~2.2.1.1. Three accelerometers are in the head cavity to measure orthogonal accelerations at the centre of gravity of the head assembly. The three accelerometers are mounted in an orthogonal array, and the intersection of the planes containing the sensitivity axis of the three sensors will be the origin of the array.~~

~~2.2.3. Equipment for measuring the head to torso angle.~~

~~2.2.4. Equipment for measuring and recording sled accelerations.~~

2.2.1.1. [Spine Curvature Check]

With the pelvis adapter plate placed on a level surface, the spine stature shall meet the specifications defined in Table 9-1 and Figure 9-1. The curvature check shall be performed after every 15 tests and all measurements shall be recorded and fully documented.

Table 9-1 BioRID IIg spine curvature specifications

Measurement	Specification
Angle of occipital interface plate relative to horizontal	29.5±0.5 degrees
Angle of T2 vertebra relative to horizontal	37.0±0.5 degrees
Angle of neck plate (lateral)	0±0.5 degrees
H-point indicator to occipital condyle pin (horizontal)	156±5mm
H-point indicator to occipital condyle pin (vertical)	609±5mm

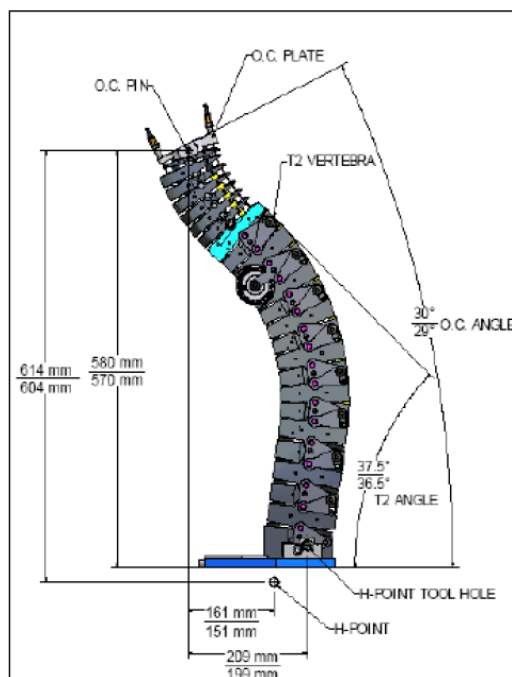

Figure 9-1 Spine curvature check

2.2.1.2 Calibration

The properties of each part of the dummy shall be verified using BioRID II User's Manual (29 July 2008) and shall conform to its specifications.]

3. PROCEDURES FOR TEST SET-UP

~~3.1. Mount the vehicle on a dynamic test platform so that the vertical-longitudinal zero plane of the vehicle is parallel to the direction of the test platform travel and so that movement between the base of the vehicle and the test platform is prevented. Instrument the platform with an accelerometer and data processing system. Position the accelerometer-sensitive axis parallel to the direction of test platform travel.~~

[3.1. Mount the seat, including all of its adjustment mechanisms and hardware that normally connects it to the vehicle floor and toe board which consists of a horizontal section and a section oriented 45° from the horizontal, or vehicle body in white as appropriate according to paragraph 6 of this regulation on a dynamic test platform so that the seat's orientation relative to the horizontal is the same as it would be in its vehicle and so that movement between the attachment hardware and the test platform is prevented. The gap between the front of the seat and rear of the toe board shall be no more than 100 mm. Instrument the platform with an accelerometer and data processing system.

Position the accelerometer sensitive axis parallel to the direction of test platform travel.]

~~3.2. Remove the tires, wheels, fluids, and all unsecured components. Rigidly secure the engine, transmission, axles, exhaust system, vehicle frame and any other vehicle component necessary to assure that all points on the acceleration vs. time plot measured by an accelerometer on the dynamic test platform fall within the corridor described in Figure 9-1 and Table 9-1.~~

~~3.3. Place any moveable windows in the fully open position.~~

~~3.4. Seat Adjustment~~

[3.2.] Seat Adjustment

~~3.4.1. At each designated seating position, if the seat back is adjustable, it is set at an initial inclination position closest to 25 degrees from the vertical, as measured by the three-dimensional H-point machine, as specified in Annex 13. If there is more than one inclination position closest to 25 degrees from the vertical, set the seat back inclination to the position closest to and rearward of 25 degrees.~~

[3.2.1. For each seat to be tested, if the seat back is adjustable, it shall be set to its design angle.]

~~3.4.2. Using any control that primarily moves the entire seat vertically, place the seat in the lowest position. Using any control that primarily moves the entire seat in the fore and aft directions, place the seat midway between the forwardmost and rearmost position. If an adjustment position does not exist midway between the forwardmost and rearmost positions, the closest adjustment position to the rear of the midpoint is used.~~

[3.2.2. Using any control that primarily moves the entire seat vertically, place the seat in the mid height position. Using any control that primarily moves the entire seat in the fore and aft directions, place the seat midway between the most forward and most rearward position. If an adjustment position does not exist midway between those positions, the closest adjustment position to the rear of the midpoint shall be used.]

~~3.4.3. If the seat cushion adjusts independently of the seat back, position the seat cushion such that the highest H-point position is achieved with respect to the seat back, as measured by three-dimensional H-point machine as specified in Annex 13. If the specified position of the H-point can be achieved with a range of seat cushion inclination angles, adjust the seat inclination such that the most forward part of the seat cushion is at its lowest position with respect to the most rearward part.~~

[3.2.3.] If the seat cushion adjusts independently of the seat back, position the seat cushion such that the highest H-point position is achieved with respect to the seat back, measured by three-dimensional H-point machine as specified in Annex 13. If the specified position of the H-point can be achieved with a range of seat cushion inclination angles, adjust the seat inclination such that the most forward part of the seat cushion is at its lowest position with respect to the most rearward part. **Side bolsters shall be set to the widest position. Arm rests shall be set in the stowed position.]**

~~3.4.4. If the head restraint is adjustable, adjust the top of the head restraint to a position midway between the lowest position of adjustment and the highest position of adjustment. If an adjustment position midway between the lowest and the highest position does not exist, adjust the head restraint to a position below and nearest to midway between the lowest position of adjustment and the highest position of adjustment.~~

[3.2.4.] If the head restraint is adjustable, adjust the top of the head restraint to a position midway between the lowest position of adjustment and the highest position of adjustment. If an adjustment position midway between the lowest and the highest position does not exist, adjust the head restraint to the position **determined by the next process. If a hard locking position exists within 10 mm vertically upwards from the geometric mid-position, this shall be the test position. If no hard locking position exists within 10 mm vertically upwards from the geometric mid-position then the next hard locking position down shall be the test position. When the head restraint has a locking fore-aft adjustment, it shall be in the midpoint. If non-locking, the head restraint shall be tilted fully rearward.]**

~~3.4.5. Adjustable lumbar supports are positioned so that the lumbar support is in its lowest retracted or deflated position.—~~

[3.2.5.] Adjustable lumbar supports **shall be** positioned so that the lumbar support is in its lowest retracted or deflated position.]

~~3.5. Seat Belt Adjustment~~

[3.3.] Seat Belt Adjustment
Prior to placing the seat belt around the test dummy, fully extend the webbing from the seat belt retractor(s) and release it three times to remove slack. If an upper adjustable seat belt turning loop (adjustable seat belt D-ring anchorage) exists, place it in the adjustment position closest to the mid-position. If an adjustment position does not exist midway between the highest and lowest position, the closest adjustment position above the midpoint is used.
When using the seat belt, prior to placing the seat belt around the test

dummy, fully extend the webbing from the seat belt retractor(s) and release it three times to remove slack. If an upper adjustable seat belt turning loop (adjustable seat belt D-ring anchorage) exists, place it in the adjustment position closest to the mid-position. If an adjustment position does not exist midway between the highest and lowest position, the closest adjustment position above the midpoint **shall be used.**]

~~3.6. Dress and adjust each test dummy as follows:~~

[3.4. Dress and adjust each test dummy as follows:
Each test dummy is clothed in a form fitting cotton stretch short sleeve shirt with above the elbow sleeves and above the knee length pants. The mass of the shirt or pants shall not exceed 0.06 kg each. Each foot of the test dummy is equipped with a size 11XW shoe whose mass is 0.51 ± 0.09 kg. Limb joints are set at 1g, barely restraining the weight of the limb when extended horizontally. Leg joints are adjusted with the torso in the supine position.

The dummy shall be dressed with two pairs of close-fitting, knee-length, spandex/lycra pants and two close-fitting, short-sleeved spandex shirts. The under layer of clothes shall be worn with the shiny/smooth side of the fabric facing out and the over-clothes with the shiny/smooth side against the underclothes (i.e. dull side facing out). The dummies feet shall be fitted with size 11 (45 European or 279mm) Oxford-style, hard-soled, work shoes (e.g. MIL-S-13192P).]

~~3.7. Hybrid III Test dummy positioning procedure~~

~~Place a test dummy at each designated seating position equipped with a head restraint.~~

[3.5. BioRID II Test dummy positioning procedure.

3.5.1 According to paragraph 2 of Annex 4, the seat shall have already been set to give the design torso angle ± 1 degree measured on the H-Point machine fitted with HRMD (see Annex 4).

Place the test dummy in the seating position equipped with a head restraint after allowing the seat to recover for 15 minutes with nothing in it.]

~~3.7.1. Head~~

~~The transverse instrumentation platform of the head is level within 1/2 degree. To level the head of the test dummy, the following sequence is followed. First, adjust the position of the H point 1/ to level the transverse instrumentation platform of the head of the test dummy. If the~~

~~transverse instrumentation platform of the head is still not level, then adjust the pelvic angle of the test dummy. If the transverse instrumentation platform of the head is still not level, then adjust the neck bracket of the dummy the minimum amount necessary from the non-adjusted "0" setting to ensure that the transverse instrumentation platform of the head is horizontal within 1/2 degree. The test dummy remains within the limits specified in 1/ after any adjustment of the neck bracket.~~

~~3.7.2. Upper arms and hands~~

~~Position each test dummy as specified below:~~

~~3.7.2.1. The driver's upper arms shall be adjacent to the torso with the centre lines as close to a vertical plane as possible.~~

~~3.7.2.2. The passenger's upper arms are in contact with the seat back and the sides of the torso.~~

~~3.7.2.3. The palms of the drivers test dummy are in contact with the outer part of the steering wheel rim at the rim's horizontal centre line. The thumbs are over the steering wheel rim and are lightly taped to the steering wheel rim so that if the hand of the test dummy is pushed upward by a force of not less than 0.91 kg and not more than 2.27 kg, the tape shall release the hand from the steering wheel rim.~~

~~3.7.2.4. The palms of the passenger test dummy are in contact with the outside of the thigh. The little finger is in contact with the seat cushion.~~

~~3.7.3. Upper Torso~~

~~Position each test dummy such that the upper torso rests against the seat back. The midsagittal plane of the dummy is aligned within 15 mm of the head restraint centreline. If the midsagittal plane of the dummy cannot be aligned within 15 mm of the head restraint centreline then align the midsagittal plane of the dummy as close as possible to the head restraint centreline.~~

~~3.7.4. Lower Torso~~

~~1/ The H points of the driver and passenger test dummies shall coincide within 12.5 mm in the vertical dimension and 12.5 mm in the horizontal dimension of a point 6.25 mm below the position of the H point determined by using the equipment and procedures specified in except that the length of the lower leg and thigh segments of the H point machine shall be adjusted to 414 mm and 401 mm, respectively.~~

~~————— The H-points of the driver and passenger test dummies shall coincide within 12.5 mm in the vertical dimension and 12.5 mm in the horizontal dimension of a point 6.25 mm below the position of the H-point determined by the manikin defined in Annexes 12 and 13.~~

3.7.5. ~~————— Pelvic Angle~~

~~————— As determined using the pelvic angle gage which is inserted into the H-point gauging hole of the dummy, the angle measured from the horizontal on the 76 mm flat surface of the gage is 22.5 ± 2.5 degrees.~~

3.7.6. ~~————— Legs~~

~~————— Position each test dummy as follows:~~

~~————— The upper legs of the driver and passenger test dummies shall rest against the seat cushion to the extent permitted by placement of the feet. The initial distance between the outboard knee clevis flange surfaces is 269 mm. To the extent practicable, the left leg of the driver dummy and both legs of the passenger dummy are in vertical longitudinal planes. To the extent practicable, the right leg of the driver dummy is in a vertical plane. Final adjustment to accommodate the placement of feet in various passenger compartment configurations is permitted.~~

3.7.7. ~~————— Feet~~

3.7.7.1. ~~————— Driver's position~~

3.7.7.1.1. ~~————— If the vehicle has an adjustable accelerator pedal, adjust it to the full forward position. Rest the right foot of the test dummy on the undepressed accelerator pedal with the rearmost point of the heel on the floor pan in the plane of the pedal. If the foot cannot be placed on the accelerator pedal, set it initially perpendicular to the lowest leg and then place it as far forward as possible in the direction of the pedal centreline with the rearmost point of the heel resting on the floor pan. If the vehicle has an adjustable accelerator pedal and the right foot is not touching the accelerator pedal when positioned as above, move the pedal rearward until it touches the right foot. If the accelerator pedal still does not touch the foot in the full rearward position, leave the pedal in that position.~~

3.7.7.1.2. ~~————— Place the left foot on the toeboard with the rearmost point of the heel resting on the floor pan as close as possible to the point of intersection of the planes described by the toeboard and the floor pan and not on the wheelwell projection. If the foot cannot be positioned on the toeboard, set it initially perpendicular to the lower leg and place it as far forward as possible with the heel resting on the floor pan. If necessary to avoid~~

~~contact with the vehicle's brake or clutch pedal, rotate the test dummy's left foot about the lower leg. If there is still pedal interference, rotate the left leg outboard about the hip the minimum distance necessary to avoid the pedal interference. For vehicles with a foot rest that does not elevate the left foot above the level of the right foot, place the left foot on the foot rest so that the upper and lower leg centrelines fall in a vertical plane.~~

~~3.7.7.2. Front Passenger's position~~

~~3.7.7.2.1. Vehicles with a flat floor pan/toeboard~~

~~Place the right and left feet on the vehicle's toeboard with the heels resting on the floor pan as close as possible to the intersection point with the toeboard. If the feet cannot be placed flat on the toeboard, set them perpendicular to the lower leg centrelines and place them as far forward as possible with the heels resting on the floor pan.~~

~~3.7.7.2.2. Vehicles with wheelhouse projections in passenger compartment~~

~~Place the right and left feet in the well of the floor pan/toeboard and not on the wheelhouse projection. If the feet cannot be placed flat on the toeboard, initially set them perpendicular to the lower leg centrelines and then place them as far forward as possible with the heels resting on the floor pan.~~

~~3.7.7.3. Rear Passenger's position~~

~~Position each test dummy as specified in paragraph 2.7.7.2. of this Annex, except that feet of the test dummy are placed flat on the floorpan and beneath the front seat as far forward as possible without front seat interference. If necessary, the distance between the knees can be changed in order to place the feet beneath the seat.~~

[3.5.2. Place the seat belt across the dummy and lock as normal.

3.5.3. Align the test dummy's midsagittal plane with the centerline of the seat.

3.5.4. Adjust the test dummy's midsagittal plane to be vertical; the instrumentation platform in the head shall be laterally level.

3.5.5. Adjust the pelvis angle to the actual torso angle recorded by the procedure specified in paragraph 3.5.1 plus 1.5 ± 2.5 degrees.

3.5.6. Position the test dummy's h-point 20 ± 10 mm forward and 0 ± 10 mm vertically of the h-point location measured under the condition

specified in paragraph 2.12 of annex 4, while keeping the pelvis angle within the range specified in paragraph 3.5.5.

3.5.7. Adjust the spacing of the legs so that the centreline of the knees and ankles is 200 mm(± 10 mm) apart and ensure that the knees are level.

3.5.8. Adjust the test dummy's feet and/or the horizontal position of the adjustable toe board so that the heel of the test dummy's shoe is resting on the heel surface. The tip of the shoe shall rest on the toe pan between 230 mm and 270 mm from the intersection of the heel surface and toe board, as measured along the surface of the toe board (see figure 9-2).

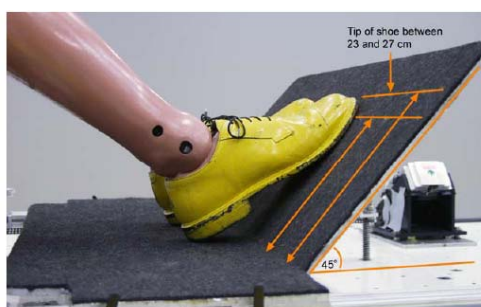

Figure 9-2 proper positioning of the test dummy's feet.

3.5.9. Position the test dummy's arms so that the upper arms are as close to the torso sides as possible. The rear of the upper arms shall contact the seatback, and the elbows shall be bent so that the small fingers of both hands are in contact with the top of the vehicle seat cushion with the palms facing the dummy's thighs.

3.5.10. Level the instrumentation plane of the head (front/rear and left/right directions) to within ± 1 degree.

3.5.11. Measure the test dummy reference backset, which is the horizontal distance between the rearmost point on the head and the same identifiable location on the head restraint. Compare the test dummy reference backset with the hrmd backset obtained by the procedure specified in paragraph 2.12 of annex 4.

3.5.11.1. If the test dummy reference backset is different by more than ± 2 mm from the hrmd backset, obtained by the procedure specified in paragraph 2.12 of annex 4, plus 15 mm, then do the following:

3.5.11.1.1. Tip the head fore/aft no more than ± 1 degree from level in order to meet the backset requirement.

3.5.11.1.2. If the backset cannot be brought closer to the test dummy reference

backset plus 15±2mm by paragraph 3.5.11.1.1 of this Annex, adjust the pelvis angle and H-point position within their respective tolerance bands giving priority to use the pelvis angle tolerance. In this case begin at paragraph 3.5.5 of this Annex and adjust the test dummy position accordingly.

3.5.12. Remove the slack from the lap section of the webbing until it is resting gently around the pelvis of the dummy. Only minimal force shall be applied to the webbing when removing the slack. The route of the lap belt shall be as natural as possible and shall be above the pelvic angle gauge.

3.6 Adjustment of the dummy extremities

3.6.1. Arms

3.6.1.1. Extend the complete arm laterally outward to a horizontal position. Twist the arm so the elbow cannot rotate downward. Tighten the shoulder yoke clevis bolt so the arm is suspended at 1g.

3.6.1.2. Rotate the complete arm assembly so it points forward and is horizontal. Twist the arm so the elbow cannot rotate downward. Adjust the shoulder yoke rotation bolt so the arm is suspended at 1g.

3.6.1.3. Bend the elbow by 90 degrees so the hand moves toward the chest. Adjust the elbow rotation bolt through access in the upper arm to hold the lower arm horizontally suspended at 1g.

- 3.6.1.4. Reposition the arm so it points forward and is horizontal. Twist the lower arm at the elbow, so the lower arm can pivot downward to vertical. Adjust the elbow pivot bolt through access holes in the lower arm flesh at the elbow to hold the lower arm suspended at 1g.**
- 3.6.1.5. Extend the arm and twist the palm so it faces down. Adjust the wrist pivot bolt at the base of the hand so it is suspended at 1g.**
- 3.6.1.6. Adjust the wrist rotation bolt through access in the wrist flesh to hold it suspended at 1g.**
- 3.6.1.7. Repeat the procedure for the other hand and arm.**
- 3.6.2. Legs**
- 3.6.2.1. Remove the jacket from the dummy.**
- 3.6.2.2. With the lower leg at 90 degrees to the upper leg, and the dummy in seated position, lift the upper leg assembly above horizontal. Adjust the femur back set screw so the upper leg is held suspended at 1g.**
- 3.6.2.3. Rotate the lower leg assembly so it is horizontal. Adjust the knee clevis bolt so the lower leg is held suspended at 1g.**
- 3.6.2.4. Adjust the ankle ball joint screw so the foot is held suspended at 1g. The ankle adjustment is not critical and is determined by individual feet.**
- 3.6.2.5. Repeat the procedure on the other leg and foot.]**
- ~~3.8. All tests specified by this standard are conducted at an ambient temperature of 18 to 28 °C.~~
- [3.7. All tests specified in this Annex shall be conducted at an ambient temperature of 22 ± 3 °C and a relative humidity of between 10 per cent and 70 per cent. The dummy and seat being tested shall be soaked at this temperature at least three hours prior to the test.]**
- ~~3.9 All tests are performed with the ignition "on."~~
- [3.8. All tests are performed with the ignition "on", or active elements (e.g. Active head restraint, Seat belt pretensioner) which operate in a rear impact situation in an armed condition. For each element that requires a trigger, time to fire (TTF) should be specified by the vehicle manufacturer.]**
- 4. TEST PROCEDURE**

- ~~4.1. Accelerate or decelerate the dynamic test platform to reach a delta V of 17.3 ± 0.6 km/h. All of the points on the acceleration vs. time curve fall within the corridor described in Figure 9-1 and Table 9-1 when filtered to channel class 60, as specified in the SAE Recommended Practice J211/1 (revision March 1995). Measure the maximum rearward angular displacement.~~
- ~~4.2. Calculate the angular displacement from the output of instrumentation placed in the torso and head of the test dummy and an algorithm capable of determining the relative angular displacement to within one degree and conforming to the requirements of a 600 Hz channel class, as specified in SAE Recommended Practice J211/1, (revision March 1995). No data generated after 200 ms from the beginning of the forward acceleration are used in determining angular displacement of the head with respect to the torso.~~
- ~~4.3. Calculate the HIC15 from the output of instrumentation placed in the head of the test dummy, using the equation in paragraph 5.3.2.3. of this regulation and conforming to the requirements for a 1,000 Hz channel class as specified in SAE Recommended Practice J211/1 (revision March 1995). No data generated after 200 ms from the beginning of the forward acceleration are used in determining HIC.~~

[4.1. The corridors for the pulse are illustrated in Figure 9-3. The sled acceleration shall be adjusted within the corridors in Table 9-2 for the complete time interval from 0 to 0.15s. The sled pulse shall fulfil the requirements as specified in Table 9-3.

4.1.1. Data processing and definitions.

4.1.1.1. Filter with CFC 60.

To ensure that low level noise does not influence the results, the acceleration signal shall be filtered with a CFC60 filter. The CFC60 filter shall be used according to SAE J211, for sled acceleration signals.

4.1.1.2. T_0 definition.

The T_0 (T_{zero}) shall be defined as the time 5.8 ms before the CFC60 filtered sled acceleration reaches a 1.0g level.

4.1.1.3. T-HRC_(end) definition.

The time when the CFC60 filtered sled acceleration for the first time is $< 0g$ shall be called T-HRC_(end) .

4.1.1.4. Time span definition

The time span for sled pulse corridor shall be defined as $dT = T-HRC_{(end)} - T_0$.

4.2. Measurements to be recorded

The electrical measurement data for the following parameters from the accelerometers and load cells mounted on the corresponding parts of the dummy and on the test sled shall be recorded from 20 ms before impact to 300 ms after impact or longer.

Longitudinal acceleration at the dummy's head

Longitudinal force at the dummy's upper neck

Vertical force at the dummy's upper neck

Lateral axial rotation moment at the dummy's upper neck

Longitudinal force at the dummy's lower neck

Vertical force at the dummy's lower neck

Lateral axial rotation moment at the dummy's lower neck

Longitudinal acceleration on the right side of the dummy's T1 vertebra

Vertical acceleration on the right side of the dummy's T1 vertebra

Longitudinal acceleration on the left side of the dummy's T1 vertebra

Vertical acceleration on the left side of the dummy's T1 vertebra

Signal of contact between the back of the dummy's head and the head restraint

4.3 Calculation of the injury criteria

The injury criteria for the dummy shall be calculated, using the following method, from the waveform determined in paragraph 5.2.

[4.3.1 Head and head restraint contact time (T-HRCstart, T-HRCend)

Head restraint contact time start, T-HRCstart, is defined as the time (calculated from T=0) of first contact between the back of the

dummy's head and the head restraint, where the subsequent continuous contact duration exceeds 40 ms. T-HRCstart shall be expressed in ms and rounded to one decimal place. Two decimal places of contact time (up to 1 ms) are permissible if it can be proven that these are due to poor electrical contacts; however, these must be investigated with reference to the film to ascertain whether the breaks in contact are not due to biomechanical phenomena such as dummy ramping, head restraint or seatback collapse, or 'bounce' of the head during non-structural contact with the head restraint. For the subsequent criteria, the end of head restraint contact, i.e., T-HRCend, must also be found. This is defined as the time at which the head first loses contact with the head restraint, where the subsequent continuous loss of contact duration exceeds 40 ms.]

4.3.1. Neck Injury Criterion (NIC)

The NIC is determined based on the velocity of the head relative to the T1 vertebra and horizontal acceleration. Each acceleration shall be calculated in meters per second squared (m/s²), and the head's longitudinal acceleration shall be filtered at CFC 60. The T1 vertebra acceleration is measured on either side, but in the NIC calculation, the average of the left and right accelerations, which have both been filtered at CFC 60, shall be used. This average acceleration is determined as follows:

$$T1(t) = \frac{T1_{left}(t) + T1_{right}(t)}{2}$$

T1left(t) = Acceleration measured by accelerometer on the left side of the T1 vertebra

T1right(t) = Acceleration measured by accelerometer on the right side of the T1 vertebra

The "relative longitudinal acceleration" between the head and T1 vertebra (γ_x^{rel}) shall be generated by subtracting the head longitudinal acceleration (γ_x^{Head}) from the left-right average of the T1 vertebra longitudinal acceleration (γ_x^{T1}).

This acceleration is calculated as follows:

$$\gamma_x^{rel} = \gamma_x^{T1} - \gamma_x^{Head}$$

The "relative longitudinal velocity" between the head and T1 vertebra (V_x^{rel}) shall be calculated, by integrating the relative acceleration with respect to time, as follows:

$$V_x^{rel}(t) = \int_0^t \gamma_x^{rel}(\tau) d\tau$$

The NIC channel is then calculated as a combination of relative acceleration multiplied by 0.2, and added to the square of the relative velocity. The calculation is performed using the following equation:

$$NIC(t) = 0.2 * \gamma_x^{rel}(t) + [V_x^{rel}(t)]^2$$

The maximum overall NIC value (NIC_{max}) shall be determined, considering only the portion of data from T=0 (start of test) until T-HRC(end) (end of contact between head and head restraint), as follows:

$$NIC_{max} = \underset{T-HRC_{(end)}}{Max} [NIC(t)]$$

4.3.2. Upper neck shear force (Upper Neck Fx) and lower neck shear force (Lower Neck Fx)

These are shear forces measured by the dummy's upper neck and lower neck load cells. If the instrumentation is configured in accordance with SAE J211, positive shear force shall indicate a head-rearwards motion. Data shall be filtered at CFC 1000, and the maximum value of the force shall be determined, considering the portion of data from T=0 until T-HRC(end) and only the positive portion of data, as follows:

$$Fx_{max} = \underset{T-HRC_{(end)}}{Max} [Fx(t)]$$

4.3.3. Upper neck axial force (Upper Neck Fz) and lower neck axial force (Lower Neck Fz)

These are axial forces (tensile and compressive loads) measured by the dummy's upper neck and lower neck load cells. If the instrumentation is configured in accordance with SAE J211, positive axial force shall be associated with pulling the head upwards. Data shall be filtered at CFC 1000, and the maximum value of the force shall be determined, considering the portion of data from T=0 until T-HRC(end) and only the positive portion of data, as follows:

$$Fz_{max} = \underset{T-HRC_{(end)}}{Max} [Fz(t)]$$

4.3.4. Upper neck lateral axial rotation moment (Upper Neck My)

This is lateral axial rotation moment measured by the dummy's upper neck load cell.

If the instrumentation is configured in accordance with SAE J211, positive lateral axial rotation moment shall indicate flexion of the head (head rotating forwards). Data shall be filtered at CFC 600. Due to the construction of the dummy, a correction shall then be made to convert the actual moment measured by the upper neck load cell into the moment about the occipital condyle (OC), as follows:

$$My^{OC}(t) = My^{Upper}(t) - DFx^{Upper}(t)$$

$D = 0.01778$

The maximum value of the moment My^{OC} shall be determined, considering the portion of data from T=0 until T-HRC(end) and both the positive and negative portions of data, as follows:

$$My^{OC}_{max} = \underset{T-HRC_{(end)}}{Max} [My^{OC}(t)]$$

4.3.5. Lower neck lateral axial rotation moment (Lower Neck My)

This is lateral axial rotation moment measured by the dummy's lower neck load cell.

If the instrumentation is configured in accordance with SAE J211, positive lateral axial rotation moment shall indicate flexion of the head (head rotating forwards). Data shall be filtered at CFC 600, and the maximum value of the moment shall be determined, considering the portion of data from T=0 until T-HRC(end) and both the positive and negative portions of data, as follows:

$$My_{max} = \underset{T-HRC_{(end)}}{Max} [My(t)]$$

Reference Point	Time (ms)	Acceleration (m/s ²)
A	0	10
B	28	94
C	60	94
D	92	0
E	4	0
F	38.5	80
G	49.5	80
H	84	0

Table 9-1 — Sled pulse corridor reference point locations.

[

Time	Slope_Upper	Time	Slope_Lower
4.2	10.8	8.4	10.8
5.3	14.2	9.5	14.2

6.3	18.0	10.5	18.0
7.4	22.3	11.6	22.3
8.4	27.0	12.6	27.0
9.5	32.2	13.7	32.2
10.5	37.8	14.7	37.8
11.6	43.7	15.8	43.7
12.6	49.8	16.8	49.8
13.7	56.0	17.9	56.0
14.7	62.2	18.9	62.2
15.8	68.4	20.0	68.4
16.8	74.3	21.0	74.3
17.9	80.0	22.1	80.0
18.9	85.2	23.1	85.2

Time	Max_Horizontal	Time	Max_Vertical
17.9	113.3	28.4	82.4
38.9	113.3	28.4	92.7

Time	1GLevel_Upper	Time	1GLevel_Lower
105.0	10.3	105.0	-10.3
147.0	10.3	147.0	-10.3

Unit: Time[ms], Acc[m/s²]

Table 9-2 Range of Each Corridor]

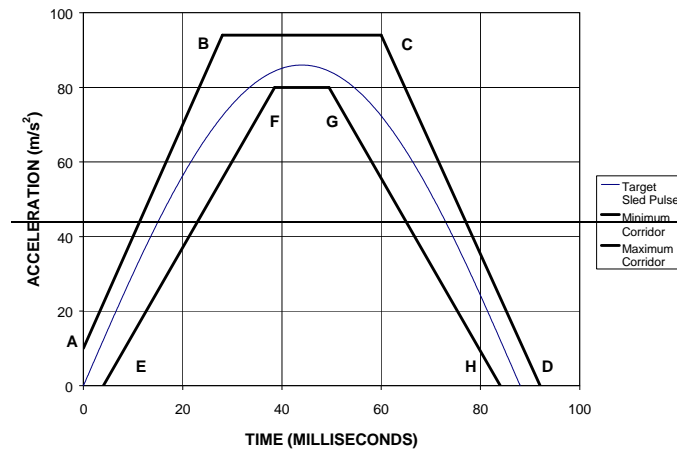

Figure 9-1 Sled pulse acceleration corridor.

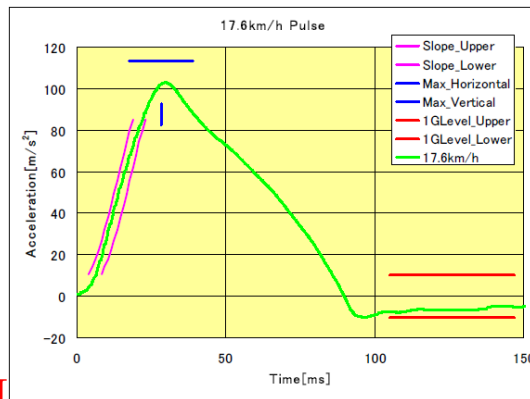

Figure 9-3 Impact Waveform and Permissible Range of Waveform

The target acceleration with time expressed in milliseconds shall meet the value in the table 9-3.

Table 9-3 Test Waveform Tolerances

		Definition	Tolerance	Unit
Velocity change	ΔV	17.6	± 0.9	km/h
Duration	ΔT	90.0	± 5.0	ms
Mean acceleration	Mean Acceleration	54.3	± 5.0	m/s ²
T=0 acceleration	AT0	0.0	± 3.0	m/s ²

]

Annex 10

NON-USE POSITION TEST PROCEDURE

1. PURPOSE

Procedures for folding or retracting head restraints in all designated seating positions equipped with head restraints, except the driver's designated seating position.

2. PROCEDURES TO TEST AUTOMATIC RETURN HEAD RESTRAINTS

Demonstrate compliance with paragraph 5.4.4.1, with the ignition "on", and using a 5th percentile female Hybrid III test dummy ^{1/} in accordance with paragraph 2.1. of this Annex, or a human surrogate in accordance with paragraph 2.2. of this Annex. Compliance is determined at a temperature of 18 to 28 °C.

2.1. 5th percentile Hybrid III Dummy

2.1.1. Position the test dummy in the seat such that the dummy's midsagittal plane is aligned within 15 mm of the seating position centreline and is parallel to a vertical plane parallel to the vehicle vertical longitudinal zero plane.

2.1.2. Hold the dummy's thighs down and push rearward on the upper torso to maximize the dummy's pelvic angle.

2.1.3. Place the legs as close as possible to 90 degrees to the thighs. Push rearward on the dummy's knees to force the pelvis into the seat so there is no gap between the pelvis and the seat back or until contact occurs between the back of the dummy's calves and the front of the seat cushion such that the angle between the dummy's thighs and legs begins to change.

2.1.4. Note the position of the head restraint. Remove the dummy from the seat. If the head restraint returns to a retracted position upon removal of the dummy, manually place it in the noted position. Determine compliance with the height requirements of paragraph 5.1.1. by using the

^{1/} The technical specifications and detailed drawings of Hybrid III dummy, corresponding to the principal dimensions of a 5th percentile female of the United States of America, and the specifications for its adjustment for this test are deposited with the Secretary General of the United Nations and may be consulted on request at the secretariat of the United Nations Economic Commission for Europe, Palais des Nations, Geneva, Switzerland.

test procedures of Annex 1.

2.2. Human surrogate

A human being who weighs between 47 and 51 kg, and who is between 140 and 150 cm tall may be used. The human surrogate is dressed in a cotton T-shirt, full length cotton trousers, and sneakers. Specified weights and heights include clothing.

- 2.2.1. Position the human in the centre of the seat with the pelvis touching the seat back and the back against the seat back.
- 2.2.2. Verify the human's midsagittal plane is vertical and within ± 15 mm of the seating position centreline.
- 2.2.3. Verify the transverse distance between the centres of the front of the knees is 160 to 170 mm. Centre the knee separation with respect to the seat centreline.
- 2.2.4. If needed, extend the legs until the feet do not contact the floor pan. The thighs are resting on the seat cushion.
- 2.2.5. If the human contacts the interior move the seat rearward until a maximum clearance of 5 mm is achieved or the seat is in the closest detent position which does not cause human contact.
- 2.2.6. Passenger foot positioning.
 - 2.2.6.1. Place feet flat on the toe board, or
 - 2.2.6.2. If the feet cannot be placed flat on the toe board, the feet are perpendicular to the lower leg, and the heel is as far forward as possible and resting on the floor pan, or
 - 2.2.6.3. If the heels do not touch the floor pan, the legs are vertical and the feet parallel to the floor pan.
- 2.2.7. Passenger arm/hand positioning.
 - 2.2.7.1. Place the human's upper arms adjacent to the torso with the arm centrelines as close to a vertical longitudinal plane as possible.
 - 2.2.7.2. Place the palms of the human in contact with the outer part of the thighs.
 - 2.2.7.3. Place the little fingers in contact with the seat cushion.

2.3. Start the vehicle engine or place the ignition in the "on" position, whichever will turn on the suppression system, and close all vehicle doors. Note the position of the head restraint. Remove the human from the seat. If the head restraint returns to a retracted position upon removal of the human, manually place it in the noted position. Determine compliance with the height requirements of paragraph 5.1.1. by using the test procedures of Annex 1.

2.4. Return the ignition switch to the "off" position.

3. 60° ROTATION EVALUATION

Procedures for the rear and front centre designated seating positions to demonstrate compliance with paragraph 5.4.4.2.

3.1. Place the head restraint in any position meeting the requirements of paragraph 5.1.1.3. or paragraph 5.1.1.5. of the regulation;

3.1.1. Mark a line on the head restraint with one end at the point of rotation. Measure the angle or range of angles of the head restraint reference line as projected onto a vertical longitudinal vehicle plane;

3.1.2. Fold or retract the head restraint to a position in which its minimum height is less than that specified in paragraph 5.1.1.3. or paragraph 5.1.1.5.;

3.1.3. Determine the minimum change in the head restraint reference line angle as projected onto a vertical longitudinal vehicle plane from the angle or range of angles measured in paragraph 3.1.1. of this Annex.

4. DISCOMFORT METRIC

Procedures for the rear and front centre designated seating positions to demonstrate compliance with paragraph 5.4.4.3. of this regulation.

4.1. The H_{LE} and S dimensions are defined in Figure 10-1. Figure 10-1 is a vertical fore-aft plane passing through the R-point (i.e. at the mid point of the designated seating position) intersecting the seat cushion, seat back and the head restraint.

4.2. Adjust the head restraint to the non-use position.

4.2.1. H_{LE} is the distance from the R-point to the lower edge of the head restraint measured along the torso line.

4.2.2. S is the maximum thickness of the head restraint (as determined within 25 mm of the head restraint lower edge) measured perpendicular to the torso line between T_H and T_S from line P.

- 4.2.3. P is a line parallel to the torso line which intersects the head restraint at T_S
- 4.2.4. T_H is the line perpendicular to the torso line and tangent to the lower edge of the head restraint.
- 4.2.5. T_S is the line parallel to and 25 mm from T_H .

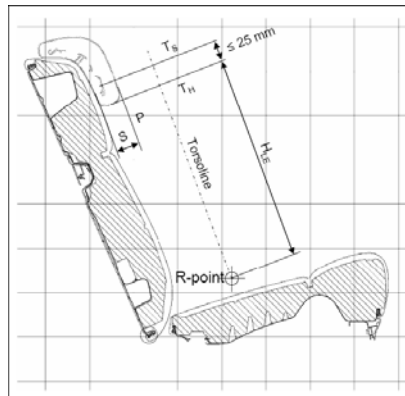

Figure 10-1

5. 10° TORSO LINE CHANGE

Procedures for the rear and front centre designated seating positions to demonstrate compliance with paragraph 5.4.4.4.

- 5.1. Place the head restraint into any position meeting the requirements of paragraph 5.1.1 of this regulation;
- 5.2. Measure the torso line angle with the three dimensional H-point machine defined in Annex 13;
- 5.3. Fold or retract the head restraint to any position in which its minimum height is less than that specified in paragraph 5.1.1. of this regulation or in which its backset is more than that specified in paragraph 5.1.5. of this regulation; and
- 5.4. Again measure the torso line angle.

Annex 11

THREE-DIMENSIONAL REFERENCE SYSTEM

1. The three dimensional reference system is defined by three orthogonal planes established by the vehicle manufacturer (see Figure 11-1) 1/
2. The vehicle measuring attitude is established by positioning the vehicle on the supporting surface such that the co ordinates of the fiducial marks correspond to the values indicated by the manufacturer.
3. The coordinates of the "R" point and the "H" point are established in relation to the fiducial marks defined by the vehicle manufacturer.
1/ The reference system corresponds to ISO standard 4130: 1978.

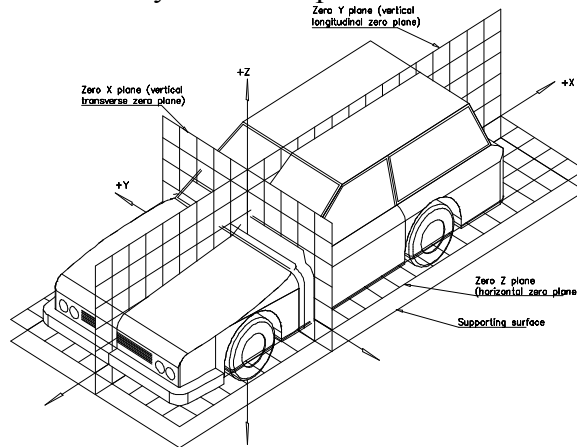

Figure - Three dimensional reference system

Figure 11-1 - Three-dimensional reference system

Annex 12PROCEDURE FOR VALIDATION OF THE H-POINT AND R-POINT
RELATIONSHIP FOR SEATING POSITIONS IN MOTOR VEHICLES

1. PURPOSE

The procedure described in this Annex is used to establish the H-point location and the actual torso angle for one or several seating positions in a motor vehicle and to verify the relationship of measured data to design specifications given by the vehicle manufacturer.

2. DEFINITIONS

For the purposes of this Annex:

2.1. "Reference data" means one or several of the following characteristics of a seating position:

2.1.1. the H- point and the R-point and their relationship,

2.1.2. the actual torso angle and the design torso angle and their relationship.

2.2. "Three-dimensional H-point machine (3-D H machine)" means the device used for the determination of H-points and actual torso angles. This device is described in Annex 13;

2.3. "Centre plane of occupant (C/LO)" means the median plane of the 3-D H machine positioned in each designated seating position; it is represented by the coordinate of the H-point on the "Y" axis. For individual seats, the centre plane of the seat coincides with the centre plane of the occupant. For other seats, the centre plane of the occupant is specified by the manufacturer;

2.4. "Three-dimensional reference system" means a system as described in Annex 11;

2.5. "Fiducial marks" are physical points (holes, surfaces, marks or indentations) on the vehicle body as defined by the manufacturer;

2.6. "Vehicle measuring attitude" means the position of the vehicle as defined by the coordinates of fiducial marks in the three-dimensional reference system.

3. PROCEDURE FOR H-POINT AND ACTUAL TORSO ANGLE
DETERMINATION

- 3.1. The vehicle is preconditioned at a temperature of $20\text{ }^{\circ}\text{C} \pm 10\text{ }^{\circ}\text{C}$ to ensure that the seat material reaches room temperature.
- 3.2. The vehicle is at the measuring attitude defined in paragraph 2.6. of this Annex.
- 3.3. The seat, if it is adjustable, is adjusted first to the rearmost normal driving position, as indicated by the vehicle manufacturer, taking into consideration only the longitudinal adjustment of the seat, excluding seat travel used for purposes other than normal driving positions. Where other modes of seat adjustment exist (vertical, angular, seat back, etc.) these will be then adjusted to the position specified by the vehicle manufacturer. For suspension seats, the vertical position is rigidly fixed corresponding to a normal driving position as specified by the manufacturer.
- 3.4. The area of the seating position contacted by the 3-D H machine is covered by a muslin cotton, of sufficient size and appropriate texture, described as a plain cotton fabric having 18.9 threads per cm^2 and weighing 0.228 kg/m^2 or knitted or non woven fabric having equivalent characteristics.

If the test is run on a seat outside the vehicle, the floor on which the seat is placed shall have the same essential characteristics (tilt angle, height difference with a seat mounting, surface texture, etc.) as the floor of the vehicle in which the seat is intended to be used.

- 3.5. Place the seat and back assembly of the 3-D H machine so that the centre plane of the occupant (C/LO) coincides with the centre plane of the 3-D H machine. At the manufacturer's request, the 3-D H machine may be moved inboard with respect to the C/LO if the 3-D H machine is located so far outboard that the seat edge will not permit levelling of the 3-D H machine.
- 3.6. Attach the foot and lower leg assemblies to the seat pan assembly, either individually or by using the T bar and lower leg assembly. A line through the "H" point sight buttons is parallel to the ground and perpendicular to the longitudinal centre plane of the seat.
- 3.7. Adjust the feet and leg positions of the 3-D H machine as follows:
 - 3.7.1. In the case of front outboard seats:
 - 3.7.1.1. Both feet and leg assemblies are moved forward in such a way that the feet take up natural positions on the floor, between the operating pedals if necessary. Where possible the left foot is located approximately the same distance to the left of the centre plane of the 3-D H machine as the right

foot is to the right. The spirit level verifying the transverse orientation of the 3-D H machine is brought to the horizontal by readjustment of the seat pan if necessary, or by adjusting the leg and foot assemblies towards the rear. The line passing through the H-point sight buttons is maintained perpendicular to the longitudinal centre plane of the seat.

3.7.1.2. If the left leg cannot be kept parallel to the right leg and the left foot cannot be supported by the structure, move the left foot until it is supported. The alignment of the sight buttons is maintained.

3.7.2. In the case of rear outboard seats:

For rear seats or auxiliary seats, the legs are located as specified by the manufacturer. If the feet then rest on parts of the floor which are at different levels, the foot which first comes into contact with the front seat shall serve as a reference and the other foot is so arranged that the spirit level giving the transverse orientation of the seat of the device indicates the horizontal.

3.7.3. In the case of other seats:

The general procedure indicated in paragraph 3.7.1. of this Annex is followed except that the feet are placed as specified by the vehicle manufacturer.

3.8. Apply lower leg and thigh weights and level the 3-D H machine.

3.9. Tilt the back pan forward against the forward stop and draw the 3-D H machine away from the seat back using the T bar. Reposition the 3-D H machine on the seat by one of the following methods:

3.9.1. If the 3-D H machine tends to slide rearward, use the following procedure. Allow the 3-D H machine to slide rearward until a forward horizontal restraining load on the T bar is no longer required i.e. until the seat pan contacts the seat back. If necessary, reposition the lower leg.

3.9.2. If the 3-D H machine does not tend to slide rearward, use the following procedure. Slide the 3-D H machine rearwards by applying a horizontal rearward load to the T bar until the seat pan contacts the seat back (see Figure 13-2 of Annex 13).

3.10. Apply a 100 ± 10 N load to the back and pan assembly of the 3-D H machine at the intersection of the hip angle quadrant and the T bar housing. The direction of load application is maintained along a line passing by the above intersection to a point just above the thigh bar housing (see Figure 13-2 of Annex 13). Then carefully return the back pan to the seat back. Care must be exercised throughout the remainder of the procedure to

prevent the 3-D H machine from sliding forward.

- 3.11. Install the right and left buttock weights and then, alternately, the eight torso weights. Maintain the 3-D H machine level.
- 3.12. Tilt the back pan forward to release the tension on the seat back. Rock the 3-D H machine from side to side through 10 degrees arc (5 degrees to each side of the vertical centre plane) for three complete cycles to release any accumulated friction between the 3-D H machine and the seat.
 - 3.12.1. During the rocking action, the T bar of the 3-D H machine may tend to diverge from the specified horizontal and vertical alignment. The T bar must therefore be restrained by applying an appropriate lateral load during the rocking motions. Care is exercised in holding the T bar and rocking the 3-D H machine to ensure that no inadvertent exterior loads are applied in a vertical or fore and aft direction.
 - 3.12.2. The feet of the 3-D H machine are not to be restrained or held during this step. If the feet change position, they should be allowed to remain in that attitude for the moment.
 - 3.12.3. Carefully return the back pan to the seat back and check the two spirit levels for zero position. If any movement of the feet has occurred during the rocking operation of the 3-D H machine, they must be repositioned as follows:
 - 3.12.4. Alternately, lift each foot off the floor the minimum necessary amount until no additional foot movement is obtained. During this lifting, the feet are to be free to rotate; and no forward or lateral loads are to be applied. When each foot is placed back in the down position, the heel is to be in contact with the structure designed for this.
 - 3.12.5. Check the lateral spirit level for zero position; if necessary, apply a lateral load to the top of the back pan sufficient to level the 3-D H machine's seat pan on the seat.
- 3.13. Holding the T bar to prevent the 3-D H machine from sliding forward on the seat cushion, proceed as follows:
 - 3.13.1. Return the back pan to the seat back;
 - 3.13.2. Alternately apply and release a horizontal rearward load, not to exceed 25 N, to the back angle bar at a height approximately at the centre of the torso weights until the hip angle quadrant indicates that a stable position has been reached after load release. Care is exercised to ensure that no exterior downward or lateral loads are applied to the 3-D H machine. If another level adjustment of the 3-D H machine is necessary, rotate the

back pan forward, re-level, and repeat the procedure from paragraph 3.12. of this Annex.

- 3.14. Take all measurements:
 - 3.14.1. The coordinates of the "H" point are measured with respect to the three dimensional reference system.
 - 3.14.2. The actual torso angle is read at the back angle quadrant of the 3-D H machine with the probe in its fully rearward position.
- 3.15. If a rerun of the installation of the 3-D H machine is desired, the seat assembly should remain unloaded for a minimum period of 30 minutes prior to the rerun. The 3-D H machine should not be left loaded on the seat assembly longer than the time required to perform the test.
- 3.16. If the seats in the same row can be regarded as similar (bench seat, identical seats, etc.) only one "H" point and one "actual torso angle" is determined for each row of seats, the 3-D H machine described in Annex 13 being seated in a place regarded as representative for the row. This place is:
 - 3.16.1. In the case of the front row, the driver's seat;
 - 3.16.2. In the case of the rear row or rows, an outer seat.

Annex 13DESCRIPTION OF THE THREE-DIMENSIONAL H-POINT MACHINE 1/
(3-D H machine)

1. BACK AND SEAT PANS

The back and seat pans are constructed of reinforced plastic and metal; they stimulate the human torso and thigh and are mechanically hinged at the "H" point. A quadrant is fastened to the probe hinged at the H-point to measure the actual torso angle. An adjustable thigh bar, attached to the seat pan, establishes the thigh centreline and serves as a baseline for the hip angle quadrant.

2. BODY AND LEG ELEMENTS

Lower leg segments are connected to the seat pan assembly at the T bar joining the knees, which is a lateral extension of the adjustable thigh bar. Quadrants are incorporated in the lower leg segments to measure knee angles. Shoe and foot assemblies are calibrated to measure the foot angle. Two spirit levels orient the device in space. Body element weights are placed at the corresponding centres of gravity to provide seat penetration equivalent to a 76 kg male. All joints of the 3-D H machine should be checked for free movement without encountering noticeable friction.

1/ For details of the construction of the 3-D H machine refer to Society of Automotive Engineers (SAE), 400 Commonwealth Drive, Warrendale, Pennsylvania 15096, United States of America (SAE J826 1995 version). The machine corresponds to that described in ISO Standard 6549: 1999.

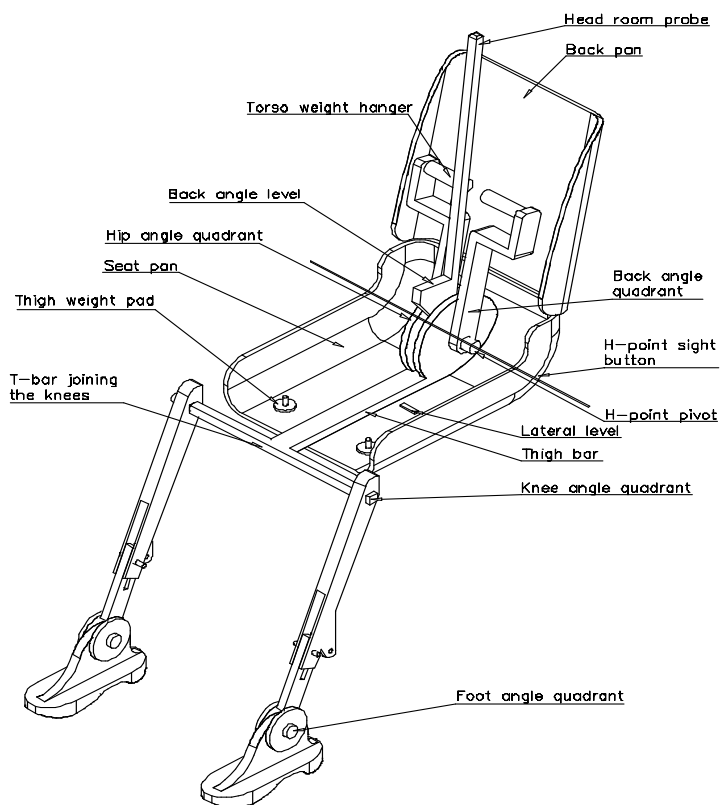

Figure 11-1 - 3-D H machine elements designation

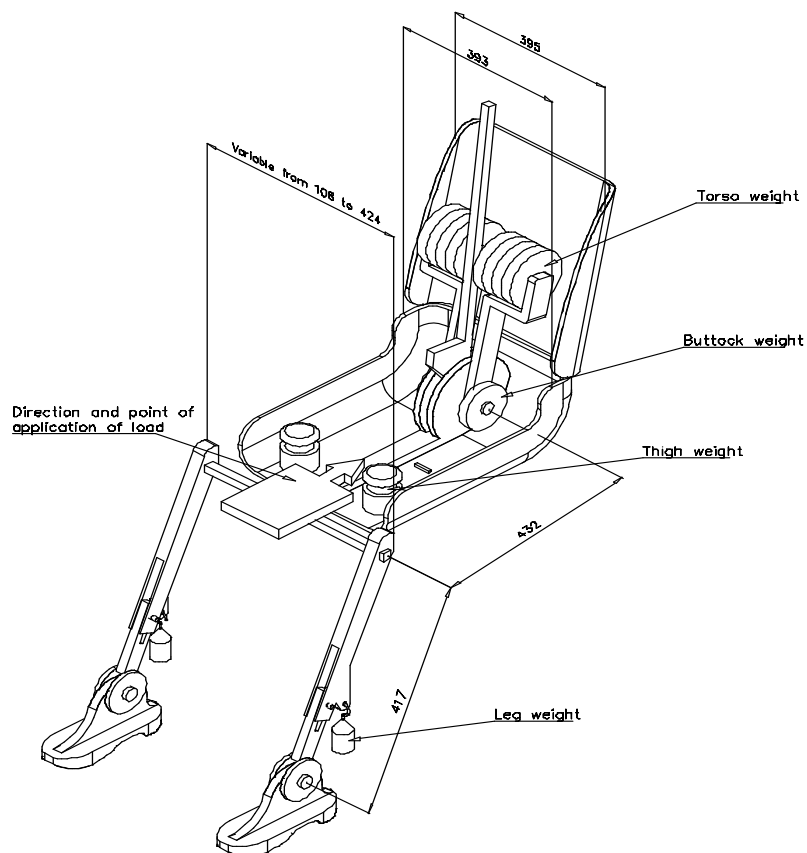

Figure 11-2 - Dimensions of the 3-D H machine elements and load distribution
(Dimensions in millimeters)
