

# Proposal how to structure the RESS safety requirements

12-14 April 2011 RESS-4-8

## Color-code:

- Red = RESS-3-7 Vibration Draft JP Proposal  
+ Further comment (in dotted box) / proposal (with yellow marker)
- Green = Remarks or amendments by the secretary
- Purple = Remarks from TÜV and BMW under § 3.7
- Blue = Remarks from France
- Turquoise = Comments and proposals from Sweden

## Contents

1. Scope .....	- 3 -
2. Definitions.....	- 3 -
2.1 Vibration.....	- 11 -
2.1.1 Rationale .....	- 11 -
3.1.2 Requirement.....	- 11 -
3.1.4 Verification .....	- 15 -
3.2 Thermal Shock and Cycling .....	- 16 -
3.2.1 Rationale .....	- 16 -
3.2.2 Requirement.....	- 16 -
3.2.5 Verification .....	- 17 -
3.1 [Dewing (temperature change).....	- 18 -
3.1.2 Rationale .....	- 18 -
3.1.3 Requirement.....	- 18 -
3.1.4 Verification].....	- 18 -
3.3 Mechanical impact .....	- 19 -
3.4.1 Mechanical Shock.....	- 19 -
3.4.2 Mechanical integrity .....	- 25 -
3.5 Fire Resistance.....	- 28 -
3.5.1 Rationale .....	- 28 -
3.5.2 Requirement.....	- 28 -
3.5.3 Verification .....	- 33 -
3.5 Fire Resistance.....	- 34 -
2.1.2 Rationale .....	- 34 -
2.1.3 Requirement.....	- 34 -
2.1.4 Verification .....	- 37 -
3.6 External Short Circuit Protection.....	- 38 -
3.6.1 Rationale .....	- 38 -
3.6.2 Requirement.....	- 38 -
3.6.3 Verification .....	- 39 -
3.7 Overcharge Protection (ISO 12405-1).....	- 40 -
3.7.1 Rationale .....	- 40 -
3.7.2 Requirement.....	- 40 -
3.1.5 Verification .....	- 41 -
3.8 Over-discharge Protection .....	- 42 -
• Rationale.....	- 42 -
• Requirement .....	- 42 -
• Verification.....	- 43 -
3.9 Over-temperature Protection .....	- 44 -

# Proposal how to structure the RESS safety requirements

12-14 April 2011 RESS-4-8

• Rationale.....	- 44 -
• Requirement .....	- 44 -
• Verification.....	- 45 -
<b>3.10 Protection against direct contact (related to R100) .....</b>	<b>- 46 -</b>
<b>3.10.1 Rationale .....</b>	<b>- 46 -</b>
<b>3.11 Emission .....</b>	<b>- 47 -</b>
<b>3.11.1 Rationale .....</b>	<b>- 47 -</b>
<b>3.11.2 Requirement .....</b>	<b>- 47 -</b>
<b>3.11.3 Verification.....</b>	<b>- 47 -</b>
<b>Annex 1: Measurement of isolation resistance .....</b>	<b>- 48 -</b>
<b>Annex 2: DIMENSIONS AND TECHNICAL DATA OF FIREBRICKS .....</b>	<b>- 52 -</b>
<b>B) Additional Requirements?.....</b>	<b>- 53 -</b>
<b>Immersion Test (RESS complete under water).....</b>	<b>- 53 -</b>
<b>[Dust].....</b>	<b>- 53 -</b>
<b>Marking .....</b>	<b>- 53 -</b>
<b>EMC .....</b>	<b>- 53 -</b>

# Proposal how to structure the RESS safety requirements

12-14 April 2011 RESS-4-8

## 1. SCOPE

The following prescriptions apply to safety requirements with respect to the Rechargeable Energy Storage Systems [RESS] of road vehicles of categories M and N, equipped with one or more traction motor(s) operated by electric power and not permanently connected to the grid.

The OEM may, when appropriate, use other methods that are deemed equivalent or more severe than those prescribed here to demonstrate that the RESS is safe and will be able to withstand the environment that the RESS will be exposed to during the life time of the vehicle. In such a case, it is the responsibility of the OEM to prove that the specified tests simulate normal use and operation as well as realistic abuse situations that may occur during the vehicle battery life and that the RESS is fully functional from a safety point of view.

### **Comment (Sweden) regarding scope and purpose of this requirements document**

This document targets electrified vehicles ranging from mild HEVs to full EVs of different types and sizes, equipped with a broad range of RESS solutions in terms chemistries, sizes and electrical specifications. Hence, there is not one, but many “normal operating conditions” and user patterns to consider and it is a challenge to cover all possibilities. One way of addressing the breadth of RESS solutions and operating conditions in order to ensure that the testing performed is relevant and meaningful is to make it the responsibility of the OEM to demonstrate that the RESS is safe and will be able to withstand the environment that the RESS will be exposed to during the life time of the vehicle it is mounted on. If the manufacturer can show documented proof that the safety requirements are fulfilled, including risk analysis (e.g FMEA or equivalent), test methodology, evaluation and acceptance criteria that are based on realistic operating and abuse situations for the vehicle type then those tests should be admissible for approval.

## 2. DEFINITIONS

2.1 “Rechargeable energy storage system (RESS)” means a system providing rechargeable electric energy based on electro-chemical processes for vehicle propulsion.

The RESS includes cells, modules and/or packs. Furthermore, the necessary ancillary subsystems for physical support thermal management, electronic control and enclosures and enclosures are included in the RESS.

“RESS-Pack” means an energy storage device that includes cells or modules normally connected with cell electronics, voltage class B circuit and over-current shut-off device including electrical interconnections, interfaces for external systems( s(e.g. cooling, voltage class B, auxiliary voltage

## Proposal how to structure the RESS safety requirements

12-14 April 2011 RESS-4-8

- 2.2 "Cell" means a single encased electrochemical unit (one positive and one negative electrode) which exhibits a voltage differential across its two terminals.
- 2.3 "Lithium ion cell" means a rechargeable electrochemical cell whose electrical energy is derived from the insertion/extraction reactions of lithium ions between the anode and the cathode.
- 2.4 "Battery" or "Battery module" means two or more cells which are electrically connected together fitted with devices necessary for use, for example, case, terminals, marking and protective devices.
- "RESS-Module" means an assembly of electrically connected cells with a mechanical supporting structure. In most cases, a serial electrical connection of cells will be applied. A module could contain further functionalities (or their parts) of the RESS as e.g. parts of the cooling system and/or first level cell electronics, but not the battery control unit. In a RESS, one or more modules could be used.
- 2.5 "Battery enclosure" means the physical housing surrounding ~~[RESS] components, particularly cells or [cell assemblies]~~ battery modules.
- 2.6 "Explosion" means very fast release of energy sufficient to cause pressure waves and/or projectiles that may cause considerable structural and/or bodily damage.
- 2.7 "Fire" means the emission of flames from a battery enclosure that may spread to the other part of the vehicle. Sparks are not flames.
- [2.8 "Cell rupture" means the mechanical failure of a cell container induced by an internal or external cause, resulting in exposure or spillage but not ejection of solid materials.] **Remark: not used for the moment in the text**
- [2.9 "Battery enclosure rupture" means openings through the battery enclosure which are created or enlarged by an event and which are sufficiently large for a 50 mm diameter sphere to contact battery system internal components (see ISO20653, IPXXA).]
- 2.10 "Working voltage" means the highest value of an electrical circuit voltage root mean square (rms), specified by the manufacturer or determined by measurement, which may occur between any conductive parts in open circuit conditions or under normal operating condition. If the electrical circuit is divided by galvanic isolation, the working voltage is defined for each divided circuit, respectively.
- 2.11 "Hazardous Voltage" means the classification of an electric component or circuit, if it's working voltage is  $> 60 \text{ V}$  ~~and  $\leq 1500 \text{ V}$~~  DC or  $> 30 \text{ V}$  ~~and  $\leq 1000 \text{ V}$~~  AC root mean square (rms).

## Proposal how to structure the RESS safety requirements

12-14 April 2011 RESS-4-8

- [2.12 Nominal voltage is the voltage given by the supplier as the recommended operating voltage of their battery system] **Remark:** not used for the moment in the text
- 2.14 “Venting” means a condition when the cell electrolyte and/or battery solvent is emitted as vapor, smoke or aerosol from a designed vent or through a sealing edge on the cell.
- 2.15 “Undefined venting” “Undesired venting” means venting or vapors external to the RESS assembly except through designated ventilation systems or openings
- 2.16 “Closed chemical process” means
- 2.17 “SOC” means available capacity in a battery pack or system expressed as a percentage of rated capacity
- 2.18 “MOSOC” means Maximum Operating State of Charge (Reference: CSDS UL 2580-2011)
- 2.19 “SC” means standard cycle consisting of a standard charge and a standard discharge load based on the rated capacity of the RESS.
- 2.20 “Thermal equilibration” means to balance the temperature throughout the RESS as required before some tests
- 2.21 “Passive thermal equilibration” is achieved by allowing the RESS to adjust to ambient temperature during a time period of X hours.
- 2.22 “Active thermal equilibration” is achieved by utilizing a thermal management system forcing the internal temperature of the DUT to the required testing temperature uniformly throughout the DUT
- 2.23 “DUT” means Device Under Test
- 2.24 “RT” means room temperature and is defined as  $25 \pm 5$  °.

### 3.0 General requirements and conditions

#### Comment (Sweden) regarding proposal to insert a section for general requirements and conditions

There are a number of procedures (e.g. test sequence and number of samples for each test, evaluation criteria, standard cycles and thermal equilibration to test temperature) that are common throughout this document. We propose that they are compiled in a common chapter.

#### 3.0.1 Test objects and test sequence

#### Comment (Sweden) regarding test samples and test sequence

The number of test objects/test needs to be defined. The work group may want to consider varying the number of required test objects depending on if the test is performed on a full RESS or on a component (module) level (e.g. more test samples for component testing).

If a test object is to be reused for subsequent testing, the test sequence must be defined as this may affect test results. Subjecting the DUT to consecutive tests is more demanding than using a new sample for each test, ref UN 38.3 T1-T5.

#### 3.0.2 Evaluation criteria and verification

#### Comment (Sweden) regarding evaluation scheme for acceptance criteria

RESS response to tests needs to be assessed by a common standard. We propose the Hazard and Severity Levels evolved from the work by EUCAR and Sandia National Labs,. These are commonly used in industry standards, for example SAE J2464 and CSDC UL2580)

RESS response to tests are evaluated against the hazard severity level scheme in Table 1.

Table 1 Classification of hazard severity levels and verification method

Hazard Severity Level	Description	Classification Criteria and Effect	Verification
0	No effect	No effect. No loss of functionality	Electrical verification. Perform SC
1	Passive protection activated	No damage or hazard; reversible loss of function. Replacement or re-setting of protective device is sufficient to restore normal functionality.	Electrical verification. Perform SC after resetting passive protection
2	Defect/damage	No hazard but damage to RESS; irreversible loss of function. Replacement or	Electrical verification.

## Proposal how to structure the RESS safety requirements

12-14 April 2011 RESS-4-8

		repair needed.	
3	Minor leakage/venting	Evidence of cell leakage or venting with RESS weight loss < 50% of electrolyte weight.	Scalar measurement (weight loss) OR Gas emissions detection.
4	Major leakage/venting	Evidence of cell leakage or venting with RESS weight loss > 50% of electrolyte weight.	Scalar measurement (weight loss) OR Gas emission detection. It should be verified that any emitted gases or electrolyte aerosols are vented through designated channels.
5	Rupture	Loss of mechanic integrity of the RESS container, resulting in release of contents. The kinetic energy of released material is not sufficient to cause physical damage external to the RESS.	Ocular inspection
6	Fire or flame	Ignition and sustained combustion of flammable gas or liquid (approx more than 1 second). Sparks are not flames.	Ocular inspection
7	Explosion	Very fast release of energy sufficient to cause pressure waves and/or projectiles that may cause considerable structural and/or bodily damage, depending on the size of the RESS. The kinetic energy of flying debris from the RESS may be sufficient to cause damage as well.	Ocular inspection

The normal observation period, unless otherwise stated explicitly, after tests should be minimum 6 h or until the DUT shows signs of thermal stabilization.

The explosion and rupture criterion is verified by ocular inspection. Indicators of rupture or explosion include, but are not limited to: sudden increase in flame intensity or size, emission of projectiles, loud noise.

For RESS working at high voltage, the isolation resistances measured at the end of the test shall maintain high voltage to ground isolation no less than 100  $\Omega$ /Volt.] In addition a requirement on impedance/capacitance against chassis is needed. The isolation resistance shall be measured according to Annex 1.

# Proposal how to structure the RESS safety requirements

12-14 April 2011 RESS-4-8

### 3.0.3 Classification of tests and acceptance criteria

Criteria and test methods to evaluate RESS safety is divided into two categories:

1. Normal operating conditions
2. Out of normal operating conditions

The first category characterizes tests that are designed to verify safety in various situations that may occur as part of normal driving situations, such as vibration and temperature cycling. While the second category of tests abuse situations that are not part of normal vehicle operation, such as crash or fire. Table 2 lists the tests under the respective category.

**Table 2** Test categories and acceptance criteria

Category	Tests	Acceptance criteria
<b>Normal operating conditions</b>	Vibration	<ol style="list-style-type: none"> <li>1. Hazard severity level 2</li> <li>2. Voltage to ground isolation resistance <math>\geq 100\Omega/V</math></li> <li>3. Impedance/capacitance against chassis <math>\geq X</math></li> </ol>
	Thermal shock and cycling	
	Overtemperature protection	
	Protection against direct contact	
	Emissions	
<b>Out of normal conditions</b>	Mechanical impact - shock	<ol style="list-style-type: none"> <li>1. Hazard severity level 4</li> <li>2. Any emitted gases or electrolyte aerosols are vented through designated channels.</li> <li>3. Voltage to ground isolation resistance <math>\geq 100\Omega/V</math></li> <li>4. Impedance/capacitance against chassis <math>\geq X</math></li> </ol>
	Mechanical impact – integrity	
	External short circuit	
	Fire	
	Overcharge protection	
	Overdischarge protection	

#### **Comment (Sweden) Regarding need for classifying tests**

It simplifies assignment of adequate acceptance criteria if the purpose of the test is clearly defined. We recommend using the term to characterize any event involving a failure (for example a short circuit or loss of current limitation at charge/discharge) or an extraordinary situation (such as crash or fire).

Table 2 is a suggestion of a possible categorization of tests. Final classification needs to be discussed, based on the intended severity level of the tests.

### 3.0.4 Standard cycle

#### 3.0.4.1 Rationale

A standard charge/discharge cycle is performed in order to verify the functionality of the RESS after reliability/safety test.



# Proposal how to structure the RESS safety requirements

12-14 April 2011 RESS-4-8

## 3.0.4.2 Requirements

It is recommended that testing starts with SC in order to verify DUT functionality and as a reference for acceptance for tests that require post-test SC.

A standard cycle is required after tests 3.1 Vibration, 3.2 Thermal shock and cycling, 3.6 Short Circuit protection, 3.7 Overcharge protection, 3.8 Overdischarge protection and 3.9 Over temperature protection to verify safe behavior of RESS.

When test prescribes OCV and isolation resistance measurements, these shall be performed prior to SC.

## 3.0.4.3 Conditions

The standard cycle is performed at RT ( $25 \pm 5$  °C). If needed, the DUT shall be acclimatized at the test temperature prior to performing the SC.

### Standard discharge (SDCH):

Discharge rate: 1C

Discharge limit (end voltage): specified by battery manufacturer

Rest period after discharge: 30 min or thermal equilibrium at test temperature

### Standard charge (SCH):

Charge procedure including termination criteria as defined by battery manufacturer. If not specified, charge with C/3 current.

Rest after charge: 1 h or thermal equilibrium at test temperature

Note: C rate is the marked capacity rating of the cell/battery.  $nC$  is the current rate equal to  $n$  times the 1 h discharge capacity expressed in Amperes.

### **Comment (Sweden): Definition of Standard Cycle (SC)**

If acceptance criteria in this document are to be based on performance of standard cycle after test, then the "standard cycle" must be defined. Since the purpose of the standard cycle is to verify that the RESS can does not exhibit dangerous behavior after being exposed to abusive conditions, the requirement on the load of the standard cycle is that it is reasonable and sufficient to trigger a hazardous response, in case of abnormal conditions in the RESS. 1C discharge current should be reasonable for Li-ion and NiMH technologies. Acceptable charge current levels depend on the battery technology and hence the manufacturer's recommendation should be used when applicable. A typical range for charge current is C/3 (ISO 12405-2) and 1C (ISO 12405-1).

# Proposal how to structure the RESS safety requirements

12-14 April 2011 RESS-4-8

## 3.0.4 Thermal equilibration at test temperature

### Comment (Sweden) regarding test temperature and importance of temperature equilibration

The temperature of the DUT and the ambient are fundamental test parameters that define the test conditions and that may affect test results. It is important to allow sufficient time for temperature equilibration for reasons of reproducibility and repeatability.

Standard passive equilibration time is 12 h (ISO 12405 and UN38.3). When copying tests from existing or emerging battery industry standards, we suggest that the test methodology allows for harmonization with the source standard in order to minimize risk of repeated testing.

#### 3.0.4.1 Rationale

When a test is prescribed to be performed at a specified temperature, it is important to allow sufficient time for the entire DUT to reach a homogeneous temperature.

#### 3.0.4.2 Requirements

Thermal equilibrium is reached if the deviations between test temperature and temperature of all cell temperature measuring points in the DUT are lower than  $\pm 5K$

#### 3.0.4.3 Conditions

Thermal equilibrium can be attained by passive or active thermal equilibration. In order to simulate normal operating conditions, active heating/cooling, using the RESS thermal management system is preferred. Passive equilibration is attained by keeping the DUT a minimum of **x h** at the test temperature or until thermal equilibrium of the RESS is demonstrated.

Temperatures shall be measured at a sufficient number of locations to assure that temperature extremes of the battery under test are recorded. If a battery system is tested, the minimum number of temperature measurement locations shall be 5. Temperature measuring points shall be specified by the manufacturer, as the locations that most closely reflect the electrolyte temperature. If not specified, the temperature sensor shall be placed at the center of the largest surface of a cell that is an integral part of a monobloc.

### Comment (Sweden) regarding standard conditions for testing

As a rule, abuse tests should be performed at the maximum operating SOC and operating temperature of the RESS, as this defines the margin to failure.

# Proposal how to structure the RESS safety requirements

12-14 April 2011 RESS-4-8

## Technical Requirements

### A) Priority Requirements

#### 2.1 Vibration

##### 2.1.1 Rationale

~~Simulates a vibration environment which a [battery system] will likely experience during the lifetime of the vehicle. Vibration of the vehicle body is random vibration induced by rough-road-driving as well as internal vibration of the power train. This test checks the [RESS] for specific malfunctions and breakage caused by this vibration.~~

~~The purpose of this test is to verify the safety performance of a the [RESS] (or a sub-assembly of [RESS]) under a vibration environment which the RESS will likely experience during the lifetime of the vehicle.~~

UN 38.3 vibration profile is not representative of [battery system] that will likely experience during the lifetime of the vehicle. Random vibration according to ISO 16750-3 (IEC 68-2-4) is better relevant. So, we propose to keep the test taken from ISO 12405.

#### **Comment (Sweden) regarding mode of vibration**

We agree with the comment from France that the vibration mode in ISO 16750-3 (IEC 68-2-4) is more representative of vehicle condition than UN38.3.

If the manufacturer can show that another mode of vibration is more relevant for normal usage of a specific vehicle type, then testing against that vibration profile should be allowed..

#### 3.1.2 Requirement

##### 3.1.2.1 Conditions

The following test can be conducted with the complete [RESS] or, at the discretion of the manufacturer, with [module(s) of the RESS] the battery module(s) and related subsystems (module-based test).

If the manufacturer chose the module-based test, the manufacturer shall demonstrate such test result can reasonably represent the performance of the complete RESS with respect to the safety performance under similar condition.

For the purpose of this test, the devices of the [RESS] subject to the vibration test shall be referred to as DUT (Device Under Test). DUT shall be firmly secured to the platform of the vibration machine in such a manner as to faithfully transmit the vibration. If certain electronic management unit for [RESS] is not integrated, such control unit may not be installed on DUT.

~~[If tests are performed on [module basis], evidence shall be provided that the results are representative for [RESS].]~~

~~Due to the big mass of this [RESS] the maximum test frequency is limited to 200 Hz, but the vibration test shall be performed in sequence in all three spatial directions.~~

# Proposal how to structure the RESS safety requirements

12-14 April 2011 RESS-4-8

Adjust the State of Charge (SOC) with discharge to [50 %] before starting the vibration test profile.

The DUT should have an internal temperature of  $25^{\circ}\text{C} \pm 5^{\circ}\text{C}$  throughout the RESS prior to the initiation of the test.

## 3.1.2.2. State of charge-Preconditioning of DUT [RESS]

The test shall be performed according

- to [IEC 60068-2-64], see Tables 1 to 4 or
- to a test profile determined by the vehicle manufacturer, verified to the vehicle application and agreed by the Technical Service.

The [RESS] shall be mounted on a shaker test bench in a way that the load application is equivalent to the mounting in the vehicle.

The [module(s)] shall be mounted on a shaker test bench in a way that the load application is equivalent to each mounting position (tolerance to be defined) in the [RESS].

## 2.1. Installation of [RESS] for the test

For the purpose of this, the devices of [RESS] (or [sub-assembly(ies)] of [RESS]) subject to the vibration test shall be referred to as DUT (Device Under Test). DUT shall be firmly secured to the platform of the vibration machine in such a manner as to faithfully transmit the vibration. If certain electronic management unit for [RESS] is not integrated, such control unit may not be installed on DUT.

With only one test device the vibration test shall be performed in a sequence of all three spatial directions

- vertical direction (Z),
- transverse direction (Y) and
- longitudinal direction (X).

a) [The mechanical stresses acting on the [RESS] are specified by a stochastic acceleration – time function with test duration per spatial direction of 21 h. The test duration per spatial direction can be reduced to 15 h if the test procedure is performed with two identical [RESS] or to 12 h if the test procedure is performed with three identical [RESS], respectively.]

b) [The test duration per spatial direction is 12 h.]

For longitudinal direction (X) see table 1, for transverse direction (Y) see table 2 or 3 and vertical direction (Z) see table 4.

[If the [RESS] is designed for a vehicle mounting position below the vehicle passenger compartment, then the reduced spectrum PSD<sub>horizontal transverse\_Y Passenger\_compartment\_bottom</sub> according to Table 3 shall be used.]

# Proposal how to structure the RESS safety requirements

12-14 April 2011 RESS-4-8

Table 1

Values for PSD\_horizontal\_longitudinal\_X

Frequency [Hz]	PSD [g <sup>2</sup> /Hz]	PSD [(m/s <sup>2</sup> ) <sup>2</sup> /Hz]
5	0,0125	1,20
10	0,03	2,89
20	0,03	2,89
200	0,00025	0,02
RMS	0,96 g	9,42 m/s <sup>2</sup>

Table 2 — Values for PSD\_horizontal\_transvers\_Y

Frequency [Hz]	PSD [g <sup>2</sup> /Hz]	PSD [(m/s <sup>2</sup> ) <sup>2</sup> /Hz]
5	0,04	3,85
20	0,04	3,85
200	0,0008	0,08
RMS	1,23 g	12,07 m/s <sup>2</sup>

Table 3 — Values for PSD\_horizontal\_transvers\_Y<sub>Passenger\_compartment\_bottom</sub>

Frequency [Hz]	PSD [g <sup>2</sup> /Hz]	PSD [(m/s <sup>2</sup> ) <sup>2</sup> /Hz]
5	0,01	0,96
10	0,015	1,44
20	0,015	1,44
50	0,01	0,96
200	0,0004	0,04
RMS	0,95 g	9,32 m/s <sup>2</sup>

Table 4 — Values for PSD\_vertical\_Z

Frequency [Hz]	PSD [g <sup>2</sup> /Hz]	PSD [(m/s <sup>2</sup> ) <sup>2</sup> /Hz]
5	0,05	4,81
10	0,06	5,77
20	0,06	5,77
200	0,0008	0,08
RMS	1,44 g	14,13 m/s <sup>2</sup>

Figure 5 shows the interpolation between the data-points of tables 1 to 4.

Figure 5 — PSD spectra for sprung masses (masses mounted on vehicle body)

# Proposal how to structure the RESS safety requirements

12-14 April 2011 RESS-4-8

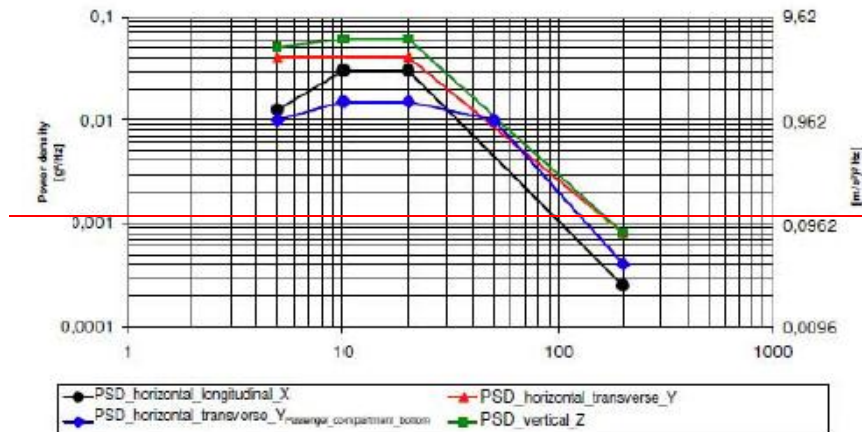

The following control parameters shall be ensured:

- Delta frequency  $1,25 \pm 0,25$  Hz
- Inner range of tolerance  $\pm 3$  dB (warning level)
- Outer range of tolerance  $\pm 6$  dB (shut-down level)

### 3.1.2.4. Records

Open circuit voltage of DUT shall be measured prior to initiation of vibration and after the vibration test.

Isolation measurement shall be done in accordance with annex 1-ISO 6469-1:2009, Section 6.1.3; or according to 3.1.3 or equivalent prior to initiation of vibration and after the vibration test.

After the test a SC cycle should be performed.

### 3.1.3.52 Acceptance criteria based on [RESS]

During the test, including [1] h after the test, the [RESS battery system] shall exhibit no evidence of

- undefined venting
- battery enclosure rupture
- fire
- explosion.
- electrolyte leakage

The charge and discharge function shall be functional.

For [RESS] using high voltage the isolation resistance measured at the end of the test shall maintain high voltage to ground isolation no less than 100  $\Omega$ /Volt.

Remark: In R 100, if high voltage DC and AC buses are galvanically connected, the isolation resistance shall be not less than 500  $\Omega$ /Volt. If the RESS is dedicated to a vehicle where there is no galvanical connection in between DC and AC high voltage buses, the isolation resistance cannot be less than 100  $\Omega$ /Volt, otherwise it shall be 500  $\Omega$ /Volt.

This comment has to be included in all paragraphs concerned.

## Proposal how to structure the RESS safety requirements

12-14 April 2011 RESS-4-8

### ~~3.1.2.3~~ ~~Acceptance criteria based on [modules]~~

~~During the test, including [1] h after the test, the [battery system] shall exhibit no evidence~~

- ~~a) of undefined visible venting~~
- ~~b) battery enclosure rupture (no degradation of protection degree)~~
- ~~c) fire~~
- ~~d) explosion.~~
- ~~e) electrolyte leakage~~

~~During the test, the [RESS] (or the sub-assembly of RESS) shall exhibit no evidence of battery enclosure rupture, fire or explosion,~~

~~For [RESS] using high voltage the isolation resistance measured at the end of the test shall maintain no degradation of high voltage to ground isolation as defined by the battery manufacturer.~~

~~and shall maintain high voltage to ground isolation no less than 100  $\Omega$ /volt. Post-test open circuit voltage shall be no less than 90% of the pre-test open circuit voltage.~~

### **3.1.4 Verification**

~~The evidence of battery enclosure rupture, fire or explosion a) to ed) of 3.1.2.2 & 3.1.2.3 shall be checked by visual inspection.~~

~~The isolation resistance shall be measured according to Annex 1.~~

# Proposal how to structure the RESS safety requirements

12-14 April 2011 RESS-4-8

## 3.2 Thermal Shock and Cycling

### 3.2.1 Rationale

Thermal shock cycling is performed to determine the resistance of the [RESS] to sudden changes in temperature. The [RESS] undergo a specified number of temperature cycles, which start at Room Temperature (RT) followed by high and low temperature cycling. It simulates a rapid environmental temperature change which a [battery system] will likely experience during its life.

<JASIC Comment>

All lithium-ion cells and batteries must satisfy the T2 test of UN Manuals of Tests and Criteria, Section 38.3, which requires thermal cycling between -40°C and +75°C (+72°C from next amendment). In order to reduce the administrative burden and duplicated test, procedure to utilize the results obtained from UN T3 tests should be considered.

### 3.2.2 Requirement

#### 3.2.3 Conditions

The conditions should be the same as for UN 38.3 in order to avoid duplicate testing but a SC should be performed after the temperature exposure.

~~The state of charge (SOC) of [RESS] DUT shall be [at least 50 % or more] the maximum which is possible during normal vehicle operation.~~

~~[RESS] shall be stored for at least six hours at a test temperature equal to at a minimum of 70°C, followed by storage for at least six hours [twelve] at a test temperature equal at to or less than -38°C. The maximum time interval between test temperature extremes is 30 minutes. This procedure is to be repeated at least 5 times, after which the [RESS] shall be stored for 24 hours at ambient temperature (20 ± 5 °C).~~

~~Remark: Depending of the RESS or pack dimensions, six hours is not sufficient to reach the heart of the RESS or the battery pack. We propose to extend to 12 hours.~~

#### ~~2.2. State of charge of~~

~~Direct after Thermal Shock and Cycling a SC standard charging has to be conducted if not inhibited by the [RESS]].~~

#### ~~3.1. Records~~

~~Open circuit voltage of DUT shall be measured prior to initiation of thermal Shock and Cycling and after the vibration thermal Shock and Cycling test. Isolation measurement shall be done in accordance with annex1 ISO 6469-1, Section 6.1.3 or according to 3.2.3 ; or equivalent prior to initiation of thermal Shock and Cycling vibration and after the vibration test.~~

#### ~~3.2.2.2 Acceptance criteria~~



## Proposal how to structure the RESS safety requirements

12-14 April 2011 RESS-4-8

~~During the test, including 1 h after the test, the [battery system] shall exhibit no evidence of~~

- ~~— a) undefined visible venting~~
- ~~— b) battery enclosure rupture (no degradation of protection degree)~~
- ~~— c) fire~~
- ~~— d) explosion~~
- ~~— e) electrolyte leakage.~~

~~=> OICA proposal based on RESS level~~

~~For this test, IPXXA is not sufficient taking into account testing conditions. IPXXB should be required?~~

~~For [RESS] using high voltage the isolation resistance measured at the end of the test shall maintain high voltage to ground isolation no less than 100  $\Omega$ /Volt.]~~

### ~~3.2.5 Verification~~

~~a) to d) of 3.1.2.2 shall be checked by visual inspection.~~

~~The isolation resistance shall be measured according to Annex 1~~

## ~~3.1 [Dewing (temperature change)]~~

### ~~3.1.2 Rationale~~

<JASIC Comment>

Specific test and requirement for dewing is NOT necessary for the RESS regulation.

*Justification:*

The suggested testing under temperature/humidity environment may cause the following phenomena:

- a) Reduction of isolation resistance of high voltage circuit.
- b) Weak short circuit current between the terminals.

The phenomena mentioned above have already covered by existing regulation or would not cause any critical situation.

a) Isolation resistance is already required by ECE R100 that includes the protection against electric shock even under failure mode.

b) The electrical path caused by the dew condensation will disappear in a relatively short period by the electrolyses or vaporization of the water and it will not be sufficient to cause a fire.

### ~~3.1.3 Requirement~~

#### ~~3.3.2.1 Conditions~~

#### ~~3.3.2.2 Acceptance criteria~~

### ~~3.1.4 Verification]~~

# Proposal how to structure the RESS safety requirements

12-14 April 2011 RESS-4-8

## 3.3 Mechanical impact

### Remark from Korea:

#### §3. 4 Mechanical Impacts

The proposal suggests that the RESS be subject to pre-described acceleration

If this test is carried out, the RESS shall be on the sled. In that case, it is not known what will happen to the RESS. Of course, the manufacturer may know what will happen based on his experience. However, there is a slim chance of fire or explosion. Thus it may be dangerous to carry out this sled test in the confined area.

A drop test in an open space, equivalent to the pre-described acceleration, should be considered as an alternative or replacement.

<JASIC Comment>

The equivalency of such test procedure should be confirmed. There are some concerns about the repeatability and reproducibility of the test procedure due to the environmental conditions (temperature, wind, etc.) and characteristics of the ground surface.

### 3.4.1 Mechanical Shock

#### 3.4.1.1 Rationale

Simulates inertial loads which may occur during vehicle crash situation to [RESS].

#### 3.4.1.2 Requirement

**Comment (Sweden) regarding performing tests on RESS under electrical load**  
As real life vehicle collisions may occur while electric vehicles are driving, the need of exposing the RESS to an electric load (analogous to driving the vehicle at the test speed of ECE-R 94) should be discussed during next RESS meeting.

#### 3.4.1.3 Conditions

For the longitudinal and lateral vehicle direction, one of the conditions described in 3.4.1.2.1.1 or 3.4.1.2.1.2 shall be applied.

The RESS shall be set at Maximum Operating State of Charge (MOSOC) as recommended by the manufacturer

#### 3.4.1.3.1 Vehicle based test

[RESS] installed in a vehicle of category [M1, M2, N1 and N2] that undergoes a vehicle crash test according to ECE-R12 Annex 3 or ECE-R 94 Annex 3 shall meet the acceptance criteria under 3.4.1.2.2.

This test is equivalent to the test conditions described in table 5 in 3.4.1.2.1.2.

**Comment (Sweden) regarding the equivalence of the test conditions with those described in Table 5**

Justification should be presented to the RESS group that the acceleration levels of table 5 is indeed equivalent to a crash test according to ECE-R12 and ECE-R94 with a modern vehicle, before the above statement can be incorporated into this document

# Proposal how to structure the RESS safety requirements

12-14 April 2011 RESS-4-8

[RESS] installed in a vehicle of category [M1, M2, N1 and N2] that undergoes a vehicle crash test according to ECE-R95 Annex 4 shall meet the acceptance criteria under 3.4.1.2.2.

This test is equivalent to the test conditions described in table 6 in 3.4.1.2.1.2.

## Comment (Sweden) regarding the equivalence of the test conditions with those described in Table 6

Justification should be provided to the RESS group that the acceleration levels of table 6 is indeed equivalent to a crash test according to ECE-R95 with a modern vehicle, before the above statement can be incorporated into this document.

The approval of the [RESS] tested under this condition is limited to the installation in the specific vehicle type.

### 3.4.1.3.2 Component based test

[A complete [RESS] is to be tested for this condition. However, if conducting this test on a [RESS] is deemed inappropriate due to size or weight, this test may be conducted utilizing subsystem(s) including respective battery module(s), provided that all portions of the battery module(s) of the RESS are evaluated. If tests are performed on [pack-subsystem basis], evidence shall be provided that the results are representative for [RESS].]

#### [Pack(s)] have to be identified:

- For which vehicle category they are designed
- For which installation direction they are designed

<JASIC Comment>

If the component approval scheme can be established, the administrative provisions to correlate the component approval and the vehicle system approval should be prescribed in the general part of the regulation.

~~Adjust the State of Charge (SOC) to a minimum 50% before starting the impact test profile.~~

The [RESS] shall be at any state of charge, which allows the normal operation of the power train as recommended by the manufacturer.

The complete [RESS or pack(s)] shall be applied to the shock levels described in Table 5 and 6 in both positive and negative directions.

<JASIC Comment>

Reason to adjust the Soc at 50% or more should be explained.

R12/R94/R95 prescribe as below;

*"The RESS shall be at any state of charge, which allows the normal operation of the power train as recommended by the manufacturer."*

For every of the 4 evaluation conditions, a separate [RESS or subsystem(s) pack(s)] can be used. The [RESS or subsystem(s) pack(s)] shall be connected to the test fixture only by the intended mounting methods.

# Proposal how to structure the RESS safety requirements

12-14 April 2011 RESS-4-8

In order to determine potential for fire hazard an evaluation for potential flammable concentrations of vapors shall be included by use of a minimum of two continuous spark sources located near anticipated sources of vapour such as vent opening or at the vent duct. The continuous spark sources are to provide at least two sparks per second with sufficient energy to ignite natural gas. (Reference to CSDS UL 2580-2011)

## Comment (Sweden) regarding M1 and N1 acceleration levels in Table 5

In their work in the European FIMCAR project the German group Verband der Automobilindustrie (VDA) have presented crash simulations (analogous to ECE R94) on Volkswagen, Mercedes E-class and Smart. Those acceleration levels indicate that the proposed acceleration pulse for M1 and N1 in Table 5 is exceeded by more than 50-100% in a full scale R94 vehicle crash test.

Table 5 – Shock levels in direction of travel

	Acceleration
[RESS] fitted vehicles of categories M1 and N1	20g
[RESS] fitted vehicles of categories M2 and N2	10g
[RESS] fitted vehicles of categories M3 and N3	6.6g

Table 6 – Shock levels horizontally perpendicular to the direction of travel

	Acceleration
[RESS] fitted vehicles of categories M1 and N1	8g
[RESS] fitted vehicles of categories M2 and N2	5g
[RESS] fitted vehicles of categories M3 and N3	5g

The characteristic shock curve shall meet one of the following two alternatives:

- a) The test pulse shall circumscribe the minimum shock pulse described in diagram 1. The pulse shall start between 0ms and 20ms; the end of the pulse shall be between 100ms and 120ms. The duration of the shock level shall be at least 15ms.

# Proposal how to structure the RESS safety requirements

12-14 April 2011 RESS-4-8

Diagram 1 – minimum shock pulse

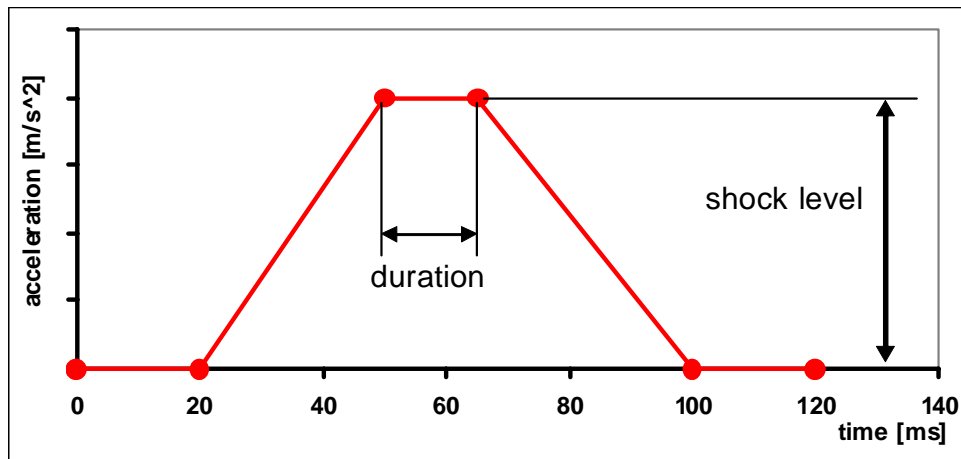

## Remark:

Frontal impact: the R 17 corridor should be incorporated in the diagram 1 (upper limit). As it is said in the test protocol § 3.4 in RESS 3-3, the test undergoes by the device can be performed via the R94 on the vehicle. So at least, the device pulse has to be equivalent to the vehicle pulse. The R17 corridor is a frontal impact R12 simulation in order to validate seat entities. The same philosophy is applied for example to the CRS in R44 with a stronger requirement (fixed rise time).

## Comment (Sweden) regarding the acceleration pulse found in R17 and R44

The upper limit of the acceleration pulse found in R17 and R44 is exceeded in the R94 crash simulations presented by VDA in the FIMCAR project. Modern vehicles represents higher structural stiffness and consequently also higher acceleration peaks than the vehicles on which the acceleration pulse corridor in R17 where designed for. The European Commission has asked for modifications of this pulse to better represent modern vehicles:

*“Commission proposed that the elements which shall be taken onboard, are as follows:  
(---)*

- *Improve the frontal crash pulse, whilst maintaining the appropriate speed of 50 km/h (...) to reflect modern vehicles under full overlap crash conditions (...);*

*(---)”*

(Reference: EUROPEAN COMMISSION ENTERPRISE AND INDUSTRY DIRECTORATE-GENERAL; “Industrial Innovation and Mobility Industries **Automotive industry**”; document D5/PB D(2011) – 252967; Brussels, 02 March 2011)

So, we think the half sinus proposed does not totally cover the need and we think the R17 corridor is more representative and relevant solution for this RESS test. Therefore, a half sinus included in the R17 corridor would be also acceptable.

# Proposal how to structure the RESS safety requirements

12-14 April 2011 RESS-4-8

Lateral impact: We propose to use the same pulse taken from R 17 with a lower test levels and a lower duration. At this time, we need more time to define exactly the signals characteristics.

- b) The test pulse shall describe a half sinus with duration of 15ms between 10% and 90% of the shock level.

Diagram 2 – sinus shock pulse

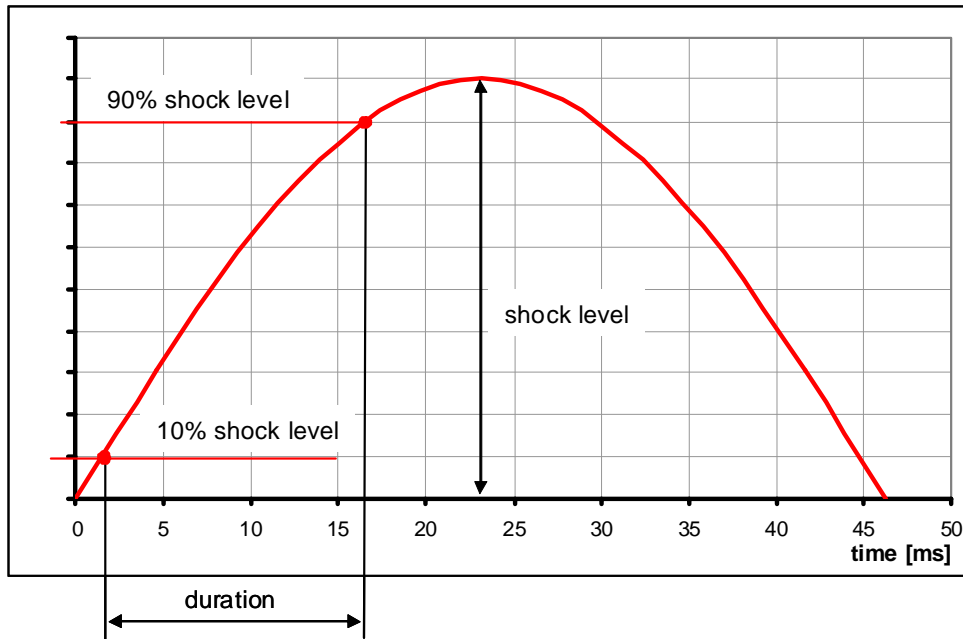

**Comment (Sweden) regarding acceleration pulses a) and b)>**  
Acceleration pulses a) and b) do not represent acceleration pulses equivalent to acceleration pulses generated in a R94 crash test with modern vehicle

<JASIC Comment>  
Pulse a) and b) are not considered as equivalent and pulse b) will be difficult to achieve at lower shock level.

### 3.1. Records

Open circuit voltage of DUT shall be measured prior to initiation of impact test .  
Isolation measurement shall be done in accordance with annex1 ISO 6469-1, Se; or equivalent prior to initiation of impact test. ]

#### 3.4.1.2.2 — Acceptance criteria

During the test, including 16 h after the test, the [RESS or pack(s)] shall exhibit no evidence of

- a) undefined visible venting
- b1) [RESS] enclosure rupture (protection degree not less than IPXXB)
- b2) [Pack(s)] enclosure ruptures (no degradation of protection degree against direct contact)
- c) fire
- d) explosion.

# Proposal how to structure the RESS safety requirements

12-14 April 2011 RESS-4-8

~~e) electrolyte leakage?~~

~~The [RESS or pack(s)] shall be retained at its mounting locations and components shall remain inside its boundaries.~~

<JASIC Comment>

The observation period should be based on a uniform philosophy throughout this regulation.

“Undefined visible venting” is not defined and would not be appropriate as a minimum safety requirement.

“Battery enclosure rupture” is difficult to assess in the vehicle test without removing the battery from the vehicle while the battery may be damaged during the removal. R12/R94/R95 requires protection against electrical shock and therefore if the vehicle test is chosen, battery enclosure rupture should not be required.

The requirement for the RESS retention can not be properly assessed in the component based test, while in the vehicle test, R12/R94/R95 have the same requirement.

For the vehicles out of scope of R12/R94/R95, certain provisions to ensure the proper installation of RESS should be established.

For [RESS] using high voltage the isolation resistance measured at the end of the test shall maintain high voltage to ground isolation no less than 100  $\Omega$ /Volt.

### ~~3.4.1.3 Verification Method~~

~~The evidence of fire or explosion a) to d) of 3.4.1.2.2 shall be checked by visual inspection.~~



# Proposal how to structure the RESS safety requirements

12-14 April 2011 RESS-4-8

## 3.4.2 Mechanical integrity

### 3.3.2.1 Rationale

Simulates contact loads which may occur during vehicle crash situation to [RESS].

### 3.4.2.2 Requirement

~~This test is not applied to the RESS intended to be use at a position higher than [800 mm] from the ground when measured at the bottom surface of the RESS or at a position protected by the vehicle body structure.~~

<JASIC Comment>

This test should only be required if the RESS is to be installed in the location where the direct contact load from external object is likely happens.

800 mm is the top height of MDB used for R95 test.

### 3.4.2.3 Conditions

The test applies only to [RESS] intended to be installed in vehicles of category M1 and N1

One of the conditions described in 3.4.2.2.1.1 or 3.4.2.2.1.2 shall be applied.

<JASIC Comment>

There is no reason to exclude larger vehicles from this requirement except when installed as above.

For the longitudinal and lateral vehicle direction, one of the conditions described in 3.4.2.2.1.1 or 3.4.2.2.1.2 shall be applied for vehicles of category M1 and N1.

The RESS shall be set at Maximum Operating State of Charge (MOSOC) as recommended by the manufacturer.

#### 3.4.2.2.1.1 Vehicle based test

[RESS] installed in a vehicle that undergoes a vehicle crash test according to ECE-R12 Annex 3 or ECE-R 94 Annex 3 shall meet the acceptance criteria under 3.4.2.2.2.

~~Optionally, test described under 3.4.2.2.1.2 can be conducted with the mechanical load according to ECE-R12 Annex 3 or ECE-R94 Annex 3. The mechanical load shall be determined by the vehicle manufacturer using test or simulation data and agreed by the Technical Service.~~

[RESS] installed in a vehicle that undergoes a vehicle crash test according to ECE-R95 Annex 4 shall meet the acceptance criteria under 3.4.2.2.2.

~~Optionally, test described under 3.4.2.2.1.2 can be conducted with the mechanical load according to ECE-R95 Annex 4. The mechanical load shall be determined by the vehicle manufacturer using test or simulation data and agreed by the Technical Service.~~

# Proposal how to structure the RESS safety requirements

12-14 April 2011 RESS-4-8

The approval of the [RESS] tested under this condition is limited to the installation in the specific vehicle type.

## 3.4.2.2.1.2 Component based test

Adjust the State of Charge (SOC) to a minimum of 50 % before starting the mechanical integrity test profile.

The [RESS] shall be at any state of charge, which allows the normal operation of the power train as recommended by the manufacturer.

<JASIC Comment>

Reason to adjust the Soc at 50% or more should be explained.

R12/R94/R95 prescribe as below;

*“The RESS shall be at any state of charge, which allows the normal operation of the power train as recommended by the manufacturer.”*

Crush a [RESS or pack(s)] between a resistance and a crush plate described in figure 7 with a force of [100 kN] in [X seconds; how fast] during [Y seconds; how long] => **action item for German working group**

direction of travel and horizontally perpendicular to the direction of travel of the [RESS].

[Optionally, this test can be conducted with the mechanical load according to ECE-R12 Annex 3 or ECE R94 Annex 3 in the direction of travel and with the mechanical load according to ECE R95 Annex 4 in the direction horizontally perpendicular to the direction of travel. The mechanical load shall be determined by the vehicle manufacturer using test or simulation data and agreed by the Technical Service.]

In order to determine potential for fire hazard an evaluation for potential flammable concentrations of vapors shall be included by use of a minimum of two continuous spark sources located near anticipated sources of vapour such as vent opening or at the vent duct. The continuous spark sources are to provide at least two sparks per second with sufficient energy to ignite natural gas. (Reference to UL 2580-2011)

The device under test may be installed in a protective framework representative of what is provided in the vehicle. (Reference to UL 2580-2011)

### **Comment from (Sweden) regarding the use of protective framework**

This is needed to avoid imposing design limitations on RESS. Without the option of performing the test with “a protective framework representative of what is provided in the vehicle” the test will not represent the mechanical load exerted onto a RESS located within the protective structure of the vehicle. This imposes a risk to make it more difficult to design large RESS for EV in comparison to smaller RESS for HEV, hence imposing design limitations on the EV market.

Figure 7:

# Proposal how to structure the RESS safety requirements

12-14 April 2011 RESS-4-8

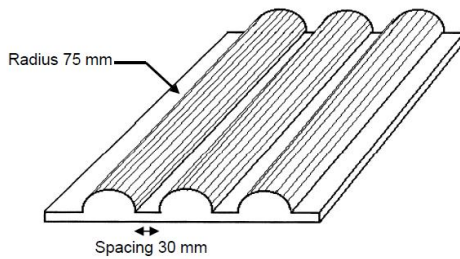

[Dimension of the crush plate:  
Orientation of the crush plate:

600 mm x 600 mm

~~decision of battery manufacturer~~ The orientation shall be agreed by the manufacturer and the Technical Service.

Position of the crush plate:

The position shall be agreed by the manufacturer and the Technical Service.]

~~To better precise the crush plate position with a drawing.~~

## ~~3.1. Records~~

~~Open circuit voltage of DUT shall be measured prior to initiation of crush test. Isolation measurement shall be done in accordance with annex1 ISO 6469-1, Se; or equivalent prior to initiation of crush test.~~

<JASIC Comment>

For large-sized batteries having relatively short height, it will be difficult to conduct this test in practice.

## ~~3.4.2.2.2 Acceptance criteria~~

During the test, including [1] h after the test, the [battery system] shall exhibit no evidence

- ~~a) of undefined visible venting~~
- ~~b) battery enclosure rupture (no degradation of protection degree)~~
- c) fire
- d) explosion.

<JASIC Comment>

The criteria should be made under the same philosophy as mechanical impact test. For the vehicles out of scope of R12/R94/R95, certain provisions to ensure the proper installation of RESS should be established.

Remark: introduced a criteria on the quantity of gas and to see also the definition, b) deleted because enclosure rupture is highly possible. Is it the concern?

For [RESS] using high voltage the isolation resistance measured at the end of the test shall maintain high voltage to ground isolation no less than 100  $\Omega$ /Volt.

## ~~3.4.2.3 Verification~~

~~a) to d) of 3.4.1.2.2. shall be checked by visual inspection.~~

# Proposal how to structure the RESS safety requirements

12-14 April 2011 RESS-4-8

## 3.5 Fire Resistance

### 3.5.1 Rationale

Simulates exposure of [RESS] to fire from the outside of the vehicle due to e.g. a fuel spill from a vehicle (either the vehicle itself or a nearby vehicle). This situation should leave the driver and passengers with enough time to evacuate and no explosion should occur in a later stage.

### 3.5.2 Requirement

The test is required for [RESS] to be placed at a level less than 1.5 m above ground. The test is carried out on one item.

#### 3.5.2.1 Conditions – vehicle based test

##### 3.5.2.1.1. SOC

The [RESS] shall be at any state of charge, which allows the normal operation of the power train as recommended by the manufacturer.

**3.5.2.1.2.** The RESS shall be conditioned of period of not less than 8 h at a temperature of  $20 \pm 5$  °C.

**3.5.2.1.3.** The RESS shall be installed in a testing fixture simulating actual mounting conditions as far as possible; no combustible material should be used for this except the material that is part of the RESS. The method whereby the RESS is fixed in the fixture shall correspond to the relevant specifications for its installation. In the case of [RESS] designed for a specific vehicle use, vehicle parts which affect the course of the fire in any way shall be taken into consideration.

**3.5.2.1.4.** The flame to which the RESS is exposed shall be obtained by burning commercial fuel for positive-ignition engines (hereafter called "fuel") in a pan. The quantity of fuel poured into the pan shall be sufficient to permit the flame, under free-burning conditions, to burn for the whole test procedure, i.e. at least 15 litres/m<sup>2</sup>. The fuel temperature should be  $20^{\circ}\text{C} \pm 5^{\circ}\text{C}$ .

Water should be poured at the bottom of the pan to ensure a flat bottom of the pan. The water temperature should be  $20^{\circ}\text{C} \pm 5^{\circ}\text{C}$ . The pan dimensions shall be chosen so as to ensure that the sides of the RESS are exposed to the flame. The pan shall therefore exceed the horizontal projection of the RESS by at least 20 cm, but not more than 50 cm. The sidewalls of the pan shall not project more than 8 cm above the level of the fuel at the start of the test.

In cases when the RESS is distributed over the vehicle it is possible to run the test on each subpart of the RESS.

If it is not possible to arrange with a  $20^{\circ}\text{C} \pm 5^{\circ}\text{C}$  of the fuel and the water then the test needs to be conducted with a 1 minute pre-heating period.

**3.5.2.1.5.** The pan filled with fuel shall be placed under the RESS in such a way that the distance between the level of the fuel in the pan and the RESS bottom

## Proposal how to structure the RESS safety requirements

12-14 April 2011 RESS-4-8

corresponds to the design height of the RESS above the road surface at the unladen mass. Either the pan, or the testing fixture, or both, shall be freely movable.

**3.5.2.1.6.** During phase C of the test, the pan shall be covered by a screen placed 3 cm +/- 1 cm above the fuel level. The screen shall be made of a refractory material, as prescribed in [Annex 2]. There shall be no gap between the bricks and they shall be supported over the fuel pan in such a manner that the holes in the bricks are not obstructed. The length and width of the frame shall be 2 cm to 4 cm smaller than the interior dimensions of the pan so that a gap of 1 cm to 2 cm exists between the frame and the wall of the pan to allow ventilation. Before the test the screen shall be heated to 308 K +/- 5 K (35 degrees C +/- 5 degrees C). The firebricks may be wetted in order to guarantee the repeatable test conditions.

**3.5.2.1.7.** If the tests are carried out in the open air, sufficient wind protection shall be provided and the wind velocity at pan level shall not exceed 2.5 km/h.

**3.5.2.1.8.** The test shall comprise of three phases B-D. If it is not possible to arrange with a  $20^{\circ}\text{C} \pm 5^{\circ}\text{C}$  of the fuel and the water then the test shall comprise of four phases.

### **3.5.2.1.8.1. Phase A: Pre-heating to ensure stable fuel temperature (Figure 1)**

This phase is required if it is not possible to arrange with a  $20^{\circ}\text{C} \pm 5^{\circ}\text{C}$  of the fuel and the water. The fuel in the pan shall be ignited at a distance of at least 3 m from the RESS and mock-up being tested. After 60 seconds pre-heating, the pan shall be placed under the RESS and mock-up. If the size of the pan is too large to be moved without risking liquid spills etc. then the RESS and test rig can be moved instead of the pan.

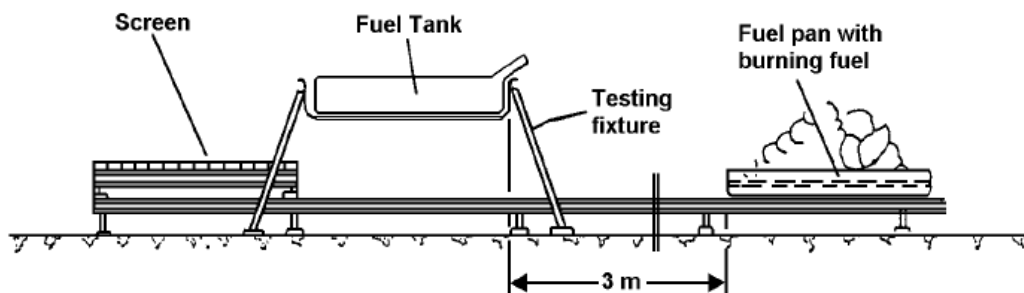

Figure 1

### **3.5.2.1.8.2. Phase B: Direct exposure to flame (Figure 2)**

For 70 seconds the RESS and mock-up shall be exposed to the flame from the freely burning fuel.

## Proposal how to structure the RESS safety requirements

12-14 April 2011 RESS-4-8

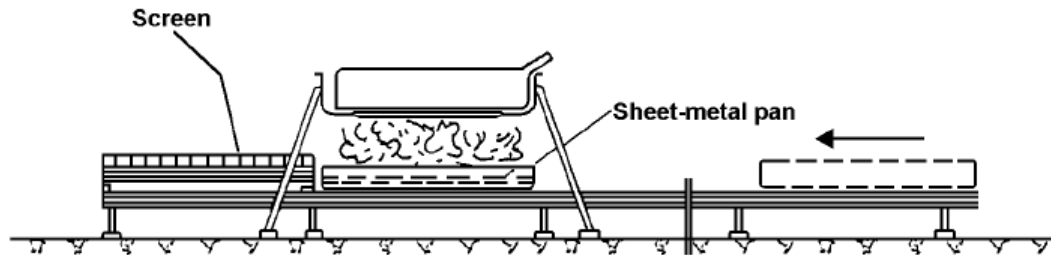

Figure 2

### 3.5.2.1.8.3. Phase C: Indirect exposure to flame (Figure 3)

As soon as phase B has been completed, the screen shall be placed between the burning pan and the RESS and mock-up. The RESS shall be exposed to this reduced flame for a further 60 seconds.

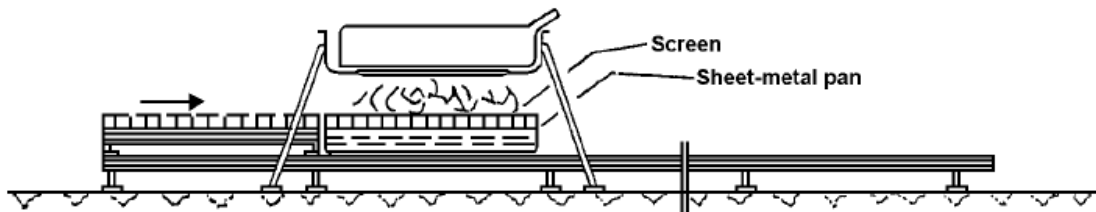

Figure 3

### 3.5.2.1.8.4. Phase D: End of test (Figure 4)

The burning pan covered with the screen shall be moved at least 3 m away from the RESS. No extinguishing of the RESS shall be done. The RESS shall be monitored for 24 h after the removal of the pan. At the manufacturer's discretion temperature measurements might be installed in the RESS and then phase D can be stopped as soon as a stable decrease of the RESS temperature is observed.

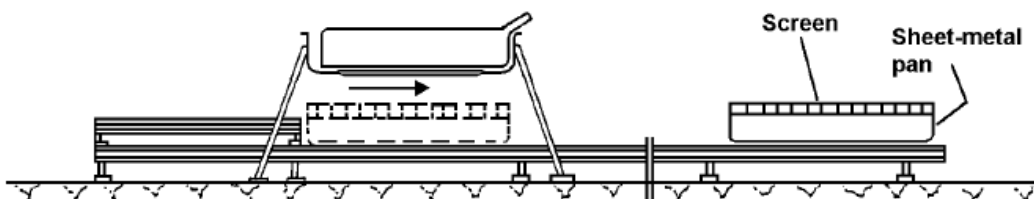

Figure 4

### 3.5.2.2 Conditions - component based test

A complete RESS is to be tested for this condition. However, if conducting this test on a RESS is deemed inappropriate due to size or weight; this test may be conducted utilizing subsystem(s) including respective battery module(s), provided that all portions of the battery module(s) of the RESS are evaluated. If tests are performed on subsystem basis, evidence shall be provided that the results are representative for RESS.

#### 3.5.2.2.1. SOC

## Proposal how to structure the RESS safety requirements

12-14 April 2011 RESS-4-8

The [RESS] shall be at any state of charge, which allows the normal operation of the power train as recommended by the manufacturer.

**3.5.2.2.2.** The RESS shall be conditioned of period of not less than 6 h at a temperature of  $20 \pm 5$  °C.

**3.5.2.2.3.** The RESS or module should be placed on a grating table positioned above the pan. The grating table shall be constructed by steel rods, diameter 6-10 mm, with 4-6 cm in between. If needed the steel rods could be supported by flat steel parts.

**3.5.2.2.4.** The flame to which the RESS is exposed shall be obtained by burning commercial fuel for positive-ignition engines (hereafter called "fuel") in a pan. The quantity of fuel poured into the pan shall be sufficient to permit the flame, under free-burning conditions, to burn for the whole test procedure, i.e. at least 15 litres/m<sup>2</sup>. The fuel temperature should be  $20^{\circ}\text{C} \pm 5^{\circ}\text{C}$ .

Water should be poured at the bottom of the pan to ensure a flat bottom of the pan. The water temperature should be  $20^{\circ}\text{C} \pm 5^{\circ}\text{C}$ . The pan dimensions shall be chosen so as to ensure that the sides of the RESS or module are exposed to the flame. The pan shall therefore exceed the horizontal projection of the RESS or module by at least 20 cm, but not more than 50 cm but for small RESS or module the minimum pan size shall be 50x50 cm. The sidewalls of the pan shall not project more than 8 cm above the level of the fuel at the start of the test.

If it is not possible to arrange with a  $20^{\circ}\text{C} \pm 5^{\circ}\text{C}$  of the fuel and the water then the test needs to be conducted with a 1 minute pre-heating period.

**3.5.2.2.5.** The pan filled with fuel shall be placed under the RESS or module in such a way that the distance between the level of the fuel in the pan and the RESS bottom is 50 cm. Either the pan, or the testing fixture, or both, shall be freely movable.

**3.5.2.2.6.** During phase C of the test, the pan shall be covered by a screen placed 3 cm +/- 1 cm above the fuel level. The screen shall be made of a refractory material, as prescribed in [Annex 2]. There shall be no gap between the bricks and they shall be supported over the fuel pan in such a manner that the holes in the bricks are not obstructed. The length and width of the frame shall be 2 cm to 4 cm smaller than the interior dimensions of the pan so that a gap of 1 cm to 2 cm exists between the frame and the wall of the pan to allow ventilation. Before the test the screen shall be heated to 308 K +/- 5 K (35 degrees C +/- 5 degrees C). The firebricks may be wetted in order to guarantee the repeatable test conditions.

**3.5.2.2.7.** If the tests are carried out in the open air, sufficient wind protection shall be provided and the wind velocity at pan level shall not exceed 2.5 km/h.

**3.5.2.2.8.** The test shall comprise of three phases. If it is not possible to arrange with a  $20^{\circ}\text{C} \pm 5^{\circ}\text{C}$  of the fuel and the water then the test shall comprise of four phases.

## Proposal how to structure the RESS safety requirements

12-14 April 2011 RESS-4-8

### 3.5.2.2.8.1. Phase A: Pre-heating to ensure stable fuel temperature (Figure 5)

This phase is required if it is not possible to arrange with a  $20^{\circ}\text{C} \pm 5^{\circ}\text{C}$  of the fuel and the water. The fuel in the pan shall be ignited at a distance of at least 3 m from the RESS or module being tested. After 60 seconds pre-heating, the pan shall be placed under the RESS or module. If the size of the pan is too large to be moved without risking liquid spills etc. then the RESS and test rig can be moved instead of the pan.

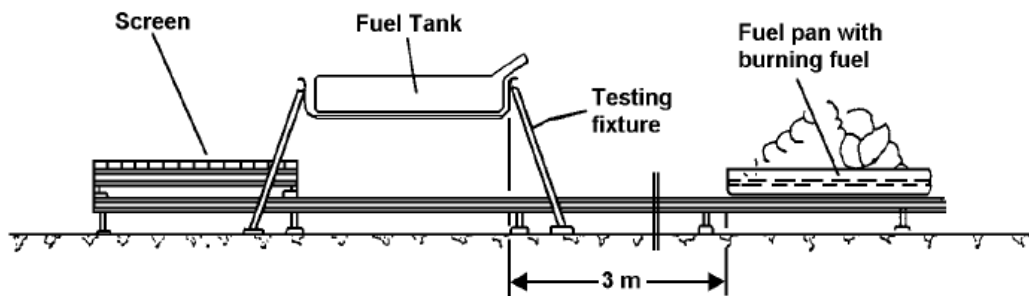

Figure 5

### 3.5.2.2.8.2. Phase B: Direct exposure to flame (Figure 6)

For 70 seconds the RESS or module shall be exposed to the flame from the freely burning fuel.

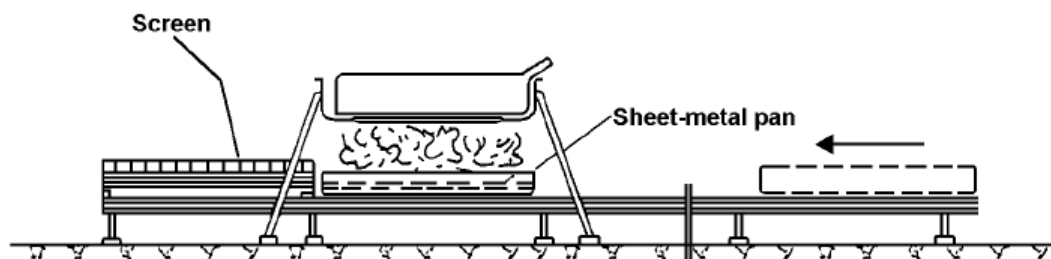

Figure 6

### 3.5.2.2.8.3. Phase C: Indirect exposure to flame (Figure 7)

As soon as phase B has been completed, the screen shall be placed between the burning pan and the RESS and mock-up. The RESS shall be exposed to this reduced flame for a further 60 seconds.

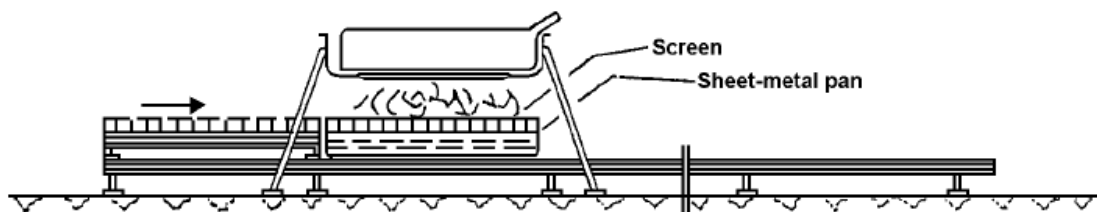

Figure 7

### 3.5.2.2.8.4. Phase D: End of test (Figure 8)



## Proposal how to structure the RESS safety requirements

12-14 April 2011 RESS-4-8

The burning pan covered with the screen shall be moved at least 3 m away from the RESS or module. No extinguishing of the RESS or module shall be done. The RESS or module shall be monitored for 24 h after the removal of the pan. At the manufacturers discretion temperature measurements might be installed in the RESS or module and then phase D can be stopped as soon as a stable decrease of the RESS or module temperature is observed.

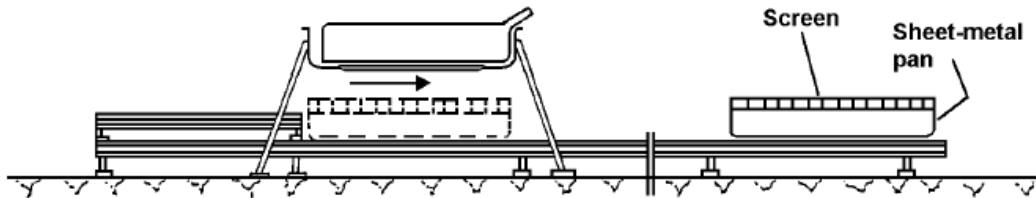

Figure 8

### 3.5.2.3 Acceptance criteria

During Phase A to D of the test, the RESS shall exhibit no evidence of rupture or explosion, as defined in Table X of this document [ref: SAE J2464 or UL2580].

No dangerous voltages shall be available on the chassi or RESS.

### 3.5.3 Verification

The explosion and rupture criterion is verified by ocular inspection. Indicators of rupture or explosion include, but are not limited to: sudden increase in flame intensity or size, emission of projectiles, loud noise.

Voltage levels towards ground shall be continuously measured during phase A to D.

If relevant after fire testing, isolation resistance shall be checked according to Annex 1.

# Proposal how to structure the RESS safety requirements

12-14 April 2011 RESS-4-8

## 3.5 Fire Resistance

### 2.1.2 Rationale

Simulates exposure of [RESS] to fire from the outside of the vehicle due to e.g. a fuel spill from a vehicle (either the vehicle itself or a nearby vehicle). This situation should leave the driver and passengers with enough time to evacuate and no explosion should occur in a later stage.

### 2.1.3 Requirement

The test is required for [RESS] to be placed at a level less than 1.5 m above ground. The test is carried out on one item. **as compared to R34 Annex 5 where 3 items are required.**

### 3.5.2.1 Conditions

**3.5.2.1.1.** The state of charge (SOC) of [RESS] shall be at the maximum which is possible during normal vehicle operation.

The [RESS] shall be at any state of charge, which allows the normal operation of the power train as recommended by the manufacturer.

If for some reason another SOC would pose a higher risk then this SOC should be used.

**3.5.2.1.2.** The [RESS] shall be conditioned of period of not less than 8 h at a temperature of  $[20 \pm 5 \text{ }^\circ\text{C}]$  equal to the maximum allowed operating temperature before the test starts. If there is reason to believe that any other temperature would pose a higher risk than this temperature should be used.

<JASIG Comment>

It is practically difficult to adjust the temperature at the test site while the influence of the RESS temperature is not assumed as to be significant.

**3.5.2.1.3.** The [RESS] shall be installed in a testing fixture simulating actual mounting conditions as far as possible; no combustible material should be used for this except the material that is part of the [RESS]. The method whereby the [RESS] is fixed in the fixture shall correspond to the relevant specifications for its installation. In the case of [RESS] designed for a specific vehicle use, vehicle parts which affect the course of the fire in any way shall be taken into consideration.

**3.5.2.1.4** The cooling system and the venting systems for prevention of overpressure shall **be remain** operative **during at the initiation of** the test. **At the manufacturer's discretion, such systems may be disabled.**

<JASIG Comment>

It is practically difficult to maintain the operation of such systems during the test and it is recommended to allow flexibility for the manufacturer to avoid the test would be considered as "void".

**3.5.2.1.5.** The flame to which the [RESS] is exposed shall be obtained by burning **Heptanes commercial fuel for positive ignition engines (hereafter called "fuel")** in a pan. The quantity of **fuel Heptanes** poured into the pan shall be sufficient to permit

# Proposal how to structure the RESS safety requirements

12-14 April 2011 RESS-4-8

the flame, under free-burning conditions, to burn for the whole test procedure, i.e. at least 25 litres/m<sup>2</sup>.

~~5.3. R 34 annex 5 : "The flame to which the tank is exposed shall be obtained by burning commercial fuel for positive ignition engines (hereafter called "fuel") in a pan."~~

~~Water should be poured at the bottom of the pan to ensure a flat bottom of the pan. The pan dimensions shall be chosen so as to ensure that the sides of the [RESS] are exposed to the flame. The pan shall therefore exceed the horizontal projection of the [RESS] by at least 20 cm, but not more than 50 cm. The sidewalls of the pan shall not project more than 8 cm above the level of the fuel Heptanes at the start of the test.~~

~~Remark: We suggest keeping the possibility to expose the RESS to a flame as for current R 34.~~

In cases when the [RESS] is distributed over the vehicle it is possible to run the test on each subpart of the [RESS].

<JASIC Comment>

The benefit to use Heptanes is not clear enough to require the use of unfamiliar material for vehicle testing.

The risk in the test operation in case of large-sized RESS should also be addressed since the pan dimension (i.e. size of flame) will be considerably huge and moving either the pan or the RESS in a safely manner will be difficult. It might be appropriate to have the maximum size of the pan.

~~3.5.2.1.6. The pan filled with fuel Heptanes shall be placed under the [RESS] in such a way that the distance between the level of the fuel Heptanes in the pan and the [RESS] bottom corresponds to the design height of the [RESS] above the road surface at the unladen mass. Either the pan, or the testing fixture, or both, shall be freely movable.~~

~~3.5.2.1.7. During phase C of the test, the pan shall be covered by a screen placed 3 cm +/- 1 cm above the fuel Heptanes level. The screen shall be made of a refractory material, as prescribed in [Annex 2]. There shall be no gap between the bricks and they shall be supported over the fuel Heptanes pan in such a manner that the holes in the bricks are not obstructed. The length and width of the frame shall be 2 cm to 4 cm smaller than the interior dimensions of the pan so that a gap of 1 cm to 2 cm exists between the frame and the wall of the pan to allow ventilation. Before the test the screen shall be heated to 308 K +/- 5 K (35 degrees C +/- 5 degrees C). The firebricks may be wetted in order to guarantee the repeatable test conditions.~~

~~3.5.2.1.8. The tests should be carried out in an ambient temperature of at least 20 °C. If the tests are carried out in the open air, sufficient wind protection shall be provided and the wind velocity at pan level shall not exceed 2.5 km/h.~~

<JASIC Comment>

The requirement of ambient temperature is too restrictive while the influence of the ambient temperature is not assumed to be significant.

# Proposal how to structure the RESS safety requirements

12-14 April 2011 RESS-4-8

3.5.2.1.9. The test shall comprise of four phases (see Appendix 1).

## 3.5.2.1.7.1. Phase A: Pre-heating (Figure 1)

The fuel Heptanes in the pan shall be ignited at a distance of at least 3 m from the [RESS] being tested. After 60 seconds pre-heating, the pan shall be placed under the [RESS]. If the size of the pan is too large to be moved without risking liquid spills etc. then the [RESS] and test rig can be moved instead of the pan.]

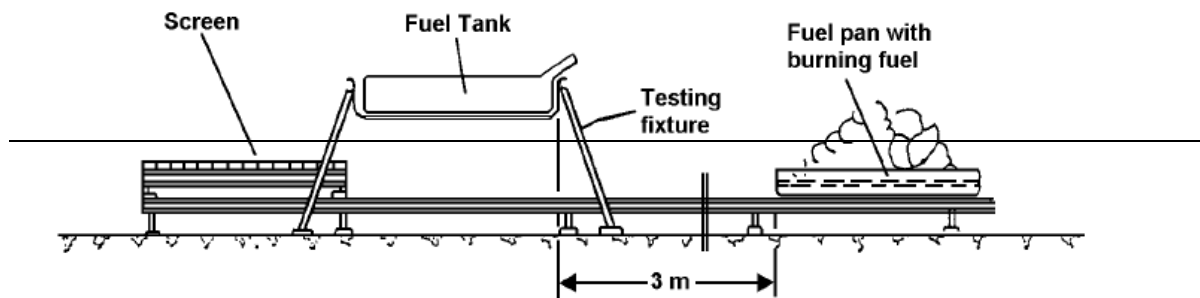

Figure 1

## 3.5.2.1.7.2. Phase B: Direct exposure to flame (Figure 2)

For 90 seconds the [RESS] shall be exposed to the flame from the freely burning fuel Heptanes.

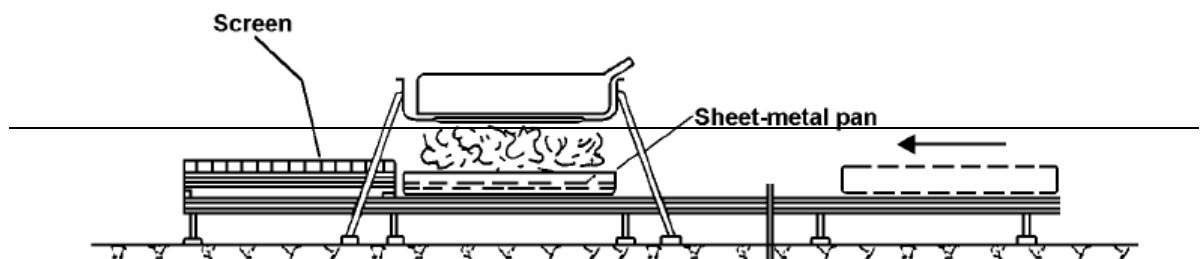

Figure 2

## 3.5.2.1.7.3. Phase C: Indirect exposure to flame (Figure 3)

As soon as phase B has been completed, the screen shall be placed between the burning pan and the [RESS]. The [RESS] shall be exposed to this reduced flame for a further [60] 90 seconds.

Instead of conducting Phase C of the test, Phase B may be continued for additional [60] 90 seconds at the manufacturer's discretion in those cases there is no reason to believe that this might pose a lower risk than the normal phase C.

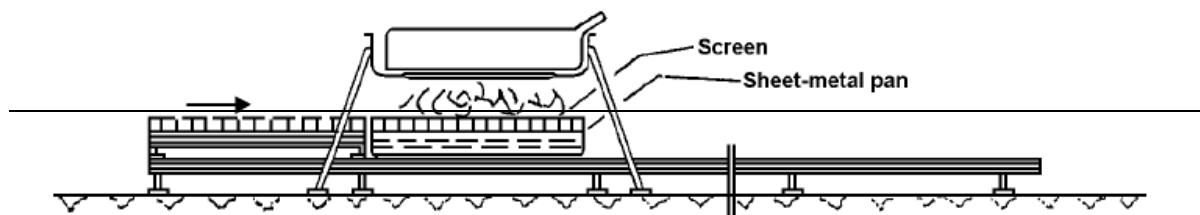

Figure 3

# Proposal how to structure the RESS safety requirements

12-14 April 2011 RESS-4-8

<JASIC Comment>

Extension of the heating period (60+60s → 90+90s) seems to be not logical.

## 3.5.2.1.4. Phase D: End of test (Figure 4)

The burning pan covered with the screen shall be moved back to its original position (phase A). No extinguishing of the [RESS] shall be done. The [RESS] and its temperature shall be monitored for 1h, 24h after the removal of the pan. The phase D can be stopped as soon as a decrease of the RESS temperature is observed.]

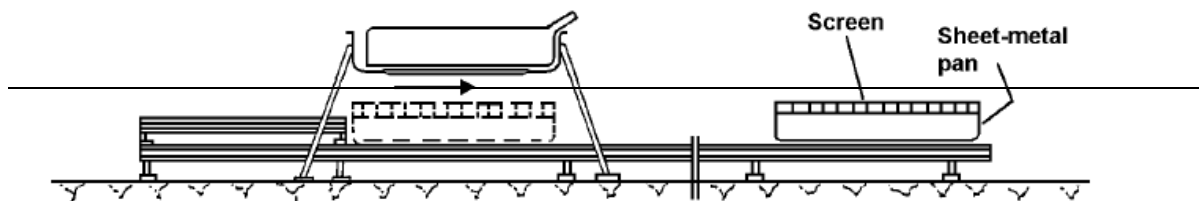

Figure 4

## 3.5.2.2 Acceptance criteria

During Phase A to D of the test, the [RESS] shall exhibit no evidence of explosion, not explode or rupture and no venting shall occur during phase A-C.

<JASIC Comment>

As this test condition simulates unusual circumstances, the requirement of explosion should be sufficient. The terms used for the requirement should be well defined and commonly used throughout the regulation.

## 2.1.4 Verification

The explosion criterion is verified by visual inspection. By no explosion means no sudden large increase in flames, no rapid release of energy, no pressure wave and no flying parts.

The pressure wave criteria needs to define a pressure limit and how to measure it

The venting criteria is evaluated either by signal from the BMS or if this is not possible by some other indication as agreed between the Technical Service and the manufacturer, this could be achieved by e.g. measuring gases produced during the test.

Remark: Is venting detection possible with the BMS ?

# Proposal how to structure the RESS safety requirements

12-14 April 2011 RESS-4-8

## 3.6 External Short Circuit Protection

### 3.6.1 Rationale

The purpose of the short circuit protection test it is to check the over-current protection function. This function shall interrupt the short circuit current in order to prevent the [RESS] from further related severe events caused by a short circuit current.

### 3.6.2 Requirement

#### 3.6.2.1 Conditions

The [RESS] shall be ~~at any state of charge MOSOC, which allows the normal operation of the power train~~ as recommended by the manufacturer.

The [RESS] to be tested shall be temperature stabilized ~~at maximum operating temperature alternatively 55 °C (UN 38.3) so that its external case temperature reaches minimum [23 °C]~~ and then the [RESS] shall be subjected to a short circuit condition with a total external resistance of less than 0.1 ohm ~~at minimum [23°C].~~ ~~The test equipment shall not limit the short circuit current during the test.~~ This short circuit condition is continued for at least one hour after the [RESS] external case temperature has returned to ~~initial temperature minimum [23°C]~~ unless the ~~operation of protection function to interrupt the short circuit current is confirmed.~~ Perform one SC, unless inhibited by the RESS.

~~The [RESS] shall be observed for a further [six hours] for the test to be concluded.~~

**Remark:** It has to be checked how such a requirement fits into the R 38.3 procedure.

#### **Comment (Sweden) regarding test conditions**

Recommend harmonizing with UN 38.3 to reduce redundancy testing. If harmonization is not done, then perform the test at MOSOC and max operating condition, since this defines the lowest margin to failure

#### 3.6.2.2 Acceptance criteria

During the test, including [1] h after the test, the [battery system] shall exhibit no evidence

- ~~a) of undefined visible venting~~
- b) battery enclosure rupture (no degradation of protection degree)
- c) fire
- d) explosion
- ~~e) electrolyte leakage~~

~~For [RESS] using high voltage the isolation resistance measured at the end of the test shall maintain high voltage to ground isolation no less than 100 Ω/Volt.~~

<JASIC Comment>

It is necessary to discuss the principle at what level of hazard shall be eliminated.

## Proposal how to structure the RESS safety requirements

12-14 April 2011 RESS-4-8

### **3.6.3 Verification**

a) to d) of 3.6.2.2 shall be checked by visual inspection.

~~The isolation resistance shall be measured according to Annex 1.~~

# Proposal how to structure the RESS safety requirements

12-14 April 2011 RESS-4-8

## 3.7 Overcharge Protection (ISO 12405-1)

### 3.7.1 Rationale

The purpose of the overcharge protection is to verify the functionality of the overvoltage protection, i.e. that the RESS is protected against excessive voltage levels outside of the cell spec. to avoid severe events caused by an overcharging, for example it interrupts the current or voltage or limits it to an acceptable value.

### 3.7.2 Requirement

#### 3.7.2.1 Conditions

The following requirements can be conducted with the [RESS] [or with the battery module(s)] of the [RESS].

[If requirements are performed on [battery module basis], evidence shall be provided that the results are representative for [RESS].]

#### **Comment (Sweden) regarding SOC levels for testing**

The SOC level has to be set in relation to the RESS under test, since this voltage working window is a design parameter and will vary between different vehicle manufacturers and types of electrified vehicles, otherwise the test conditions will not be "normal operating conditions".

We suggest considering SAE J2929 and/or UL 2580 in addition to ISO 12405 as reference for test design and acceptance criteria.

Perform one SC, unless inhibited by the RESS.

#### **Comment (Sweden) regarding tests conditions**

Extensive research is being done on Li-ion additives that will facilitate overvoltage protection at cell level. A realistic time frame for market introduction is  $\geq 5$  years. As an increasing number of potential Li-ion battery risks are being managed on a materials or chemical level, the necessity of protective electronic circuitry may diminish. This must be taken into consideration when determining test criteria, as these must not create obstacles for technology development.

~~The [RESS] shall be at RT, with a SOC of [80] % fully charged and under normal operating conditions~~

**Remark:** Influence of no-cooling, switched-off cooling etc. has to be included AND to avoid safety requirements on cooling system from battery, depends on decision of vehicle or battery manufacturer

[Main contactors are closed if any; battery system is controlled by the BCU]

If it includes safety features to prevent overcharging, if BCU has no safety features, the RESS or the battery or module have to be safe "stand-alone"



# Proposal how to structure the RESS safety requirements

12-14 April 2011 RESS-4-8

**Remark:** If test on module level, there is no BCU or BCU has a special management function to prevent overcharging

The test shall be performed with all integrated passive protection devices operational. Active charge control of the test equipment shall be disconnected.

**Remark:** Probably there are several passive protection devices

The normal charging of the application shall be described as multiple from 1C-Rate from cells. If cells with different C-Rates are used, the highest value shall be used.

The [RESS] shall be overcharged with at least two times C-Rate referring to normal charge mode of application which is agreed by manufacturer and Technical Service

**Remark:** To respect different cell-types and charging mechanism

<JASIC Comment>

Charge current is not clearly defined. Definition of C-Rate is necessary.

**Remark:** Less than two times rate could lead to possible problems. A lower value than 2C could be more severe.

## 3.7.2.2 Acceptance criteria

During the test, including [1] h after the test, the battery system shall exhibit no evidence of

- a) of undefined visible venting
- b) battery enclosure rupture (no degradation of protection degree)
- c) fire
- d) explosion.

For [RESS] using high voltage the isolation resistance measured at the end of the test shall maintain high voltage to ground isolation no less than 100  $\Omega$ /Volt.

[[1] after the test the [RESS] shall be re-used]

<JASIC Comment>

It is necessary to discuss the principle at what level of hazard shall be eliminated.

## 3.1.5 Verification

- a) to d) of 3.7.2.2 shall be checked by visible inspection after test
- b) Review of safety concept regarding ECE R13 H, Annex 8 or equal without test
- c) Analysis of measurement data and calculation

The isolation resistance shall be measured according to Annex 1.

# Proposal how to structure the RESS safety requirements

12-14 April 2011 RESS-4-8

## 3.8 Over-discharge Protection

### • Rationale

The purpose of the over-discharge protection test it is to check the functionality of the over-discharge protection function. This **functionality device, if any**, shall interrupt the over-discharge current in order to prevent the Device under Test (DUT) from any further related severe events caused by an over-discharge current.

### • Requirement

#### 3.8.2.1 Conditions

For [RESS] which do not need an over-discharge protection the manufacturer shall demonstrate to provide evidence to the Technical Service which shows that any over-discharge and standard charge afterwards does not lead to any situation described in the acceptance criteria.

#### => Footnote explanation

For [RESS] which need an over-discharge protection the following test shall be conducted with the [RESS] [or with [module(s)] of the RESS].

[If tests are performed on [module basis], evidence shall be provided that the results are representative for [RESS].]

The [RESS] shall be at room temperature (RT), charged as under normal operating conditions with the cooling system operating (main contactors are closed if any, battery system are controlled by the [battery control unit (BCU)]). The test shall be performed with integrated passive circuit protection devices operational. **Active discharge control of** The test equipment **shall not prevent the over-discharge of the DUT be disconnected.**

Perform a standard discharge. When reaching the normal discharge limits, discharging with 1C rate shall be continued.

Discharging shall be continued until the [RESS] interrupt the discharging automatically.

Direct after the over-discharging a ~~standard charging~~ **SC should** be conducted if not inhibited by the **[RESS]**.

#### **Comment (Sweden) regarding discharge conditions for overdischarge test**

Discharge current needs to be adjusted depending on normal discharge conditions for the vehicle type, e.g. 1C may be "normal" for HEV/PHEV but too high for EV, where C/3 is used in other standards (SAE J2929).

We suggest considering SAE J2929 and UL2580 as reference in addition to ISO 12405

#### **3.8.2.2 Acceptance criteria**

During the test, including [1] h after the test, the [battery system] shall exhibit no evidence of

**[a) of undefined visible venting]**

**=> action item for German working group / UTAC /SP/ Autoliv**

b) ~~battery enclosure rupture (no degradation of protection degree)~~

e) fire

d) explosion.

## Proposal how to structure the RESS safety requirements

12-14 April 2011 RESS-4-8

~~For [RESS] using high voltage the isolation resistance measured at the end of the test shall maintain high voltage to ground isolation not less than 100  $\Omega$ /Volt when the RESS is dedicated to a vehicle where the RESS is not galvanical connected to an AC system. Otherwise the high voltage to ground isolation has to be not less than 500  $\Omega$ /Volt.~~

~~However, if all AC high voltage buses are protected by one of the 2 following measures, isolation resistance between the high voltage bus and the electrical chassis shall have a minimum value of 100  $\Omega$ /V of the working voltage:~~

- ~~(a) Double or more layers of solid insulators, barriers or enclosures that meet the requirement in paragraph [5.1.1. of ECE R100.0]1 independently, for example wiring harness;~~
- ~~(b) Mechanically robust protections that have sufficient durability over vehicle service life such as motor housings, electronic converter cases or connectors;~~

.....  
JASIC Comment>

.....  
It is necessary to discuss the principle at what level of hazard shall be eliminated.  
.....

### ● ~~Verification~~

~~[a) to d) of 3.8.2.2 shall be checked by visual inspection.]~~

~~Isolation resistance shall be checked according to Annex 1.~~

## 3.9 Over-temperature Protection

- **Rationale**

Verify the functionality of the over-temperature protection, **if any necessary for safety reasons** that prevents the operation at over-temperatures inside the [RESS]. **This test should simulate the lost of thermal control.**

**<JASIC Comment>**

This procedure imposes unreasonable design restriction to have cut-off function, although another solution, e.g. protection by PTC of cell, may exist.

As this procedure has never discussed at international standardization bodies, careful review with a view to the practicality is necessary.

**Comment (Sweden) regarding performing tests on RESS under electrical load**

Unless there is some kind of load cycle this procedure will simulate parking in a (very?) hot area rather than loss of cooling functionality.

As real life vehicle collisions may occur while electric vehicles are driving, the need of exposing the RESS to an electric load (analogue to driving the vehicle at the test speed of ECE-R 94) should be discussed during next RESS meeting.

- **Requirement**

When the maximum working temperature of the [RESS], specified by the manufacturer, is exceeded, **the [RESS] high voltage buses shall be opened [or the battery cannot be operated]** at the latest [5 min] after this temperature is reached.

**After the test, the components shall be functional.**

### 3.9.2.1 **Conditions**

The [RESS] shall be at **MOSOC** any state of charge, which allows the normal operation of the power train as recommended by the manufacturer.

The [RESS] shall be placed in a convective oven or climatic chamber (hereby called over-temperature room). The over-temperature room temperature shall be increased at a rate of  $5\text{ °C/min} \pm 2\text{ °C/min}$  until it reaches the maximum working temperature of the [RESS], specified by the manufacturer + 20°C. The [RESS] temperature shall be monitored by the measurement devices which are integrated inside the [RESS] by the manufacturer.

~~Temperature measurement shall be performed inside the [RESS]. Cooling system shall be deactivated during the over-temperature test, and reactivated for the verification in 3.9.3.~~

The manufacturer shall provide the technical service with the relevant technical information dossier of the measurement device. ~~The content of this information dossier shall be provided by the technical service.~~

~~The test shall be interrupted when the requirement is satisfied or when the [RESS] reaches or exceeds the maximum working temperature specified by the manufacturer for more than 5 min without satisfying the requirement.~~

# Proposal how to structure the RESS safety requirements

12-14 April 2011 RESS-4-8

Perform a SC at the end of the test unless inhibited by the RESS.

**Comment (Sweden) regarding requirements for interrupting the test**  
What is required to have the test requirement satisfied? A disconnection of the battery?

## 3.9.2.2 Acceptance criteria

~~The [RESS] complies with the requirement when operation of the RESS stops, the signal related to the stop of operation physical opening sent by the BMS is detected.~~

~~[a) of undefined visible venting]~~

~~=> action item for German working group / UTAC /SP/ Autoliv~~

~~b) battery enclosure rupture (no degradation of protection degree)~~

~~c) fire~~

~~d) explosion.~~

### • Verification

~~[The internal temperature and the signal related to the opening of the high voltage buses of the [RESS] are monitored. In order to verify the functionality of the components, the [RESS] shall rest until it reaches the ambient temperature ( $25^{\circ}\text{C} \pm 5^{\circ}\text{C}$ ). A charge/discharge cycle shall be applied to the [RESS]. The charge and discharge shall be functional.~~

~~During the test and before the verification, to give the possibility to make a reset of the default.]~~

## **3.10 Protection against direct contact (related to R100)**

### **3.10.1 Rationale**

Verify the functionality that protects persons to come in contact with high voltage live parts (only for [RESS] above 60 VDC). This requirement has to be proved under ECE R100.]

# Proposal how to structure the RESS safety requirements

12-14 April 2011 RESS-4-8

## 3.11 Emission

### 3.11.1 Rationale

Possible emission of gases caused by the energy conversion process during normal use shall be considered.

### 3.11.2 Requirement

[Open type traction batteries shall meet the requirements of ECE R100 according to hydrogen emissions.]

⇒ Check the requirements of ECE R100 by German working

⇒

Systems with a closed chemical process are considered as emission-free under normal operation (e.g. Li-ion).

Other technologies shall be evaluated by the manufacturer and the Technical Service according possible emissions under normal operation.

#### 3.11.2.1 Conditions

#### 3.11.2.2 Acceptance criteria

For hydrogen emissions see ECE R100.

Systems with closed chemical process are emission-free and no verification is necessary.

### 3.11.3 Verification

For hydrogen emissions see ECE R100.

The closed chemical process has to be described by the manufacturer.

<JASIC Comment>

“Open type traction battery” is already defined in R100 and R100 has a hydrogen emission requirement for open type traction battery. Therefore, there is no need to have additional requirement for open type traction battery since compliance with R100 will anyway be required for vehicle approval.

Batteries other than open type traction battery will not cause any additional danger of gaseous emission during normal operation and therefore no need to make this requirement in this regulation.

## ANNEX 1: MEASUREMENT OF ISOLATION RESISTANCE

### 1. Measurement method

The isolation resistance measurement shall be conducted by selecting an appropriate measurement method from among those listed in Paragraphs 1.1. through 1.2., depending on the electrical charge of the live parts or the isolation resistance, etc.

The range of the electrical circuit to be measured shall be clarified in advance, using electrical circuit diagrams, etc.

Moreover, modification necessary for measuring the isolation resistance may be carried out, such as removal of the cover in order to reach the live parts, drawing of measurement lines, change in software, etc.

In cases where the measured values are not stable due to the operation of the on-board isolation resistance monitoring system, etc., necessary modification for conducting the measurement may be carried out, such as stopping of the operation of the device concerned or removing it. Furthermore, when the device is removed, it shall be proven, using drawings, etc., that it will not change the isolation resistance between the live parts and the electrical chassis.

Utmost care shall be exercised as to short circuit, electric shock, etc., for this confirmation might require direct operations of the high-voltage circuit.

#### 1.1. Measurement method using DC voltage from off-vehicle sources

##### 1.1.1. Measurement instrument

An isolation resistance test instrument capable of applying a DC voltage higher than the working voltage of the high voltage bus shall be used.

##### 1.1.2. Measurement method

An insulator resistance test instrument shall be connected between the live parts and the electrical chassis. Then, the isolation resistance shall be measured by applying a DC voltage at least half of the working voltage of the high voltage bus.

If the system has several voltage ranges (e.g. because of boost converter) in galvanically connected circuit and some of the components cannot withstand the working voltage of the entire circuit, the isolation resistance between those components and the electrical chassis can be measured separately by applying at least half of their own working voltage with those component disconnected.



## Proposal how to structure the RESS safety requirements

12-14 April 2011 RESS-4-8

1.2. Measurement method using the vehicle's own [RESS] as DC voltage source

1.2.1. Test vehicle conditions

The high voltage-bus shall be energized by the vehicle's own [RESS] and/or energy conversion system and the voltage level of the [RESS] and/or energy conversion system throughout the test shall be at least the nominal operating voltage as specified by the vehicle manufacturer.

1.2.2. Measurement instrument

The voltmeter used in this test shall measure DC values and shall have an internal resistance of at least 10 MΩ.

1.2.3. Measurement method

1.2.3.1. First step

The voltage is measured as shown in Figure 1 and the high voltage Bus voltage ( $V_b$ ) is recorded.  $V_b$  shall be equal to or greater than the nominal operating voltage of the [RESS] and/or energy conversion system as specified by the vehicle manufacturer.

Figure 1 - Measurement of  $V_b$ ,  $V_1$ ,  $V_2$

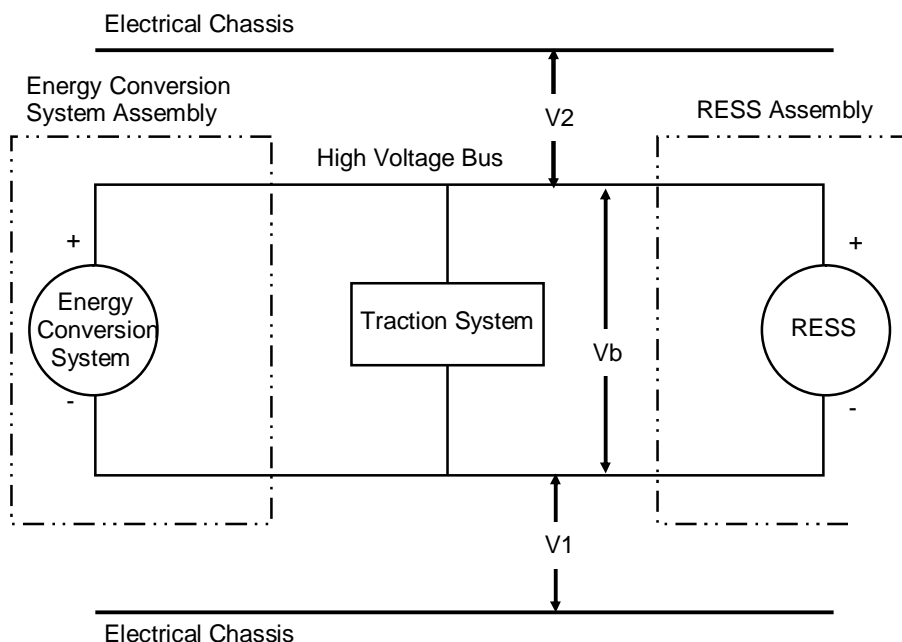

## Proposal how to structure the RESS safety requirements

12-14 April 2011 RESS-4-8

### 1.2.3.2. Second step

Measure and record the voltage ( $V_1$ ) between the negative side of the high voltage bus and the electrical chassis (see Figure 1).

### 1.2.3.3. Third step

Measure and record the voltage ( $V_2$ ) between the positive side of the high voltage bus and the electrical chassis (see Figure 1).

### 1.2.3.4. Fourth step

If  $V_1$  is greater than or equal to  $V_2$ , insert a standard known resistance ( $R_o$ ) between the negative side of the high voltage bus and the electrical chassis. With  $R_o$  installed, measure the voltage ( $V_1'$ ) between the negative side of the high voltage bus and the electrical chassis (see Figure 2).

Calculate the electrical isolation ( $R_i$ ) according to the following formula:

$$R_i = R_o \cdot (V_b / V_1' - V_b / V_1) \quad \text{or} \quad R_i = R_o \cdot V_b \cdot (1 / V_1' - 1 / V_1)$$

Figure 2 - Measurement of  $V_1'$

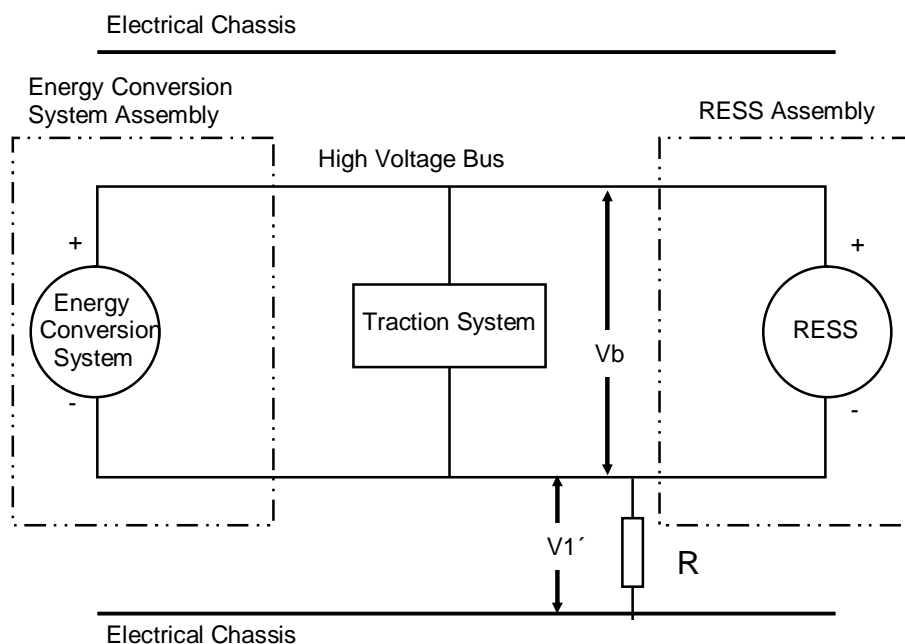

If  $V_2$  is greater than  $V_1$ , insert a standard known resistance ( $R_o$ ) between the positive side of the high voltage bus and the electrical chassis. With  $R_o$  installed, measure the voltage ( $V_2'$ ) between the positive side of the high voltage bus and the electrical chassis. (See Figure 3). Calculate the electrical isolation ( $R_i$ ) according to the formula

## Proposal how to structure the RESS safety requirements

12-14 April 2011 RESS-4-8

shown. Divide this electrical isolation value (in  $\Omega$ ) by the nominal operating voltage of the high voltage bus (in volts).

Calculate the electrical isolation ( $R_i$ ) according to the following formula:

$$R_i = R_o \cdot (V_b/V_2' - V_b/V_2) \quad \text{or} \quad R_i = R_o \cdot V_b \cdot (1/V_2' - 1/V_2)$$

Figure 3 - Measurement of  $V_2'$

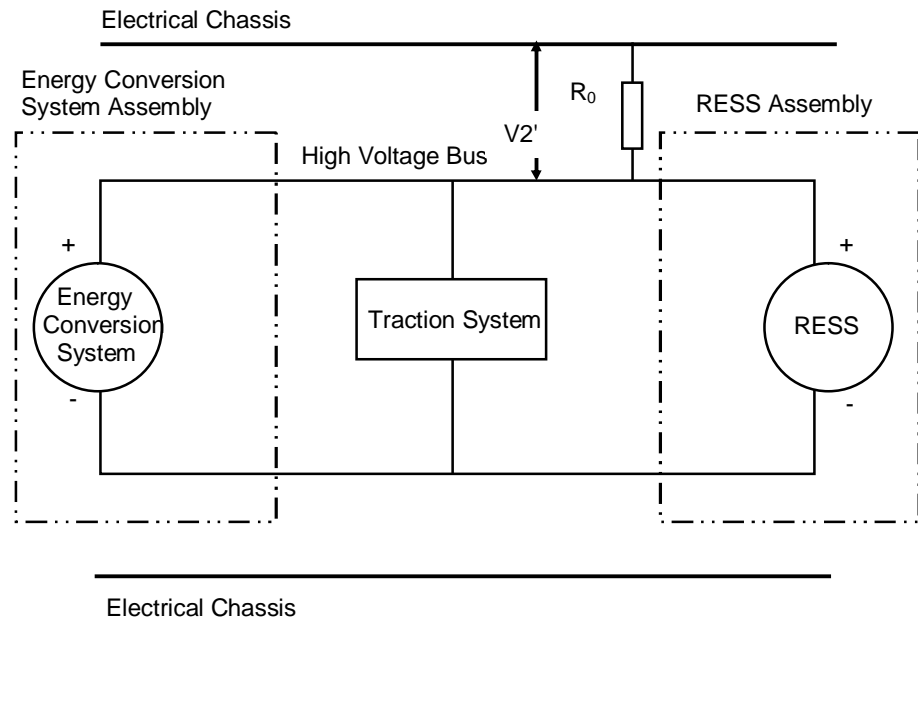

### 1.2.3.5. Fifth step

The electrical isolation value  $R_i$  (in  $\Omega$ ) divided by the working voltage of the high voltage bus (in volts) results in the isolation resistance (in  $\Omega/V$ ).

NOTE 1: The standard known resistance  $R_o$  (in  $\Omega$ ) should be the value of the minimum required isolation resistance (in  $\Omega/V$ ) multiplied by the working voltage of the vehicle plus/minus 20 per cent (in volts).  $R_o$  is not required to be precisely this value since the equations are valid for any  $R_o$ ; however, a  $R_o$  value in this range should provide good resolution for the voltage measurements.

# Proposal how to structure the RESS safety requirements

12-14 April 2011 RESS-4-8

## ANNEX 2: DIMENSIONS AND TECHNICAL DATA OF FIREBRICKS

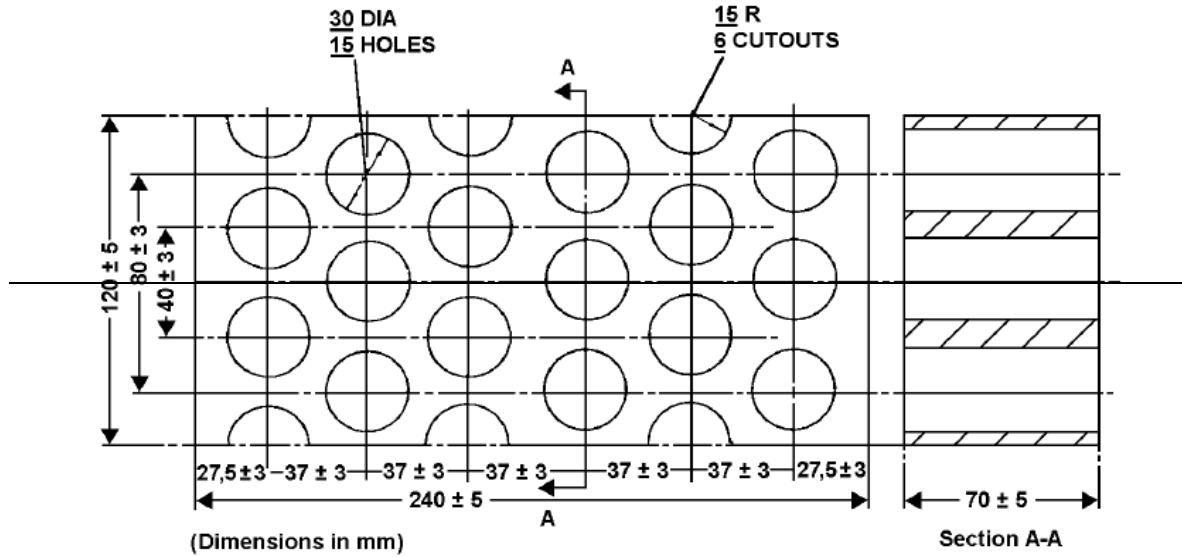

Fire resistance	(Seeger-Kegel) SK 30
Al <sub>2</sub> O <sub>3</sub> content	30 - 33 per cent
Open porosity (P <sub>o</sub> )	20 - 22 per cent vol.
Density	1,900 - 2,000 kg/m <sup>3</sup>
Effective holed area	44.18 per cent

# Proposal how to structure the RESS safety requirements

12-14 April 2011 RESS-4-8

## B) ADDITIONAL REQUIREMENTS?

### **IMMERSION TEST (RESS COMPLETE UNDER WATER)**

Rationale for the necessity maybe by NL.

Flooded roads are common in other areas also. A test is specified in SAE J2464.

REMARK: Immersion will not cause any safety critical phenomena for RESS.

#### **Remark from Korea:**

§ Additional Requirement: Immersion Test

In the past decade, we witnessed many floods around the world. The **Hurricane Katrina** in 2005 has left huge flood damage to the southern part of USA. The Queensland in Australia also was flooded as recently as January this year. The centre of Seoul, Korea, was flooded to the waist deep in Sep, 2010.

An immersion test should be included. The sea water, as fluid, may be appropriate. The electrical safety as well as chemical safety (for example, toxicity) should be secured.

<JASIC Comment>

Immersion will not cause any safety critical phenomena for RESS and therefore no need to make this requirement in this regulation.

### **[DUST]**

#### **MARKING**

ISO 6469-3 and R100

#### **EMC**

R10

### **Tell-tale**

<JASIC Comment>

General requirement in case of single failure to the system component, such as safe-mode operation, indication to the customer, tell-tale, etc., should be examined.

### **[Storage of RESS at low and high temperature]**