

**Economic and Social Council**Distr.: General  
1 August 2012

Original: English

---

**Economic Commission for Europe****Inland Transport Committee****World Forum for Harmonization of Vehicle Regulations****158<sup>th</sup> session**

Geneva, 13-16 November 2012

Item 4.7.24 of the provisional agenda

**1958 Agreement – Consideration of draft amendments  
to existing Regulations submitted by GRE****Proposal for Supplement 4 to the 01 series of amendments to  
Regulation No. 123 (Adaptive front lighting systems (AFS))****Submitted by the Working Party on Lighting and Light-Signalling\***

The text reproduced below was adopted by the Working Party on Lighting and Light-Signalling (GRE) at its sixty-seventh session to update the definition of "type", to introduce into Regulation No. 48 a definition of Gonio(photo)meter, to amend the existing description of the goniometer, to correct and harmonize the provisions concerning approval markings and to improve the accuracy of the test procedures on the stability of the photometric performance. It is based on ECE/TRANS/WP.29/GRE/2012/7, ECE/TRANS/WP.29/GRE/2012/8, ECE/TRANS/WP.29/GRE/2012/9 and ECE/TRANS/WP.29/GRE/2012/10, all not amended (ECE/TRANS/WP.29/GRE/67, paras. 24, 28, 29 and 30). It is submitted to the World Forum for Harmonization of Vehicle Regulations (WP.29) and to the Administrative Committee AC.1 for consideration.

---

\* In accordance with the programme of work of the Inland Transport Committee for 2010–2014 (ECE/TRANS/208, para. 106, ECE/TRANS/2010/8, programme activity 02.4), the World Forum will develop, harmonize and update Regulations in order to enhance the performance of vehicles. The present document is submitted in conformity with that mandate.

Paragraph 1.16., amend to read:

- "1.16. "Systems of different types" means systems which differ in such essential respects as:
- 1.16.1. The trade name or mark( s);
- 1.16.2. The inclusion or elimination of components capable of altering optical characteristics/ photometric properties of the system;
- 1.16.3. Suitability for right-hand or left-hand traffic or for both traffic systems;
- 1.16.4. The front-lighting function( s), mode( s) and classes produced;
- 1.16.5. The characteristic( s) of the signal( s), specified for the system;"

Insert new paragraphs 3.5. to 3.5.3., to read:

- "3.5. LED module(s) submitted along with the approval of the AFS:
- 3.5.1. Shall bear the trade name or mark of the applicant. This marking shall be clearly legible and indelible;
- 3.5.2. Shall bear the specific identification code of the module. This marking shall be clearly legible and indelible.  
This specific identification code shall .... from the same applicant.
- 3.5.3. If the LED module(s) are non-replaceable, the markings for LED module(s) are not required."

Annex 2, amend to read:

## "Annex 2

### Examples of arrangements of approval marks

Example 1

$a \geq 8$  mm (on glass)  
 $a \geq 5$  mm (on plastic material)

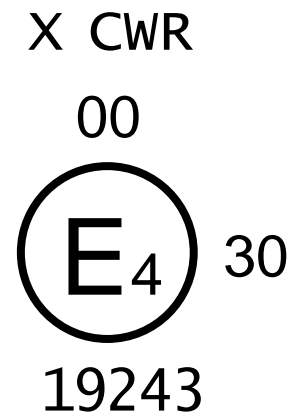
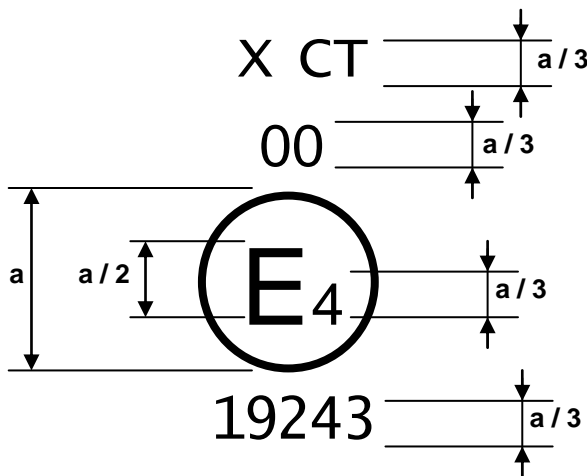

..."

*Annex 4, paragraph 1.1.2.2., amend to read:*

"1.1.2.2. Photometric test:

To comply with the requirements of this Regulation, the photometric values shall be verified in the following points:

Class C passing beam, and each specified other passing beam class: 50V, B50L, and 25RR, if applicable.

Driving beam, under neutral state conditions: point of  $I_{max}$ .

Another aiming may be carried out to allow for any deformation of the test sample base due to heat (the change of the position of the cut-off line is covered in paragraph 2. of this annex).

Except for points B50L, a 10 per cent discrepancy between the photometric characteristics and the values measured prior to the test is permissible including the tolerances of the photometric procedure. The value measured at point B50L shall not exceed the photometric value measured prior to the test by more than 170 cd."

*Annex 9, paragraphs 1.1. to 1.5., amend to read:*

"1. General provisions

1.1. The system or part(s) thereof shall be mounted on a gonio(photo)meter system.

1.2. The luminous intensity values shall be determined by means of a photoreceptor contained within a square of 65 m side and set up to a distance of at least 25m forward of the centre of reference of each lighting unit perpendicular to the measurement axis from the origin of the gonio(photo)meter system.

1.3. During photometric measurements, stray reflections should be avoided by appropriate masking.

1.4. The luminous intensities are measured at a nominal distance of 25 m.

1.5. The angular coordinates are specified in degrees on a sphere corresponding to a gonio(photo)meter system as defined in Regulation No. 48. (see diagram 1).

Diagram 1 ....."

*Annex 11, paragraph 4.3.1.1., amend to read:*

"4.3.1.1. For each existing class of passing beam and for the driving beam, a photometric measurement shall be carried out after one minute of operation of the respective lighting units and for the following test points:

Passing beam:	25RR
Driving beam:	HV "