

# UN/SCETDG/50/INF.7/Add.1 UN/SCEGHS/32/INF.5/Add.1

---

## **Committee of Experts on the Transport of Dangerous Goods and on the Globally Harmonized System of Classification and Labelling of Chemicals**

16 September 2016

### **Sub-Committee of Experts on the Transport of Dangerous Goods**

#### **Fiftieth session**

Geneva, 27 November – 6 December 2016

Item 7 (g) of the provisional agenda

**Issues relating to the Globally Harmonized System  
of Classification and Labelling of Chemicals: Use  
of the Manual of Tests and Criteria in the context  
of the GHS**

### **Sub-Committee of Experts on the Globally Harmonized System of Classification and Labelling of Chemicals**

#### **Thirty-second session**

Geneva, 7 – 9 December 2016

Item 2(b) of the provisional agenda

**Work of the TDG Sub-Committee on matters of  
interest to the GHS Sub-Committee**

## **Revision of the Manual of Tests and Criteria: Part I: Sections 10 to 17**

**Transmitted by the Chairman of the Working Group on Explosives on  
behalf of the Working Group**

## **PART I**

# **CLASSIFICATION PROCEDURES, TEST METHODS AND CRITERIA RELATING TO EXPLOSIVES ~~OF CLASS 1~~**

## CONTENTS OF PART I

**NOTE 1:** The country or organization of origin of each test method is indicated in brackets after each test name.

**NOTE 2:** The test method recommended for use with each test type is indicated in **bold** and by an asterisk (see subsection 1.6 of the General Introduction).

<u>Section</u>	<u>Page</u>
<b>10. INTRODUCTION TO PART I</b> .....	
10.1 PURPOSE.....	
10.2 SCOPE .....	
10.3 ACCEPTANCE PROCEDURE.....	
10.3.1 General description .....	
10.3.2 Test types .....	
10.3.3 Application of the test methods .....	
10.4 PROCEDURE FOR ASSIGNMENT TO A DIVISION OF <u>THE CLASS <del>1.1</del> OF EXPLOSIVES</u> .....	
10.4.1 General description .....	
10.4.2 Test types .....	
10.4.3 Application of the test methods .....	
10.5 EXAMPLES OF TEST REPORTS .....	
<b>11. TEST SERIES 1</b> .....	
11.1 INTRODUCTION .....	
11.2 TEST METHODS.....	
11.3 TEST CONDITIONS .....	
11.4 SERIES 1 TYPE (a) TEST PRESCRIPTION .....	
11.4.1 <b>Test 1 (a) * UN gap test (UN)</b> .....	
11.5 SERIES 1 TYPE (b) TEST PRESCRIPTION .....	
11.5.1 <b>Test 1 (b) * Koenen test (D)</b> .....	
11.6 SERIES 1 TYPE (c) TEST PRESCRIPTIONS .....	
11.6.1 <b>Test 1 (c) (i) * Time/pressure test (GB)</b> .....	
11.6.2 Test 1 (c) (ii) Internal ignition test (USA) .....	
<b>12. TEST SERIES 2</b> .....	
12.1 INTRODUCTION .....	
12.2 TEST METHODS.....	
12.3 TEST CONDITIONS .....	
12.4 SERIES 2 TYPE (a) TEST PRESCRIPTION .....	
12.4.1 <b>Test 2 (a) * UN gap test (UN)</b> .....	
12.5 SERIES 2 TYPE (b) TEST PRESCRIPTION .....	
12.5.1 <b>Test 2 (b) * Koenen test (D)</b> .....	
12.6 SERIES 2 TYPE (c) TEST PRESCRIPTIONS .....	
12.6.1 <b>Test 2 (c) (i) * Time/pressure test (GB)</b> .....	
12.6.2 Test 2 (c) (ii) Internal ignition test (USA) .....	

CONTENTS OF PART I (continued)

<u>Section</u>		<u>Page</u>
<b>13.</b>	<b>TEST SERIES 3</b> .....	
13.1	INTRODUCTION .....	
13.2	TEST METHODS.....	
13.3	TEST CONDITIONS .....	
13.4	SERIES 3 TYPE (a) TEST PRESCRIPTIONS .....	
13.4.1	Test 3 (a) (i) Bureau of Explosives impact machine (USA) .....	
13.4.2	<b>Test 3 (a) (ii) * BAM Fallhammer (D)</b> .....	
13.4.3	Test 3 (a) (iii) Rotter test (GB) .....	
13.4.4	Test 3 (a) (iv) 30 kg Fallhammer test (F).....	
13.4.5	Test 3 (a) (v) Modified type 12 impact tool (C) .....	
13.4.6	Test 3 (a) (vi) Impact sensitivity test (RUS) .....	
13.4.7	Test 3 (a) (vii) Modified Bureau of Mines impact machine test .....	
13.5	SERIES 3 TYPE (b) TEST PRESCRIPTIONS .....	
13.5.1	<b>Test 3 (b) (i) * BAM friction apparatus (D)</b> .....	
13.5.2	Test 3 (b) (ii) Rotary friction test (GB) .....	
13.5.3	Test 3 (b) (iii) Friction sensitivity test (RUS) .....	
13.5.4	Test 3 (b) (iv) ABL friction machine test .....	
13.6	SERIES 3 TYPE (c) TEST PRESCRIPTION .....	
13.6.1	<b>Test 3 (c) (i) * Thermal stability test at 75 °C (F/USA)</b> .....	
13.6.1	Test 3 (c) (ii) SBAT thermal stability test at 75 °C .....	
13.7	SERIES 3 TYPE (d) TEST PRESCRIPTION .....	
13.7.1	<b>Test 3 (d) * Small-scale burning test (F/USA)</b> .....	
<b>14.</b>	<b>TEST SERIES 4</b> .....	
14.1	INTRODUCTION .....	
14.2	TEST METHODS.....	
14.3	TEST CONDITIONS .....	
14.4	SERIES 4 TYPE (a) TEST PRESCRIPTIONS .....	
14.4.1	<b>Test 4 (a) * Thermal stability test for unpackaged articles and packaged articles (USA)</b> .....	
14.5	SERIES 4 TYPE (b) TEST PRESCRIPTIONS .....	
14.5.1	<b>Test 4 (b) (i) * The steel tube drop test for liquids (F)</b> .....	
14.5.2	<b>Test 4 (b) (ii) * Twelve metre drop test for unpackaged articles, packaged articles and packaged substances (USA)</b> .....	
<b>15.</b>	<b>TEST SERIES 5</b> .....	
15.1	INTRODUCTION .....	
15.2	TEST METHODS .....	
15.3	TEST CONDITIONS .....	
15.4	SERIES 5 TYPE (a) TEST PRESCRIPTION .....	
15.4.1	<b>Test 5 (a) * Cap sensitivity test (D/USA)</b> .....	
15.5	SERIES 5 TYPE (b) TEST PRESCRIPTIONS .....	
15.5.1	Test 5 (b) (i) French DDT test (F).....	
15.5.2	<b>Test 5 (b) (ii) * USA DDT test (USA)</b> .....	

CONTENTS OF PART I (continued)

15.5.3	Test 5 (b) (iii)	Deflagration to detonation transition test (RUS) .....
15.6	SERIES 5 TYPE (c) TEST PRESCRIPTION .....	
15.6.1	<b>Test 5 (c)* External fire test for Division 1.5 (UN)</b> .....	
<b>16.</b>	<b>TEST SERIES 6</b> .....	
16.1	INTRODUCTION .....	
16.2	TEST METHODS .....	
16.3	TEST CONDITIONS .....	
16.4	SERIES 6 TYPE (a) TEST PRESCRIPTION .....	
16.4.1	<b>Test 6 (a) * Single package test (UN)</b> .....	
16.5	SERIES 6 TYPE (b) TEST PRESCRIPTION .....	
16.5.1	<b>Test 6 (b) * Stack test (UN)</b> .....	
16.6	SERIES 6 TYPE (c) TEST PRESCRIPTION .....	
16.6.1	<b>Test 6 (c) * External fire (bonfire) test (UN)</b> .....	
16.7	SERIES 6 TYPE (d) TEST PRESCRIPTION .....	
16.7.1	<b>Test 6 (d) * Unconfined package test (UN)</b> .....	
<b>17.</b>	<b>TEST SERIES 7</b> .....	
17.1	INTRODUCTION .....	
17.2	TEST METHODS .....	
17.3	TEST CONDITIONS .....	
17.4	SERIES 7 TYPE (a) TEST PRESCRIPTION .....	
17.4.1	<b>Test 7 (a) * EIS cap test (D/USA)</b> .....	
17.5	SERIES 7 TYPE (b) TEST PRESCRIPTION .....	
17.5.1	<b>Test 7 (b) * EIS gap test (USA)</b> .....	
17.6	SERIES 7 TYPE (c) TEST PRESCRIPTIONS .....	
17.6.1	Test 7 (c) (i)	Susan impact test (USA).....
17.6.2	<b>Test 7 (c) (ii) * Friability test (F)</b> .....	
17.7	SERIES 7 TYPE (d) TEST PRESCRIPTIONS .....	
17.7.1	<b>Test 7 (d) (i) * EIS bullet impact test (USA)</b> .....	
17.7.2	Test 7 (d) (ii)	Friability test (F).....
17.8	SERIES 7 TYPE (e) TEST PRESCRIPTION .....	
17.8.1	<b>Test 7 (e) * EIS external fire test (UN)</b> .....	
17.9	SERIES 7 TYPE (f) TEST PRESCRIPTION .....	
17.9.1	<b>Test 7 (f) * EIS slow cook-off test (USA)</b> .....	
17.10	SERIES 7 TYPE (g) TEST PRESCRIPTION .....	
17.10.1	<b>Test 7 (g) * 1.6 Article (or component level) external fire test (UN)</b> .....	
17.11	SERIES 7 TYPE (h) TEST PRESCRIPTION .....	
17.11.1	<b>Test 7 (h) * 1.6 Article slow cook-off test (USA)</b> .....	
17.12	SERIES 7 TYPE (j) TEST PRESCRIPTION .....	
17.12.1	<b>Test 7 (j) * 1.6 Article bullet impact test (USA)</b> .....	
17.13	SERIES 7 TYPE (k) TEST PRESCRIPTION .....	
17.13.1	<b>Test 7 (k) * 1.6 Article stack test (UN)</b> .....	

CONTENTS OF PART I (continued)

17.14	SERIES 7 TYPE (I) TEST PRESCRIPTION .....
17.14.1	<b>Test 7 (I):</b> * <b>1.6 Article (or component level) fragment impact test</b> .....
<b>18.</b>	<b>TEST SERIES 8</b> .....
18.1	INTRODUCTION .....
18.2	TEST METHODS .....
18.3	TEST CONDITIONS .....
18.4	SERIES 8 TYPE (a) TEST PRESCRIPTION .....
18.4.1	<b>Test 8 (a):</b> * <b>Thermal stability test for ammonium nitrate emulsions, suspensions or gels</b> .....
18.5	SERIES 8 TYPE (b) TEST PRESCRIPTION .....
18.5.1	<b>Test 8 (b):</b> * <b>ANE Gap Test</b> .....
18.6	SERIES 8 TYPE (c) TEST PRESCRIPTION .....
18.6.1	<b>Test 8 (c):</b> * <b>Koenen test</b> .....
18.7	SERIES 8 TYPE (d) TEST PRESCRIPTIONS .....
18.7.1	<b>Test 8 (d) (i):</b> * <b>Vented pipe test</b> .....
18.7.2	<b>Test 8 (d) (ii):</b> * <b>Modified vented pipe test</b> .....

---

## SECTION 10

### INTRODUCTION TO PART I

#### 10.1 Purpose

10.1.1 Part I of the Manual presents the United Nations scheme for the classification of explosives. It includes a description of the procedures and test criteria considered to be the most useful for providing competent authorities with the necessary information to arrive at a proper classification of explosive substances and articles ~~for transport~~. It should be used in conjunction with the classification flow charts in figures 10.1, 10.2, 10.3, 10.4 and 10.5, the general conditions for testing in sub-section 1.5 and the appropriate test prescriptions in sections 11 to 18 of this Manual.

10.1.2 ~~Goods of Class 4 Explosives, other than unstable explosives~~, are assigned to one of six divisions, depending on the type of hazard they present (see [Chapter 2.1](#), paragraph 2.1.1.4 of the Model Regulations [and Chapter 2.1, paragraph 2.1.2 of the GHS](#)); and, ~~for some regulatory purposes (e.g. transport)~~, to one of [the](#) thirteen compatibility groups ~~which that~~ identify the kinds of explosives ~~substances and articles~~ that are deemed to be compatible. The general scheme for classifying a substance or article which is to be considered for inclusion in [the class of explosives Class 4](#) is illustrated in Figure 10.1. The assessment is in two stages. In the first stage, the potential of a substance or article to explode ~~should be~~ ascertained and its stability and sensitivity, both chemically and physically, ~~shown to be acceptable are also determined~~. In order to promote uniform assessments by competent authorities, it is recommended that, using the flow chart in Figure 10.2, data from suitable tests is analyzed systematically with respect to the appropriate test criteria. If the substance or article is provisionally accepted into [the class of explosives Class 4](#), it is then necessary to proceed to the second stage and assign it to the correct division by use of the flow chart of Figure 10.3 [and 10.5](#). With the exception of Compatibility Groups N and S, for which test data is necessary, assignment to a compatibility group, ~~when required~~, is usually made without reference to testing. In the case of Compatibility Group S, the tests may be waived by the competent authority if classification by analogy is based on test results for a comparable article.

10.1.3 The test procedures allow assessment of the hazard of explosive substances and articles so that an appropriate classification ~~for transport~~ can be ~~made assigned~~. ~~When appropriate this is done~~ by the competent authority.

#### 10.2 Scope

10.2.1 New products which are considered as having explosive properties or are intended to function as explosives should first be considered for inclusion in [the class of explosives Class 4](#). For substances such as self-reactive substances ~~of Division 4.1~~ or organic peroxides ~~of Division 5.2~~, refer to Part II of this Manual. In this context a new product is one which, in the opinion of the competent authority, involves any of the following:

- (a) A new substance ~~or a combination or mixture of substances~~, intended to function as an explosive or pyrotechnic, which is considered to be significantly different from other ~~combinations or mixtures~~ substances already classified;
- (b) A new substance ~~or article~~, not intended for explosive use, which has, or is suspected of having, explosive properties (see [Chapter 2.1](#), paragraph [2.1.3.1.25](#) of the Model Regulations [and Chapter 2.1, paragraph 2.1.1.2 of the GHS](#));

**Note by the secretariat:** *The reference in the list amendments reads: "2.1.3.1". The Sub-Committee is invited to confirm the correct reference to be used.*

- (c) A new design of article containing an explosive substance or an article containing a new explosive substance ~~or a new combination or mixture of explosive substances~~; or
- (d) A new design of package for an explosive substance or article including a new type of inner packaging or a new arrangement of articles. (A relatively minor change to an inner or outer packaging can be critical and can convert a lesser ~~risk hazard~~ into a mass explosion ~~risk hazard or vice versa~~).

~~The classification procedure should be undertaken before a new product is offered for transport.~~

10.2.2 The producer, or other applicant for the classification of a new product, should provide adequate information concerning the names and characteristics of all explosive substances in the product and should furnish the results of all relevant tests which have been done.

### 10.3 Acceptance procedure

#### 10.3.1 *General description*

10.3.1.1 The acceptance procedure is used to determine whether or not a ~~substance or article~~~~product as offered for transport~~ is a candidate for ~~the class of explosives Class 1~~. This is decided by determining whether a substance provisionally accepted ~~into the class of explosives for Class 1~~ is either too insensitive for inclusion in ~~the class of explosives Class 1~~ or ~~is accepted as an unstable explosive (and considered too dangerous for transport)~~; or whether article(s) or packaged article(s) are ~~accepted as an unstable explosive (and considered too dangerous for transport)~~.

#### 10.3.2 *Test types*

10.3.2.1 The test methods used for deciding provisional acceptance into ~~the class of explosives Class 1~~ are grouped into four series, numbered 1 to 4, and designed to provide the information necessary to answer the questions in Figure 10.2.

10.3.2.2 The question "Is it an explosive substance?" (box 4, Figure 10.2) is answered on the basis of national and international definitions of an explosive substance and the results of three types of Series 1 tests to assess possible explosive effects. The three types of test used are:

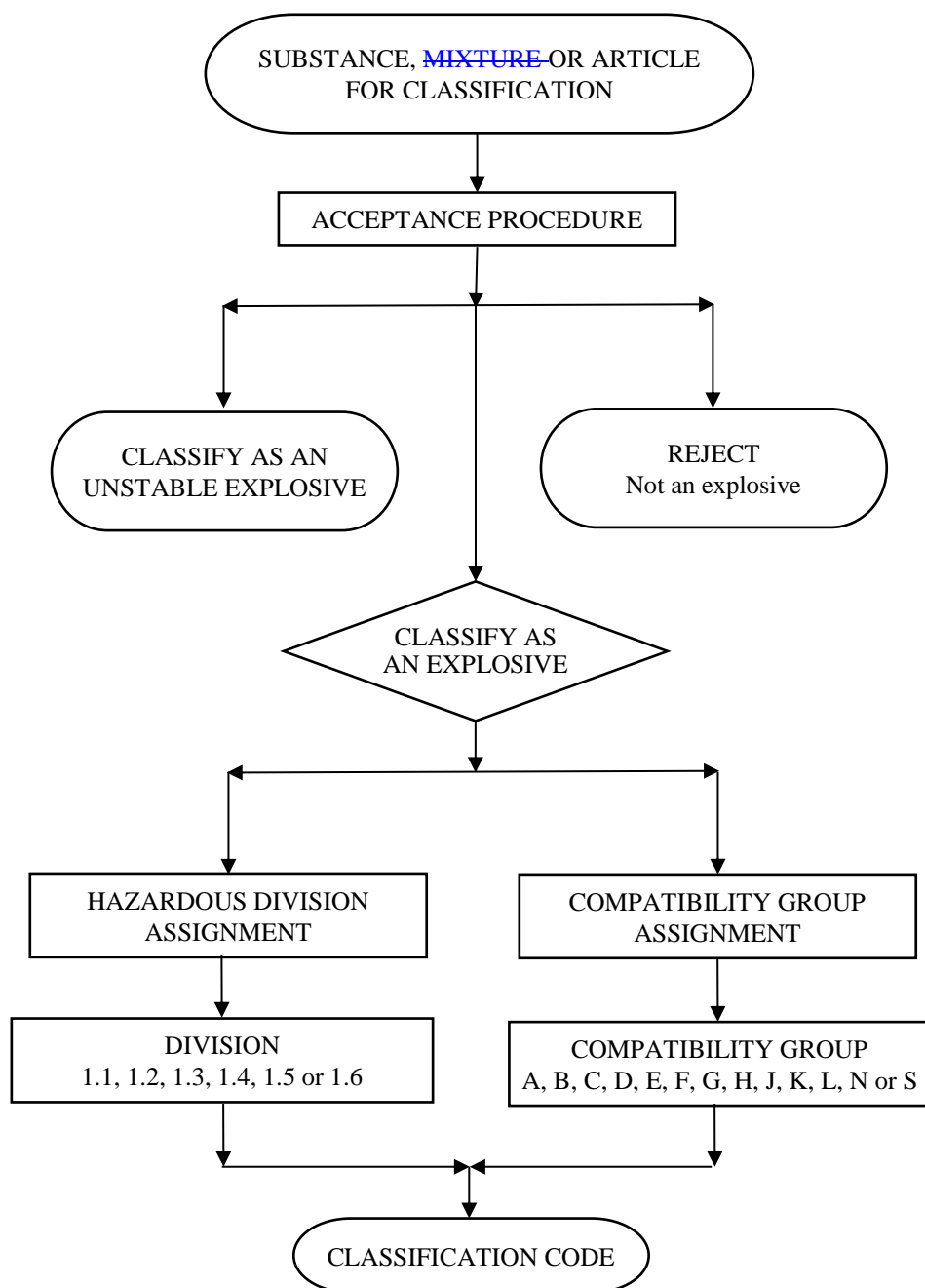
- Type 1 (a): a shock test with defined booster and confinement to determine the ability of the substance to propagate a detonation;
- Type 1 (b): a test to determine the effect of heating under confinement; and
- Type 1 (c): a test to determine the effect of ignition under confinement.

10.3.2.3 Series 2 tests are used to answer the question "Is the substance too insensitive for acceptance into ~~the class of explosives Class 1~~?" (box 6, Figure 10.2). In general the basic apparatus used is the same as that for Test Series 1 but with less stringent criteria, e.g. in the case of gap tests, the gap used is greater than zero. The following three types of test are used:

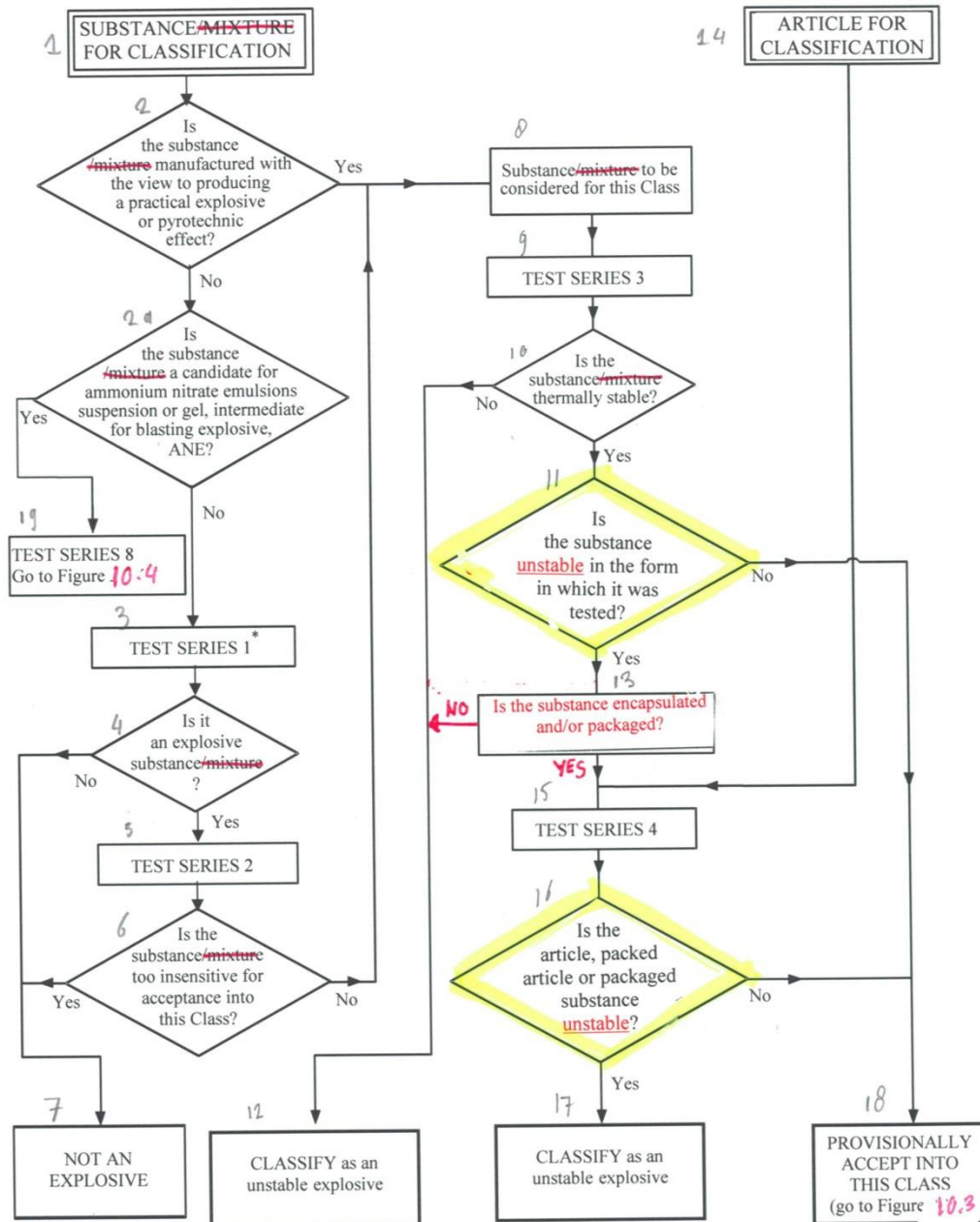
- Type 2 (a): a shock test with defined initiation system and confinement to determine sensitivity to shock;
- Type 2 (b): a test to determine the effect of heating under confinement; and
- Type 2 (c): a test to determine the effect of ignition under confinement.



Figure 10.1: OVERALL SCHEME OF THE PROCEDURE FOR CLASSIFYING A SUBSTANCE OR ARTICLE IN THE CLASS OF EXPLOSIVES



**Figure 10.2: PROCEDURE FOR PROVISIONAL ACCEPTANCE OF A SUBSTANCE OR ARTICLE INTO THE CLASS OF EXPLOSIVES-4**



\* For classification purposes, start with test series 2.

10.3.2.4 Test series 3 is used to answer the questions "Is the substance thermally stable?" (box 10, Figure 10.2) and "Is the substance ~~too dangerous for transport unstable~~ in the form in which it was tested?" (box 11, Figure 10.2). This involves tests for determining the sensitiveness of the substance to mechanical stimuli (impact and friction), and to heat and flame. The following four types of test are used:

- Type 3 (a): a falling weight test to determine sensitiveness to impact;
- Type 3 (b): a friction, or impacted friction, test to determine sensitiveness to friction;
- Type 3 (c): an elevated temperature test to determine thermal stability; and
- Type 3 (d): an ignition test to determine the response of a substance to fire.

10.3.2.5 Series 4 tests are intended to answer the question "Is the article, packaged article or packaged substance ~~too dangerous for transport unstable~~?" (box 16, Figure 10.2). Typical conditions which may ~~occur during transport be encountered~~ include high temperature and high relative humidity, low temperature, vibration, bumping and dropping. The two types of test to be carried out are:

- Type 4 (a): a test of thermal stability for articles; and
- Type 4 (b): a test to determine the hazard from dropping.

### 10.3.3 *Application of the test methods*

10.3.3.1 The numbering of test series 1 to 4 relates to the sequence of assessing the results rather than the order in which the tests are conducted. ***It may be important for the safety of experimenters that certain preliminary tests, using small amounts of material, be conducted first before proceeding to experiment with larger quantities.*** The results of these preliminary tests may also be used in the classification procedure.

**10.3.3.2** The acceptance procedure for substances designed to have an explosive effect starts with the application of test types 3 (a), 3 (b), 3 (c) and 3 (d) to determine if the substance is too sensitive for transport in the form tested. If it proves to be thermally unstable, i.e. it fails test type 3 (c), it is not permitted to be transported. If it fails test types 3 (a), 3 (b) or 3 (d) it may either be encapsulated or otherwise desensitized or packaged to reduce its sensitiveness to external stimuli. Examples are water-wetted primary explosives and primary explosives which have been encapsulated in the form of detonators. The resulting new articles should be submitted to test series 4, and liquids or packaged solids to a test of type 4 (b), to determine whether or not their level of safety in transport is consistent with the requirements of Class 1. Desensitized substances should be re-examined under test series 3 for the same purpose. If a substance designed to have an explosive effect passes all tests in series 3 or an article designed to have an explosive effect passes all tests in series 4, the procedure for assignment to the appropriate division is applied.

**10.3.3.3** Although test series 1 indicates whether a substance, not designed to have an explosive effect, has in fact potentially explosive properties, again it is more appropriate to start the testing procedure with test series 3. These tests involve relatively small sample sizes, which reduces the risk to test personnel. If test series 3 indicates that a substance is too sensitive for transport in the form in which it is tested, then the procedures for reducing its sensitiveness to external stimuli, outlined in 10.3.3.2, should be applied. If test series 3 indicates that the substance is not too sensitive for transport, the next step is the application of test series 2 which determines whether the substance is too insensitive for inclusion in Class 1. There is no real need to perform test series 1 at this point in the acceptance procedure since test series 2 answers the pertinent question regarding the degree of insensitiveness of the substance. Test series 1 is concerned with the resolution of questions relating to the explosive nature of the substance. The procedure for assignment to a division of Class 1 should be applied to substances which fail test series 2 but pass test series 3 i.e. they are not too insensitive for acceptance into Class 1 nor are they thermally unstable or too dangerous to transport in the form in which they are tested. It is important to note that a substance which fails test series 2 may still, if properly packaged, leave Class 1 provided that the product is not designed to have an explosive effect and does not exhibit any explosive hazard in test series 6 of the assignment procedure.

**10.3.3.4** All articles or packaged articles containing substances which have failed test type 3 (a), 3 (b) or 3 (d) should be subjected to test series 4. If the article or packaged articles pass test type 4 (a), test type 4 (b) is performed. Packaged substances are subjected to test type 4 (b) only. If the product fails either test type 4 (a) or 4 (b), it should be rejected. However, the product may be modified and re-tested. If the competent authority suspects that the product may be subject to stimuli other than those specified in test type 4 (a) and 4 (b) resulting in potentially dangerous effects, additional information or tests may be required (see note under paragraph 2.1.3.3.1 of the Model Regulations).

10.3.3.5 If articles contain expensive, inert, control components, [for testing purposes](#) these may be replaced by inert components having a similar mass and volume.

## 10.4 Procedure for assignment to a division of [the class of explosives](#)~~Class 1~~

### 10.4.1 *General description*

10.4.1.1 ~~Goods of Class 1~~[Unless classified as unstable explosives](#) are assigned to one of six divisions, depending on the type of hazard they present (see paragraph 2.1.1.4 of the Model Regulations [and 2.1.2 of the GHS](#)). The assignment procedure (Figure 10.3 [and 10.5](#)) applies to all substances and/or articles that are candidates for [this class](#)~~Class 1~~ except those declared from the outset to be in Division 1.1. A substance or article ~~is should be~~ assigned to the division which corresponds to the results of the tests to which ~~it the substance or article, as offered for transport,~~ has been subjected. Other test results, and data assembled from accidents which have occurred, may also be taken into account. As indicated in box 36 of Figure 10.3, there is authority to exclude an article from ~~Class 1~~[the class of explosives](#) by virtue of test results and the ~~Class 1~~[“explosives”](#) definition ([see paragraph 2.1.1.1\(b\) of the Model Regulations and paragraph 2.1.1.2 \(b\) of the GHS](#)). [Specific criteria by which articles may be excluded from the class of explosives \(for transport\) may be found in the Model Regulations \(see paragraph 2.1.3.6.4\).](#)

**Note by the secretariat:** *The secretariat notes that the reference “(for transport)” is missing in the list of amendments. The Sub-Committee is invited to clarify whether this text should be kept or deleted.*

**Note by the secretariat:** *The secretariat notes that the reference “(for transport)” is missing in the list of amendments. The Sub-Committee is invited to clarify whether this text should be kept or deleted.*

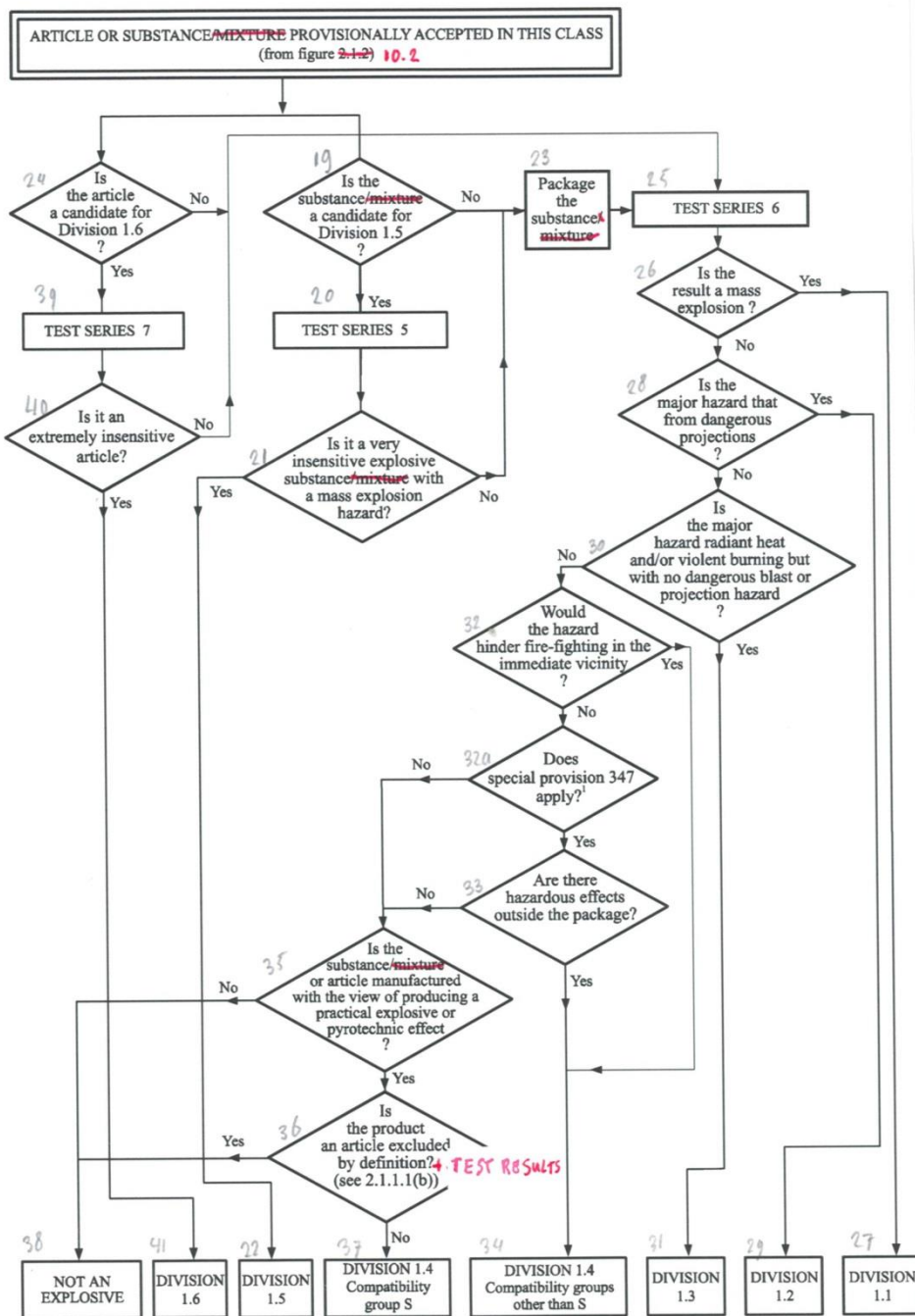
### 10.4.2 *Test types*

10.4.2.1 The test methods used for assignment to a division are grouped into three series - numbered 5 to 7 - designed to provide the information necessary to answer the questions in Figure 10.3. The tests in series 5, 6 and 7 should not be varied unless the ~~national~~[competent](#) authority is prepared to justify such action internationally.

10.4.2.2 The results from three types of series 5 tests are used to answer the question "Is it a very insensitive explosive substance with a mass explosion hazard?" (box 21, Figure 10.3). The test types are:

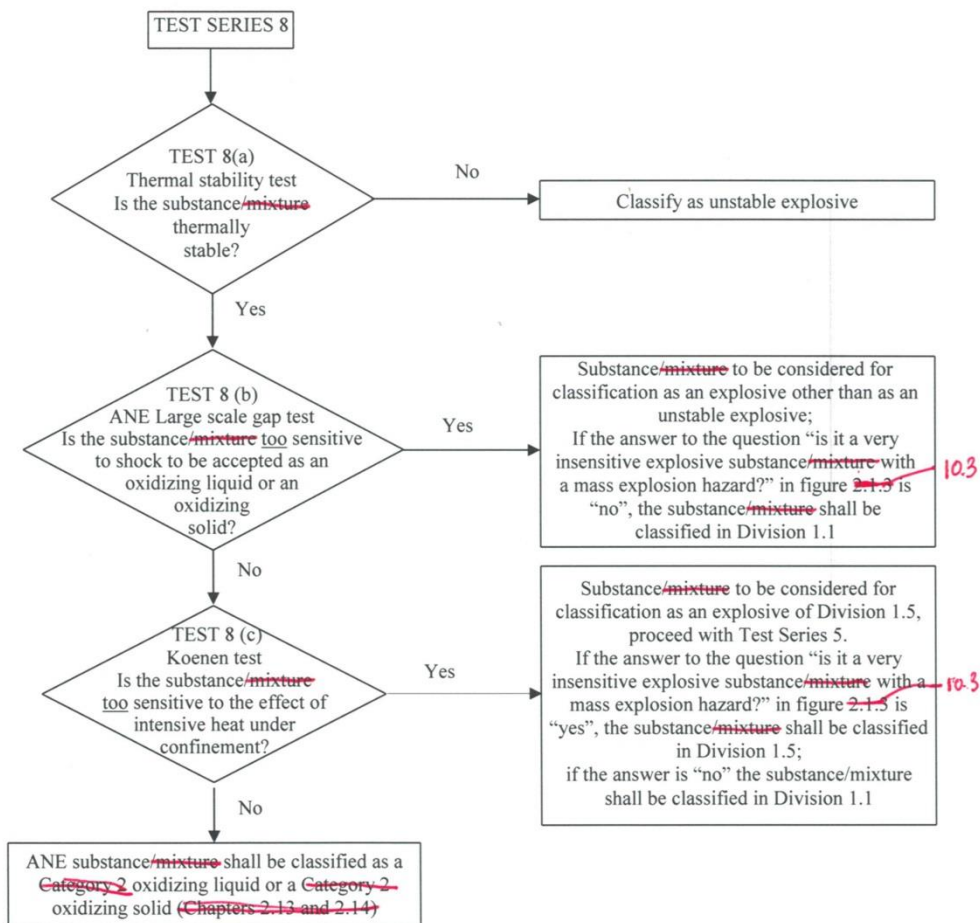
- Type 5 (a): a shock test to determine the sensitivity to intense mechanical stimulus;
- Type 5 (b): thermal tests to determine the tendency for transition from deflagration to detonation;  
and
- Type 5 (c): a test to determine if a substance, when in large quantities, explodes when subjected to a large fire.

Figure 10.3: PROCEDURE FOR ASSIGNMENT TO A DIVISION OF THE CLASS OF EXPLOSIVES

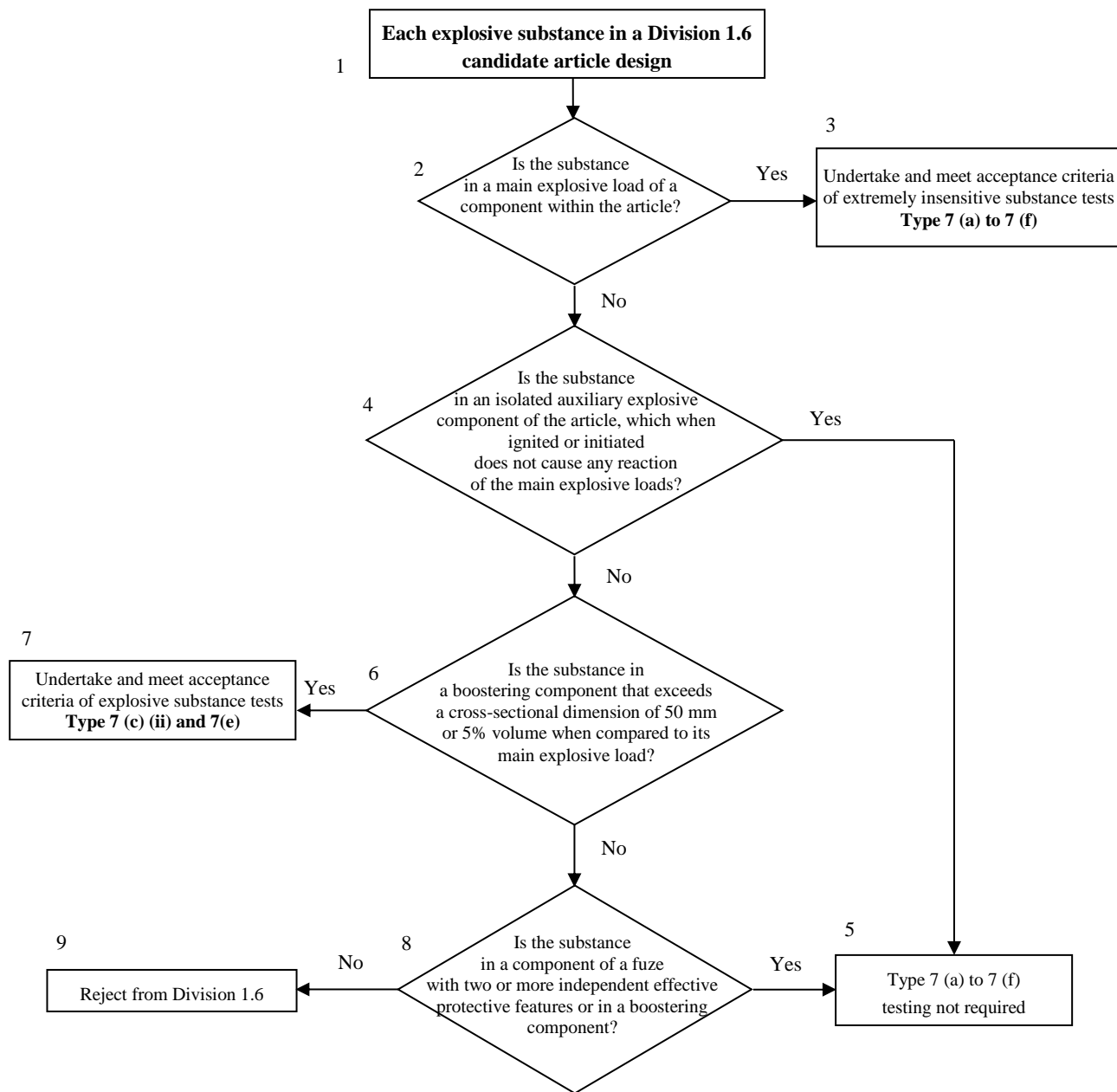


**Figure 10.4: PROCEDURE FOR AMMONIUM NITRATE EMULSION, SUSPENSION OR GEL, INTERMEDIATE FOR BLASTING EXPLOSIVES**

10.4



**Figure 10.5: PROCEDURE TO DETERMINE REQUIRED SUBSTANCE TESTING FOR DIVISION 1.6**



10.4.2.3 The results from four types of series 6 tests, as appropriate, are used to determine which division, amongst Divisions 1.1, 1.2, 1.3 and 1.4, corresponds most closely to the behaviour of a product in a certain configuration if ~~a load is it is~~ involved in a fire resulting from internal or external sources or an explosion from internal sources (boxes 26, 28, 30, 32, 32a and 33 of Figure 10.3). The results are also necessary to assess whether a product in a certain configuration can be assigned to Compatibility Group S of Division 1.4 and whether or not it ~~should can~~ be excluded from the class of explosives Class 1 (boxes 35 and 36 of Figure 10.3). The four types of test are:

- Type 6 (a): a test on a single package to determine if there is mass explosion of the contents;
- Type 6 (b): a test on packages of an explosive substance or explosive articles, or non-packaged explosive articles, to determine whether an explosion is propagated from one package to another or from a non-packaged article to another;
- Type 6 (c): a test on packages of an explosive substance or explosive articles, or non-packaged explosive articles, to determine whether there is a mass explosion or a hazard from dangerous projections, radiant heat and/or violent burning or any other dangerous effect when involved in a fire; and
- Type 6 (d): a test on an unconfined package of explosive articles to which special provision 347 of Chapter 3.3 of the Model Regulations applies, to determine if there are hazardous effects outside the package arising from accidental ignition or initiation of the contents.

10.4.2.4 The question "Is it an extremely insensitive explosive article?" (box 40, Figure 10.3) is answered by series 7 tests and any candidate for Division 1.6 ~~should shall~~ pass one of each of the eleven types of test comprising the series. The protocol for determining the test requirements is given in Figure 10.5. The first six types of test (7(a) to 7(f)) are used to establish if a substance is an Extremely Insensitive Substance (EIS). The purpose of these tests is to develop an understanding of the sensitivity of substance(s) contained within the article, which informs and provides confidence in the article tests. The remaining five types of test (7(g), 7(h), 7(j), 7 (k) and 7 (l)) are used to determine if an article predominantly containing an EIS may be assigned to Division 1.6. The eleven test types are:

- Type 7 (a): a shock test to determine the sensitivity to intense mechanical stimulus;
- Type 7 (b): a shock test with a defined booster and confinement to determine the sensitivity to shock;
- Type 7 (c): a test to determine the sensitivity of the explosive substance to deterioration under the effect of an impact;
- Type 7 (d): a test to determine the degree of reaction of the explosive substance to impact or penetration resulting from a given energy source;
- Type 7 (e): a test to determine the reaction of the explosive substance to an external fire when the material is confined;
- Type 7 (f): a test to determine the reaction of the explosive substance in an environment in which the temperature is gradually increased to 365 °C;
- Type 7 (g): a test to determine the reaction to an external fire of an article which is in the condition as presented for transport classification;
- Type 7 (h): a test to determine the reaction of an article in an environment in which the temperature is gradually increased to 365 °C;
- Type 7 (j): a test to determine the reaction of an article to impact or penetration resulting from a given energy source;
- Type 7 (k): a test to determine whether the detonation of an article will initiate a detonation in an adjacent, like, article; and
- Type 7 (l): a test to determine the sensitivity of an article to shock directed at vulnerable components.

10.4.2.5 The question "Is the substance a candidate for "ammonium nitrate emulsion or suspension or gel, intermediate for blasting explosives (ANE)?" (box 2(a), Figure 10.2) is answered by series 8 tests and any candidate should pass each of the three tests comprising the series. The three test types are:



- Type 8 (a): a test to determine the thermal stability;  
Type 8 (b): a shock test to determine sensitivity to intense shock;  
Type 8 (c): a test to determine the effect of heating under confinement;

Test series 8 (d) has been included in this section as one method to evaluate the suitability of ANEs for ~~the~~ [transport/containment](#) in portable tanks [as an oxidizing substance](#).

### 10.4.3 *Application of the test methods*

10.4.3.1 Explanations of certain terms used in the assignment of divisions and compatibility groups are given in the Glossary in Appendix B of the Model Regulations (e.g. mass explosion, pyrotechnic substance, entire load, total contents, explode, explosion of the total contents).

10.4.3.2 Test series 5 should be used to determine whether a substance can be assigned to Division 1.5. Only those substances which pass all three types of test may be assigned to Division 1.5.

10.4.3.3 Test series 6 should be applied to packages of explosive substances and articles in the condition and form in which they are offered for [transport/classification](#). The geometrical arrangement of the products should be realistic in regard to the packing method, ~~and the conditions of transport~~, and should be such as to produce the most ~~disadvantageous-severe~~ test results. Where explosive articles are [to be carried classified](#) without packaging, the tests should be applied to the non-packaged articles. All types of packaging containing substances or articles should be subjected to the tests unless:

- (a) The product, including any packaging, can be unambiguously assigned to a division by the competent authority on the basis of results from other tests or of available information; or
- (b) The product, including any packaging, is assigned to Division 1.1.

10.4.3.4 Test types 6 (a), 6 (b), 6 (c) and 6 (d) are normally performed in alphabetical order. However, it is not always necessary to follow this order or to conduct all four types of test.

- (a) Test type 6 (a) may be waived if explosive articles are [carried-classified](#) without packaging or when only one article is in the package, (see also section 10.4.3.4.(d));
- (b) Test type 6 (b) may be waived if, in each type of 6 (a) test, (see also section 10.4.3.4 (d))
  - (i) The exterior of the package is undamaged by internal ~~detonation—and/or~~ [ignition/initiation](#); or
  - (ii) The contents of the package fail to explode, or explode so feebly as would exclude propagation of the explosive effect from one package to another in test type 6 (b).
- (c) Test type 6 (c) may be waived if, in a type 6 (b) test, there is a practically instantaneous explosion of virtually the total contents of the stack. In such cases the product is assigned to Division 1.1.
- (d) Test type 6 (d) is a test used to determine whether a 1.4S classification is appropriate and is only used if special provision 347 of Chapter 3.3 of the Model Regulations applies. When testing articles to which special provision 347 applies, test type 6 (d) may be performed first. If the results of test type 6(d) indicate that a 1.4S classification is appropriate, then test types 6 (a) and 6 (b) may be waived.

10.4.3.5 If a substance gives a "-" result (no propagation of detonation) in the Series 1 type (a) test, the 6 (a) test with a detonator may be waived. If a substance gives a "-" result (no or slow deflagration) in a Series 2 type (c) test, the 6 (a) test with an igniter may be waived.

10.4.3.6 Tests types 7 (a) to 7 (f) ~~should be~~ used to establish that ~~the an~~ explosive is an extremely insensitive ~~detonating~~ substance and then test types 7 (g), 7 (h), 7 (j), 7 (k) and 7 (l) ~~are~~ used to establish that ~~the~~ articles ~~predominantly~~ containing EIS(s) may be assigned to Division 1.6.

10.4.3.7 Tests of types 7 (g), 7 (h), 7 (j), 7 (k) and 7(l) ~~should be~~ performed to determine if an article with EIS main explosive load(s) and appropriately insensitive boosting components may be assigned to Division 1.6. These tests are applied to articles in the condition and form in which they are offered for ~~transport~~ classification, except that non-explosive components may be omitted or simulated if the competent authority is satisfied that this does not invalidate the results of the tests. The procedure detailing testing requirements is given in Figure 10.5 and some points of explanation are given below.

- (a) Complex articles may contain multiple substances and ~~test types 7(a) to (f) shall this procedure should~~ be completed for all ~~main explosive load and boosting component~~ substances, ~~as appropriate~~, within the article to be classified ~~in Division 1.6~~.
- (b) The question "Is the substance in a main explosive load of a component within the article?" (Box 2 of Figure 10.5) is answered by examining the design of the article. Main explosive load substances are those loaded into components within the article that are not fuze, boosting, or isolated auxiliary explosive components. All substances in main explosive loads must "Undertake and meet acceptance criteria of extremely insensitive substance tests, Type 7 (a) to 7 (f)" (Box 3 of Figure 10.5). If a '+' result is obtained for any main explosive load substance to any Type 7 (a) to 7 (f) test, the substance is not an EIS and the answer to the question in Box 24 of Figure 10.3 is "No". The article is not a candidate for Division 1.6.
- (c) Answering the question "Is the substance in an isolated auxiliary explosive component of the article, which when ignited or initiated does not cause any reaction of the main explosive loads?" (Box 4 of Figure 10.5) requires knowledge of the design of the article plus the explosive effects that occur when such components are initiated or ignited, either in their design mode or accidentally. Typically these will be small explosive actuators or pyromechanical devices that produce movement, cutting or opening functions. If the answer is 'yes' to this question, Type 7 (a) to 7 (f) testing is not required for substances in isolated auxiliary explosive components and the article remains a candidate for Division 1.6.
- (d) The question "Is the substance in a boosting component that exceeds a cross-sectional dimension of 50 mm or 5% volume when compared to its main explosive load?" (Box 6 of Figure 10.5) is answered by examining the design of the article. All substances in such larger boosting components, including those contained in explosive components of dual-protected fuzes in an article, must "Undertake and meet acceptance criteria of explosive substance tests, Type 7 (c) (ii) and 7 (e)" (box 7 of Figure 10.5). If a '+' result is obtained for any such larger boosting component substance to either Type 7 (c) (ii) and 7 (e) tests, the answer to the question in Box 24 of Figure 10.3 is "No". The article is not a candidate for Division 1.6.

- (e) The question "Is the substance in a component of a fuze with two or more independent effective protective features or in a boosting component" (Box 8 of Figure 10.5) is answered by an understanding of the design and development of the article. If the answer is 'no', the article is not considered to have suitable intrinsic safety characteristics and the answer to the question in Box 24 of Figure 10.3 is 'No' the article is not a candidate for Division 1.6.

*NOTE: Knowledge of the design and explosive effects can be obtained by modelling or indicative tests etc.*

10.4.3.8 Test types 8 (a) to 8 (c) should be used to establish whether an ammonium nitrate emulsion or suspension or gel, intermediate for blasting explosives (ANE) may be ~~assigned to Division 5.1~~ accepted as an oxidizing solid or liquid. Substances failing any of the tests may be considered as a candidate for the class of explosives Class 1 in accordance with Figure 10.4.

~~10.4.3.9 If articles contain expensive, inert, control components, these may be replaced by inert components having a similar mass and volume.~~

## **10.5 Examples of test reports**

10.5.1 Examples of test reports, with an illustration of the use of the flow charts on the application of the ~~class of explosives Class 1~~ acceptance and assignment procedures to ~~musk xylene (UN 2956)~~ hexanitrostilbene (UN0392), are given in figures 10.6 to 10.9.

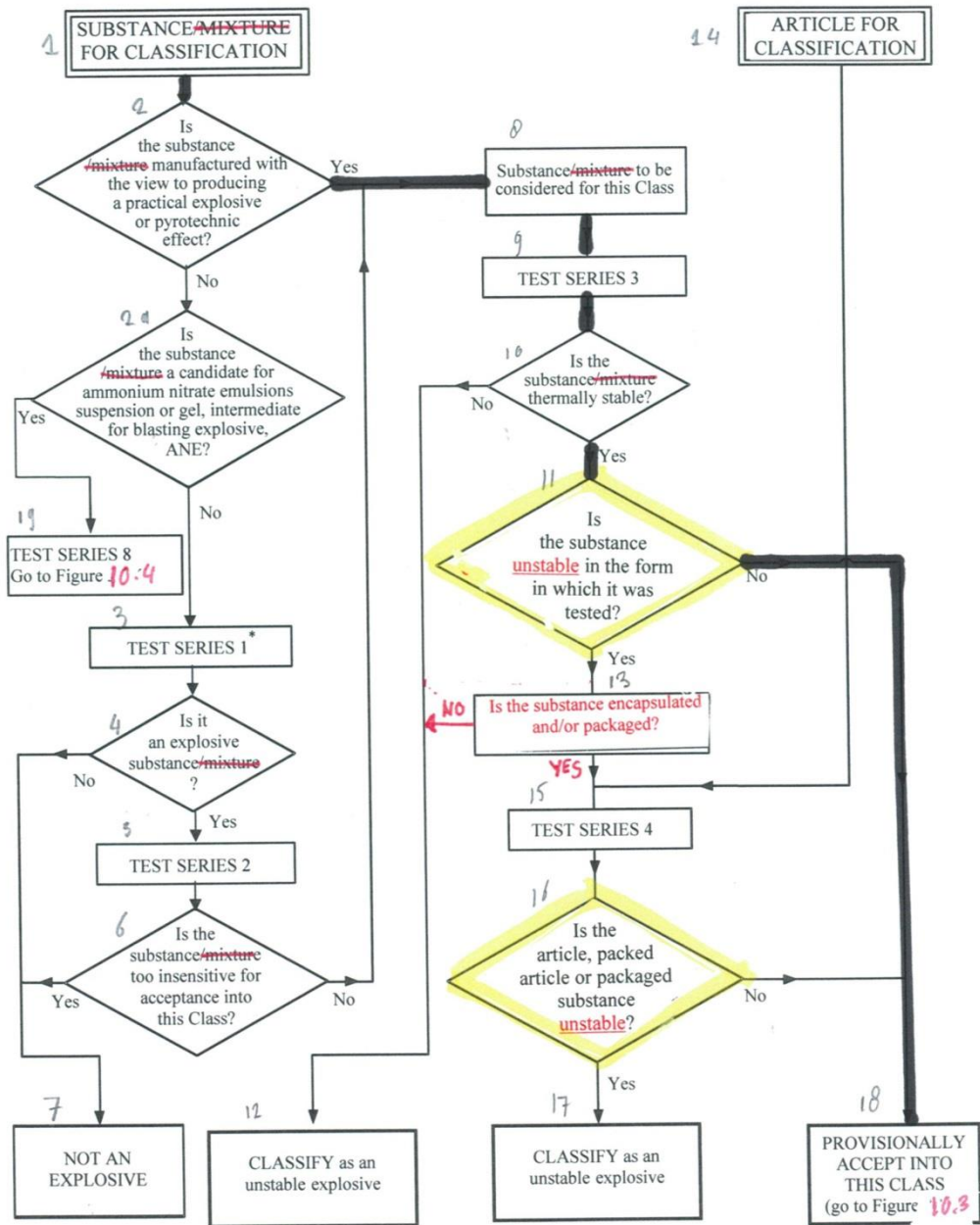
10.5.2 An example proforma for a test report on articles is given in Figure 10.10.

**Figure 10.6: RESULTS FROM APPLICATION OF THE CLASS 1—OF EXPLOSIVES ACCEPTANCE PROCEDURE**

- 1. Name of substance:** [Hexanitrostilbene](#)5 tert-BUTYL-2,4,6-TRINITRO-m-XYLENE (MUSK-XYLENE)
- 2. General data**
- 2.1 Composition: [hexanitrostilbene](#)99% tert-butyl-2,4,6-trinitro-m-xylene
- 2.2 Molecular formula: [C<sub>14</sub>H<sub>6</sub>N<sub>6</sub>O<sub>12</sub>](#)C<sub>12</sub>H<sub>15</sub>N<sub>3</sub>O<sub>6</sub>
- 2.3 Physical form: [Fine-crystalline](#) powder
- 2.4 Colour: [Pale-yellow](#) [orange](#)
- 2.5 Apparent density: [840-1700](#) kg/m<sup>3</sup>
- 2.6 Particle size: [0.1 – 0.3](#)<[1.7](#) mm
- 3. Box 2:** Is the substance manufactured with the view to producing a practical explosive or pyrotechnic effect?
- 3.1 Answer: [No](#)[Yes](#)
- 3.2 Exit: Go to Box [38](#)
- 4.—Box 3:** [Test Series 1](#)
- 4.1—Propagation of Detonation: [UN-gap test \(test 1\(a\)\)](#)
- 4.2—Sample conditions: [Ambient temperature](#)
- 4.3—Observations: [Fragmentation length 40 cm](#)
- 4.4—Result: [" + ", propagation of detonation](#)
- 4.5—Effect of heating under confinement: [Koenen test \(test 1\(b\)\)](#)
- 4.6—Sample conditions: [Mass 22.6 g](#)
- 4.7—Observations: [Limiting diameter 5.0 mm](#)  
[Fragmentation type "F" \(time to reaction 52 s, duration of reaction 27 s\)](#)
- 4.8—Result: [" + ", shows some explosive effects on heating under confinement](#)
- 4.9—Effect of ignition under confinement: [Time/pressure test \(test 1 \(c\) \(i\)\)](#)
- 4.10—Sample conditions: [Ambient temperature](#)
- 4.11—Observations: [No ignition](#)
- 4.12—Result: [" ", no effect on ignition under confinement](#)
- 4.13—Exit: [Go to Box 4](#)
- 5.—Box 4:** [Is it an explosive substance?](#)
- 5.1—Answer from Test Series 1: [Yes](#)
- 5.2—Exit: [Go to box 5](#)
- 6.—Box 5:** [Test Series 2](#)
- 6.1—Sensitivity to shock: [UN-gap test \(test 2\(a\)\)](#)
- 6.2—Sample conditions: [Ambient temperature](#)
- 6.3—Observations: [No propagation](#)
- 6.4—Result: [" ", not sensitive to shock](#)
- 6.5—Effect of heating under confinement: [Koenen test \(test 2\(b\)\)](#)
- 6.6—Sample conditions: [Mass 22.6 g](#)
- 6.7—Observations: [Limiting diameter 5.0 mm](#)  
[Fragmentation type "F" \(time to reaction 52 s, duration of reaction 27 s\)](#)
- 6.8—Result: [" + ", violent effect on heating under confinement](#)

<del>6.9</del>	<del>Effect of ignition under confinement:</del>	<del>Time/pressure test (test 2 (c) (i))</del>
<del>6.10</del>	<del>Sample conditions:</del>	<del>Ambient temperature</del>
<del>6.11</del>	<del>Observations:</del>	<del>No ignition</del>
<del>6.12</del>	<del>Result:</del>	<del>"", no effect on ignition under confinement</del>
<del>6.13</del>	<del>Exit:</del>	<del>Go to Box 6</del>
<del>7.</del>	<del>Box 6:</del>	<del>Is the substance too insensitive for acceptance into Class 1?</del>
<del>7.1</del>	<del>Answer from Test Series 2:</del>	<del>No</del>
<del>7.2</del>	<del>Conclusion:</del>	<del>Substance to be considered for Class 1 (box 8)</del>
<del>7.3</del>	<del>Exit:</del>	<del>Go to Box 9</del>
<b>4.</b>	<b>Box 8:</b>	<b><u>Substance to be considered for the class of explosives</u></b>
<b>85.</b>	<b>Box 9:</b>	Test Series 3
85.1	Thermal stability:	75 °C/48 hour test (test 3 (c))
85.2	Sample conditions:	100 g of substance at 75 °C
85.3	Observations:	No ignition, explosion, self-heating or visible decomposition
85.4	Result:	"", thermally stable
85.5	Impact sensitivity:	BAM fallhammer test (test 3 (a) (ii))
85.6	Sample conditions:	as received
85.7	Observations:	Limiting impact energy <u>25 J</u>
85.8	Result:	<u>"", not unstable in form tested"</u> , <del>not too dangerous to transport in form tested</del>
85.9	Friction sensitivity:	BAM friction test (test 3 (b) (i))
85.10	Sample conditions:	as received
85.11	Observations:	Limiting load > <u>240 360 N</u>
85.12	Result:	<u>"", not unstable in form tested"</u> , <del>not too dangerous to transport in form tested</del>
85.13	Ease of deflagration to detonation transition	Small scale burning test (test 3 (d))
85.14	Sample conditions:	Ambient temperature
85.15	Observations:	Ignites and burns <u>slowly</u>
85.16	Result:	<u>"", not unstable in the form in which it was tested"</u> , <del>not too dangerous to transport in form tested</del>
85.17	Exit:	Go to box 10
<b>96.</b>	<b>Box 10:</b>	Is the substance thermally stable?
96.1	Answer from test 3(c):	Yes
96.2	Exit:	Go to box 11
<b>107.</b>	<b>Box 11:</b>	Is the substance <del>too dangerous for transport</del> <u>unstable</u> in the form in which it was tested?
<del>740.1</del>	<del>Answer from Test Series 3:</del>	<del>No</del>
<del>107.2</del>	<del>Exit:</del>	<del>Go to box 18</del>
<b>118.</b>	<b>Conclusion:</b>	PROVISIONALLY ACCEPT INTO <u>THE CLASS 4 OF EXPLOSIVES</u>
118.1	Exit:	Apply <del>the Class 1</del> assignment procedure <u>for the class of explosives</u>

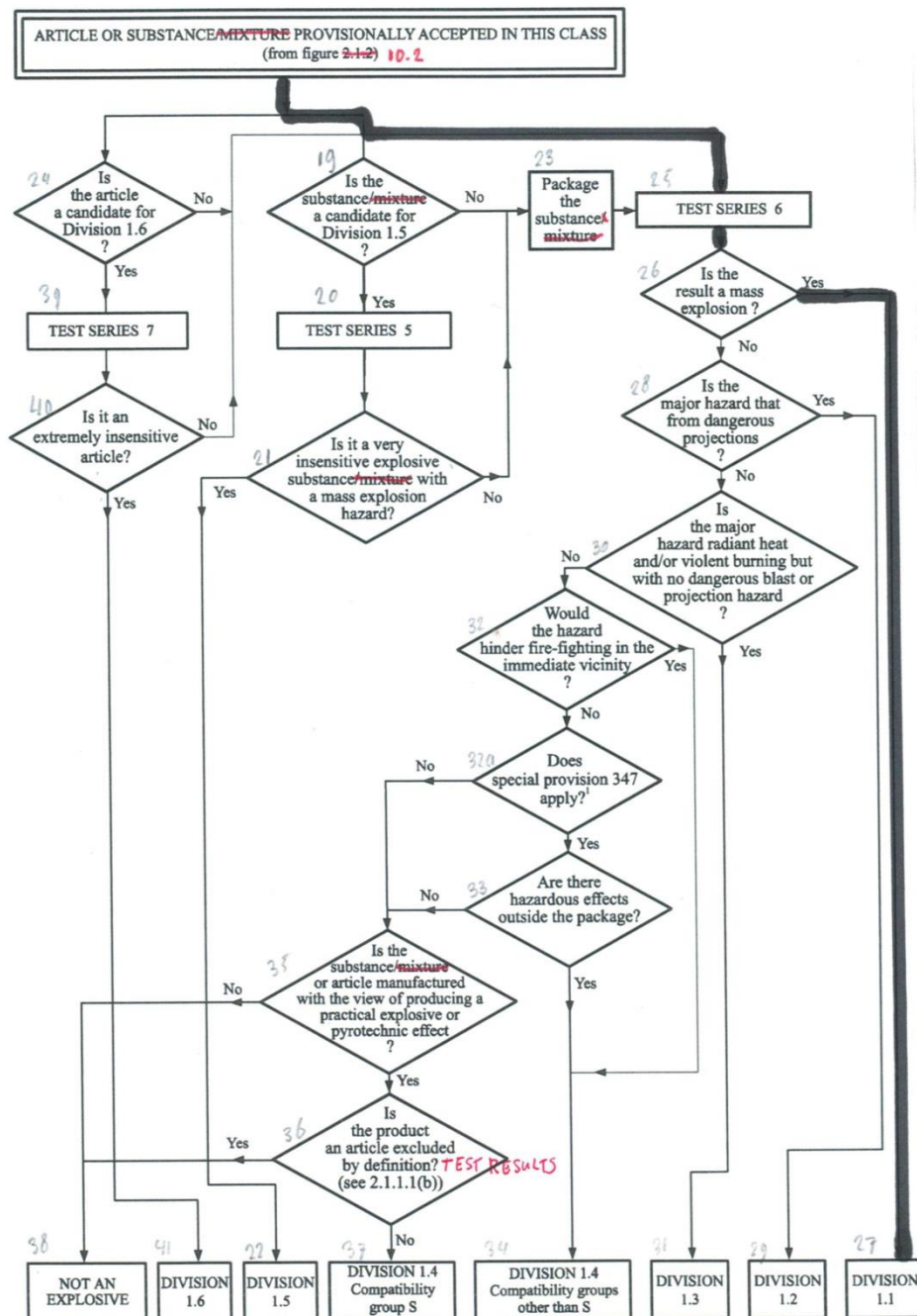
**Figure 10.7: PROCEDURE FOR PROVISIONAL ACCEPTANCE OF HEXANTROSTILBENE MUSK XYLENE IN THE CLASS 1-OF EXPLOSIVES**



**Figure 10.8: RESULTS FROM APPLICATION OF THE CLASS 1 CLASS OF EXPLOSIVES ASSIGNMENT PROCEDURE**

<b>1. Box 19:</b>	Is the substance a candidate for Division 1.5?
1.1 Answer:	No
1.2 Result:	Package the substance (box 23)
1.3 Exit:	Go to box 25
<b>2. Box 25:</b>	Test Series 6
2.1 Effect of initiation in the package:	Test 6(a) with detonator
2.2 Sample conditions:	Ambient temperature, 50 kg fibreboard drum
2.3 Observations:	<del>Detonation, crater</del> Only localised decomposition around detonator
2.4 Result:	<del>Mass explosion</del> No significant reaction
2.5 Effect of ignition <del>in the package</del> between packages:	Test 6( <del>a</del> ) <u>with detonator</u> <del>with igniter</del>
2.6 Sample conditions:	Ambient temperature, <del>50 kg</del> 3 fibreboard drums
2.7 Observations:	<del>Detonation, crater</del> Only localised decomposition around igniter
2.8 Result:	<del>Mass explosion</del> No significant reaction
<del>2.9 Effect of propagation between packages:</del>	Type 6(b) test not required as no effect outside package in 6(a) test
<del>2.10 Effect of fire engulfment:</del>	Type <del>Test 6(bc)</del> test not required as no effect outside package in 6(a) test
<del>2.11 Sample conditions:</del>	<del>3 × 50 kg fibreboard drums mounted on steel frame above wooden crib fire</del>
<del>2.12 Observations:</del>	<del>Only slow burning with black smoke occurred</del>
<del>2.13 Result:</del>	<del>No effects which would hinder fire fighting</del>
<del>2.14 Exit:</del>	<del>Go to box 26</del>
<b>3. Box 26:</b>	Is the result a mass explosion?
3.1 Answer from Test Series 6	<del>No</del> Yes
3.2 Exit	Go to box <del>28</del> 27
<del>4. Box 28:</del>	Is the major hazard that from dangerous projections?
<del>4.1 Answer from Test Series 6:</del>	<del>No</del>
<del>4.2 Exit:</del>	<del>Go to box 30</del>
<del>5. Box 30:</del>	Is the major hazard radiant heat and/or violent burning but with no dangerous blast or projection hazard?
<del>5.1 Answer from Test Series 6:</del>	<del>No</del>
<del>5.2 Exit:</del>	<del>Go to box 32</del>
<del>6. Box 32:</del>	Is there nevertheless a small hazard in the event of ignition or initiation?
<del>6.1 Answer from Test Series 6:</del>	<del>No</del>
<del>6.2 Exit:</del>	<del>Go to box 32a</del>
<del>7. Box 32a:</del>	Does special provision 347 apply?
<del>7.1 Answer:</del>	<del>No</del>
<del>7.2 Exit:</del>	<del>Go to box 32a</del>
<del>8. Box 35:</del>	Is the substance or article manufactured with the view to producing a practical explosive or pyrotechnic effect?
<del>8.1 Answer:</del>	<del>No</del>
<del>8.2 Exit:</del>	<del>Go to box 38</del>
<b>94. Conclusion</b>	<u>Assign to Division 1.1</u> <del>NOT CLASS 1</del>
94.1 Exit:	<del>Consider for another class/division</del>

**Figure 10.9: PROCEDURE FOR CLASSIFICATION OF HEXANITROSTILBENE IN THE CLASS OF EXPLOSIVES EXEMPTION OF MUSK XYLENE FROM CLASS 1**  
**PROCEDURE FOR CLASSIFICATION OF HEXANITROSTILBENE IN THE CLASS OF EXPLOSIVES**





**Figure 10.10: EXAMPLE OF A PROFORMA FOR A TEST REPORT FOR ARTICLES**

Test method		Date of report		Data reference	
Product name		Lot number		Date of manufacture	

CONSTRUCTION AND CONTENTS (attach drawings)

PACKAGING (if any)

PRETREATMENT OR CONDITIONING (if any)

TEST CONFIGURATION (including any variations or deviations from procedures described in the Manual)

TEST CONDITIONS

Ambient temperature:

°C

Relative humidity:

%

OBSERVATIONS

TEST RESULT

CONCLUSION



**SECTION 11****TEST SERIES 1****11.1 Introduction**

11.1.1 The question "Is it an explosive substance?" (box 4 of Figure 10.2) is answered on the basis of the results of three types of test to assess possible explosive effects. The question in box 4 is answered "yes" if a "+" is obtained in any of the three types of test.

**11.2 Test methods**

Test Series 1 is comprised of three types of test:

- Type 1 (a): for determining propagation of detonation;
- Type 1 (b): for determining the effect of heating under confinement; and
- Type 1 (c): for determining the effect of ignition under confinement

The test methods currently used are listed in Table 11.1.

**Table 11.1: TEST METHODS FOR TEST SERIES 1**

Test code	Name of Test	Section
1 (a)	UN gap test <sup>a</sup>	11.4.1
1 (b)	Koenen test <sup>a</sup>	11.5.1
1 (c) (i)	Time/pressure test <sup>a</sup>	11.6.1
1 (c) (ii)	Internal ignition test	11.6.2

<sup>a</sup> *Recommended test*

**11.3 Test conditions**

11.3.1 As the apparent density of the substance has an important effect on the results from the type 1 (a) test, it should always be recorded. The apparent density of solids should be determined from measurement of the tube volume and sample mass.

11.3.2 If a mixture can separate out ~~during transport~~, the test should be performed with the initiator in contact with the potentially most explosive part, if known.

11.3.3 The tests ~~should be~~ performed at ambient temperature unless the substance is ~~to be transported under likely to encounter~~ conditions where it may change its physical state or density.

11.3.4 If a liquid is being considered for ~~transport packing~~ in tank-containers, or intermediate bulk containers with a capacity exceeding 450 litres, a cavitated version of the type 1 (a) test should be performed (see special provision 26 of Chapter 3.3 of the Model Regulations).

11.3.5 For organic substances and mixtures of organic substances with a decomposition energy of 800 J/g or more, test 1 (a) need not be performed if the outcome of the ballistic mortar Mk.III d test (F.1), or the ballistic mortar test (F.2) or the BAM Trauzl test (F.3) with initiation by a standard No. 8 detonator (see Appendix 1) is "No". In this case, the result of test 1 (a) is deemed to be "-". If the outcome of the F.1 or F.2 or F.3 test is "Low" or "Not low", the result of test 1 (a) shall be deemed "+". In this case, a "-" can only be obtained by performing test 1 (a).

## 11.4 Series 1 type (a) test prescription

### 11.4.1 Test 1 (a): UN gap test

#### 11.4.1.1 Introduction

This test is used to measure the ability of a substance, under confinement in a steel tube, to propagate a detonation by subjecting it to the detonation from a booster charge.

#### 11.4.1.2 Apparatus and materials

##### 11.4.1.2.1 Solids

The apparatus for solids is shown in Figure 11.4.1.1. The test sample is contained in a ~~cold-drawn~~, seamless, carbon steel tube with an external diameter of  $48 \pm 2$  mm, a wall thickness of 4 mm and a length of  $400 \pm 5$  mm. If the test substance may react with the steel, the inside of the tube may be coated with fluorocarbon resin. The bottom of the tube is closed with a plastics sheet pulled tightly (so that it plastically deforms) over the bottom of the tube and held tightly in place. The plastics sheet shall be compatible with the substance under test. The booster charge consists of 160 g RDX/wax (95/5) or PETN/TNT that has a minimum of 50% PETN in the mixture,  $50 \pm 1$  mm in diameter with a density of  $1\,600 \pm 50$  kg/m<sup>3</sup>. The charges may be pressed in one or more pieces, as long as the total charge is within the specifications, and the PETN/TNT charge is cast. A mild steel witness plate,  $150 \pm 10$  mm square and 3 mm thick, may be mounted at the upper end of the steel tube and separated from it by spacers  $1.6 \pm 0.2$  mm thick.

##### 11.4.1.2.2 Liquids

The apparatus for liquids is the same as that for solids. When a cavitated version of the test is performed (see 11.3.4), one of the methods of cavitation given in Appendix 3 may be used.

#### 11.4.1.3 Procedure

11.4.1.3.1 The sample is loaded to the top of the steel tube. Solid samples are loaded to the density attained by tapping the tube until further settling becomes imperceptible. The sample mass is determined and, if solid, the apparent density calculated using the measured internal volume of the tube.

11.4.1.3.2 The tube is placed in a vertical position and the booster charge is placed in direct contact with the sheet which seals the bottom of the tube. The detonator is fixed in place against the booster charge and initiated. Two tests should be performed unless detonation of the substance is observed.

#### 11.4.1.4 Test criteria and method of assessing results

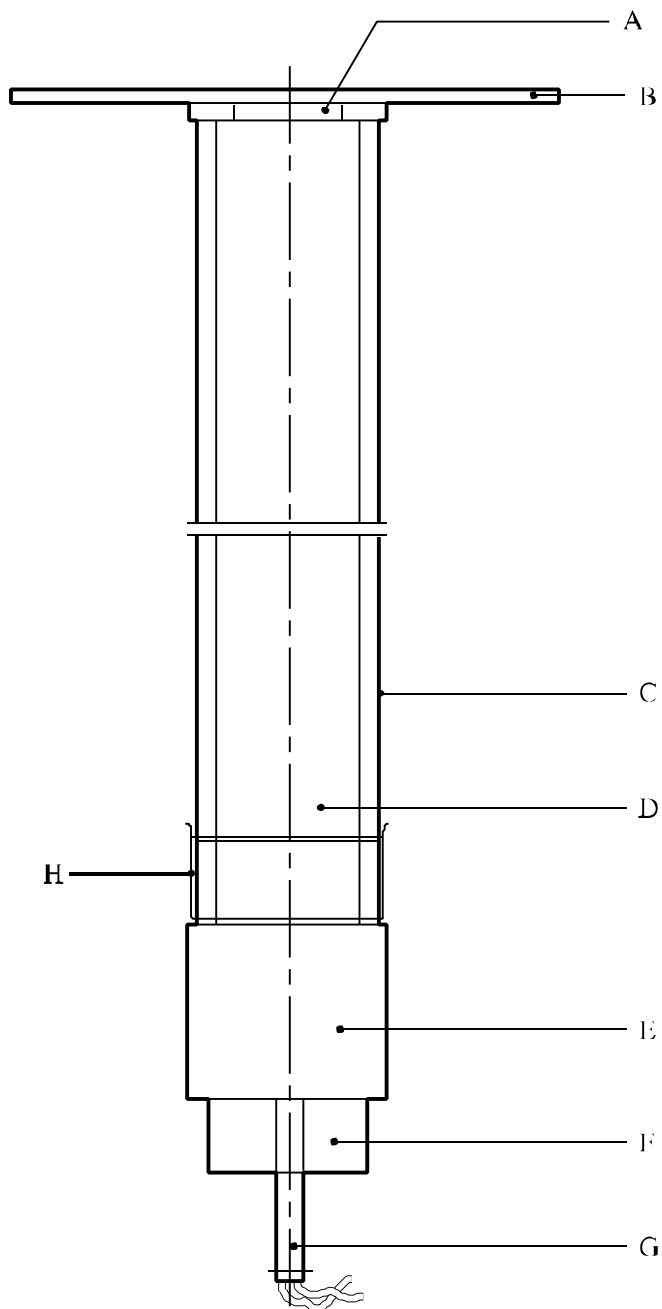
The test results are assessed on the basis of the type of fragmentation of the tube or on whether a hole is punched through the witness plate. The test giving the most severe assessment should be used for classification. The test result is considered "+" and the substance to propagate detonation if:

- The tube is fragmented completely; or
- A hole is punched through the witness plate.

Any other result is considered "-" and the substance is considered not to be able to propagate a detonation.

11.4.1.5 *Examples of results*

<b>Substances</b>	<b>Apparent density (kg/m<sup>3</sup>)</b>	<b>Fragmentation length (cm)</b>	<b>Witness plate</b>	<b>Result</b>
Ammonium nitrate, prills	800	40	Domed	+
Ammonium nitrate, 200 µm	540	40	Holed	+
Ammonium nitrate/fuel oil, 94/6	880	40	Holed	+
Ammonium perchlorate, 200 µm	1 190	40	Holed	+
Nitromethane	1 130	40	Holed	+
Nitromethane/methanol, 55/45	970	20	Domed	-
PETN/lactose, 20/80	880	40	Holed	+
PETN/lactose, 10/90	830	17	No damage	-
TNT, cast	1 510	40	Holed	+
TNT, flaked	710	40	Holed	+
Water	1 000	<40	Domed	-



- 
- |     |                                    |     |                               |
|-----|------------------------------------|-----|-------------------------------|
| (A) | Spacers                            | (B) | Witness plate                 |
| (C) | Steel tube                         | (D) | Substance under investigation |
| (E) | RDX/wax or PETN/TNT booster charge | (F) | Detonator holder              |
| (G) | Detonator                          | (H) | Plastics membrane             |
- 

**Figure 11.4.1.1: UN GAP TEST**

## 11.5 Series 1 type (b) test prescription

### 11.5.1 Test 1 (b): Koenen test

#### 11.5.1.1 Introduction

This test is used to determine the sensitiveness of solid and liquid substances to the effect of intense heat under high confinement.

#### 11.5.1.2 Apparatus and materials

11.5.1.2.1 The apparatus consists of a non-reusable steel tube, with its re-usable closing device, installed in a heating and protective device. The tube is deep drawn from sheet steel conforming to specification DC04 (EN 10027-1), or equivalent A620 (AISI/SAE/ASTM), or equivalent SPCEN (JIS g 3141). The dimensions are given in Figure 11.5.1.1. The open end of the tube is flanged. The closing plate with an orifice, through which the gases from the decomposition of the test substance escape, is made from heat-resisting chrome steel and is available with the following diameter holes: 1.0 - 1.5 - 2.0 - 2.5 - 3.0 - 5.0 - 8.0 - 12.0 - 20.0 mm. The dimensions of the threaded collar and the nut (closing device) are given in Figure 11.5.1.1.

For quality control of the steel tubes, 1% of the tubes from each production lot shall be subjected to quality control and the following data shall be verified:

- (a) The mass of the tubes shall be  $26.5 \pm 1.5$  g, tubes to be used in one test sequence shall not differ in mass by more than 1 g;
- (b) The length of the tubes shall be  $75 \pm 0.5$  mm;
- (c) The wall thickness of the tubes measured 20 mm from the bottom of the tube shall be  $0.5 \pm 0.05$  mm; and
- (d) The bursting pressure as determined by quasi-static load through an incompressible fluid shall be  $30 \pm 3$  MPa.

11.5.1.2.2 Heating is provided by propane, from an industrial cylinder fitted with a pressure regulator, via a flow meter and distributed by a manifold to the four burners. Other fuel gases may be used provided the specified heating rate is obtained. The gas pressure is regulated to give a heating rate of  $3.3 \pm 0.3$  K/s when measured by the calibration procedure. Calibration involves heating a tube (fitted with a 1.5 mm orifice plate) filled with 27 cm<sup>3</sup> of dibutyl phthalate. The time taken for the temperature of the liquid (measured with a 1 mm diameter thermocouple centrally placed 43 mm below the rim of the tube) to rise from 135 °C to 285 °C is recorded and the heating rate calculated.

11.5.1.2.3 Because the tube is likely to be destroyed in the test, heating is undertaken in a protective welded box, the construction and dimensions of which are given in Figure 11.5.1.2. The tube is suspended between two rods placed through holes drilled in opposite walls of the box. The arrangement of the burners is given in Figure 11.5.1.2. The burners are lit simultaneously by a pilot flame or an electrical ignition device. **The test apparatus is placed in a protective area.** Measures should be taken to ensure that the burner flames are not affected by any draughts. Provision should be made for extracting any gases or smoke resulting from the test.

11.5.1.3 Procedure

11.5.1.3.1 Normally substances are tested as received, although in certain cases it may be necessary to test the substance after crushing it. For solids, the mass of material to be used in each test is determined using a two-stage dry run procedure. A tared tube is filled with 9 cm<sup>3</sup> of substance and the substance tamped<sup>1</sup> with 80 N force applied to the total cross-section of the tube. If the material is compressible then more is added and tamped until the tube is filled to 55 mm from the top. The total mass used to fill the tube to the 55 mm level is determined and two further increments, each tamped with 80 N force, are added. Material is then either added, with tamping, or taken out as required to leave the tube filled to a level 15 mm from the top.

A second dry run is performed, starting with a tamped increment a third of the total mass found in the first dry run. Two more of these increments are added with 80 N tamping and the level of the substance in the tube adjusted to 15 mm from the top by addition or subtraction of material as required. The amount of solid determined in the second dry run is used for each trial filling being performed in three equal increments, each compressed to 9 cm<sup>3</sup>. (This may be facilitated by the use of spacing rings.) Liquids and gels are loaded into the tube to a height of 60 mm taking particular care with gels to prevent the formation of voids. The threaded collar is slipped onto the tube from below, the appropriate orifice plate is inserted and the nut tightened by hand after applying some molybdenum disulphide based lubricant. It is essential to check that none of the substance is trapped between the flange and the plate, or in the threads.

11.5.1.3.2 With orifice plates from 1.0 mm to 8.0 mm diameter, nuts with an orifice of 10.0 mm diameter should be used; if the diameter of the orifice is above 8.0 mm, that of the nut should be 20.0 mm. Each tube is used for one trial only. The orifice plates, threaded collars and nuts may be used again provided they are undamaged.

11.5.1.3.3 The tube is placed in a rigidly mounted vice and the nut tightened with a spanner. The tube is then suspended between the two rods in the protective box. The test area is vacated, the gas supply turned on and the burners lit. The time to reaction and duration of reaction can provide additional information useful in interpreting the results. If rupture of the tube does not occur, heating is to be continued for at least five minutes before the trial is finished. After each trial the fragments of the tube, if any, should be collected and weighed.

11.5.1.3.4 The following effects are differentiated:

- "O": Tube unchanged;
- "A": Bottom of tube bulged out;
- "B": Bottom and wall of the tube bulged out;
- "C": Bottom of tube split;
- "D": Wall of tube split;
- "E": Tube split into two<sup>2</sup> fragments;
- "F": Tube fragmented into three<sup>2</sup> or more mainly large pieces which in some cases may be connected with each other by a narrow strip;
- "G": Tube fragmented into many mainly small pieces, closing device undamaged; and
- "H": Tube fragmented into many very small pieces, closing device bulged out or fragmented.

Examples for the effect types "D", "E" and "F" are shown in Figure 11.5.1.3. If a trial results in any of the effects "O" to "E", the result is regarded as "no explosion". If a trial gives the effect "F", "G" or "H", the result is evaluated as "explosion".

11.5.1.3.5 The series of trials is started with a single trial using an orifice plate of 20.0 mm. If, in this trial, the result "explosion" is observed, the series is continued with trials using tubes without orifice plates and nuts but with threaded collars (orifice 24.0 mm). If at 20.0 mm "no explosion" occurs, the series is continued with single trials using plates with the following orifices 12.0 - 8.0 - 5.0 - 3.0 - 2.0 - 1.5 and finally 1.0 mm until, at one of these diameters, the result "explosion" is obtained. Subsequently, trials are carried out at increasing diameters, according to the sequence given in 11.5.1.2.1, until only negative results in three tests at the same level are obtained. The limiting diameter of a substance is the largest diameter of the orifice at which the result "explosion" is obtained. If no "explosion" is obtained with a diameter of 1.0 mm, the limiting diameter is recorded as being less than 1.0 mm.

---

<sup>1</sup> *For reasons of safety, e.g. the substance is friction sensitive, the substance need not be tamped. In cases where the physical form of the sample can be changed by compression or compression of the sample is not related to the ~~transport~~ packaging conditions, e.g. for fibrous materials, more representative filling procedures may be used.*

<sup>2</sup> *The upper part of the tube remaining in the closing device is counted as one fragment.*

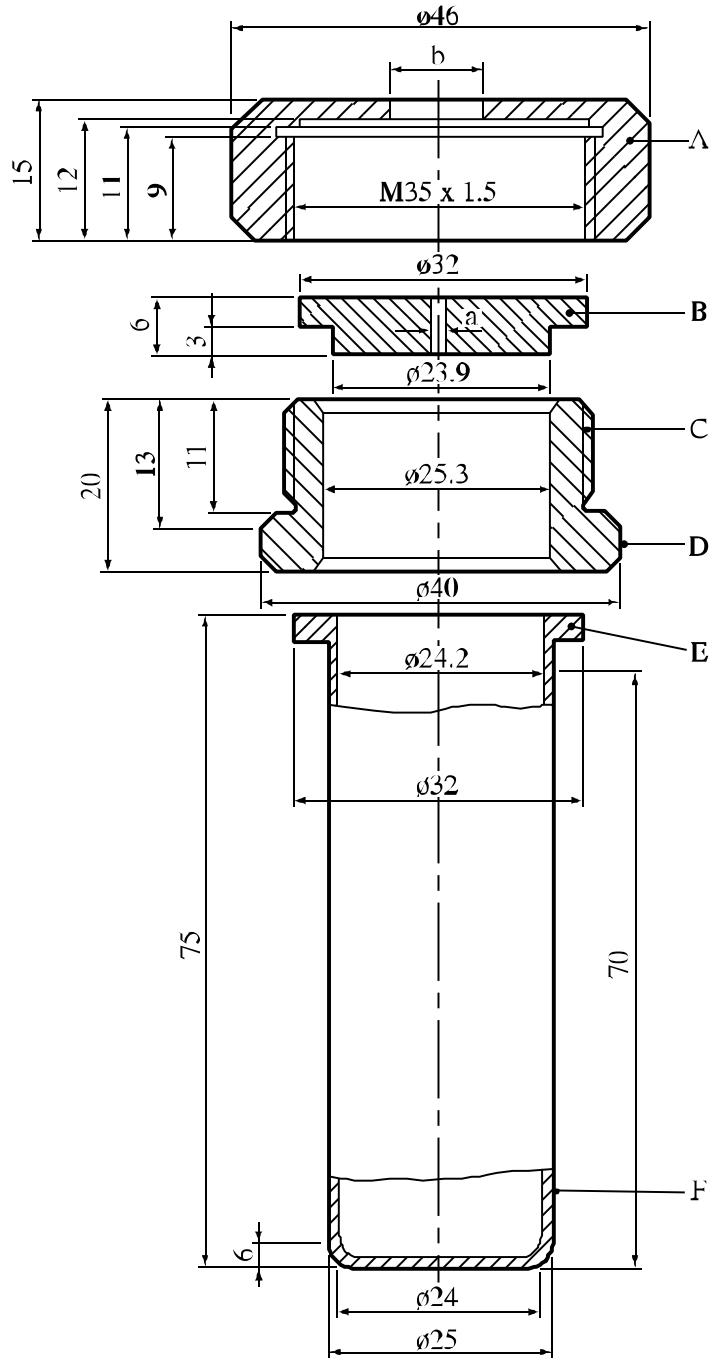


11.5.1.4 *Test criteria and method of assessing results*

The result is considered "+" and the substance to show some effect on heating under confinement if the limiting diameter is 1.0 mm or more. The result is considered "-" and the substance to show no effect on heating under confinement if the limiting diameter is less than 1.0 mm.

11.5.1.5 *Examples of results*

<b>Substances</b>	<b>Limiting diameter (mm)</b>	<b>Result</b>
Ammonium nitrate (crystalline)	1.0	+
Ammonium nitrate (high density prills)	1.0	+
Ammonium nitrate (low density prills)	1.0	+
Ammonium perchlorate	3.0	+
1,3-Dinitrobenzene (crystalline)	< 1.0	-
2,4-Dinitrotoluene (crystalline)	<1.0	-
Guanidine nitrate (crystalline)	1.5	+
Nitroguanidine (crystalline)	1.0	+
Nitromethane	<1.0	-
Urea nitrate (crystalline)	<1.0	-



- |     |   |     |   |
|-----|---|-----|---|
| (A) | Nut ( $b = 10.0$ or $20.0$ mm) with flats for size 41 spanner | (B) | Orifice plate ( $a = 1.0 \rightarrow 20.0$ mm diameter) |
| (C) | Threaded collar   | (D) | Flats for size 36 spanner                               |
| (E) | Flange  | (F) | Tube  |

**Figure 11.5.1.1: TEST TUBE ASSEMBLY**

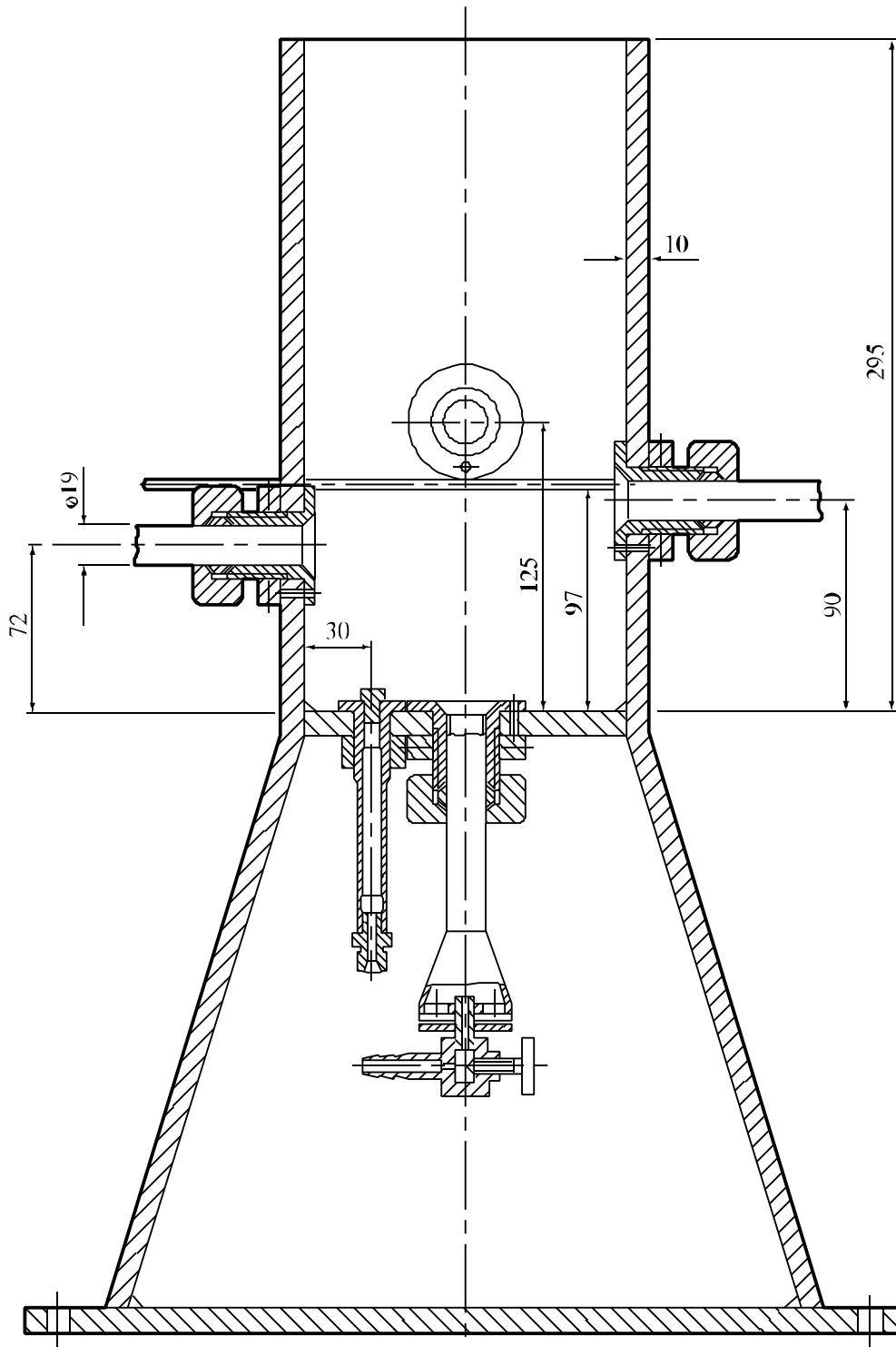


Figure 11.5.1.2: HEATING AND PROTECTIVE DEVICE

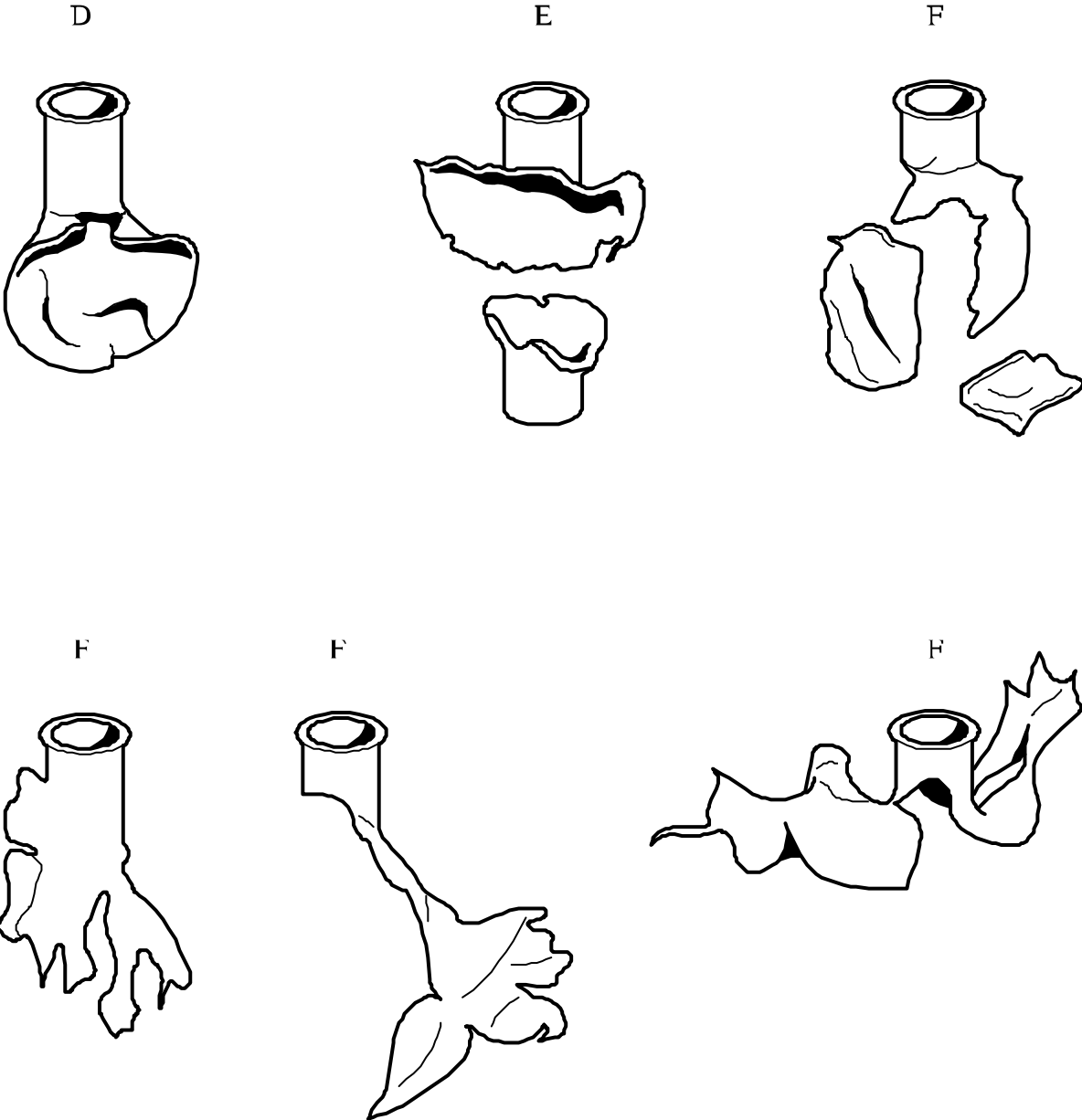


Figure 11.5.1.3: EXAMPLES OF EFFECT TYPES D, E AND F

**11.6 Series 1 type (c) test prescriptions****11.6.1 Test 1 (c) (i): Time/pressure test**11.6.1.1 *Introduction*

This test is used to determine the effects of igniting the substance<sup>3</sup> under confinement in order to determine if ignition leads to a deflagration with explosive violence at pressures which can be attained with substances in normal commercial packages.

11.6.1.2 *Apparatus and materials*

11.6.1.2.1 The time/pressure apparatus (Figure 11.6.1.1) consists of a cylindrical steel pressure vessel 89 mm in length and 60 mm in external diameter. Two flats are machined on opposite sides (reducing the cross-section of the vessel to 50 mm) to facilitate holding whilst fitting the firing plug and vent plug. The vessel, which has a bore of 20 mm diameter, is internally rebated at either end to a depth of 19 mm and threaded to accept 1" British Standard Pipe (BSP). A pressure take-off, in the form of a side-arm, is screwed into the curved face of the pressure vessel 35 mm from one end and at 90° to the machined flats. The socket for this is bored to a depth of 12 mm and threaded to accept the 1/2" BSP thread on the end of the side-arm. A washer is fitted to ensure a gastight seal. The side-arm extends 55 mm beyond the pressure vessel body and has a bore of 6 mm. The end of the side-arm is rebated and threaded to accept a diaphragm type pressure transducer. Any pressure-measuring device may be used provided that it is not affected by the hot gases or decomposition products and is capable of responding to rates of pressure rise of 690-2 070 kPa in not more than 5 ms.

11.6.1.2.2 The end of the pressure vessel furthest from the side-arm is closed with a firing plug which is fitted with two electrodes, one insulated from, and the other earthed to, the plug body. The other end of the pressure vessel is closed by an aluminium bursting disc 0.2 mm thick (bursting pressure approximately 2 200 kPa) held in place with a retaining plug which has a 20 mm bore. A soft lead washer or a washer of a suitable deformable material (for example, polyoxymethylene) is used with both plugs to ensure a good seal. A support stand (Figure 11.6.1.2) holds the assembly in the correct attitude during use. This comprises a mild steel base plate measuring 235 mm × 184 mm × 6 mm and a 185 mm length of square hollow section (S.H.S.) 70 × 70 × 4 mm.

11.6.1.2.3 A section is cut from each of two opposite sides at one end of the length of S.H.S. so that a structure having two flat sided legs surmounted by an 86 mm length of intact box section results. The ends of these flat sides are cut to an angle of 60° to the horizontal and welded to the base plate.

11.6.1.2.4 A slot measuring 22 mm wide × 46 mm deep is machined in one side of the upper end of the base section such that when the pressure vessel assembly is lowered, firing plug end first, into the box section support, the side-arm is accommodated in this slot. A packing piece of steel 30 mm wide and 6 mm thick is welded to the lower internal face of the box section to act as a spacer. Two 7 mm thumb screws, tapped into the opposite face, serve to hold the pressure vessel firmly in place. Two 12 mm wide strips of 6 mm thick steel, welded to the side pieces abutting the base of the box section, support the pressure vessel from beneath.

11.6.1.2.5 The ignition system consists of an electric fusehead of the type commonly used in low tension detonators, together with a 13 mm square piece of primed cambric. Fuseheads with equivalent properties may be used. Primed cambric consists of a linen fabric coated on both sides with a potassium nitrate/silicon/sulphurless gunpowder pyrotechnic composition<sup>4</sup>.

11.6.1.2.6 The procedure for the preparation of the ignition assembly for solids starts with separation of the brass foil contacts of an electric fusehead from its insulator, (see Figure 11.6.1.3). The exposed portion of insulation is then cut off. The fusehead is then fixed onto the terminals of the firing plug by means of the brass contacts such that the tip of the fusehead is 13 mm above the surface of the firing plug. A 13 mm square

<sup>3</sup> When testing thermally stable energetic liquids, such as nitromethane (UN 1261), variable results may be obtained because the substance may give two pressure peaks.

<sup>4</sup> Obtainable from the national contact for test details in United Kingdom (see Appendix 4).

piece of primed cambric is pierced through the centre and positioned over the attached fusehead around which it is then folded and secured with fine cotton thread.

11.6.1.2.7 For liquids samples, leads are fixed onto the contact foils of the fusehead. The leads are then threaded through an 8 mm length of 5 mm outer diameter and 1 mm inner diameter silicone rubber tubing and the tubing is pushed up over the fusehead contact foils as shown in Figure 11.6.1.4. The primed cambric is then wrapped around the fusehead and a single piece of thin PVC sheathing, or equivalent, is used to cover the primed cambric and the silicone rubber tubing. The sheathing is sealed in position by twisting a length of thin wire tightly round the sheathing and rubber tubing. The leads are then fixed onto the terminals of the firing plug such that the tip of the fusehead is 13 mm above the surface of the firing plug.

#### 11.6.1.3 *Procedure*

11.6.1.3.1 The apparatus, assembled complete with pressure transducer but without the aluminium bursting disc in position, is supported firing plug end down. 5.0 g<sup>5</sup> of the substance is introduced into the apparatus so as to be in contact with the ignition system. Normally no tamping is carried out when filling the apparatus unless it is necessary to use light tamping in order to get the 5.0 g charge into the vessel. If, even with light tamping, it is impossible to get all the 5.0 g of sample in, then the charge is fired after filling the vessel to capacity. Note should be taken of the charge weight used. The lead washer and aluminium bursting disc are placed in position and the retaining plug is screwed in tightly. The charged vessel is transferred to the firing support stand, bursting disc uppermost, which should be contained in a suitable, armoured fume cupboard or firing cell. An exploder dynamo is connected to the external terminals of the firing plug and the charge is fired. The signal produced by the pressure transducer is recorded on a suitable system which allows both evaluation and a permanent record of the time/pressure profile to be achieved (e.g. transient recorder coupled to a chart-recorder).

11.6.1.3.2 The test is carried out three times. The time taken for the pressure to rise from 690 kPa to 2 070 kPa above atmospheric is noted. The shortest time interval should be used for classification.

#### 11.6.1.4 *Test criteria and method of assessing results*

The test results are interpreted in terms of whether a gauge pressure of 2 070 kPa is reached and, if so, the time taken for the pressure to rise from 690 kPa to 2 070 kPa gauge.

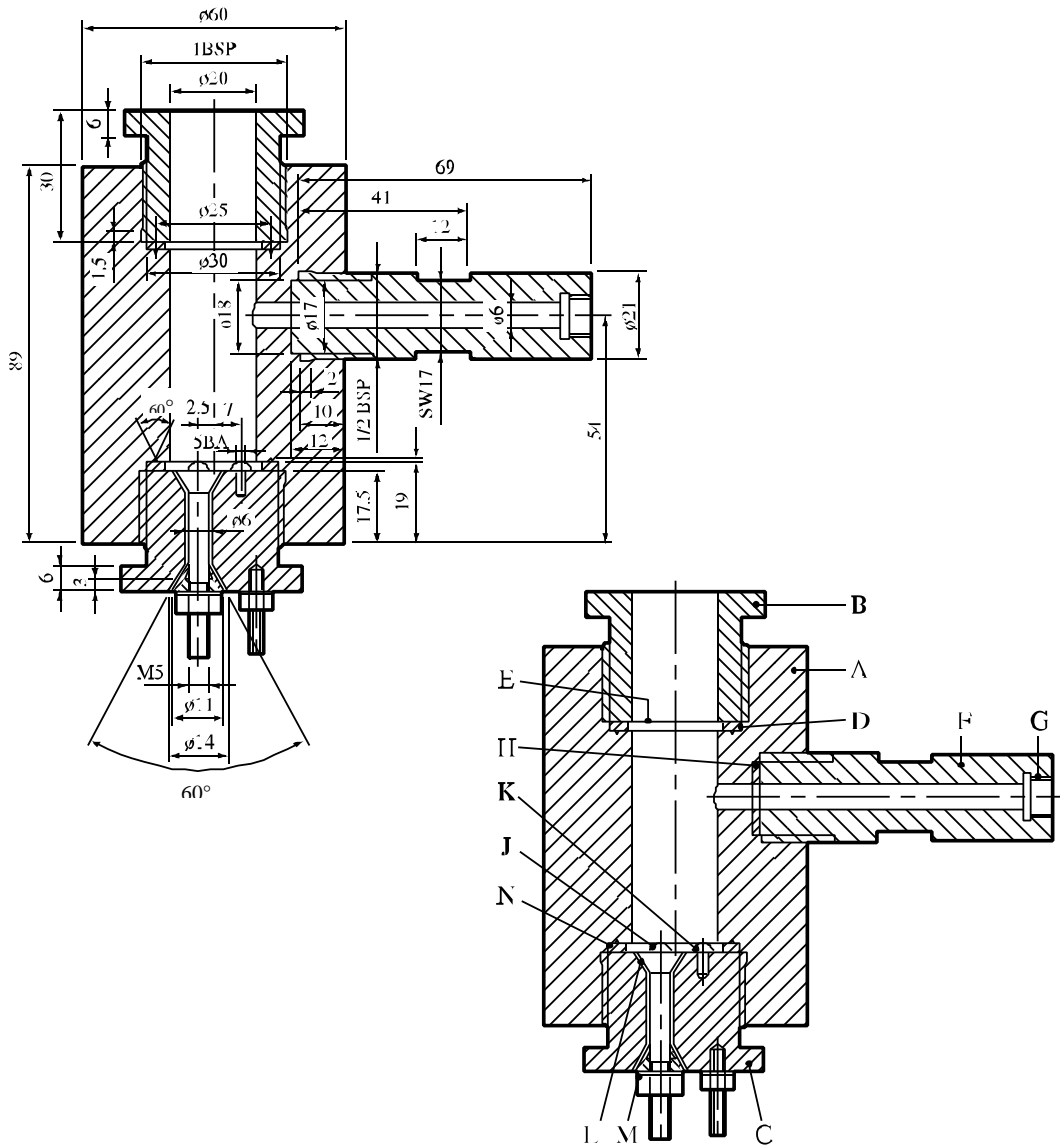
The result is considered "+" and the substance to show the ability to deflagrate if the maximum pressure reached is greater than or equal to 2 070 kPa. The result is considered "-" and the substance to show no likelihood of deflagration if the maximum pressure reached in any one test is less than 2 070 kPa gauge. Failure to ignite does not necessarily indicate that the substance has no explosive properties.

---

<sup>5</sup> *If preliminary safety-in-handling tests (e.g. heating in a flame) or unconfined burning tests (e.g. a Series 3 type (d) test) indicate that a rapid reaction is likely to occur, then the sample size should be reduced to 0.5 g until the severity of the confined reaction is known. If it is necessary to use a 0.5 g sample, the sample size should be gradually increased until either a "+" result is obtained or the test is performed with a 5.0 g sample.*

11.6.1.5 *Examples of results*

<b>Substances</b>	<b>Maximum pressure (kPa)</b>	<b>Time for a pressure rise from 690 to 2 070 kPa (ms)</b>	<b>Result</b>
Ammonium nitrate (high density prills)	< 2 070	-	-
Ammonium nitrate (low density prills)	< 2 070	-	-
Ammonium perchlorate (2 µm)	> 2 070	5	+
Ammonium perchlorate (30 µm)	> 2 070	15	+
Barium azide	> 2 070	<5	+
Guanidine nitrate	> 2 070	606	+
Isobutyl nitrite	> 2 070	80	+
Isopropyl nitrate	> 2 070	10	+
Nitroguanidine	> 2 070	400	+
Picramic acid	> 2 070	500	+
Sodium picramate	> 2 070	15	+
Urea nitrate	> 2 070	400	+



- |     |                            |     |                              |
|-----|----------------------------|-----|------------------------------|
| (A) | Pressure vessel body       | (B) | Bursting disc retaining plug |
| (C) | Firing plug                | (D) | Soft lead washer             |
| (E) | Bursting disc              | (F) | Side arm                     |
| (G) | Pressure transducer thread | (H) | Copper washer                |
| (J) | Insulated Electrode        | (K) | Earthed electrode            |
| (L) | Insulation                 | (M) | Steel cone                   |
| (N) | Washer distorting groove   |     |                              |

Figure 11.6.1.1: APPARATUS



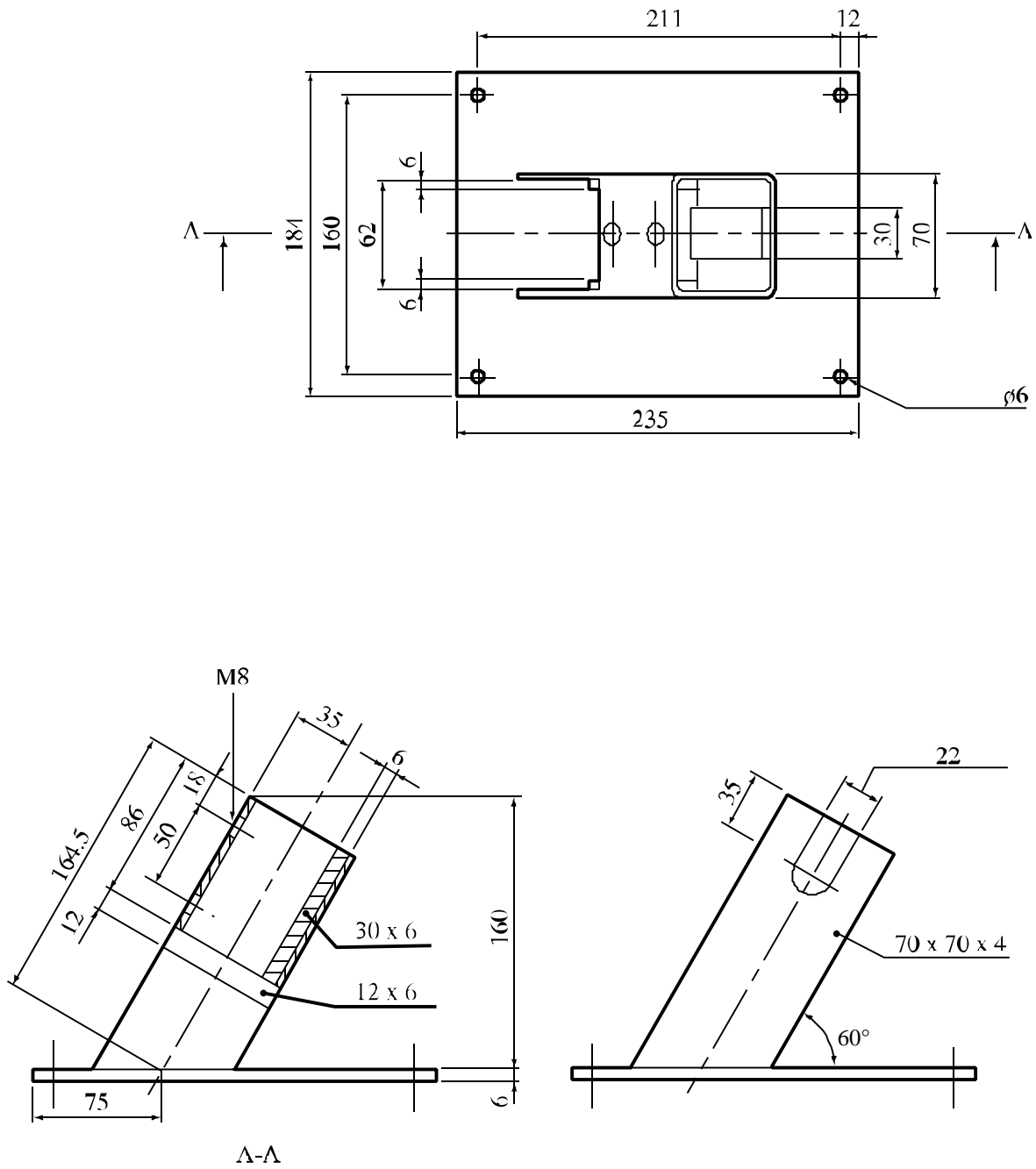
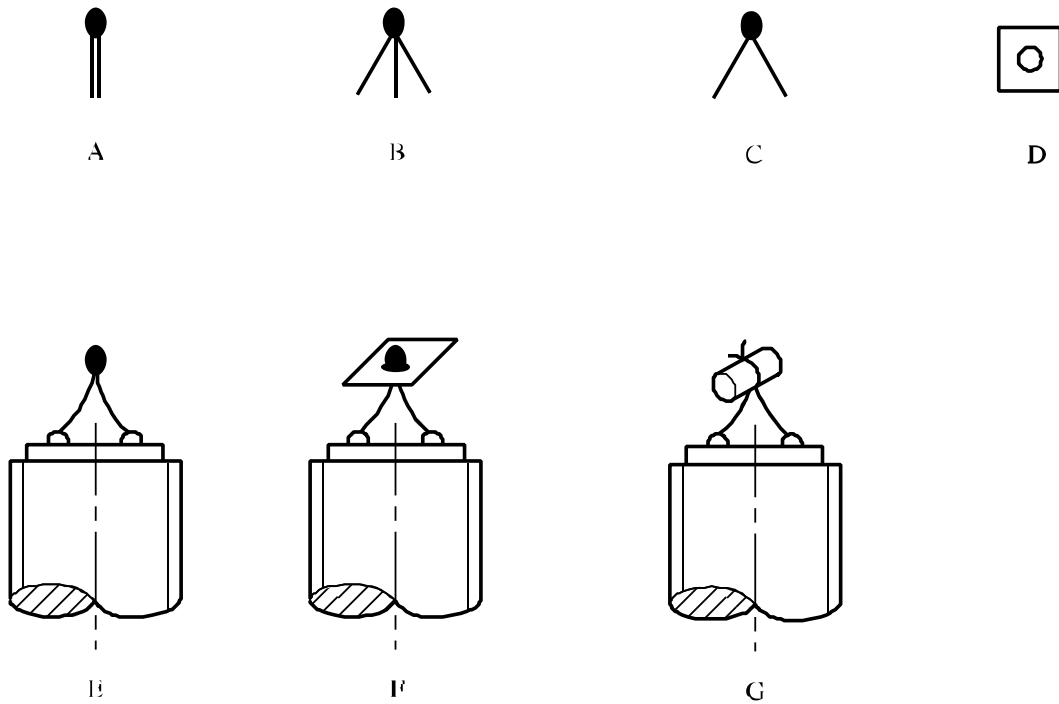
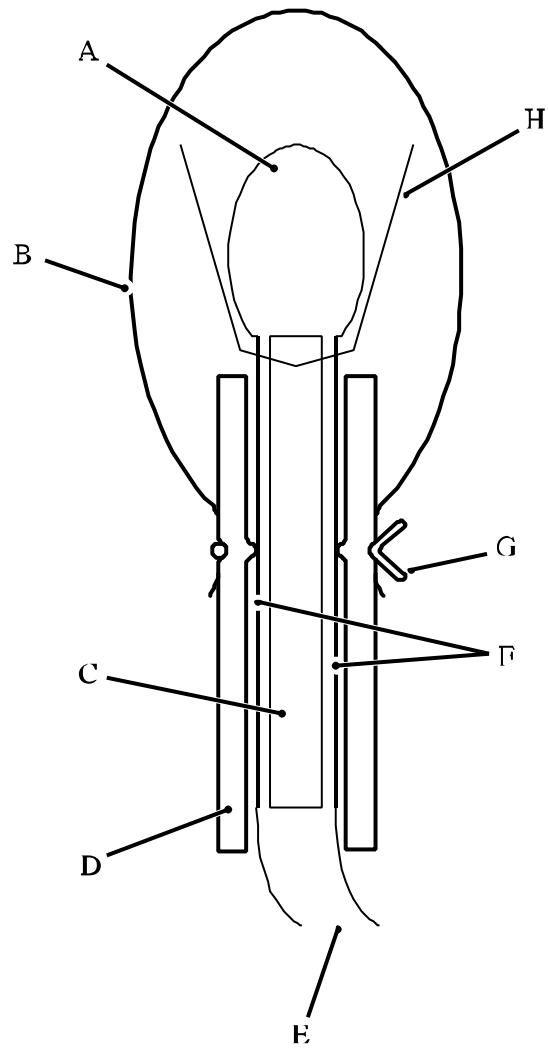


Figure 11.6.1.2: SUPPORT STAND



- 
- (A) Electrically ignited fusehead as manufactured
  - (B) Brass foil contacts parted from card insulator
  - (C) Insulating card cut off
  - (D) Primed cambric SR252 13 mm square with centre hole
  - (E) Fusehead fixed to pins on firing plug
  - (F) Cambric positioned on fusehead
  - (G) Cambric folded around and tied with thread
- 

**Figure 11.6.1.3: IGNITION SYSTEM FOR SOLIDS**



- 
- (A) Fusehead
  - (B) PVC sheath
  - (C) Insulating card
  - (D) Silicone rubber tubing
  - (E) Firing leads
  - (F) Foil contacts
  - (G) Wire to make liquid-tight seal
  - (H) Primed cambric
- 

**Figure 11.6.1.4: IGNITION SYSTEM FOR LIQUIDS**

---

**11.6.2**            *Test 1 (c) (ii): Internal ignition test*

11.6.2.1           *Introduction*

This test is used to determine the tendency of a substance to undergo transition from deflagration to detonation.

11.6.2.2           *Apparatus and materials*

The experimental arrangement is shown in Figure 11.6.2.1. The sample of substance to be tested is contained in a 45.7 cm length of "3 inch schedule 80" carbon (A53 Grade B) steel pipe with inside diameter 74 mm, wall thickness 7.6 mm, capped at both ends with a "3 000 pound" forged steel pipe cap. An igniter consisting of 20 g of black powder (100% passed through No. 20 sieve, 0.84 mm, and 100% retained by No. 50 sieve, 0.297 mm) is located at the centre of the sample vessel. The igniter assembly consists of a cylindrical container 21 mm in diameter and 64 mm long which is made from 0.54 mm thick cellulose acetate which is held together by two layers of nylon filament reinforced cellulose acetate tape. The igniter capsule contains a small loop formed from a 25 mm length of nickel-chromium alloy resistance wire 0.30 mm in diameter having a resistance of 0.35 Ohms. This loop is attached to two insulated tinned copper lead wires 0.7 mm in diameter. The overall wire diameter, including insulation, is 1.3 mm. These lead wires are fed through small holes in the wall of the pipe and are sealed with epoxy resin.

11.6.2.3           *Procedure*

After the sample, at ambient temperature, is loaded into the pipe to a height of 23 cm, the igniter (with its leads inserted through small holes in the pipe wall) is inserted into the centre of the pipe and the leads pulled taut and sealed with epoxy resin. The remainder of the sample is then loaded and the top cap screwed on. For gelatinous samples, the substance is packed as near as possible to its normal shipping density. For granular samples, the substance is loaded to the density obtained by repeated tapping of the pipe against a hard surface. The tube is placed in a vertical position and the igniter is fired by a current of 15 amperes obtained from a 20-volt transformer. Three trials should be performed unless deflagration to detonation transition occurs earlier.

11.6.2.4           *Test criteria and method of assessing results*

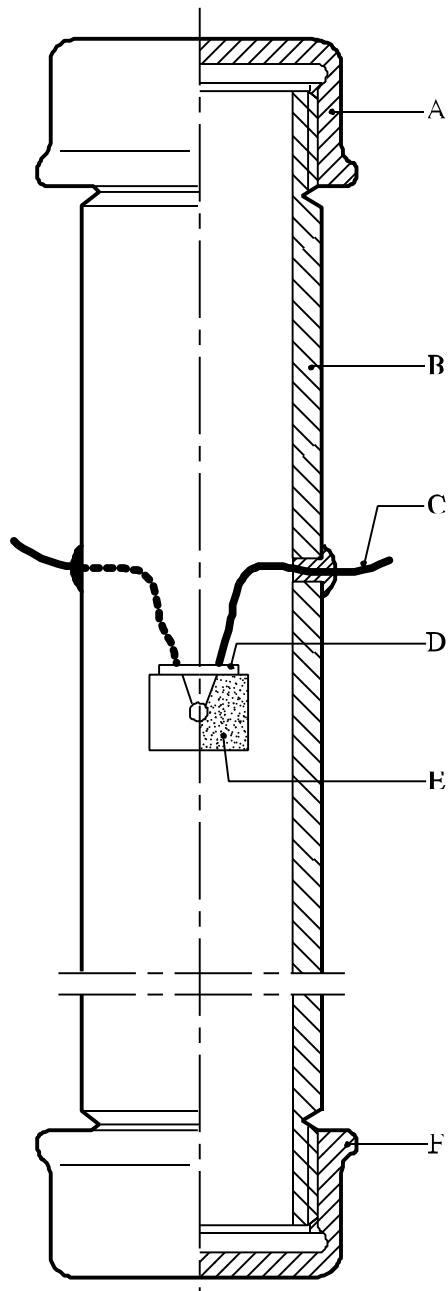
The test result is considered "+" if either the pipe or at least one of the end caps is fragmented into at least two distinct pieces. Results in which the pipe is merely split or laid open, or in which the pipe or caps are distorted to the point at which the caps are blown off, are considered "-".

11.6.2.5           *Examples of results*

---

<b>Substance</b>	<b>Results</b>
Ammonium nitrate/fuel oil, aluminised	+
Ammonium nitrate prills, porous, low density	-
Ammonium perchlorate (45 µm)	+
Nitrocarbonitrate	-
TNT, granular	+
Watergel	+

---



- |     |                  |     |                  |
|-----|------------------|-----|------------------|
| (A) | Forged steel cap | (B) | Steel pipe       |
| (C) | Igniter leads    | (D) | Seal             |
| (E) | Igniter assembly | (F) | Forged steel cap |

Figure 11.6.2.1: INTERNAL IGNITION TEST

## SECTION 12

### TEST SERIES 2

#### 12.1 Introduction

12.1.1 The question "Is the substance too insensitive for inclusion in [the class of explosives Class 1?](#)" (box 6 of Figure 10.2) is answered on the basis of three types of test to assess possible explosive effects. The question in box 6 is answered "no" if a "+" is obtained in any of the three types of test.

#### 12.2 Test methods

Test Series 2 comprises three types of test:

- Type 2 (a): for determining sensitivity to shock;
- Type 2 (b): for determining the effect of heating under confinement; and
- Type 2 (c): for determining the effect of ignition under confinement

The test methods currently used are listed in table 12.1.

**Table 12.1: TEST METHODS FOR TEST SERIES 2**

Test code	Name of Test	Section
2 (a)	UN gap test <sup>a</sup>	12.4.1
2 (b)	Koenen test <sup>a</sup>	12.5.1
2 (c) (i)	Time/pressure test <sup>a</sup>	12.6.1
2 (c) (ii)	Internal ignition test	12.6.2

<sup>a</sup> *Recommended test.*

#### 12.3 Test conditions

12.3.1 As the apparent density of the substance has an important effect on the results from the type 2 (a) test, it should always be recorded. The apparent density of solids should be determined from measurement of the tube volume and sample mass.

12.3.2 If a mixture can separate out ~~during transport~~, the test should be performed with the initiator in contact with the potentially most explosive part, if known.

12.3.3 The tests ~~should be~~ performed at ambient temperature unless the substance is ~~to be transported under likely to encounter~~ conditions where it may change its physical state or density.

12.3.4 For organic substances and mixtures of organic substances with a decomposition energy of 800 J/g or more, test 2 (a) need not be performed if the outcome of the ballistic mortar Mk.IIIId test (F.1), or the ballistic mortar test (F.2) or the BAM Trauzl test (F.3) with initiation by a standard No. 8 detonator (see Appendix 1) is "No". In this case, the result of test 2 (a) is deemed to be "-". If the outcome of the F.1 or F.2 or F.3 test is "Low" or "Not low", the result of test 2 (a) shall be deemed "+". In this case, a "-" can only be obtained by performing test 2 (a).

**12.4 Series 2 type (a) test prescription****12.4.1 Test 2 (a): UN gap test**12.4.1.1 *Introduction*

This test is used to measure the sensitivity of a substance, under confinement in a steel tube, to detonative shock.

12.4.1.2 *Apparatus and materials*

The apparatus is shown in Figure 12.4.1.1. The test sample is contained in seamless, carbon steel tube with an external diameter of  $48 \pm 2$  mm, a wall thickness of 4 mm and a length of  $400 \pm 5$  mm. If the test substance may react with the steel, the inside of the tube may be coated with fluorocarbon resin. The bottom of the tube is closed a plastics sheet pulled tightly (so that it plastically deforms) over the bottom of the tube and held tightly in place. The plastics sheet shall be compatible with the substance under test. The booster charge consists of 160 g RDX/wax (95/5) or PETN/TNT that has a minimum of 50% PETN in the mixture,  $50 \pm 1$  mm in diameter with a density of  $1\,600 \pm 50$  kg/m<sup>3</sup>. The charges may be pressed in one or more pieces, as long as the total charge is within the specifications, and the PETN/TNT charge is cast. A polymethyl methacrylate (PMMA) spacer is required of diameter  $50 \pm 1$  mm and length  $50 \pm 1$  mm. A mild steel witness plate,  $150 \pm 10$  mm square and 3 mm thick, may be mounted at the upper end of the steel tube and separated from it by spacers  $1.6 \pm 0.2$  mm thick.

12.4.1.3 *Procedure*

12.4.1.3.1 The sample is loaded to the top of the steel tube. Solid samples are loaded to the density attained by tapping the tube until further settling becomes imperceptible. The sample mass is determined and, if solid, the apparent density calculated using the measured internal volume of the tube.

12.4.1.3.2 The tube is placed in a vertical position and the PMMA spacer placed in direct contact with the sheet which seals the bottom of the tube. After positioning the booster charge in contact with the PMMA spacer, the detonator is fixed in place against the bottom of the booster charge and initiated. Two tests should be performed unless detonation of the substance is observed.

12.4.1.4 *Test criteria and method of assessing results*

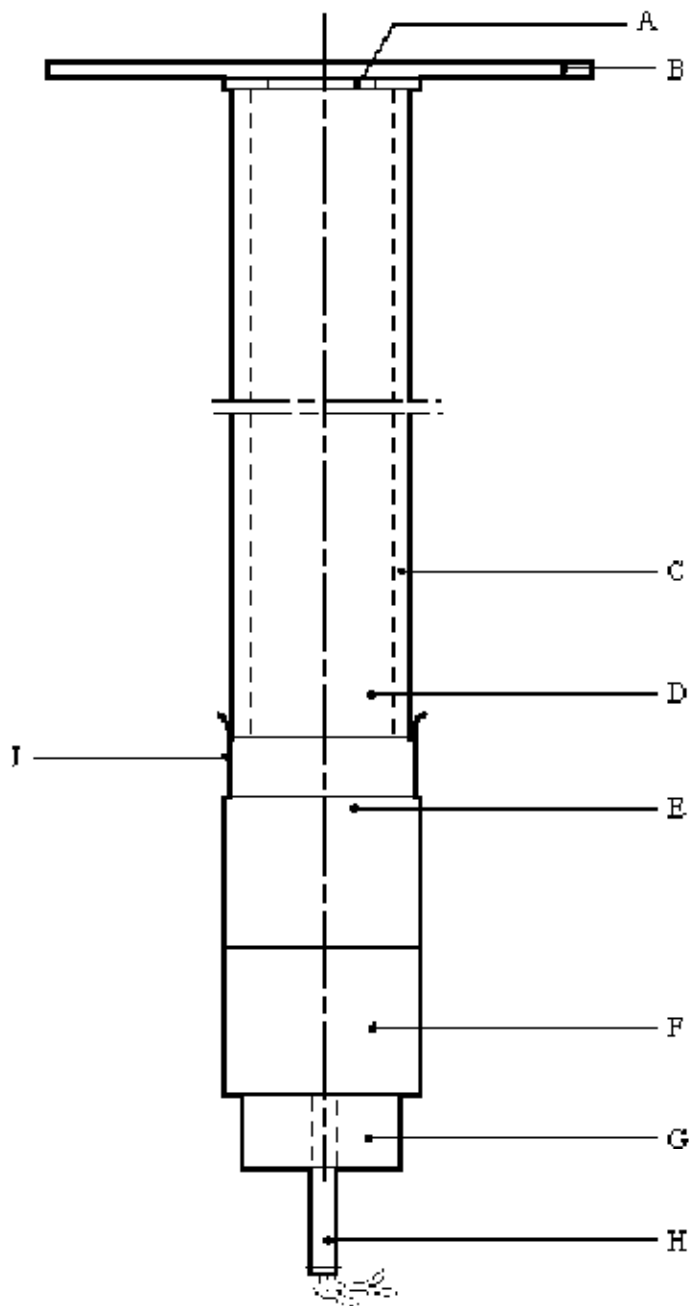
The test results are assessed on the basis of the type of fragmentation of the tube or whether the witness plate is holed. The test giving the most severe assessment should be used for classification. The test result is considered "+" and the substance to be sensitive to shock if:

- (a) The tube is fragmented completely; or
- (b) The witness plate is holed.

Any other result is considered "-" and the substance is considered to be not sensitive to detonative shock.

12.4.1.5 *Examples of results*

Substances	Apparent density (kg/m <sup>3</sup> )	Fragmentation length (cm)	Witness plate	Result
Ammonium nitrate, prills	800	25	Domed	-
Ammonium nitrate, 200 µm	540	40	Holed	+
Ammonium nitrate/fuel oil, 94/6	880	40	Holed	+
Ammonium perchlorate, 200 µm	1 190	0	No damage	-
Nitromethane	1 130	0	No damage	-
PETN/lactose, 20/80	880	40	Holed	+
TNT, cast	1 510	20	No damage	-
TNT, flaked	710	40	Holed	+



- 
- |     |                   |     |                                    |
|-----|-------------------|-----|------------------------------------|
| (A) | Spacers           | (B) | Witness plate                      |
| (C) | Steel tube        | (D) | Substance under investigation      |
| (E) | PMMA spacer       | (F) | RDX/wax or PETN/TNT booster charge |
| (G) | Detonator holder  | (H) | Detonator                          |
| (J) | Plastics membrane |     |                                    |
- 

**Figure 12.4.1.1: UN GAP TEST**



## 12.5 Series 2 type (b) test prescription

### 12.5.1 Test 2 (b): Koenen test

#### 12.5.1.1 Introduction

This test is used to determine the sensitiveness of solid and liquid substances to the effect of intense heat under high confinement.

#### 12.5.1.2 Apparatus and materials

12.5.1.2.1 The apparatus consists of a non-reusable steel tube, with its re-usable closing device, installed in a heating and protective device. The tube is deep drawn from sheet steel conforming to specification DC04 (EN 10027-1), or equivalent A620 (AISI/SAE/ASTM), or equivalent SPCEN (JIS g 3141). The dimensions are given in Figure 12.5.1.1. The open end of the tube is flanged. The closing plate with an orifice, through which the gases from the decomposition of the test substance escape, is made from heat-resisting chrome steel and is available with the following diameter holes: 1.0 - 1.5 - 2.0 - 2.5 - 3.0 - 5.0 - 8.0 - 12.0 - 20.0 mm. The dimensions of the threaded collar and the nut (closing device) are given in Figure 12.5.1.1.

For quality control of the steel tubes, 1% of the tubes from each production lot shall be subjected to quality control and the following data shall be verified:

- (a) The mass of the tubes shall be  $26.5 \pm 1.5$  g, tubes to be used in one test sequence shall not differ in mass by more than 1 g;
- (b) The length of the tubes shall be  $75 \pm 0.5$  mm;
- (c) The wall thickness of the tubes measured 20 mm from the bottom of the tube shall be  $0.5 \pm 0.05$  mm; and
- (d) The bursting pressure as determined by quasi-static load through an incompressible fluid shall be  $30 \pm 3$  MPa.

12.5.1.2.2 Heating is provided by propane, from an industrial cylinder fitted with a pressure regulator, via a flow meter and distributed by a manifold to the four burners. Other fuel gases may be used providing the specified heating rate is obtained. The gas pressure is regulated to give a heating rate of  $3.3 \pm 0.3$  K/s when measured by the calibration procedure. Calibration involves heating a tube (fitted with a 1.5 mm orifice plate) filled with 27 cm<sup>3</sup> of dibutyl phthalate. The time taken for the temperature of the liquid (measured with a 1 mm diameter thermocouple centrally placed 43 mm below the rim of the tube) to rise from 135 °C to 285 °C is recorded and the heating rate calculated.

12.5.1.2.3 Because the tube is likely to be destroyed in the test, heating is undertaken in a protective welded box, the construction and dimensions of which are given in Figure 12.5.1.2. The tube is suspended between two rods placed through holes drilled in opposite walls of the box. The arrangement of the burners is given in Figure 12.5.1.2. The burners are lit simultaneously by a pilot flame or an electrical ignition device. **The test apparatus is placed in a protective area.** Measures should be taken to ensure that the burner flames are not affected by any draughts. Provision should be made for extracting any gases or smoke resulting from the test.

#### 12.5.1.3 Procedure

12.5.1.3.1 Normally substances are tested as received, although in certain cases it may be necessary to test the substance after crushing it. For solids, the mass of material to be used in each test is determined using a two-stage dry run procedure. A tared tube is filled with 9 cm<sup>3</sup> of substance and the substance tamped<sup>1</sup> with 80 N force applied to the total cross-section of the tube. If the material is compressible then more is added and tamped until the tube is filled to 55 mm from the top. The total mass used to fill the tube to the 55 mm level is determined and two further increments,

<sup>1</sup> For reasons of safety, e.g. the substance is friction sensitive, the substance need not be tamped. In cases where the physical form of the sample can be changed by compression or compression of the sample is not related to the ~~transport~~ packaging conditions, e.g. for fibrous materials, more representative filling procedures may be used.

each tamped with 80 N force, are added. Material is then either added, with tamping, or taken out as required to leave the tube filled to a level 15 mm from the top.

A second dry run is performed, starting with a tamped increment a third of the total mass found in the first dry run. Two more of these increments are added with 80 N tamping and the level of the substance in the tube adjusted to 15 mm from the top by addition or subtraction of material as required. The amount of solid determined in the second dry run is used for each trial filling being performed in three equal increments, each compressed to 9 cm<sup>3</sup>. (This may be facilitated by the use of spacing rings.) Liquids and gels are loaded into the tube to a height of 60 mm taking particular care with gels to prevent the formation of voids. The threaded collar is slipped onto the tube from below, the appropriate orifice plate is inserted and the nut tightened by hand after applying some molybdenum disulphide based lubricant. It is essential to check that none of the substance is trapped between the flange and the plate, or in the threads.

12.5.1.3.2 With orifice plates from 1.0 mm to 8.0 mm diameter, nuts with an orifice of 10.0 mm diameter should be used; if the diameter of the orifice is above 8.0 mm, that of the nut should be 20.0 mm. Each tube is used for one trial only. The orifice plates, threaded collars and nuts may be used again provided they are undamaged.

12.5.1.3.3 The tube is placed in a rigidly mounted vice and the nut tightened with a spanner. The tube is then suspended between the two rods in the protective box. The test area is vacated, the gas supply turned on and the burners lit. The time to reaction and duration of reaction can provide additional information useful in interpreting the results. If rupture of the tube does not occur, heating is to be continued for at least five minutes before the trial is finished. After each trial the fragments of the tube, if any, should be collected and weighed.

12.5.1.3.4 The following effects are differentiated:

- "O": Tube unchanged;
- "A": Bottom of tube bulged out;
- "B": Bottom and wall of the tube bulged out;
- "C": Bottom of tube split;
- "D": Wall of tube split;
- "E": Tube split into two<sup>2</sup> fragments;
- "F": Tube fragmented into three<sup>2</sup> or more mainly large pieces which in some cases may be connected with each other by a narrow strip;
- "G": Tube fragmented into many mainly small pieces, closing device undamaged; and
- "H": Tube fragmented into many very small pieces, closing device bulged out or fragmented.

Examples for the effect types "D", "E" and "F" are shown in Figure 12.5.1.3. If a trial results in any of the effects "O" to "E", the result is regarded as "no explosion". If a trial gives the effect "F", "G" or "H", the result is evaluated as "explosion".

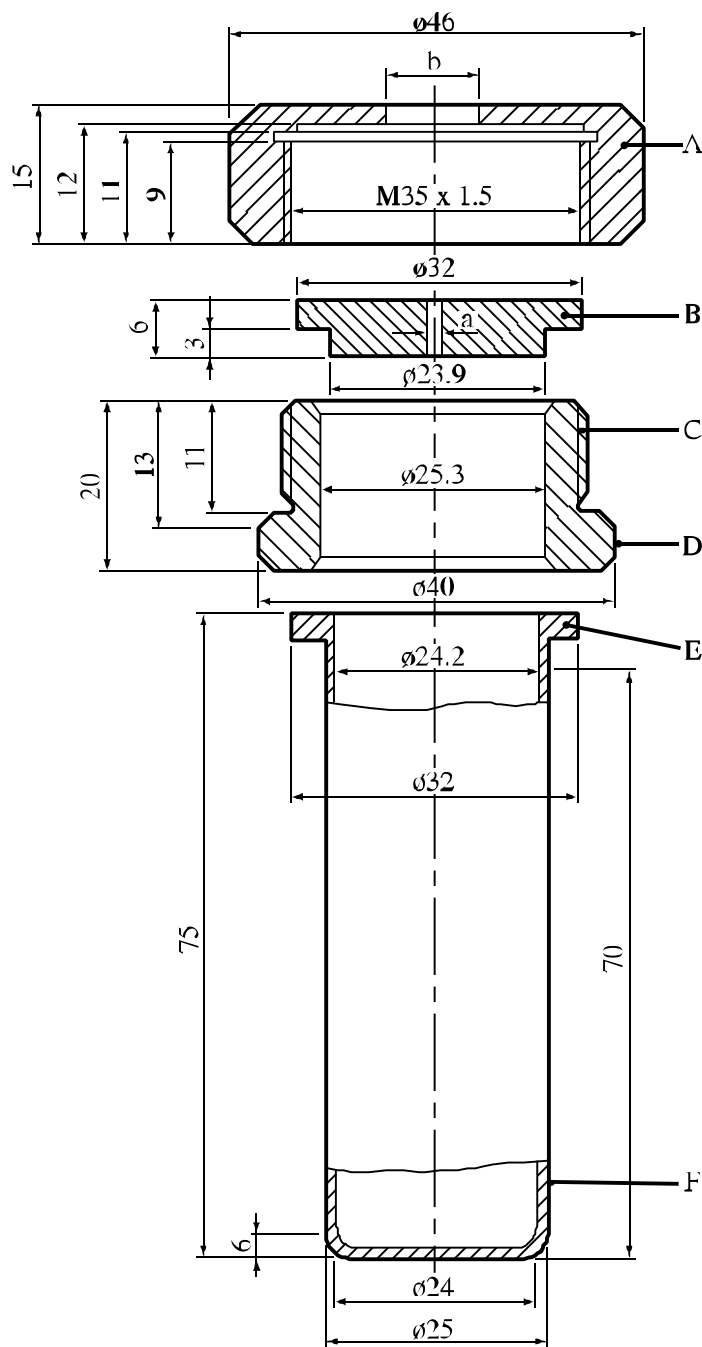
12.5.1.3.5 The series of trials is started with a single trial using an orifice plate of 20.0 mm. If, in this trial, the result "explosion" is observed, the series is continued with trials using tubes without orifice plates and nuts but with threaded collars (orifice 24.0 mm). If at 20.0 mm "no explosion" occurs, the series is continued with single trials using plates with the following orifices 12.0 - 8.0 - 5.0 - 3.0 - 2.0 - 1.5 and finally 1.0 mm until, at one of these diameters, the result "explosion" is obtained. Subsequently, trials are carried out at increasing diameters, according to the sequence given in 12.5.1.2.1, until only negative results in three tests at the same level are obtained. The limiting diameter of a substance is the largest diameter of the orifice at which the result "explosion" is obtained. If no "explosion" is obtained with a diameter of 1.0 mm, the limiting diameter is recorded as being less than 1.0 mm.

12.5.1.4 *Test criteria and method of assessing results*

The result is considered "+" and the substance to show a violent effect on heating under confinement if the limiting diameter is 2.0 mm or more. The result is considered "-" and the substance to show no violent effect on heating under confinement if the limiting diameter is less than 2.0 mm.

12.5.1.5 *Examples of results*

<b>Substances</b>	<b>Limiting diameter (mm)</b>	<b>Result</b>
Ammonium nitrate (crystalline)	1.0	-
Ammonium perchlorate	3.0	+
Ammonium picrate (crystalline)	2.5	+
1,3-Dinitroresorcinol (crystalline)	2.5	+
Guanidine nitrate (crystalline)	1.5	-
Picric acid (crystalline)	4.0	+
PETN/wax (95/5)	5.0	+



- |     |  |     |   |
|-----|--|-----|---|
| (A) | Nut ( $b = 10.0$ or $20.0$ mm)<br>with flats for size 41 spanner | (B) | Orifice plate ( $a = 1.0 \rightarrow 20.0$ mm diameter) |
| (C) | Threaded collar  | (D) | Flats for size 36 spanner                               |
| (E) | Flange   | (F) | Tube  |

Figure 12.5.1.1: TEST TUBE ASSEMBLY

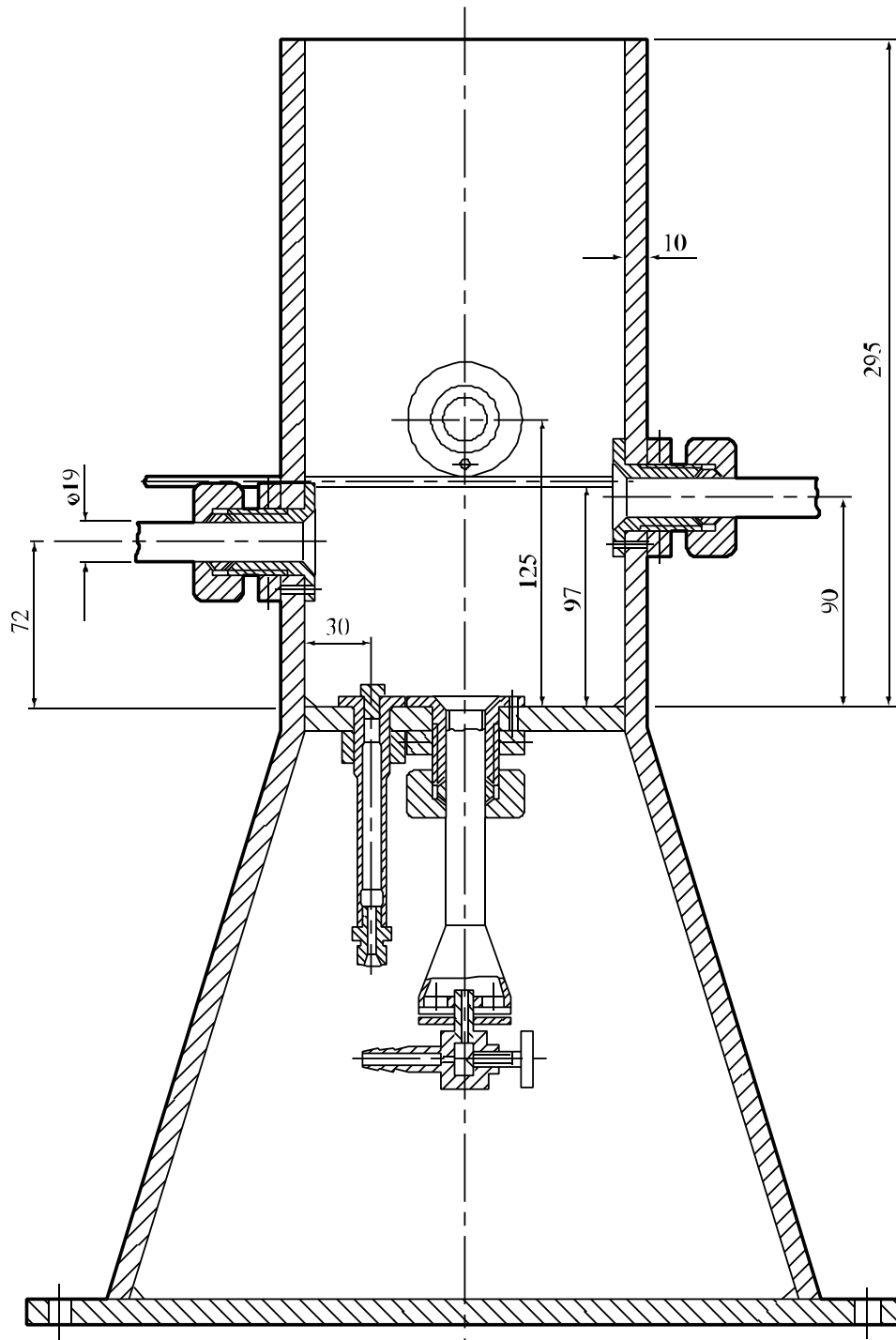


Figure 12.5.1.2: HEATING AND PROTECTIVE DEVICE

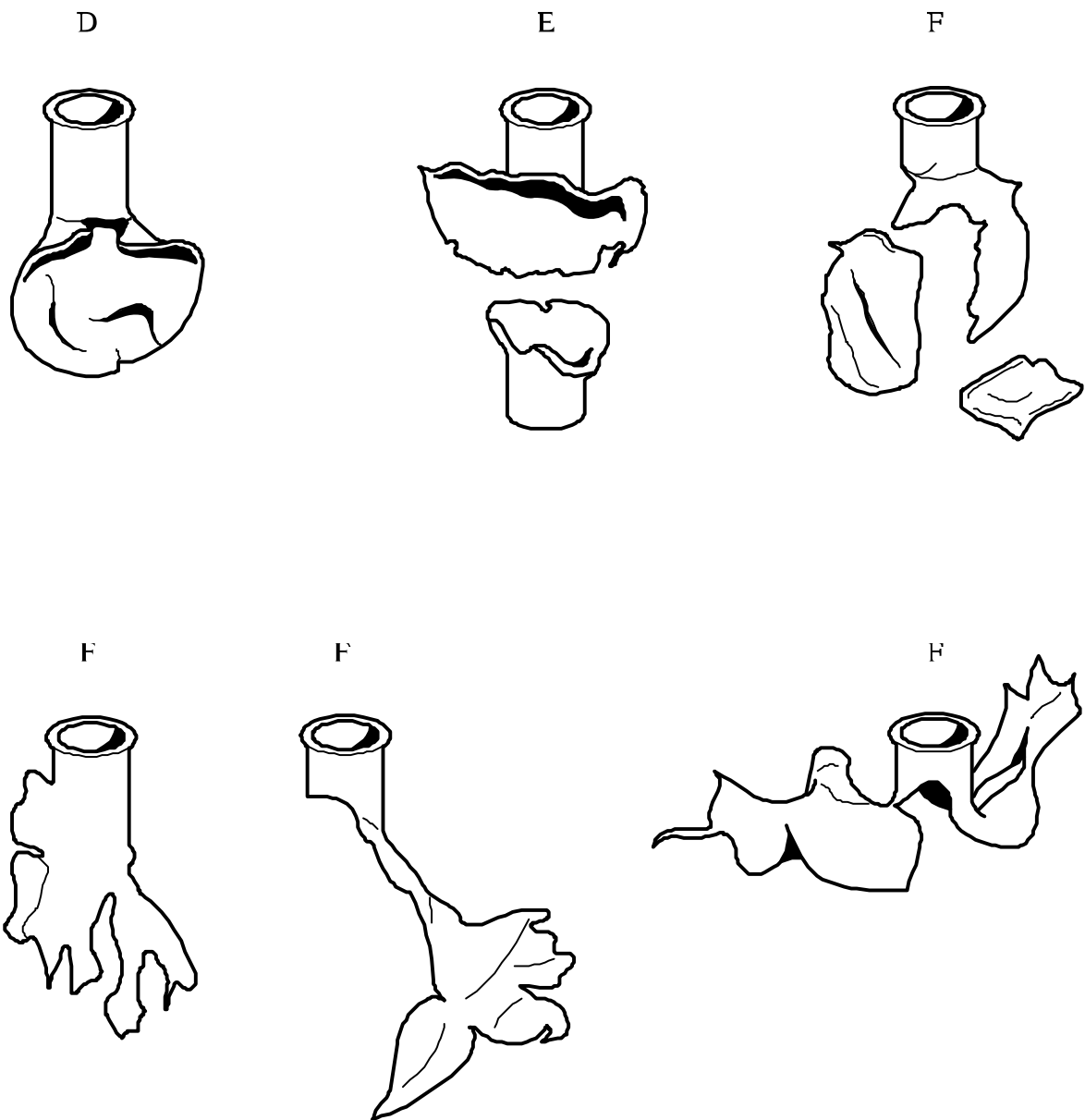


Figure 12.5.1.3 EXAMPLES OF EFFECT TYPES D, E AND F

**12.6 Series 2 type (c) test prescriptions****12.6.1 Test 2 (c) (i): Time/pressure test**12.6.1.1 *Introduction*

This test is used to determine the effects of igniting the substance<sup>3</sup> under confinement in order to determine if ignition leads to a deflagration with explosive violence at pressures which can be attained with substances in normal commercial packages.

12.6.1.2 *Apparatus and materials*

12.6.1.2.1 The time/pressure apparatus (Figure 12.6.1.1) consists of a cylindrical steel pressure vessel 89 mm in length and 60 mm in external diameter. Two flats are machined on opposite sides (reducing the cross-section of the vessel to 50 mm) to facilitate holding whilst fitting the firing plug and vent plug. The vessel, which has a bore of 20 mm diameter, is internally rebated at either end to a depth of 19 mm and threaded to accept 1" British Standard Pipe (BSP). A pressure take-off, in the form of a side-arm, is screwed into the curved face of the pressure vessel 35 mm from one end and at 90° to the machined flats. The socket for this is bored to a depth of 12 mm and threaded to accept the 1/2" BSP thread on the end of the side-arm. A washer is fitted to ensure a gastight seal. The side-arm extends 55 mm beyond the pressure vessel body and has a bore of 6 mm. The end of the side-arm is rebated and threaded to accept a diaphragm type pressure transducer. Any pressure-measuring device may be used provided that it is not affected by the hot gases or decomposition products and is capable of responding to rates of pressure rise of 690-2 070 kPa in not more than 5 ms.

12.6.1.2.2 The end of the pressure vessel furthest from the side-arm is closed with a firing plug which is fitted with two electrodes, one insulated from and the other earthed to, the plug body. The other end of the pressure vessel is closed by an aluminium bursting disc 0.2 mm thick (bursting pressure approximately 2 200 kPa) held in place with a retaining plug which has a 20 mm bore. A soft lead washer or a washer of a suitable deformable material (for example, polyoxymethylene) is used with both plugs to ensure a good seal. A support stand (Figure 12.6.1.2) holds the assembly in the correct attitude during use. This comprises a mild steel base plate measuring 235 mm × 184 mm × 6 mm and a 185 mm length of square hollow section (S.H.S.) 70 × 70 × 4 mm.

12.6.1.2.3 A section is cut from each of two opposite sides at one end of the length of S.H.S. so that a structure having two flat sided legs surmounted by an 86 mm length of intact box section results. The ends of these flat sides are cut to an angle of 60° to the horizontal and welded to the base plate.

12.6.1.2.4 A slot measuring 22 mm wide × 46 mm deep is machined in one side of the upper end of the base section such that when the pressure vessel assembly is lowered, firing plug end first, into the box section support, the side-arm is accommodated in this slot. A packing piece of steel 30 mm wide and 6 mm thick is welded to the lower internal face of the box section to act as a spacer. Two 7 mm thumb screws, tapped into the opposite face, serve to hold the pressure vessel firmly in place. Two 12 mm wide strips of 6 mm thick steel, welded to the side pieces abutting the base of the box section, support the pressure vessel from beneath.

12.6.1.2.5 The ignition system consists of an electric fusehead of the type commonly used in low tension detonators, together with a 13 mm square piece of primed cambric. Fuseheads with equivalent properties may be used. Primed cambric consists of a linen fabric coated on both sides with a potassium nitrate/silicon/sulphurless gunpowder pyrotechnic composition<sup>4</sup>.

12.6.1.2.6 The procedure for the preparation of the ignition assembly for solids starts with separation of the brass foil contacts of an electric fusehead from its insulator, (see Figure 12.6.1.3). The exposed portion of insulation is then cut off. The fusehead is then fixed onto the terminals of the firing plug by means of the brass contacts such that the tip of the fusehead is 13 mm above the surface of the firing plug. A 13 mm square piece of primed cambric is pierced through the centre and positioned over the attached fusehead around which it is then folded and secured with fine cotton thread.

<sup>3</sup> When testing thermally stable energetic liquids, such as nitromethane (UN 1261), variable results may be obtained because the substance may give two pressure peaks.

<sup>4</sup> Obtainable from the national contact for test details in United Kingdom (see Appendix 4).

12.6.1.2.7 For liquids samples, leads are fixed onto the contact foils of the fusehead. The leads are then threaded through an 8 mm length of 5 mm outer diameter and 1 mm inner diameter silicone rubber tubing and the tubing is pushed up over the fusehead contact foils as shown in Figure 12.6.1.4. The primed cambric is then wrapped around the fusehead and a single piece of thin PVC sheathing, or equivalent, is used to cover the primed cambric and the silicone rubber tubing. The sheathing is sealed in position by twisting a length of thin wire tightly round the sheathing and rubber tubing. The leads are then fixed onto the terminals of the firing plug such that the tip of the fusehead is 13 mm above the surface of the firing plug.

#### 12.6.1.3 *Procedure*

12.6.1.3.1 The apparatus, assembled complete with pressure transducer but without the aluminium bursting disc in position, is supported firing plug end down. 5.0 g<sup>5</sup> of the substance is introduced into the apparatus so as to be in contact with the ignition system. Normally no tamping is carried out when filling the apparatus unless it is necessary to use light tamping in order to get the 5.0 g charge into the vessel. If, even with light tamping, it is impossible to get all the 5.0 g of sample in, then the charge is fired after filling the vessel to capacity. Note should be taken of the charge weight used. The lead washer and aluminium bursting disc are placed in position and the retaining plug is screwed in tightly. The charged vessel is transferred to the firing support stand, bursting disc uppermost, which should be contained in a suitable, armoured fume cupboard or firing cell. An exploder dynamo is connected to the external terminals of the firing plug and the charge is fired. The signal produced by the pressure transducer is recorded on a suitable system which allows both evaluation and a permanent record of the time/pressure profile to be achieved (e.g. transient recorder coupled to a chart-recorder).

12.6.1.3.2 The test is carried out three times. The time taken for the pressure to rise from 690 kPa to 2 070 kPa above atmospheric is noted. The shortest time interval should be used for classification.

#### 12.6.1.4 *Test criteria and method of assessing results*

The test results are interpreted in terms of whether a gauge pressure of 2 070 kPa is reached and, if so, the time taken for the pressure to rise from 690 kPa to 2 070 kPa gauge.

The result is considered "+" and the substance to show the ability to deflagrate rapidly if the time for a pressure rise from 690 kPa to 2 070 kPa is less than 30 ms. The result is considered "-" and the substance to show no or slow deflagration if the rise time is 30 ms or more or a pressure of 2 070 kPa gauge is not reached. Failure to ignite does not necessarily indicate that the substance has no explosive properties.

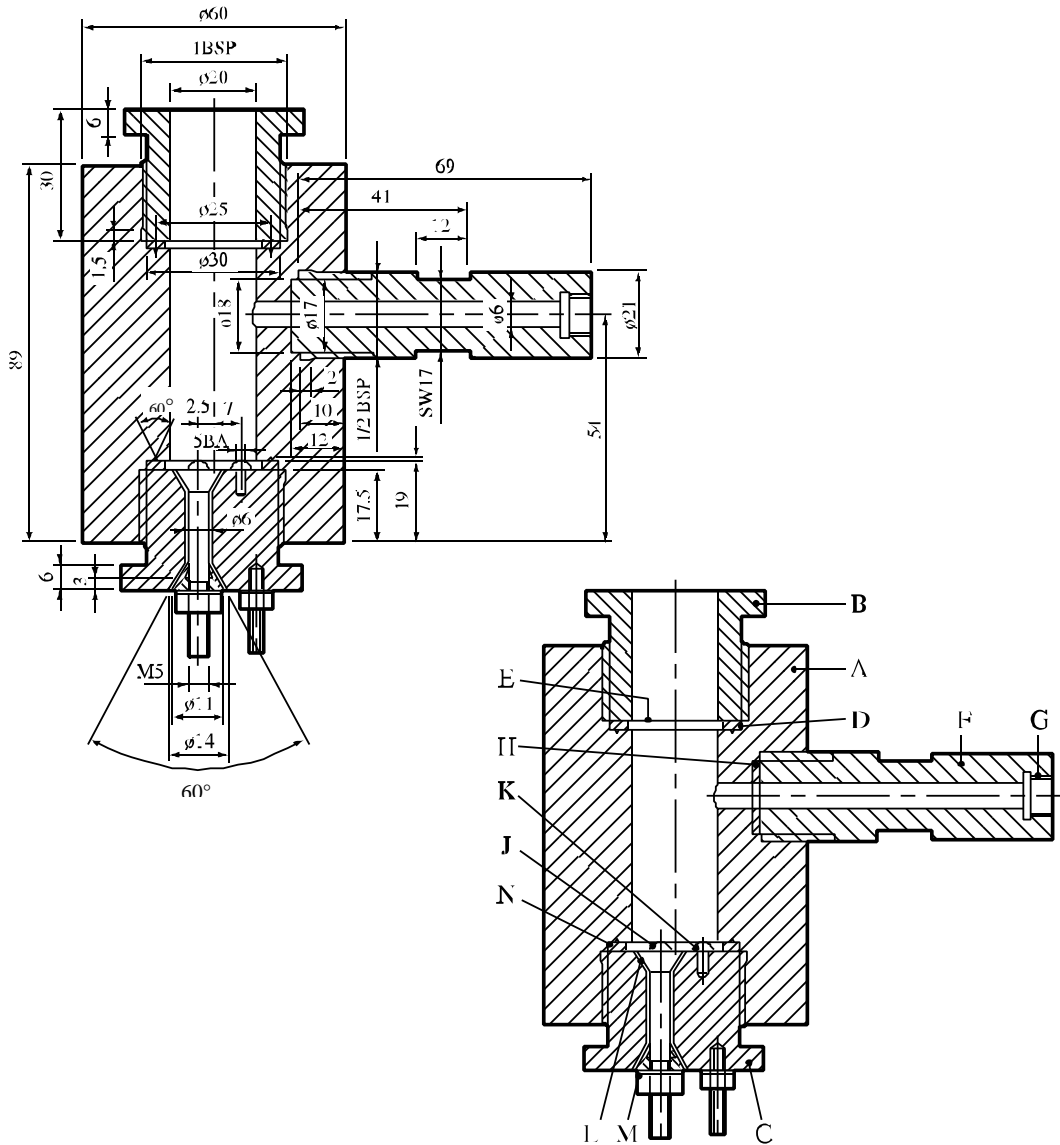
---

<sup>5</sup> ***If preliminary safety-in-handling tests (e.g. heating in a flame) or unconfined burning tests (e.g. a Series 3 type (d) test) indicate that a rapid reaction is likely to occur, then the sample size should be reduced to 0.5 g until the severity of the confined reaction is known. If it is necessary to use a 0.5 g sample, the sample size should be gradually increased until either a "+" result is obtained or the test is performed with a 5.0 g sample.***



12.6.1.5 *Examples of results*

<b>Substances</b>	<b>Maximum pressure (kPa)</b>	<b>Time for a pressure rise from 690 to 2 070 kPa (ms)</b>	<b>Result</b>
Ammonium nitrate (high density prills)	< 2 070	-	-
Ammonium nitrate (low density prills)	< 2 070	-	-
Ammonium perchlorate (2 µm)	> 2 070	5	+
Ammonium perchlorate (30 µm)	> 2 070	15	+
Barium azide	> 2 070	<5	+
Guanidine nitrate	> 2 070	606	-
Isobutyl nitrite	> 2 070	80	-
Isopropyl nitrate	> 2 070	10	+
Nitroguanidine	> 2 070	400	-
Picramic acid	> 2 070	500	-
Sodium picramate	> 2 070	15	+
Urea nitrate	> 2 070	400	-



- |                                |                                  |
|--------------------------------|----------------------------------|
| (A) Pressure vessel body       | (B) Bursting disc retaining plug |
| (C) Firing plug                | (D) Soft lead washer             |
| (E) Bursting disc              | (F) Side arm                     |
| (G) Pressure transducer thread | (H) Copper washer                |
| (J) Insulated electrode        | (K) Earthed electrode            |
| (L) Insulation                 | (M) Steel cone                   |
| (N) Washer distorting groove   |                                  |

Figure 12.6.1.1: APPARATUS

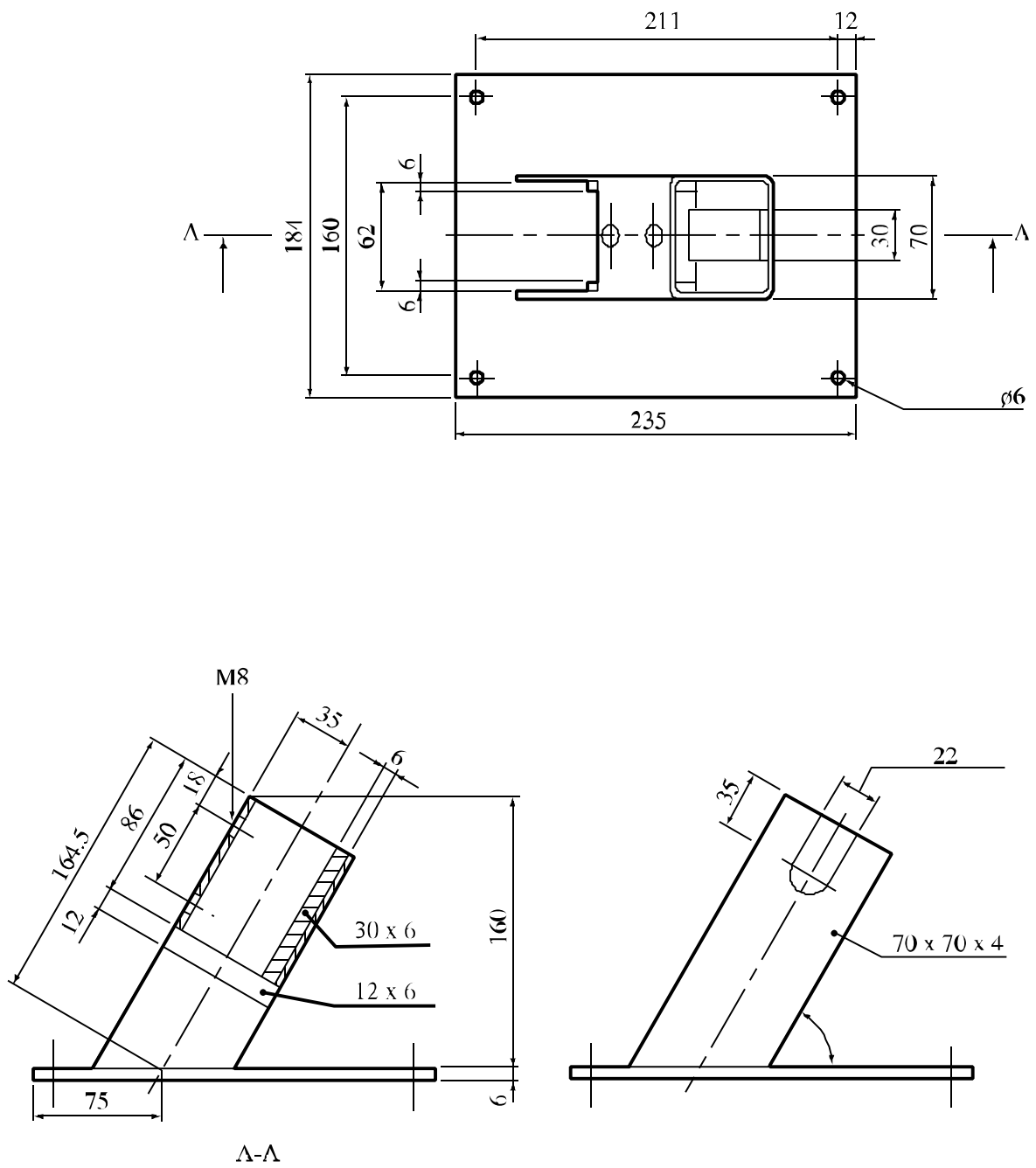
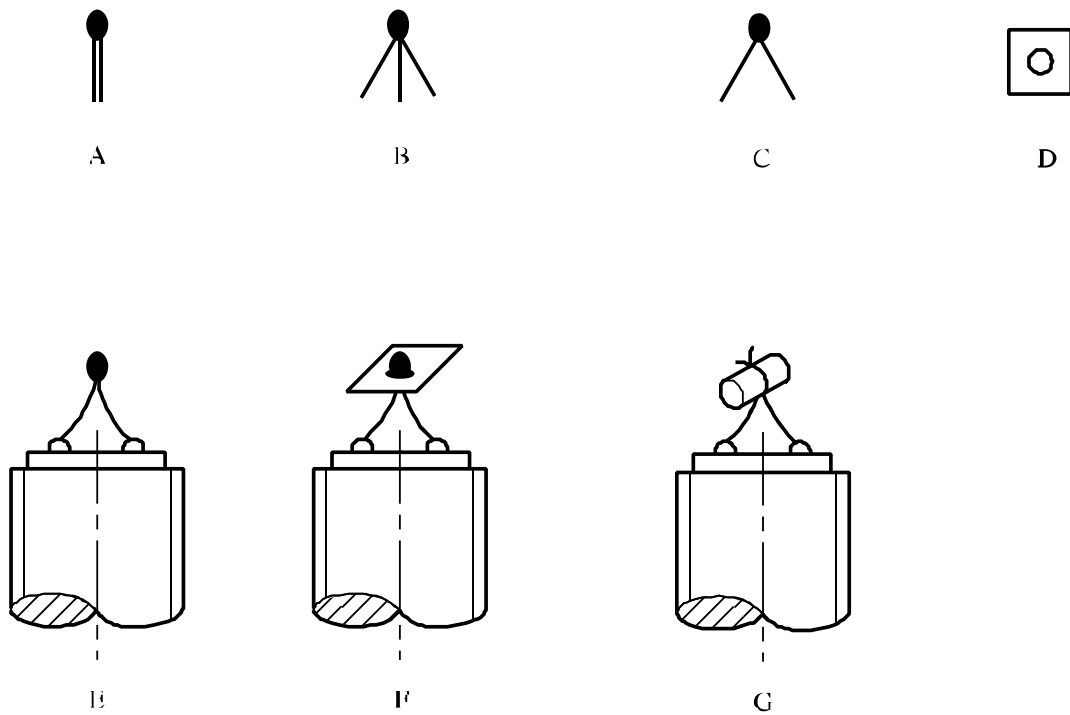
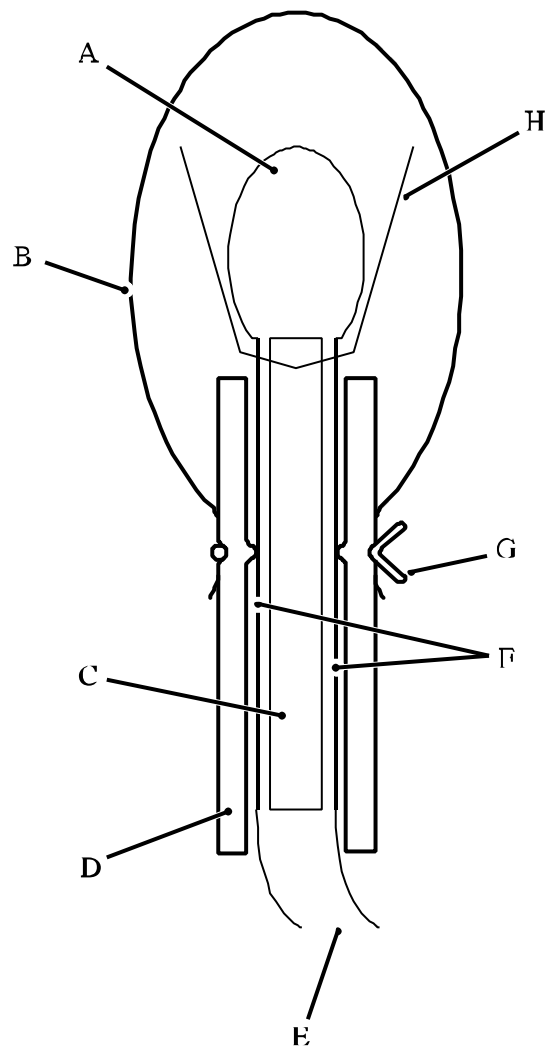


Figure 12.6.1.2: SUPPORT STAND



- 
- (A) Electrically ignited fusehead as manufactured
  - (B) Brass foil contacts parted from card insulator
  - (C) Insulating card cut off
  - (D) Primed cambric SR252 13 mm square with centre hole
  - (E) Fusehead fixed to pins on firing plug
  - (F) Cambric positioned on fusehead
  - (G) Cambric folded around and tied with thread
- 

**Figure 12.6.1.3: IGNITION SYSTEM FOR SOLIDS**



- (A) Fusehead
- (B) PVC sheath
- (C) Insulating card
- (D) Silicone rubber tubing
- (E) Firing leads
- (F) Foil contacts
- (G) Wire to make liquid-tight seal
- (H) Primed cambric

Figure 12.6.1.4: IGNITION SYSTEM FOR LIQUIDS

---

**12.6.2**            *Test 2 (c) (ii): Internal ignition test*

12.6.2.1           *Introduction*

This test is used to determine the tendency of a substance to undergo transition from deflagration to detonation.

12.6.2.2           *Apparatus and materials*

The experimental arrangement is shown in Figure 12.6.2.1. The sample of substance to be tested is contained in a 45.7 cm length of "3 inch schedule 80" carbon (A53 Grade B) steel pipe with inside diameter 74 mm, wall thickness 7.6 mm, capped at both ends with a "3 000 pound" forged steel pipe cap. An igniter consisting of 10 g of black powder (100% passed through No. 20 sieve, 0.84 mm, and 100% retained by No. 50 sieve, 0.297 mm) is located at the centre of the sample vessel. The igniter assembly consists of a cylindrical container 21 mm in diameter and 32 mm long which is made from 0.54 mm thick cellulose acetate which is held together by two layers of nylon filament reinforced cellulose acetate tape. The igniter capsule contains a small loop formed from a 25 mm length of nickel-chromium alloy resistance wire 0.30 mm in diameter having a resistance of 0.35 ohms. This loop is attached to two insulated tinned copper lead wires 0.7 mm in diameter. The overall wire diameter, including insulation, is 1.3 mm. These lead wires are fed through small holes in the wall of the pipe and are sealed with epoxy resin.

12.6.2.3           *Procedure*

After the sample, at ambient temperature, is loaded into the pipe to a height of 23 cm, the igniter (with its leads inserted through small holes in the pipe wall) is inserted into the centre of the pipe and the leads pulled taut and sealed with epoxy resin. The remainder of the sample is then loaded and the top cap screwed on. For gelatinous samples, the substance is packed as near as possible to its normal shipping density. For granular samples, the substance is loaded to the density obtained by repeated tapping of the pipe against a hard surface. The tube is placed in a vertical position and the igniter is fired by a current of 15 amperes obtained from a 20-volt transformer. Three trials should be performed unless deflagration to detonation transition occurs earlier.

12.6.2.4           *Test criteria and method of assessing results*

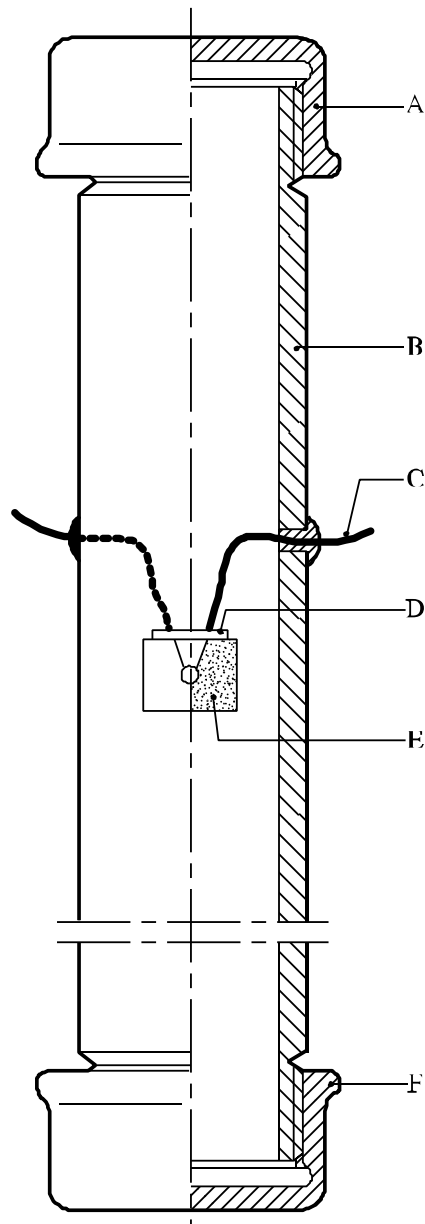
The test result is considered "+" if either the pipe or at least one of the end caps is fragmented into at least two distinct pieces. Results in which the pipe is merely split or laid open, or in which the pipe or caps are distorted to the point at which the caps are blown off, are considered "-".

12.6.2.5           *Examples of results*

---

<b>Substance</b>	<b>Results</b>
Ammonium nitrate/fuel oil, aluminised	-
Ammonium nitrate prills, porous, low density	-
Ammonium perchlorate (45 µm)	+
1,3-Dinitrobenzene, fine crystals	-
Nitrocarbonitrate	-
TNT, granular	+
Watergel	+

---



- |                      |                      |
|----------------------|----------------------|
| (A) Forged steel cap | (B) Steel pipe       |
| (C) Igniter leads    | (D) Seal             |
| (E) Igniter assembly | (F) Forged steel cap |

Figure 12.6.2.1: INTERNAL IGNITION TEST





## SECTION 13

## TEST SERIES 3

## 13.1 Introduction

The questions "Is the substance thermally stable?" (box 10 of Figure 10.2) and "Is the substance ~~too dangerous for transport~~ unstable in the form in which it was tested?" (box 11 of Figure 10.2) are answered by determining the sensitiveness of the substance to mechanical stimuli (impact and friction), to heat and to flame. The question in box 10 is answered "no" if a "+" is obtained in test type 3(c) and the substance ~~is considered too unstable~~ shall be classified as an unstable explosive and is not permitted for ~~to~~ transport. The question in box 11 is answered "yes" if a "+" is obtained in any of the test types 3(a), 3(b) or 3(d). If a "+" is obtained, the substance shall be classified as an unstable explosive in the form in which it was tested but may be encapsulated or otherwise desensitized or packaged to reduce its sensitiveness to external stimuli.

## 13.2 Test methods

Test Series 3 comprises four types of test:

- Type 3 (a): for determining sensitiveness to impact;
- Type 3 (b): for determining sensitiveness to friction (including impacted friction);
- Type 3 (c): for determining the thermal stability of a substance; and
- Type 3 (d): for determining the response of the substance to fire.

The test methods currently used are listed in Table 13.1.

**Table 13.1: TEST METHODS FOR TEST SERIES 3**

Test code	Name of Test	Section
3 (a) (i)	Bureau of Explosives impact machine	13.4.1
3 (a) (ii)	BAM Fallhammer <sup>a</sup>	13.4.2
3 (a) (iii)	Rotter test	13.4.3
3 (a) (iv)	30 kg Fallhammer test	13.4.4
3 (a) (v)	Modified type 12 impact tool	13.4.5
3 (a) (vi)	Impact sensitivity test	13.4.6
3 (a) (vii)	Modified Bureau of Mines impact machine test	13.4.7
3 (b) (i)	BAM friction apparatus <sup>a</sup>	13.5.1
3 (b) (ii)	Rotary friction test	13.5.2
3 (b) (iii)	Friction sensitivity test	13.5.3
3 (b) (iv)	ABL friction machine test	13.5.4
3 (c) (i)	Thermal stability test at 75 °C <sup>a</sup>	13.6.1
3 (c) (ii)	SBAT thermal stability test at 75 °C	13.6.2
3 (d)	Small-scale burning test <sup>a</sup>	13.7.1

<sup>a</sup> *Recommended test.*

## 13.3 Test conditions

13.3.1 *Care must be taken if it is necessary to crush or cut explosive samples before use. Protective equipment, e.g. safety screens, should be used and the quantities kept to the minimum.*

13.3.2 For tests of types 3 (a) and (b), wetted substances should be tested with the minimum content of wetting agent ~~provided for transport~~.

13.3.3 Test types 3 (a) and 3 (b) should be performed at ambient temperature unless ~~otherwise specified or the substance is to be transported under~~likely to encounter conditions where it may change its physical state.

13.3.4 To obtain reproducible results, all factors of test types 3 (a) and 3 (b) should be carefully controlled and a suitable standard of known sensitiveness should be tested periodically.

13.3.5 Entrapped air bubbles render liquid substances much more sensitive to impact and hence test type 3 (a) methods for liquids employ special tools or procedures which allow the "adiabatic" compression of such bubbles in the liquid.

13.3.6 Tests of type 3 (b) need not be applied to liquids.

## **13.4 Series 3 type (a) test prescriptions**

### **13.4.1 Test 3 (a) (i): Bureau of Explosives impact machine**

#### *13.4.1.1 Introduction*

This test is used to measure the sensitiveness of a substance to drop-weight impact and to determine if the substance is ~~too dangerous to transport~~unstable in the form tested. It is applicable to solid and liquid substances by using two different sample assemblies.

#### *13.4.1.2 Apparatus and materials*

##### *13.4.1.2.1 Solids*

Drawings of the apparatus for the impact test of solids are shown in figures 13.4.1.1 and 13.4.1.2. The apparatus is designed so that a weight of mass 3.63 kg is free to fall between two parallel cylindrical guide rods, from pre-selected heights, onto a plunger-and-plug assembly. This assembly is in contact with the sample, which in turn is placed on a die-and-anvil assembly and confined in a cylindrical casing whose inside diameter is just sufficient to permit free movement of the plunger and plug. The plunger, plug, die, casing and anvil are hardened tool steel of hardness 50-55 on the Rockwell C scale and the mating surfaces and the surfaces in contact with the sample have a finish of 0.8 microns. The sample holder diameter is 5.1 mm.

##### *13.4.1.2.2 Liquids*

The apparatus for the impact test of liquid is similar to that for solids, except for the sample assembly. The sample assembly for testing liquids is shown in Figure 13.4.1.3.

#### *13.4.1.3 Procedure*

##### *13.4.1.3.1 Solids*

A 10 mg sample is loaded onto the die (C). The anvil (E) and die are placed in the sample housing (F) and the casing (D) screwed down over them. The plug (B) and plunger (A) are then inserted on top of the sample. The drop weight is raised to a height of 10.0 cm and released. Observations are made on whether an "explosion" occurs as evidenced by a flame or audible report. Ten trials are performed for each test sample.

##### *13.4.1.3.2 Liquids*

The rebound sleeve (A), the intermediate pin (B), and the striker (D) are assembled in the striker housing (C). A copper cup (E) is placed in the cup positioning block (not shown in Figure 13.4.1.3) and one drop of the liquid under test is placed in the cup (E). The housing (C) and its components (A, B and D) are placed over the top of the cup positioning block. The end of the striker (D) slips partway into the cup (E), but is prevented by the cup positioning block from actually touching the liquid in the cup. When the striker housing is lifted from the positioning block, the cup is held on the end of the striker by friction. The striker housing is then screwed down into the anvil housing and the dimensions of the tools are such that the bottom of the copper cup just touches the anvil when the

striker housing is screwed in hand-tight. The whole unit is then placed in the same drop weight mechanism used for solids. The drop weight is raised to a height of 25.0 cm and released. Observations are made on whether an "explosion" occurs as evidenced by smoke, flame or audible report. Ten trials are performed for each test sample.

13.4.1.4 *Test criteria and method of assessing results*

13.4.1.4.1 Solids

The test result is considered "+" if a flame or an audible report is observed in at least 5 out of 10 trials at a drop height of 10 cm and the substance is considered ~~too dangerous for transport~~ unstable in the form in which it was tested. Otherwise, the result is considered "-". Borderline cases may be resolved using the Bruceton method (see Appendix 2).

13.4.1.4.2 Liquids

The test result is considered "+" if smoke, flame or an audible report is observed in at least 1 out of 10 trials at a drop height of 25 cm and the substance is considered ~~too dangerous for transport~~ unstable in the form in which it was tested. Otherwise, the result is considered "-".

13.4.1.5 *Examples of results*

13.4.1.5.1 Solids

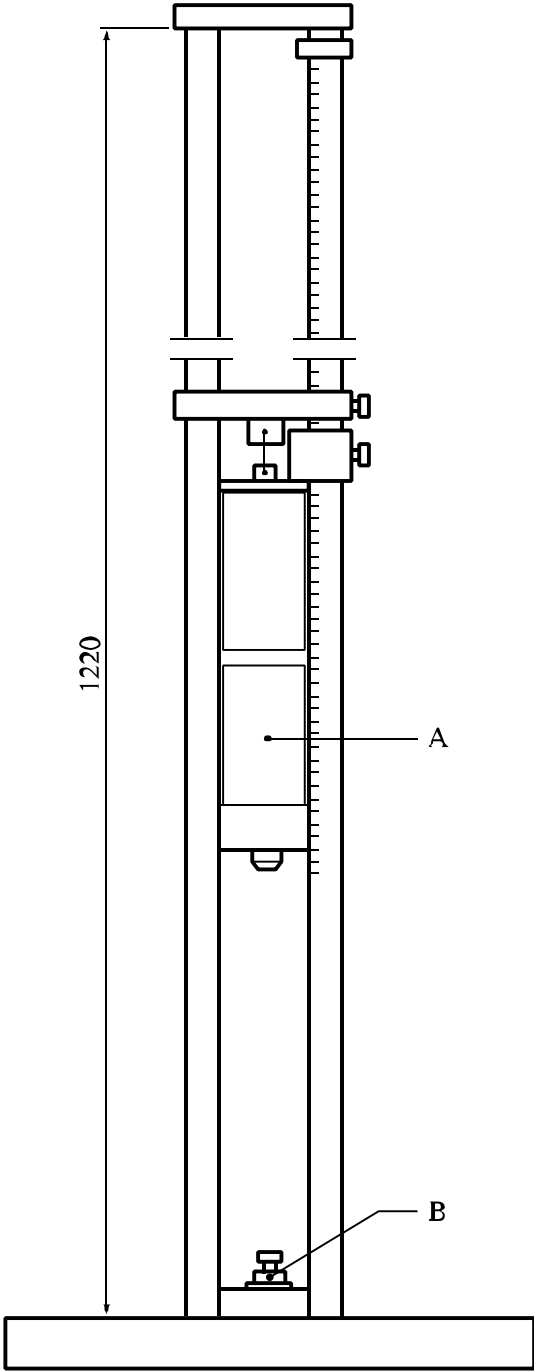
Results from tests to determine the impact sensitiveness of solid:

Test sample	Result
Ammonium perchlorate	-
HMX, (dry)	+
NG Dynamite	-
PETN, (dry)	+
PETN/water, (75/25)	-
RDX, (dry)	+

13.4.1.5.2 Liquids

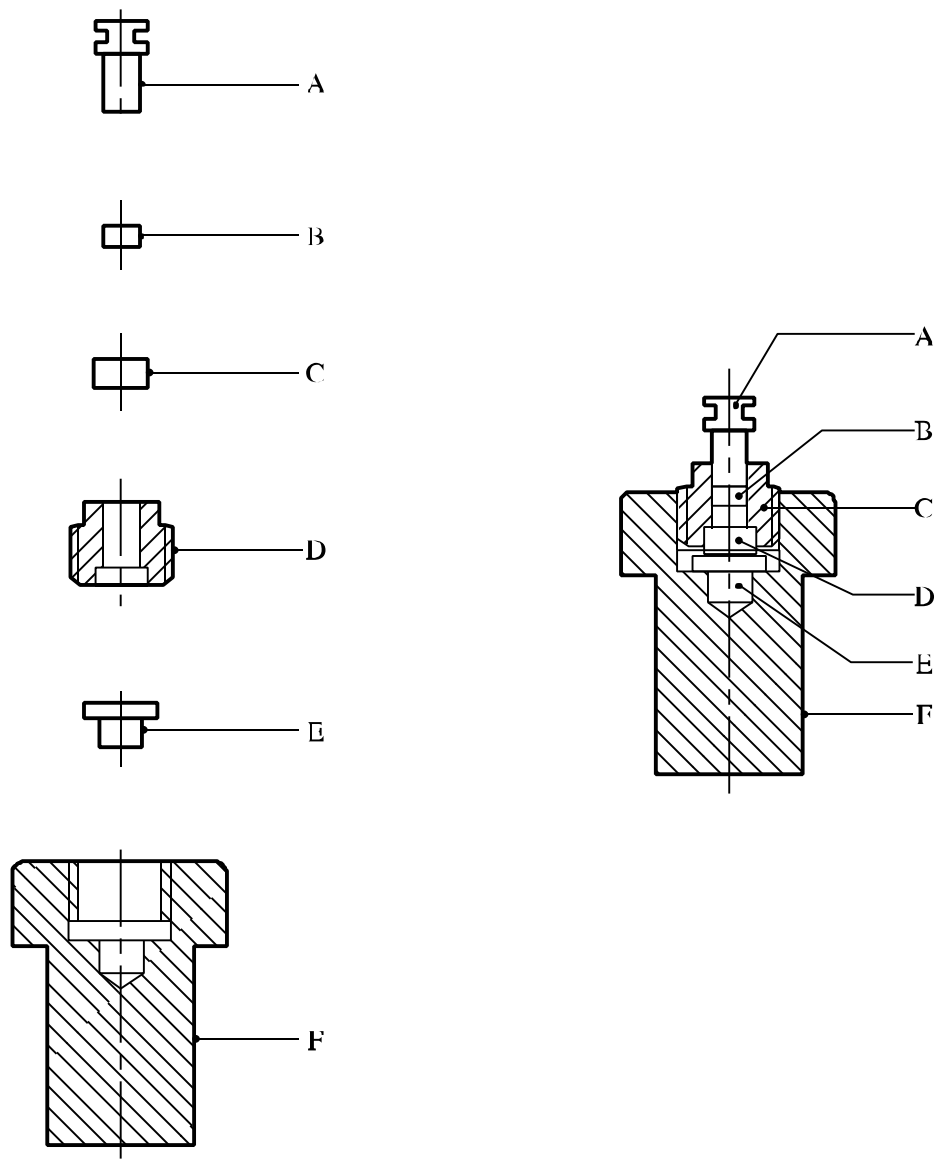
Results from tests to determine the impact sensitiveness of liquids:

Test sample	Result
NG	+
Nitromethane	-



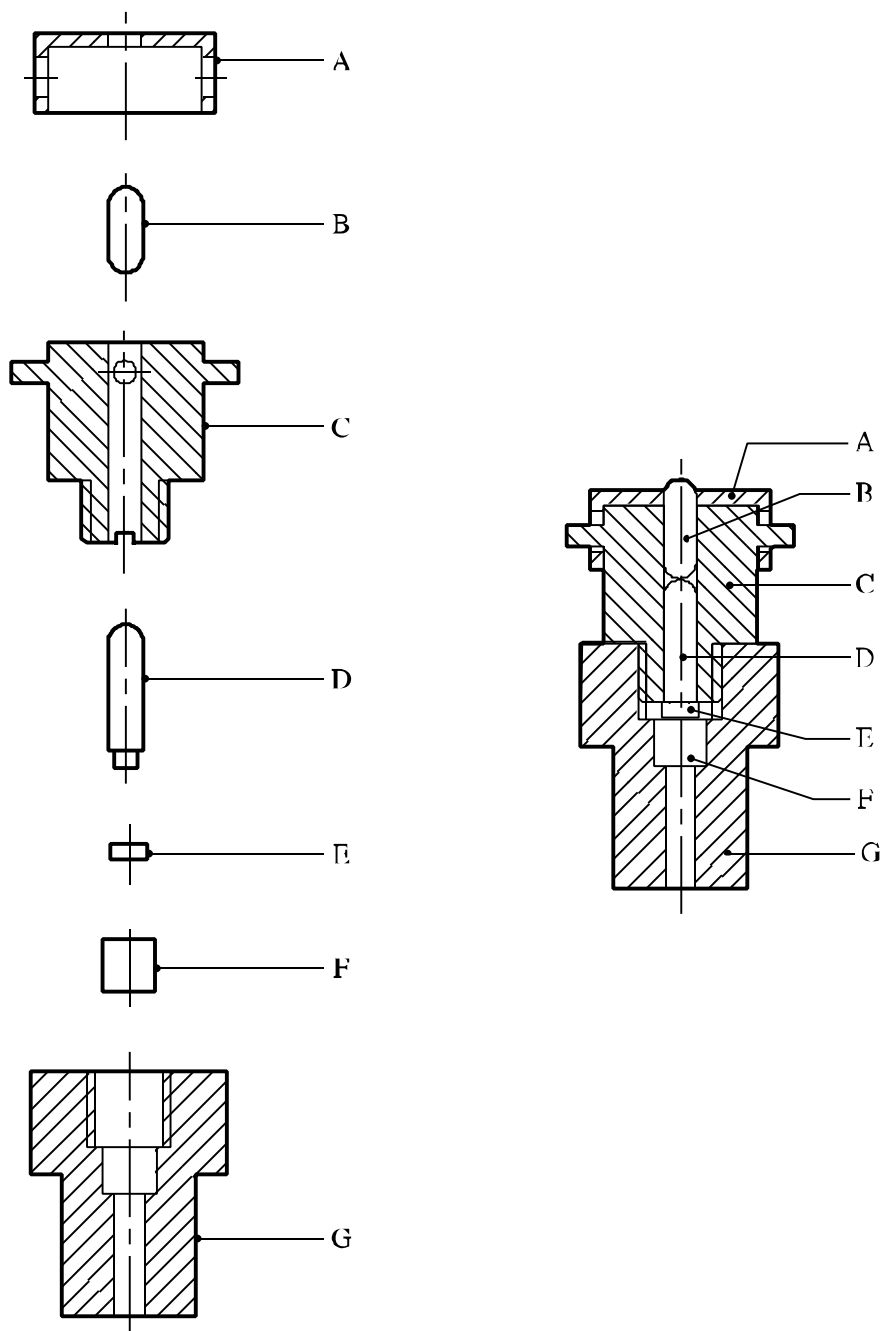
- 
- (A) Drop weight
  - (B) Sample assembly
- 

**Figure 13.4.1.1: BUREAU OF EXPLOSIVES IMPACT MACHINE**



- |     |         |     |         |
|-----|---------|-----|---------|
| (A) | Plunger | (B) | Plug    |
| (C) | Die     | (D) | Casing  |
| (E) | Anvil   | (F) | Housing |

Figure 13.4.1.2: SAMPLE ASSEMBLY FOR SOLIDS



- 
- |     |                      |     |                  |
|-----|----------------------|-----|------------------|
| (A) | Rebound check sleeve | (B) | Intermediate pin |
| (C) | Striker housing      | (D) | Striker          |
| (E) | Copper cup           | (F) | Anvil            |
| (G) | Anvil housing        |     |                  |
- 

Figure 13.4.1.3: SAMPLE ASSEMBLY FOR LIQUIDS

## 13.4.2 *Test 3 (a) (ii): BAM Fallhammer*

### 13.4.2.1 *Introduction*

This test is used to measure the sensitiveness of solids and liquids to drop-weight impact and to determine if the substance is ~~too dangerous to transport unstable~~ in the form tested.

### 13.4.2.2 *Apparatus and materials*

13.4.2.2.1 The essential parts of the fallhammer are the cast steel block with base, the anvil, the column, the guides, the drop weights with release device and the impact device. A steel anvil is screwed onto the steel block and cast base. The support, into which is fixed the column (made from a seamless drawn steel tube), is bolted to the back of the steel block. The dimensions of the anvil, the steel block, the base and the column are given in Figure 13.4.2.1. The two guides which are fixed to the column by means of three cross-pieces are fitted with a toothed rack to limit the rebound of the drop weight and a movable graduated scale for adjusting the height of the fall. The drop weight release mechanism is adjustable between the guides and is clamped to them by the operation of a lever nut on two jaws. The apparatus is fixed onto a concrete block (600 × 600 mm) by means of four anchoring screws secured in the concrete, so that the base is in contact with the concrete over its whole area and the guides are exactly vertical. A wooden protective box with inner protective lining and which can be opened easily, surrounds the apparatus up to the level of the bottom cross-bar. An extraction system allows removal of any explosion gases or dust from the box.

13.4.2.2.2 The drop weights are shown in Figure 13.4.2.2. Each drop weight is provided with two locating grooves holding it between the guides as it drops, a suspension spigot, a removable cylindrical striking head and a rebound catch which are screwed on to the drop weight. The striking head is of hardened steel (HRC hardness of 60 to 63); its minimum diameter is 25 mm; it has a shoulder piece preventing it from being forced into the drop weight by the impact. Three drop weights are available with the following masses, 1.00 kg, 5.00 kg and 10.00 kg. The 1 kg-drop weight has a heavy steel centre fitted with the striking head. The 5 kg and 10 kg drop weights are of massive and compact steel, e.g. material specification at least St 37-1 in accordance with DIN 1700.

13.4.2.2.3 The sample of the substance under test is enclosed in an impact device consisting of two co-axial steel cylinders, one above the other in a hollow cylindrical steel guide ring. The cylinders are steel rollers from roller bearings with polished surfaces and rounded edges and a HRC hardness between 58 and 65. The dimensions of the cylinders and the ring are given in Figure 13.4.2.3. The impact device is placed on an intermediate anvil and centred by a locating ring with a ring of vent-holes to permit the escape of gases. The dimensions of the intermediate anvil are given in Figure 13.4.2.4 and those of the locating ring in Figure 13.4.2.3.

### 13.4.2.3 *Procedure*

13.4.2.3.1 For solid substances, other than paste-like or gel-types, the following points should be observed:

- (a) Substances in powdered form are sieved (sieve mesh 0.5 mm), all that passes through the sieve is used for the test<sup>1</sup>;
- (b) Substances which have been compressed, cast or otherwise consolidated are broken into small pieces and sieved; the fraction passing a 1.0 mm sieve and retained on a 0.5 mm sieve is used for the test<sup>1</sup>;
- (c) Substances which ~~are transported occur~~ only in the form of charges are tested in the form of discs (chips) with a volume of 40 mm<sup>3</sup> (approximately 4 mm diameter and 3 mm thickness).

The cylinders and the guide ring should be degreased with acetone before use. The cylinders and guide ring should only be used once.

<sup>1</sup> For substances which contain more than one constituent, the sieve fraction used for the test should be representative of the original sample.

13.4.2.3.2 For substances in powdered form, a sample is taken with a cylindrical measure of 40 mm<sup>3</sup> capacity (3.7 mm diameter × 3.7 mm). For paste-like or gel-type substances, a cylindrical tube of the same capacity is inserted into the substance and after levelling off the surplus, the sample is removed from the tube by means of a wooden rod. For liquid substances, a fine-drawn pipette of 40 mm<sup>3</sup> capacity is used. The substance is placed in the open impact device, which is already in the locating ring on the intermediate anvil, and for powders or paste-like or gel-type substances, the upper steel cylinder is gently pressed until it touches the sample without flattening it. Liquid samples are placed in the open impact device in such a way that it fills the groove between the lower steel cylinder and the guide ring. The upper steel cylinder is lowered, with the aid of the depth gauge, until it is 2 mm from the lower cylinder (see Figure 13.4.2.5) and held in place by a rubber "O" ring. In some cases, capillary action causes the sample to exude from around the top of the sleeve. In these cases, the assembly should be cleaned and the sample re-applied. The filled impact device is placed centrally on the main anvil, the protective wooden box is closed and the appropriate drop weight, suspended at the required height, is released. In the interpretation of the results of the trial, distinction is made between "no reaction", "decomposition" (without flame or explosion) recognisable by change of colour or odour and "explosion" (with weak to strong report or inflammation). In some cases it is advisable to perform trials with appropriate inert reference substances to allow a better judgement of whether or not an audible report has occurred.

13.4.2.3.3 The limiting impact energy, characterising the impact sensitiveness of a substance, is defined as that lowest impact energy at which the result "explosion" is obtained from at least one out of at least six trials. The impact energy used is calculated from the mass of the drop weight and the fall height (e.g. 1 kg × 0.5 m ≈ 5 J). The 1 kg drop weight is used at fall heights of 10, 20, 30, 40 and 50 cm (impact energy 1 to 5 J); the 5 kg drop weight for fall heights of 15, 20, 30, 40, 50 and 60 cm (impact energy 7.5 to 30 J) and the 10 kg drop weight for fall heights of 35, 40 and 50 cm (impact energy 35 to 50 J). The series of trials is started with a single trial at 10 J. If at this trial the result "explosion" is observed, the series is continued with trials at stepwise lower impact energies until the result "decomposition" or "no reaction" is observed. At this impact energy-level, the trial is repeated up to the total number of six if no "explosion" occurs; otherwise the impact energy is reduced in steps until the limiting impact energy is determined. If at the impact energy level of 10 J the result "decomposition" or "no reaction" (i.e. no explosion) was observed, the test series is continued by trials at stepwise increased impact energies until for the first time the result "explosion" is obtained. Now the impact energy is lowered again until the limiting impact energy is determined.

#### 13.4.2.4 *Test criteria and method of assessing results*

The test results are assessed on the basis of:

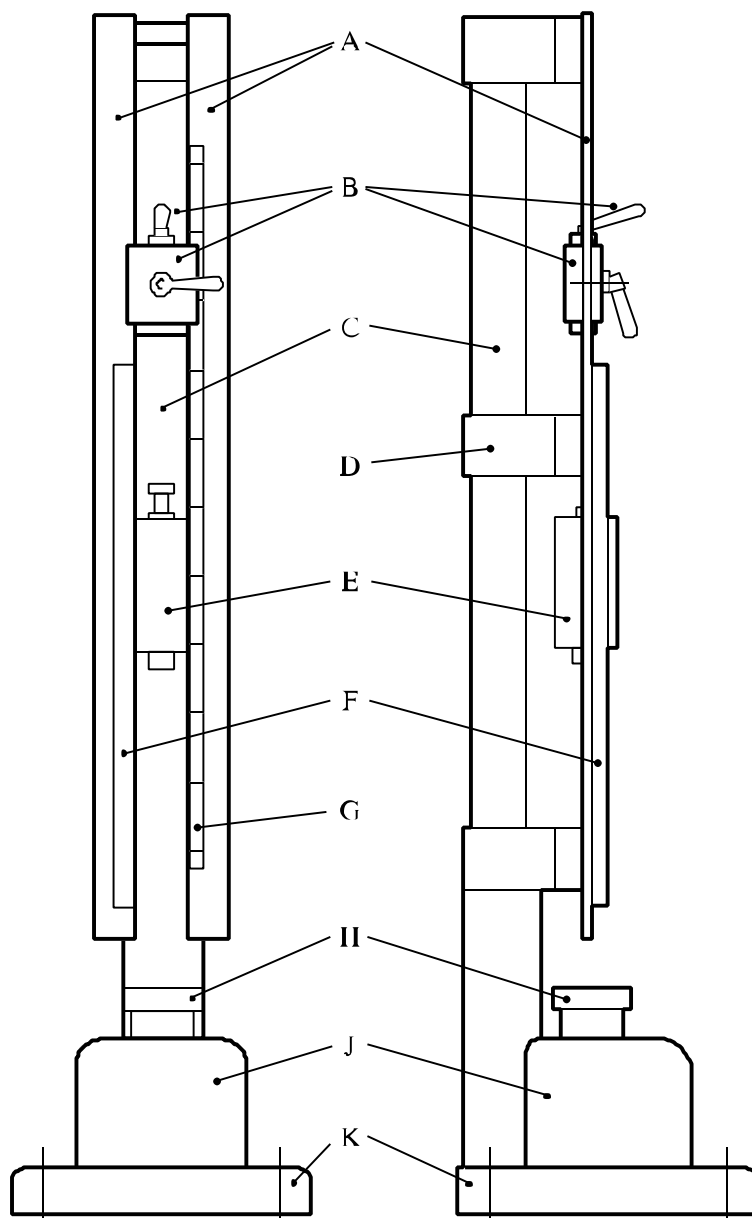
- (a) Whether an "explosion" occurs in any of up to six trials at a particular impact energy; and
- (b) The lowest impact energy at which at least one "explosion" occurs in six trials.

The test result is considered "+" if the lowest impact energy at which at least one "explosion" occurs in six trials is 2 J or less and the substance is considered ~~too dangerous for transport~~ unstable in the form in which it was tested. Otherwise, the result is considered "-".



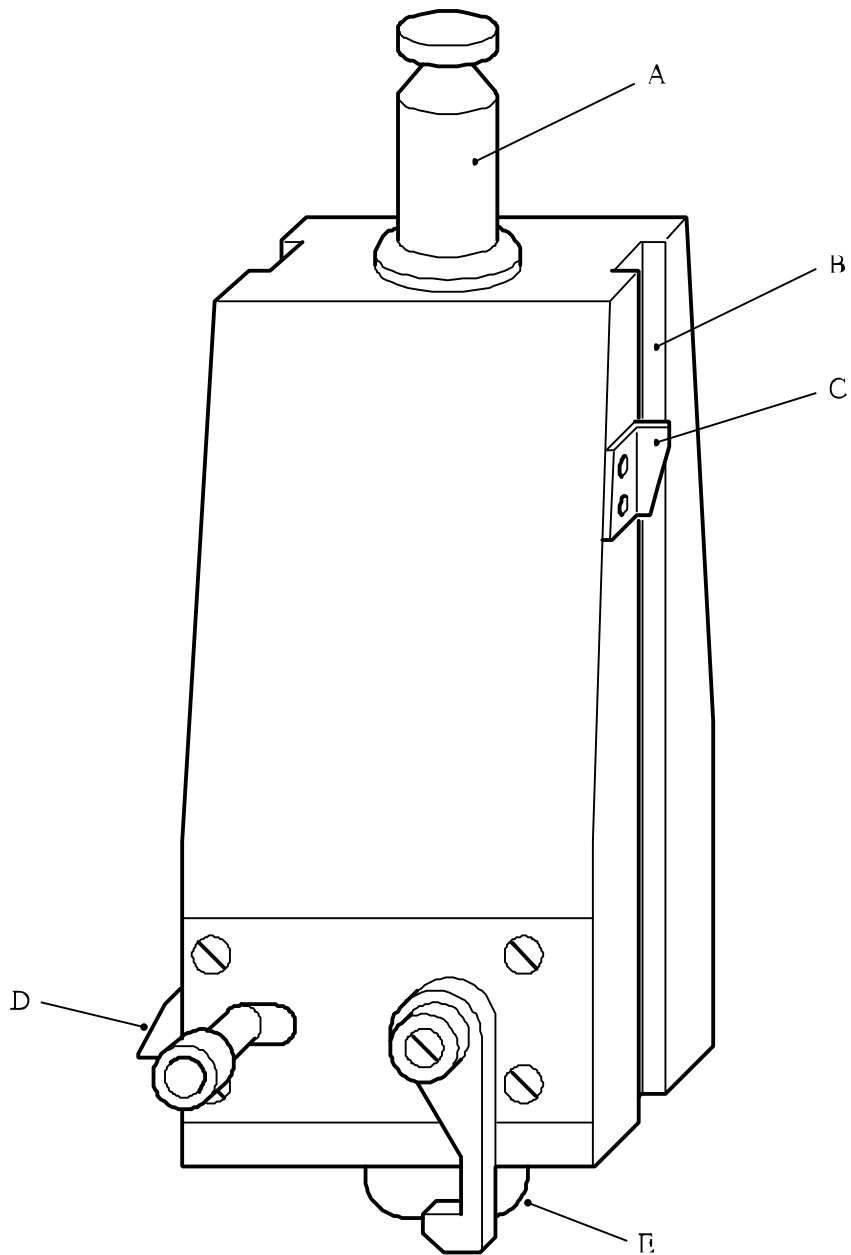
13.4.2.5 *Examples of results*

<b>Substance</b>	<b>Limiting impact energy (J)</b>	<b>Result</b>
Ethyl nitrate (liquid)	1	+
Hexal 70/30	10	-
Hydrazine perchlorate (dry)	2	+
Lead azide (dry)	2.5	-
Lead styphnate	5	-
Mannitol hexanitrate (dry)	1	+
Mercury fulminate (dry)	1	+
NG (liquid)	1	+
PETN (dry)	3	-
PETN/wax 95/5	3	-
PETN/Wax 93/7	5	-
PETN/wax 90/10	4	-
PETN/water 75/25	5	-
PETN/lactose 85/15	3	-
RDX/water 74/26	30	-
RDX (dry)	5	-
Tetryl (dry)	4	-



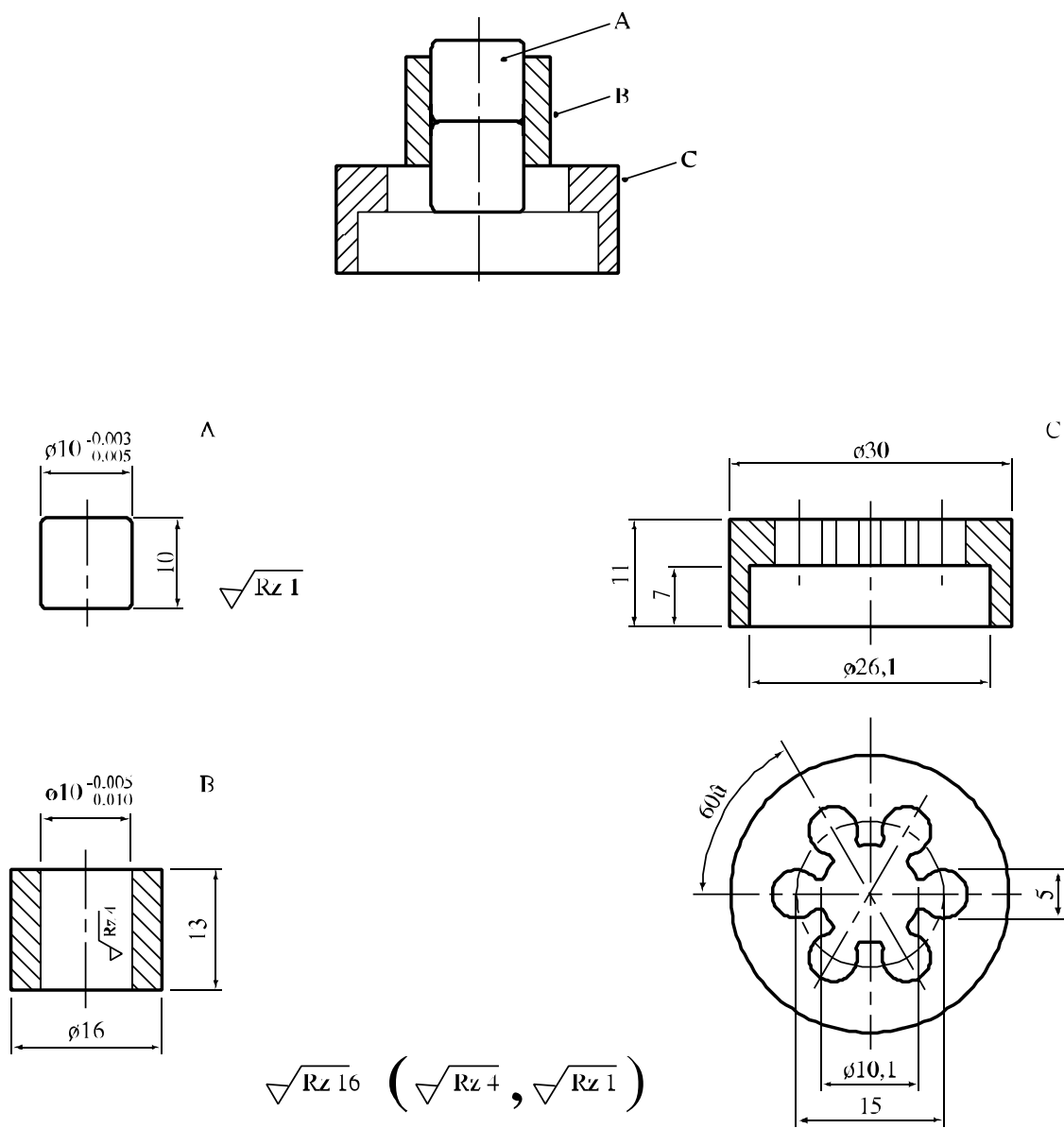
- 
- |     |                                |     |                               |
|-----|--------------------------------|-----|-------------------------------|
| (A) | Two guides                     | (B) | Holding and releasing device  |
| (C) | Column                         | (D) | Middle cross-piece            |
| (E) | Drop weight                    | (F) | Toothed rack                  |
| (G) | Graduated scale                | (H) | Anvil 100 mm diameter × 70 mm |
| (J) | Steel block 230 × 250 × 200 mm | (K) | Base 450 × 450 × 60 mm        |
- 

**Figure 13.4.2.1: BAM FALLHAMMER GENERAL VIEW, FRONT AND SIDE DIMENSIONS**



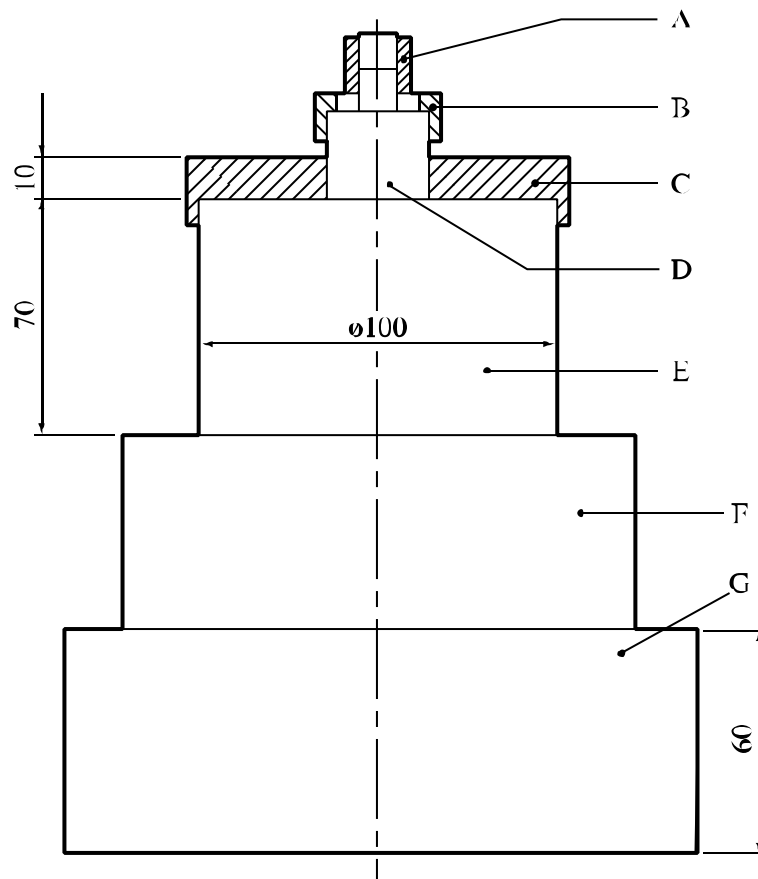
- 
- (A) Suspension spigot
  - (B) Positioning groove
  - (C) Height marker
  - (D) Rebound catch
  - (E) Cylindrical striking head
- 

**Figure 13.4.2.2: DROP WEIGHT**



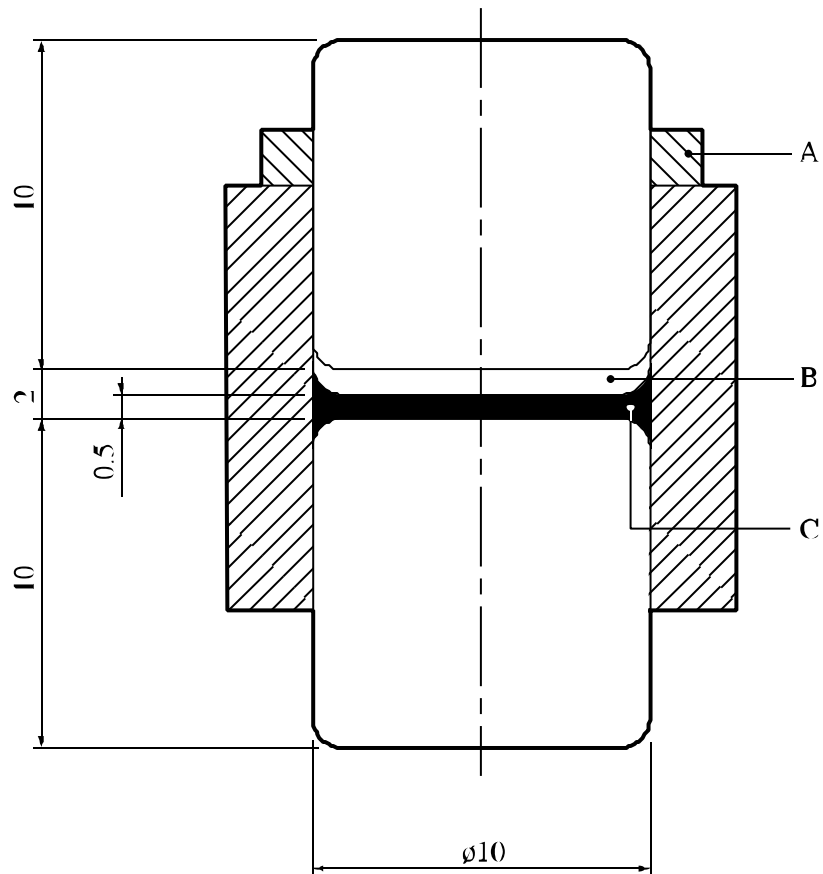
- (A) Steel cylinder(s)  
 (B) Guide collar  
 (C) Locating ring

Figure 13.4.2.3: IMPACT DEVICE FOR SUBSTANCES IN POWDERED, PASTE-LIKE OR GEL TYPE FORM AND LOCATING RING



- (A) Impact device
- (B) Locating ring
- (C) Locating plate
- (D) Intermediate anvil 26 mm diameter × 26 mm
- (E) Anvil 100 mm diameter × 70 mm
- (F) Steel block 230 × 250 × 200 mm
- (G) Base 450 × 450 × 60 mm

**Figure 13.4.2.4: LOWER PART**



- 
- (A) Rubber ring (can sometimes be omitted)  
(B) Space free from liquid  
(C) Liquid sample spread round circumference of steel cylinder
- 

**Figure 13.4.2.5: IMPACT DEVICE FOR LIQUIDS**

### 13.4.3 *Test 3 (a) (iii): Rotter test*

#### 13.4.3.1 *Introduction*

This test is used to measure the sensitiveness of the substance to drop-weight impact and to determine if the substance is ~~too dangerous to transport unstable~~ in the form tested. It is applicable to solid and liquid substances by using two different sample assemblies. The procedure can involve a direct comparison with a standard explosive, the median drop heights (50 per cent probability of ignition) being determined by the Bruceton method.

#### 13.4.3.2 *Apparatus and materials*

##### 13.4.3.2.1 Solids

The Rotter type impact machine (5 kg weight) and tools, are shown in outline in Figure 13.4.3.1 with an enlargement of the chamber in Figure 13.4.3.2. The hardened steel anvils, brass caps, measuring device (0.03 cm<sup>3</sup> volume), tamping device and gas measuring burette (50 cm<sup>3</sup>) are manufactured to standard drawings. The standard explosive is RDX, recrystallized from cyclohexanone and dried according to a standard procedure.

##### 13.4.3.2.2 Liquids

The equipment used for testing liquids is the Rotter type impact machine but with a different type of impact assembly (Figure 13.4.3.3) and drift (Figure 13.4.3.4), and without the burette. A 2 kg weight is employed. The various items shown in figures 13.4.3.2 to 13.4.3.4 are manufactured to standard drawings, as is a hardened steel disc for calibration of the cup and plunger assemblies.

#### 13.4.3.3 *Procedure*

##### 13.4.3.3.1 Solids

For solids, other than pastes or gels, the following points should be observed:

- If necessary, substances in coarse powdered form are crushed to pass through a 850 µm sieve; and
- Cast substances are either crushed and passed through a 850 µm sieve or 0.03 cm<sup>3</sup> discs are cut from the solid with nominal dimensions of 4 mm diameter and 2 mm thickness.

13.4.3.3.2 Powdered substances are measured into the caps with the measuring device and low bulk density substances are tamped with the tamping device. The loaded cap is placed upon the anvil in such a way as to avoid inversion of the cap before the substance makes contact with the anvil tip. The cap is then rotated to spread the explosive evenly, the chamber is closed, the striker is adjusted so that it is in contact with the cap and the chamber placed in position in the machine. The logarithms of the standard drop heights are arranged on a linear scale. The initial heights for starting the Bruceton (see Appendix 2) runs for the sample under test and the standard are determined by interpolation between the nearest "go" (ignition) and "no go" (non ignition) until these occur at adjacent levels. In a normal test, 50-shot Bruceton runs are performed. If the Sample Comparison Test (SCT) procedure (see Appendix 2) is used, caps of the standard and the sample under test are fired alternately, a separate Bruceton run being operated for each. When testing any explosive substance, a "go" is said to have occurred if 1 cm<sup>3</sup> or more of gaseous products are recorded on the manometer or if so indicated by non-standard transient movement of the manometer fluid which is confirmed by the presence of smoke on opening the anvil housing. For some pyrotechnics a lesser effect, e.g. colour change, is accepted as evidence of a "go". After testing each cap, the anvil and the interior of the chamber must be thoroughly cleaned and dried; the anvil is examined and changed if visibly damaged. Dropping the weight from heights much in excess of 200 cm can itself damage the anvil. Unless obtained from the SCT procedure, data for the standard is obtained from 50-shot running mean determinations.

##### 13.4.3.3.3 Liquids

Individual cups and plungers for use with liquids are paired off before testing begins. The calibration disc is inserted into each cup in turn, its plunger added and the assembly located in the impact chamber. After the ball-bearing has been placed on top of the plunger, the upper part of the housing is fitted to the cap retainer and locked in position. The cap is then inserted and screwed down until the ball seating contacts the ball. This initial setting is read off

a circular scale of 100 divisions on top of the upper part of the housing, and the reading is specific to the individual combination of cup and plunger used. Each division on the circular scale corresponds to a vertical displacement of 0.02 mm. For the test itself, an O-ring is placed in the cup. 0.025 cm<sup>3</sup> of the liquid under test is metered into the cavity, a suitable dispenser being a 0.5 cm<sup>3</sup> gas-tight syringe used in conjunction with a ratchet and a finely tipped plastic nozzle. A stainless steel disc is then dropped on to the O-ring, this seals off 0.025 cm<sup>3</sup> of air. The plunger is then located on top. The assembly is placed in the impact chamber, the ball-bearing on top of the plunger, and the upper part of the housing fitted and locked into position. The cap is then screwed down by hand until it contacts the ball (Figure 13.4.3.3). A standard pre-compression is applied to the sample chamber by screwing down the cap to the initial calibration position for the particular cup and plunger used, and for a further standard number of divisions on the circular scale. The housing is placed under the drop weight machine with the spherically recessed drift (Figure 13.4.3.4) resting on top of the ball-bearing. The testing procedure is similar to that for solids, the same Bruceton scale being used. A "go" is said to have occurred if a "bang" louder than that from a drop of equal height on to an inert liquid is heard, or if there is residual pressure in the sample chamber, or if on dismantling decomposition products are seen or smelt. Following "no goes" unchanged liquid remains in the sample chamber. After testing, the cup and plunger are thoroughly cleaned and if either shows signs of damage (usually pitting) it is replaced, when recalibration using the calibration disc is required. In any case, the O-ring and stainless steel disc are replaced by new components after each test.

#### 13.4.3.4 *Test criteria and method of assessing results*

##### 13.4.3.4.1 Solids

The test results are assessed on the basis of:

- (a) Whether a "go" is observed in a trial;
- (b) Determination of the median drop height for the RDX reference standard and the sample by the Bruceton method (see Appendix 2); and
- (c) Comparison of the running mean median drop height of the standard ( $H_1$ ) with the median drop height of the sample ( $H_2$ ) using the equation:

$$\text{Figure of Insensitiveness (F of I)} = 80 \times H_2/H_1$$

(if  $H_2 \geq 200$  cm then the F of I is given as  $> 200$ )

The test result is considered "+" if the F of I is less than or equal to 80 and the substance is considered ~~too dangerous for transport-unstable~~ in the form in which it was tested. The test result is considered "-" if the F of I is greater than 80. If the F of I obtained for the substance under test is less than 80, a direct comparison with the standard RDX may be made by using the Sample Comparison Test (SCT - see Appendix 2) procedure with 100 shots on each substance. If there is 95% or greater confidence that the substance under test is not more sensitive than RDX, the substance under test is not ~~too dangerous for transport-unstable~~ in the form tested.

##### 13.4.3.4.2 Liquids

The test results are assessed on the basis of:

- Whether a "go" is observed in a test; and
- Determination of the median drop height for the sample by the Bruceton method.

The median drop height for liquids is calculated as for solids, and the result quoted directly. For samples which do not give "goes" at drop heights of approximately 125 cm, the median height is quoted as "> 125 cm". The test result is considered "+" and the liquid ~~too dangerous for transport-unstable~~ in the form tested if it is more sensitive in this test than iso-propyl nitrate. This is normally determined from the median height value, but if the median height obtained for the substance under test is less than that quoted for iso-propyl nitrate, 14.0 cm, a direct comparison with iso-propyl nitrate may be made by using the SCT procedure with 100 shots on each substance. If there is 95% or greater confidence that the substance under test is not more sensitive than iso-propyl nitrate, the substance under test is not ~~too dangerous for transport-unstable~~ in the form tested. The result is considered "-" if the median height is greater than or equal to that of iso-propyl nitrate.



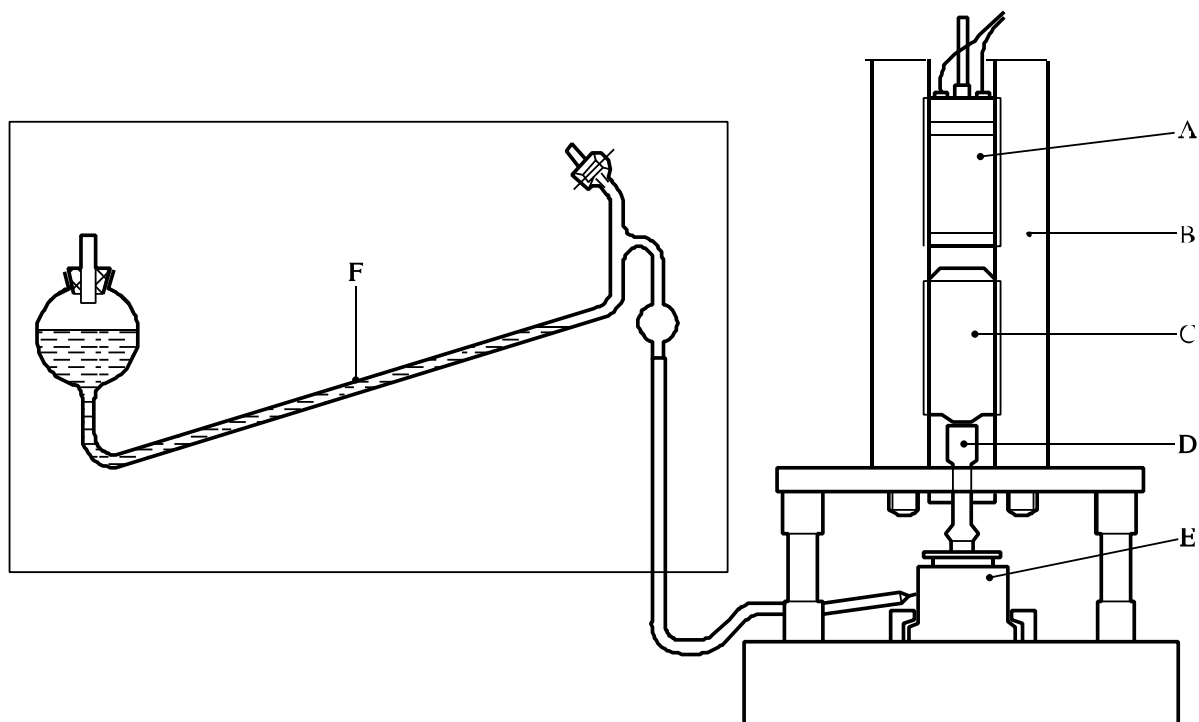
13.4.3.5 *Examples of results*

13.4.3.5.1 Solids

Substance	F of I	Result
Blasting Gelatine-geophex	15	+
Blasting Gelatine-Submarine	15	+
Cordite	20	+
1,3-Dinitrobenzene	>200	-
Guanidine nitrate	>200	-
HMX	60	+
Lead azide (service)	30	+
PETN	50	+
PETN/wax 90/10	90	-
RDX	80	+
Tetryl	90	-
TNT	140	-

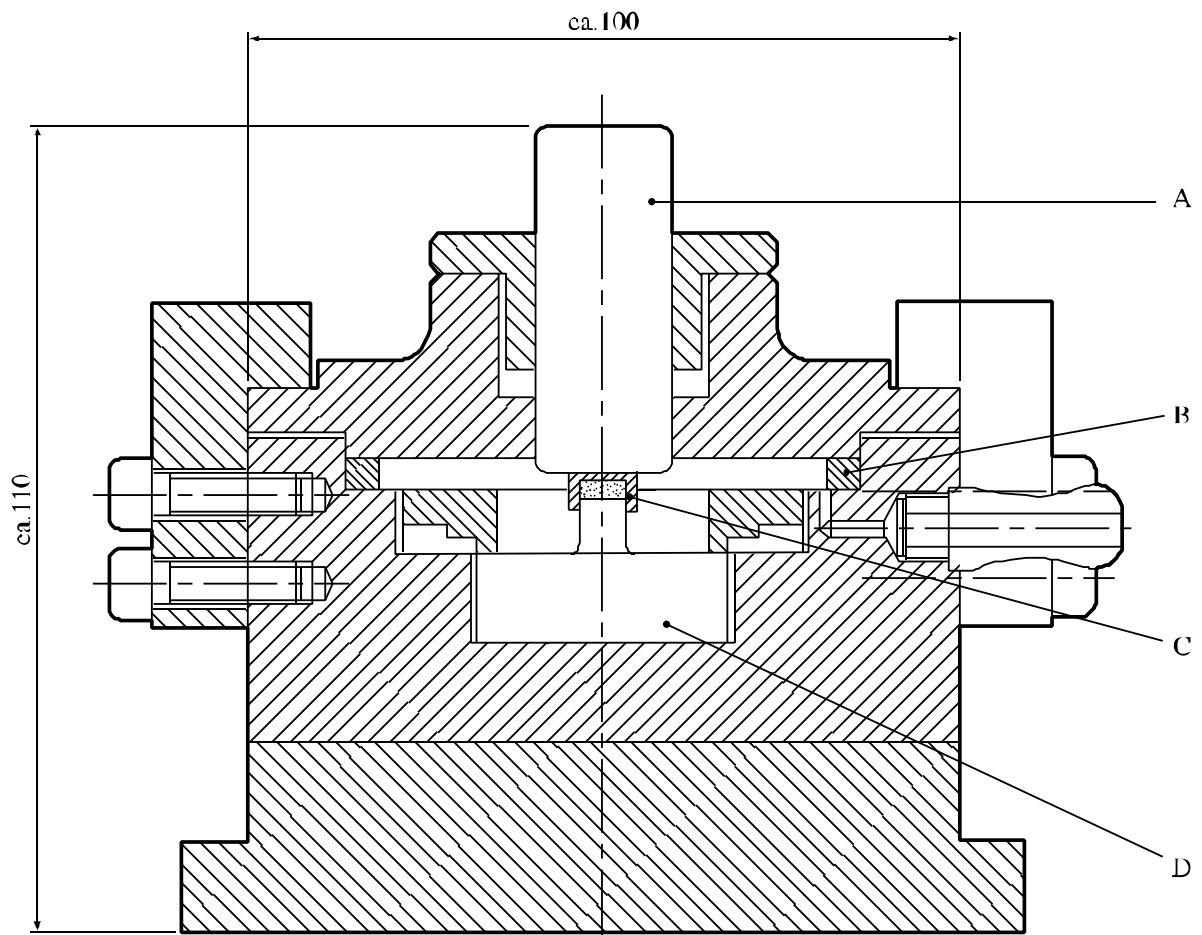
13.4.3.5.2 Liquids

Substance	Median height(cm)	Result
Diethylene glycol dinitrate	12	+
Diethylene glycol mononitrate	46	-
1,1-Dinitroethane	21	-
Dinitroethylbenzene	87	-
Glyceryl trinitrate (nitroglycerine, NG)	5	+
Isopropyl nitrate	14	+
Nitrobenzene	>125	-
Nitromethane	62	-
Triethylene glycol dinitrate	10	+
Triethylene glycol mononitrate	64	-



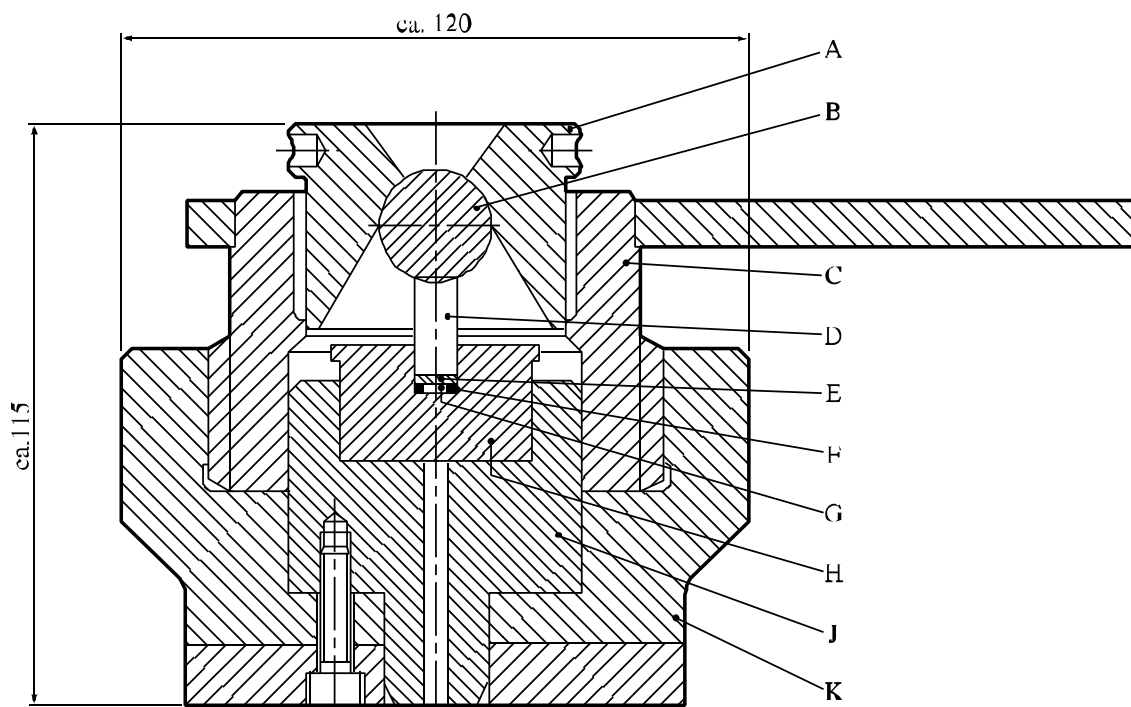
- 
- (A) Magnet  
(B) Tubular guides  
(C) Weight  
(D) Drift  
(E) Chamber  
(F) Manometer containing dyed paraffin oil
- 

**Figure 13.4.3.1: ROTTER TEST**



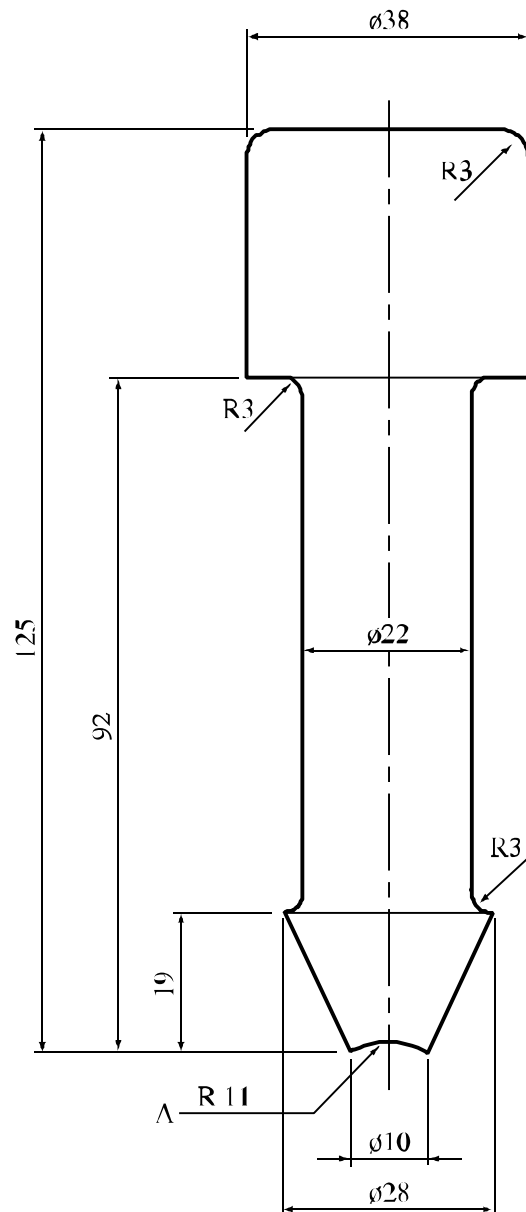
- (A) Striker
- (B) Sealing ring
- (C) Cap
- (D) Anvil

Figure 13.4.3.2: EXPLOSION CHAMBER



- 
- (A) Cap
  - (B) 7/8 inch (22.2 mm) ball bearing
  - (C) Upper part of housing
  - (D) Plunger made of hardened tool steel
  - (E) Stainless steel disc
  - (F) Rubber O-ring
  - (G) Test sample
  - (H) Cup made of hardened tool steel
  - (J) Impact chamber
  - (K) Cap retainer
- 

**Figure 13.4.3.3: CUP AND PLUNGER ASSEMBLY AND HOUSING FOR LIQUIDS**



(A) Spherical

Figure 13.4.3.4: LIQUID IMPACT TEST INTERMEDIATE DRIFT

### 13.4.4 Test 3 (a) (iv): 30 kg Fallhammer test

#### 13.4.4.1 Introduction

This test is used to measure the sensitiveness of solids and liquids to drop-weight impact and to determine if the substance is ~~too dangerous to transport unstable~~ in the form tested.

#### 13.4.4.2 Apparatus and materials

The test apparatus and materials are shown in detail in figures 13.4.4.1 and 13.4.4.2. The steel sample tray (wall thickness ca. 0.4 mm) is 8 mm deep, 50 mm wide and 150 mm long.

#### 13.4.4.3 Procedure

The sample tray is uniformly filled with the substance to a depth of 8 mm. The tray is placed on the anvil in such a way that the hammer falls onto a point 25 mm from one end, on the axis of the tray (see Figure 13.4.4.1). The fallhammer is released from a height of 4.00 m to 0.25 m in steps of 0.25 m. Propagation is considered to have occurred if explosive effects, primarily deformation of the tray walls, are observed at least 100 mm from the impacted point in the sample. Three trials are performed at each height. The limiting drop height is the highest height at which no propagation occurs in three trials. If there is no propagation using a drop height of 4.00 m, the limiting height is recorded as "≥ 4.00 m".

#### 13.4.4.4 Test criteria and method of assessing results

The test results are assessed on the basis of:

- (a) Whether there is propagation of reaction; and
- (b) The limiting drop height.

The test result is considered "+" if a limiting drop height of less than 0.75 m is observed and the substance is considered ~~too dangerous for transport unstable~~ in the form in which it was tested. The test result is considered "-" if a limiting drop height greater than or equal to 0.75 m is observed.

#### 13.4.4.5 Examples of results

Substances	Limiting height (m)	Result
Ammonium perchlorate	≥ 4.00	-
HMX 0 - 100 µm (70% min ≤40 µm) <sup>a</sup>	0.50	+
HMX 80 - 800 µm (50% min ≥315 µm) <sup>a, b</sup>	1.75	-
Hydrazine nitrate, melted <sup>c</sup>	0.25	+
Mining explosive <sup>d</sup>	≥ 4.00	-
Nitroglycerine	0.50	+
Nitroguanidine	≥ 4.00	-
PETN fine (40% min ≤ 40 µm)	0.50	+
RDX 0 - 100 µm (55% min ≤ 40 µm) <sup>a</sup>	1.00	-
RDX mean size 125 - 200 µm	2.00	-
TNT flakes <sup>e</sup>	≥ 4.00	-
TNT cast	≥ 4.00	-

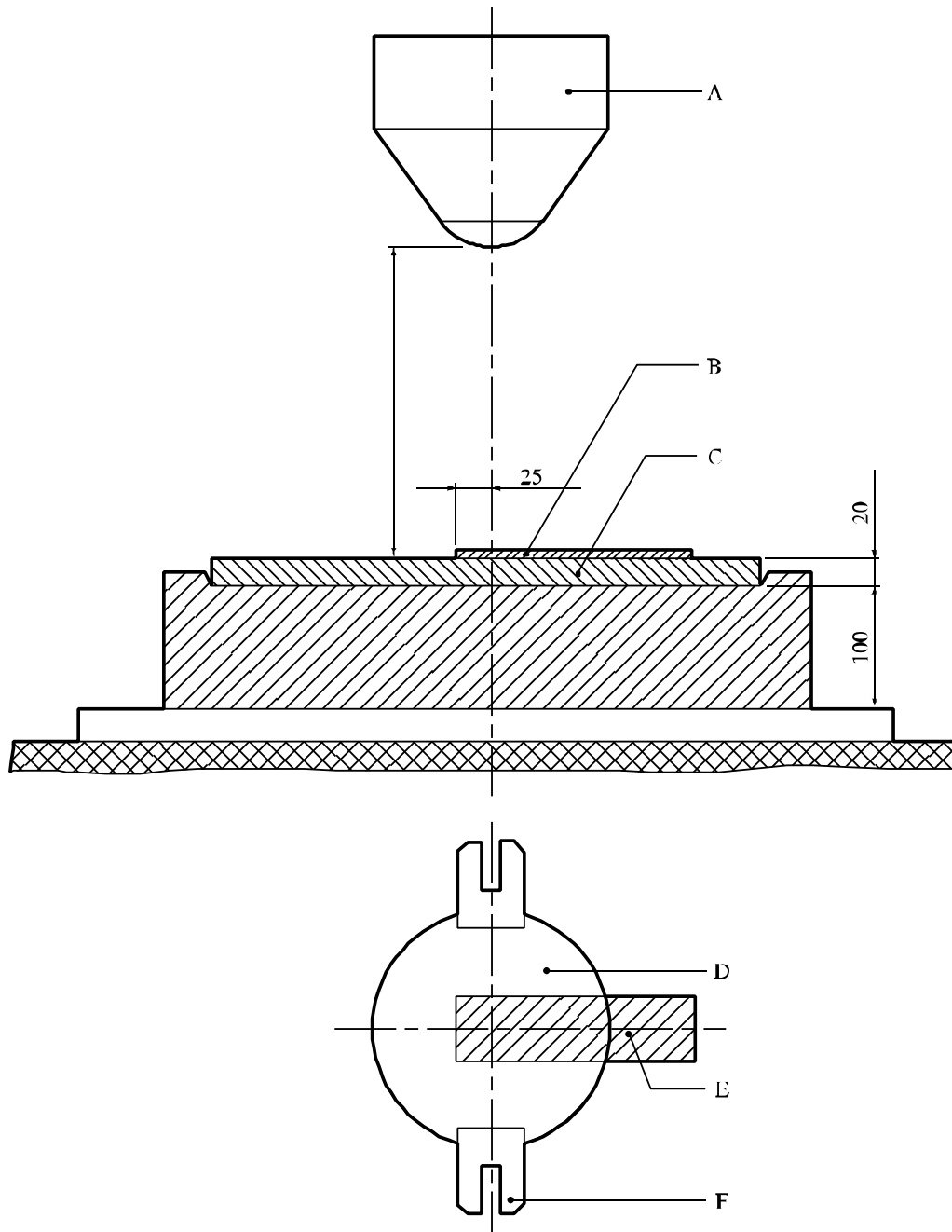
<sup>a</sup> Recrystallized from cyclohexanone<sup>b</sup>

<sup>c</sup> 60-80 °C

<sup>e</sup> Melting point ≥ 80.1 °C

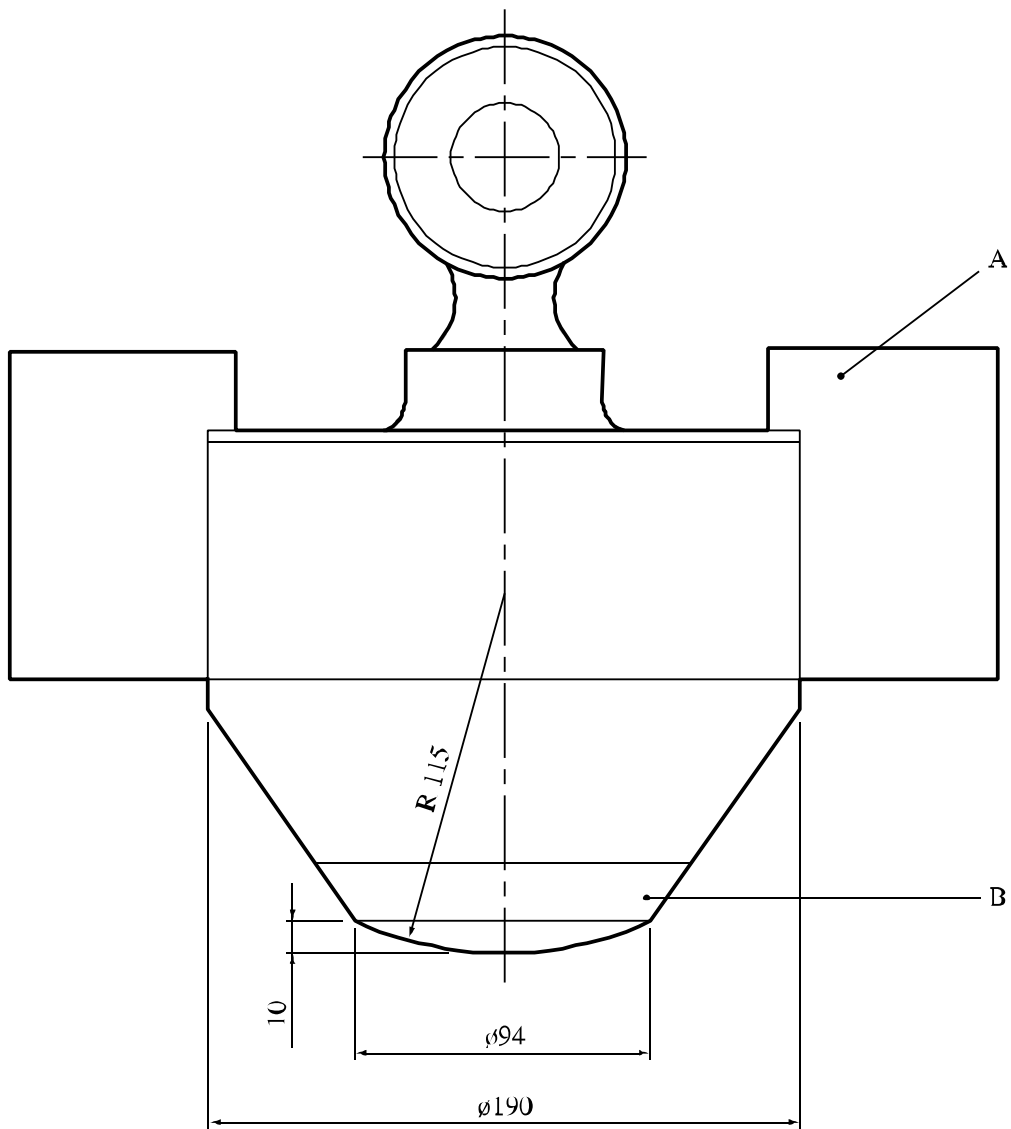
RDX content : max. 3%

<sup>d</sup> AN based, with Pentolite 11.5% and Al 8.5%



- |     |                 |     |              |
|-----|-----------------|-----|--------------|
| (A) | 30 Kg weight    | (B) | Sample       |
| (C) | removable anvil | (D) | 30 Kg weight |
| (E) | Sample          | (F) | Guide - lug  |

Figure 13.4.4.1: 30 kg FALLHAMMER TEST



- 
- (A) Guide - lug  
(B) Removable nose
- 

Figure 13.4.4.2: DROP WEIGHT



**13.4.5** *Test 3 (a) (v): Modified type 12 impact tool*13.4.5.1 *Introduction*

This test is used to measure the sensitiveness of substances to drop-weight impact and to determine if the substance is ~~too dangerous to transport unstable~~ in the form tested. It is applicable to solid and liquid substances by using two different sample assemblies.

13.4.5.2 *Apparatus and materials*

The following apparatus and materials are required:

- (a) A drop mechanism capable of dropping, via three guides, a mass of 1.0, 1.5, 1.8, 2.0, 2.5 or 5.0 kg through a vertical distance of up to 3.0 m onto an intermediate mass resting on a sample placed on an anvil. The drop and intermediate masses are used in the following combinations:
  - (i) 1.5 kg intermediate mass with a 1.0, 1.5, 1.8 or 2.0 kg drop mass;
  - (ii) 2.0 kg intermediate mass with a 1.0 or 2.0 kg drop mass; and
  - (iii) 2.5 kg intermediate mass with 2.5 or 5.0 kg drop mass;
- (b) A target assembly (modified Type 12 tool) consisting of an anvil (impact surface 32 mm diameter) and a guide for the intermediate mass;
- (c) Garnet paper cut into  $25 \pm 2$  mm squares;
- (d) A balance with an accuracy of  $\pm 1$  mg;
- (e) Brass caps with 10.0 mm diameter, 4.8 mm height and 0.5 mm wall thickness;
- (f) Stainless steel discs 8.4 mm diameter and 0.4 mm thick;
- (g) Neoprene O-rings 8.4 mm diameter and 1.3 mm thick;
- (h) 50  $\mu$ l syringe;
- (i) Micro-spatula.

13.4.5.3 *Procedure*13.4.5.3.1 *Solids*

The intermediate mass is raised.  $30 \pm 5$  mg of the test substance is placed in a loose pile centrally on the anvil (for less sensitive substances,  $30 \pm 5$  mg of the test substance is placed on a square of garnet paper and the garnet paper with the test substance is placed on the anvil). The intermediate mass is then carefully lowered onto the substance on the anvil. The drop mass is raised to 36.0 cm (the height in the middle of the logarithmic series of drop heights) and released to drop onto the intermediate mass. The intermediate mass is raised. The trial is assessed as positive if the sample reacts with an audible report, if there is production of smoke or odour, or there is visual evidence of an ignition. Note the type of reaction that occurs. The surfaces are cleaned with a cloth. The initial drop height for application of the Bruceton method (see Appendix 2) is determined by interpolation between the nearest drop heights giving positive and negative results until these occur on adjacent levels. 25 trials are then performed selecting the heights using the Bruceton method with a base 10 logarithmic interval of 0.093 giving the following series of drop heights: 6.5, 8, 10, 12, 15, 19, 24, 29, 36, 45, 55, 69, 85, 105, 131, 162 and 200 cm. The median height calculated from the results using the procedure given in Appendix 2. The combination of a 1.8 kg drop mass and a 1.5 kg intermediate mass, without the use of garnet paper, has been found to be optimal for determining whether substances are more or less sensitive than RDX.

13.4.5.3.2 Liquids

An O-ring is inserted into a cap and tamped down to the bottom. 25 µl<sup>2</sup> of the test substance is placed in the cap using a syringe. A stainless steel disc is placed on the O-ring. The intermediate mass is raised and the cap assembly is placed on the anvil. The intermediate mass is lowered carefully so that it fits into the cap and compresses the O-ring. The drop mass is raised and released to drop onto the intermediate mass. The intermediate mass is raised. The trial is assessed as positive if the sample reacts with an audible report, if there is production of smoke or odour, or if there is visual evidence of an ignition. Note the type of reaction that occurred. The initial height is selected using the procedure given in 13.4.5.3.1. 25 trials are performed and the median height calculated using the procedure given in Appendix 2. The combination of a 1.0 kg drop mass and a 1.5 kg intermediate mass (designed for testing liquids) has been found to be optimal for determining whether substances are more or less sensitive than isopropyl nitrate.

13.4.5.4 *Test criteria and method of assessing results*

13.4.5.4.1 The test results are assessed on the basis of:

- (a) Whether a positive reaction is obtained in a trial; and
- (b) Determination of the median drop height (H<sub>50</sub>) for the sample by the Bruceton method.

Details of the statistics used to determine H<sub>50</sub> and the standard deviation can be found in Appendix 2.

13.4.5.4.2 Solids

The test result is considered "+" if the median drop height (H<sub>50</sub>) is less than or equal to that of dry RDX and the substance is considered ~~too dangerous for transport unstable~~ in the form in which it was tested. The test result is considered "-" if the medium drop height (H<sub>50</sub>) is greater than that of dry RDX.

13.4.5.4.3 Liquids

The test result is considered "+" if the median drop height (H<sub>50</sub>) is less than that of isopropyl nitrate and the substance is considered ~~too dangerous for transport unstable~~ in the form in which it was tested. The test result is considered "-" if the medium drop height (H<sub>50</sub>) is equal to or greater than that of isopropyl nitrate.

13.4.5.5 *Examples of results*

13.4.5.5.1 Solids

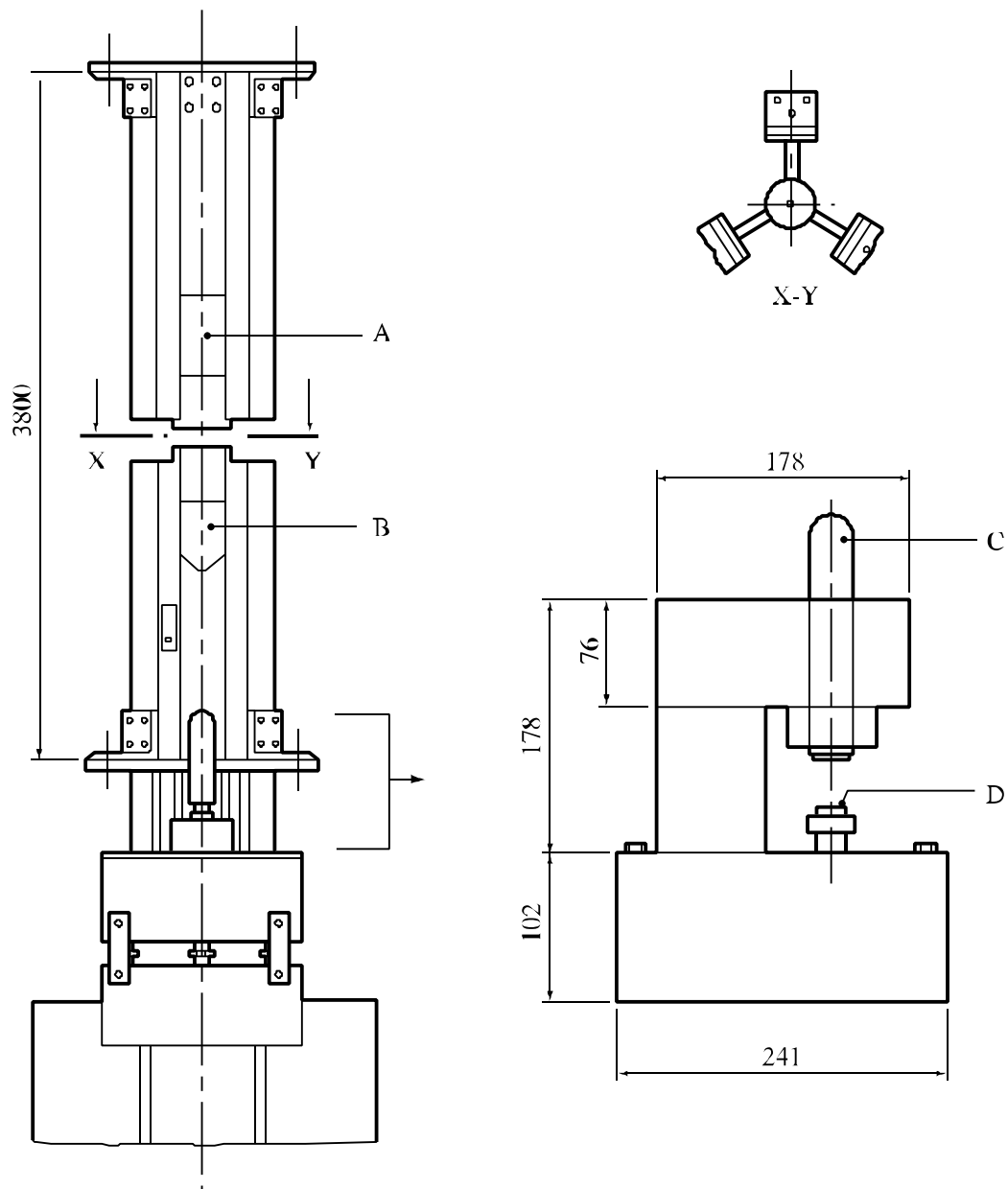
Substances	Median height (cm)	Result
<b>1.8 kg drop mass, 1.5 kg intermediate mass, no garnet paper</b>		
PETN (superfine)	15	+
RDX Grade 1	38	+
RDX/water (75/25)	> 200	-
Tetryl	> 200	-
TNT (200 mesh)	> 200	-

<sup>2</sup> *The relationship between the sample volume and the sensitiveness of the liquid is a function specific to the liquid. The volume selected in this procedure is suitable for determining relative sensitiveness. A determination of the relationship between the sensitiveness and the sample volume should be carried out when more detailed information is required about the substance.*

Substances	Median height (cm)	Result
<b>2.5 kg drop mass, 2.5 kg intermediate mass, with garnet paper</b>		
PETN (superfine)	5	+
RDX (Cal 767)	12	+
Tetryl	13	-
TNT (200 mesh)	25	-

13.4.5.5.2 Liquids

Substances	Median height (cm)	Result
<b>1.0 kg drop mass, 2.0 kg intermediate mass</b>		
Isopropyl nitrate (99%, boiling point. 101-102 °C)	18	-
Nitromethane	26	-
TEGDN	14	+
TMETN	10	+
TEGDN/TMETN (50/50)	13	+



- 
- (A) Electromagnet
  - (B) Drop mass (e.g. 2.5 kg)
  - (C) Intermediate mass (e.g. 2.5 kg , diameter 32 mm)
  - (D) Anvil (impact surface 32 mm diameter)
- 

**Figure 13.4.5.1: MODIFIED TYPE 12 IMPACT TOOL (Full, top and expanded side view)**

**13.4.6**      *Test 3 (a) (vi): Impact sensitivity test*13.4.6.1      *Introduction*

This test is used to measure the sensitiveness of the substance to drop-weight impact and to determine if the substance is ~~too dangerous to transport unstable~~ in the form tested. It is applicable to solid and liquid substances by using two different sample assemblies.

13.4.6.2      *Apparatus and materials*

13.4.6.2.1      Figure 13.4.6.1 shows a diagram of the impact apparatus. The main components of the apparatus are:

- (a)    An anvil made of seamless steel;
- (b)    Vertical parallel guide columns for a falling weight;
- (c)    A steel weight (10 kg ) with a limit stop - the weight impact head is made of hardened steel (Rockwell Chardness 60-63);
- (d)    A catching and dropping device;
- (e)    A rack which prevents the weight from repeatedly falling and impacting on the sample on the anvil; and
- (f)    A measuring rule with 1 mm scale divisions.

13.4.6.2.2      The test sample is placed into the roller assembly 2 (solids) or 3 (liquids). Dimensions and requirements for these roller assemblies are shown in figures 13.4.6.2 and 13.4.6.3. The following additional equipment is also required:

- (a)    A laboratory balance with a weighing error of no more than 0.005 g;
- (b)    A hydraulic press which provides a compression pressure of 290 MPa; and
- (c)    A standard explosive, tetryl (recrystallized from acetone) with crystal sizes 0.200-0.270 mm.

13.4.6.3      *Procedure*13.4.6.3.1      *Solids*

13.4.6.3.1.1      As a rule substances are tested in the form in which they are received. Wetted substances should be tested with the minimum quantity of wetting agent required ~~for transport~~. Depending on their physical form, the substances should then be subjected to the following procedures:

- (a)    Granulated, flaky, pressed, cast and similar substances are milled and sieved; particles should pass through a sieve with 0.9-1.0 mm mesh sizes;
- (b)    Elastic substances are cut with a sharpened knife on a wooden surface into pieces not more than 1 mm in size. Elastic substances samples are not sieved; and
- (c)    Powdered and plastic explosives samples are not ground and sieved.

Roller assemblies for solid samples are degreased with acetone or ethyl alcohol. Prepared test assemblies should have 0.02-0.03 mm difference between the diameters of the sleeves and the rollers. The components may be re-used if they remain within specification.

13.4.6.3.1.2      To determine the lower sensitivity limit of the explosive under test, a sample with mass of  $100 \pm 5$  mg is placed on the roller surface in the opened roller of assembly 2. The sleeve should be aligned with the direction of the groove downwards. The second roller is placed on the explosive sample and the upper roller is used to smooth it out by

pressing and rotating. The assembly containing the explosive is placed on a hydraulic press, where it is compressed to a pressure of 290 MPa. For plastic, elastic and pasty explosives, the pressure is preselected so that the explosive is not pressed out beyond the faces of the rollers. Wetted explosives are not compressed. The sleeve with the rollers and the explosive is then turned over in a tray and placed against the rollers as far as they will go. This ensures that the explosive is in contact with the sleeve groove. The assembly containing the explosive is placed on the anvil of the impact apparatus. The weight (10 kg) falls and impacts the sample.

13.4.6.3.1.3 The lower limit of explosive impact sensitivity is defined as the maximum drop height of the 10 kg steel weight which does not give positive results in 25 trials. The drop height is selected from the following range: 50, 70, 100, 120, 150, 200, 250, 300, 400, 500 mm. Tests are carried out beginning with 150 mm drop height. A sound effect, flash or burn traces on the rollers and sleeve are taken as a positive reaction. Discolouration of the sample is not considered as a sign of explosion. If positive results are obtained at this height the test is repeated with the next lower drop height. Conversely, when negative results are obtained, the next higher drop height is used. Thus the maximum drop height for a 10 kg mass is obtained when no positive reaction occurs in 25 tests. If, at the 50 mm drop height, positive results are obtained in 25 tests, it is established that the lower sensitivity limit of explosive tested in roller assembly 2 is < 50 mm. When no positive reaction occurs in 25 tests for the 500 mm drop height, then the lower impact sensitivity limit for the explosive tested in roller assembly 2 is expressed as 500 mm or more.

#### 13.4.6.3.2 Liquids

13.4.6.3.2.1 Roller assemblies 3 are degreased with acetone or ethyl alcohol. Usually 35-40 roller assemblies are prepared. The roller assemblies should have a 0.02-0.03 mm difference between the diameters of sleeves and rollers.

13.4.6.3.2.2 To determine the lower sensitivity limit, the liquid substance is placed in the cap with a dropping tube or pipette. The cap is positioned in the centre of the lower roller and is completely filled with the liquid substance. The second roller is carefully placed on the cap containing the liquid substance, the roller assembly is placed on the impact apparatus anvil and the steel weight is dropped. The result is noted.

13.4.6.3.2.3 The lower limit of an explosive impact sensitivity is defined as the maximum drop height of the 10 kg steel weight which does not give positive results in 25 trials. The drop height is selected from the following range: 50, 70, 100, 120, 150, 200, 250, 300, 400, 500 mm. Tests are carried out beginning with a 150 mm height. If positive results are obtained at this height, the test is repeated with the next lower drop height. Conversely, when negative results are obtained, the next higher drop height is used. Thus the maximum drop height for 10 kg mass is obtained when no positive reaction occurs in 25 tests. If, at the 50 mm drop height, one or more positive results are obtained in 25 tests then it is established that the lower sensitivity limit of explosive tested in roller assembly 3 is < 50 mm. If no positive reaction occurs in 25 tests for the 500 mm drop height, the lower impact sensitivity limit for the explosive tested in roller assembly 3 is expressed as 500 mm or more.

#### 13.4.6.4 *Test criteria and method of assessing results*

##### 13.4.6.4.1 Solids

The test results are assessed on the basis of:

- (a) Whether one or more positive results are obtained in 25 trials at a particular height; and
- (b) The lowest height at which a positive result is obtained.

The test result is considered "+" if the lowest height at which a positive result is obtained with assembly 2 is less than 100 mm and the substance is considered ~~too dangerous for transport unstable~~ in the form in which it was tested. The test result is considered "-" if the lowest impact height for a positive result with assembly 2 is equal to or greater than 100 mm.

##### 13.4.6.4.2 Liquids

The test results are assessed on the basis of:

- (a) Whether one or more positive results are obtained in 25 trials at a particular height; and
- (b) The lowest height at which a positive result is obtained.

The test result is considered "+" if the lowest height at which a positive result is obtained with assembly 3 is less than 100 mm and the substance is considered ~~too dangerous for transport~~ unstable in the form in which it was tested. The test result is considered "-" if the lowest impact height for a positive result with assembly 3 is equal to or greater than 100 mm.

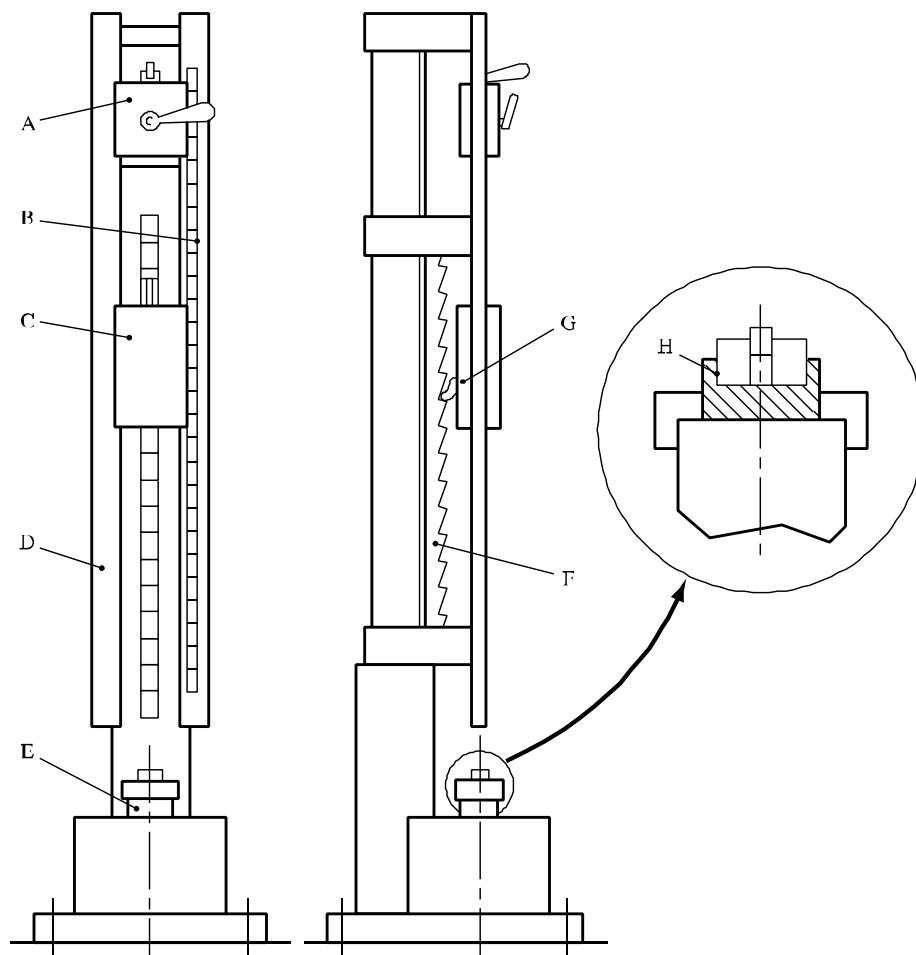
13.4.6.5 *Examples of results*

13.4.6.5.1 Solids

Substances	Lower limit in assembly 2 (mm)	Result
Ammonal (80.5% ammonium nitrate, 15% trotyl, 4.5% aluminium)	150	-
Ammonal, splitting (66% ammonium nitrate, 24% hexogen, 5% aluminium)	120	-
Ammonite 6ZhV (79% ammonium nitrate, 21% Trotyl)	200	-
Ammonite T-19 (61% ammonium nitrate, 19% Trotyl, 20% sodium chloride)	300	-
Cyclotrimethylenetrinitramine (dry)	70	+
Cyclotrimethylenetrinitramine / wax 95/5	120	-
Cyclotrimethylenetrinitramine / water 85/15	150	-
Granulite AS-8 (91.8% ammonium nitrate, 4.2% machine oil, 4% aluminium)	>500	-
Pentaerythritol tetranitrate (dry)	50	+
Pentaerythritol tetranitrate / paraffin 95/5	70	+
Pentaerythritol tetranitrate / paraffin 90/10	100	-
Pentaerythritol tetranitrate / water 75/25	100	-
Picric acid	>500	-
Tetryl	100	-
Trinitrotoluene	>500	-

13.4.6.5.2 Liquids

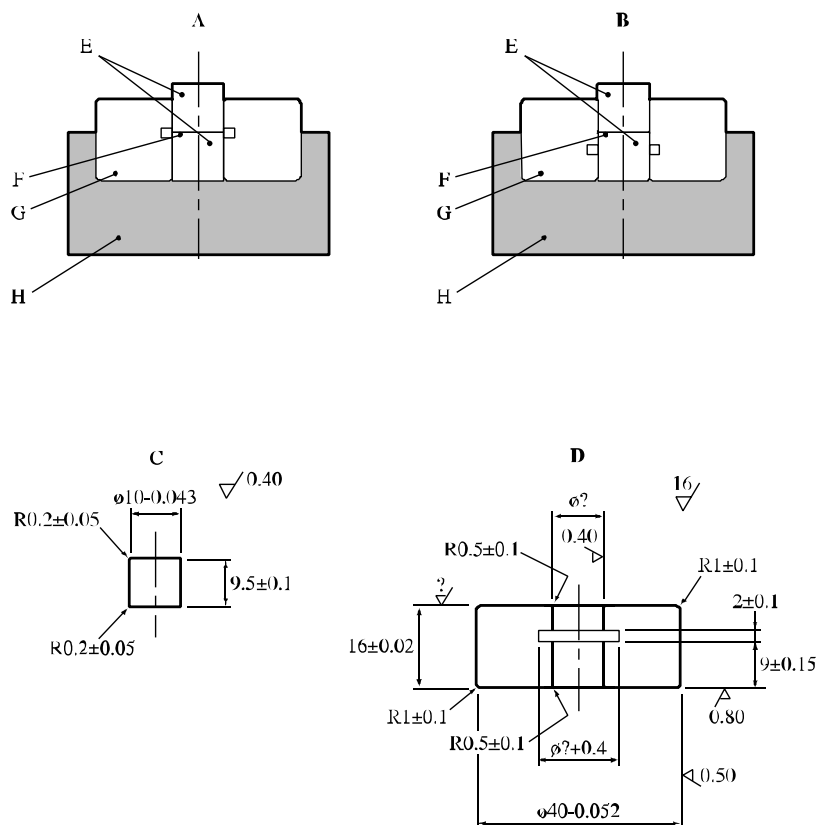
Substances	Lower limit in assembly 2 (mm)	Result
Di-(2,2-dinitro-2-fluoro-ethyl)formal/methylene chloride 65/35	400	-
Isopropyl nitrate	>500	-
Nitroglycerine	<50	+
Nitromethane	>500	-



- 
- |     |                              |     |                                   |
|-----|------------------------------|-----|-----------------------------------|
| (A) | Catching and dropping device | (B) | Graduated scale                   |
| (C) | Drop weight                  | (D) | Guide column                      |
| (E) | Anvil                        | (F) | Rack                              |
| (G) | Ratchet to catch rebound     | (H) | Magnified view of roller assembly |
- 

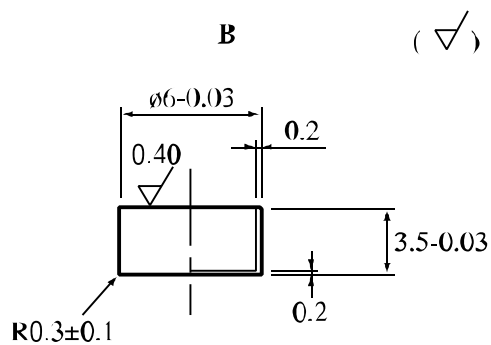
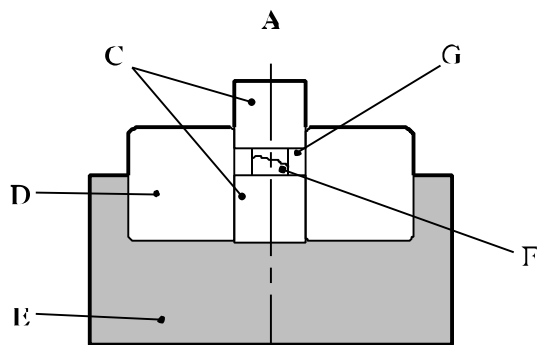
**Figure 13.4.6.1: IMPACT APPARATUS**





- |   |  |
|---|--|
| (A) Sleeve position "groove facing upwards"     | (B) Sleeve position "groove facing downwards"  |
| (C) Roller of ball bearing steel to HRC 63 - 66 | (D) Sleeve of tool carbon steel to HRC 57 - 61 |
| (E) Rollers                                     | (F) Sample                                     |
| (G) Sleeve                                      | (H) Tray                                       |

Figure 13.4.6.2: ROLLER ASSEMBLY 2



- 
- (A) Roller assembly 3  
(B) 3 micron nickel plated copper (M2) cap  
(C) Rollers  
(D) Sleeve  
(E) Tray  
(F) Sample  
(G) Cap
- 

Figure 13.4.6.3: ROLLER ASSEMBLY 3

**13.4.7 Test 3 (a) (vii): Modified Bureau of Mines impact machine test**

## 13.4.7.1 Introduction

This test is used to measure the sensitiveness of the substance to drop-mass impact and to determine if the substance is ~~too dangerous to transport unstable~~ in the form tested. The test substance is subjected to a vertical impact force through an intermediate hammer via a drop mass. It is applicable to solid, semisolid, liquid, and powder substances.

## 13.4.7.2 Apparatus and materials

13.4.7.2.1 The general design of the MBOM impact test apparatus is given in Figure 13.4.7.1. The following components are required:

A mechanism containing a drop mass of 2.0 kg, two drop mass guide rails, a drop mass holding, lifting, and dropping mechanism, and a 1.0 kg intermediate hammer containing a 1.27 cm diameter steel insert with a surface roughness of 1.3 – 1.8 µm that is resting on a sample placed on a steel anvil (impact surface 3.8 cm diameter) with a surface roughness of 1.3 – 1.8 µm. Details of the target area are given in Figure 13.4.7.2.

## 13.4.7.3 Procedure

## 13.4.7.3.1 Solid sample placement

As a rule substances are tested in the form in which they are received. Wetted substances should be tested with the minimum quantity of wetting agent required ~~for transport~~. Depending on the physical form, the substances should then be subjected to the following procedures:

- (a) Powders are to be tested on the anvil in a monolayer; i.e., the thickness of the granular material. Place enough granules on the anvil to cover an area in excess of the 1.3 cm<sup>2</sup> area of the insert.
- (b) Solid propellants are tested in the form of thin, uniform slices. The slices are usually square, having a minimum edge length of 1.6 cm and a thickness of 0.08 ± 0.01 cm. This thickness is easily obtainable with the use of a microtome cutting tool.

The intermediate hammer is raised. The test substance is placed centrally on the anvil. The intermediate hammer is then carefully lowered onto the substance on the anvil.

## 13.4.7.3.2 Liquids and semisolids sample placement

Depending on the physical form, the substances should then be subjected to the following procedures:

- (a) Liquids are tested with a controlled thickness and a fixed gap of 0.05 cm above the liquid level using a spring between the hammer collar and the guide collar (adjustable tension). The thickness of the liquid sample is controlled by putting a piece of 0.015 cm thick tape (compatible with the substance) with a 1.6 cm diameter hole in it on the anvil. The intermediate hammer is raised. The hole in the tape is centrally positioned on the anvil such that the intermediate hammer insert does not touch the tape. A 0.05 cm feeler gauge is used to set the proper gap above the liquid. The tape hole is filled with the liquid substance and levelled-off using a straight-edge ensuring that no air gaps are present in the sample. The intermediate hammer is then carefully lowered to 0.05 cm above the substance on the anvil.
- (b) Semisolids (slurries, gels, etc.) are prepared and tested in much the same way as liquid samples; however, the sample thickness is governed by the largest particle size. If the largest particle size is greater than the 0.015 cm thickness then a monolayer sample is spread on the anvil in a monolayer; i.e., the thickness of the granular material. If the cohesive properties of the semisolid are not practical for a 0.015 cm thickness, then the minimum attainable thickness is used. Place enough granules on the anvil to cover an area in excess of the 1.3 cm<sup>2</sup> area of the intermediate hammer insert.

## 13.4.7.3.3 Machine operation

The drop mass is raised to the desired height (17 cm for solids and semisolids and 11 cm for liquids) and released to drop onto the intermediate hammer. Observations are made on whether a “reaction” occurs as evidenced by audible report or production of smoke, fire, charring or visible light as observed by human senses. The type of reaction that occurs is documented. The surfaces are cleaned with a cloth or light abrasive pad to remove any residual material

from the anvil or intermediate hammer insert. The anvil and intermediate hammer insert are inspected for scratches, scoring, divots, or other damage which may affect the surface roughness. If damaged these items should be replaced before use on the next trial. Six trials are performed for each test sample.

#### 13.4.7.4 *Maintenance and calibration*

Moving parts should be inspected to ensure that they are freely moving and that friction between them is minimal. The distance between the drop mass and the intermediate hammer that is resting on the anvil should be verified. The contact area between the intermediate hammer insert and anvil should be uniform. The test machine should be periodically cleaned and calibrated according to a schedule based on the amount of usage. At a minimum, the machine should be calibrated on an annual basis.

#### 13.4.7.5 *Test criteria and method of assessing results*

##### 13.4.7.5.1 Solids

The test result is considered “+” if a reaction (see 13.4.7.3.3) is observed in at least 1 out of 6 trials at a drop height of 17 cm and the substance is considered ~~too dangerous for transport~~ unstable in the form in which it was tested. Otherwise, the result is considered “-”. Borderline cases may be resolved using the Bruce-ton method (see Appendix 2).

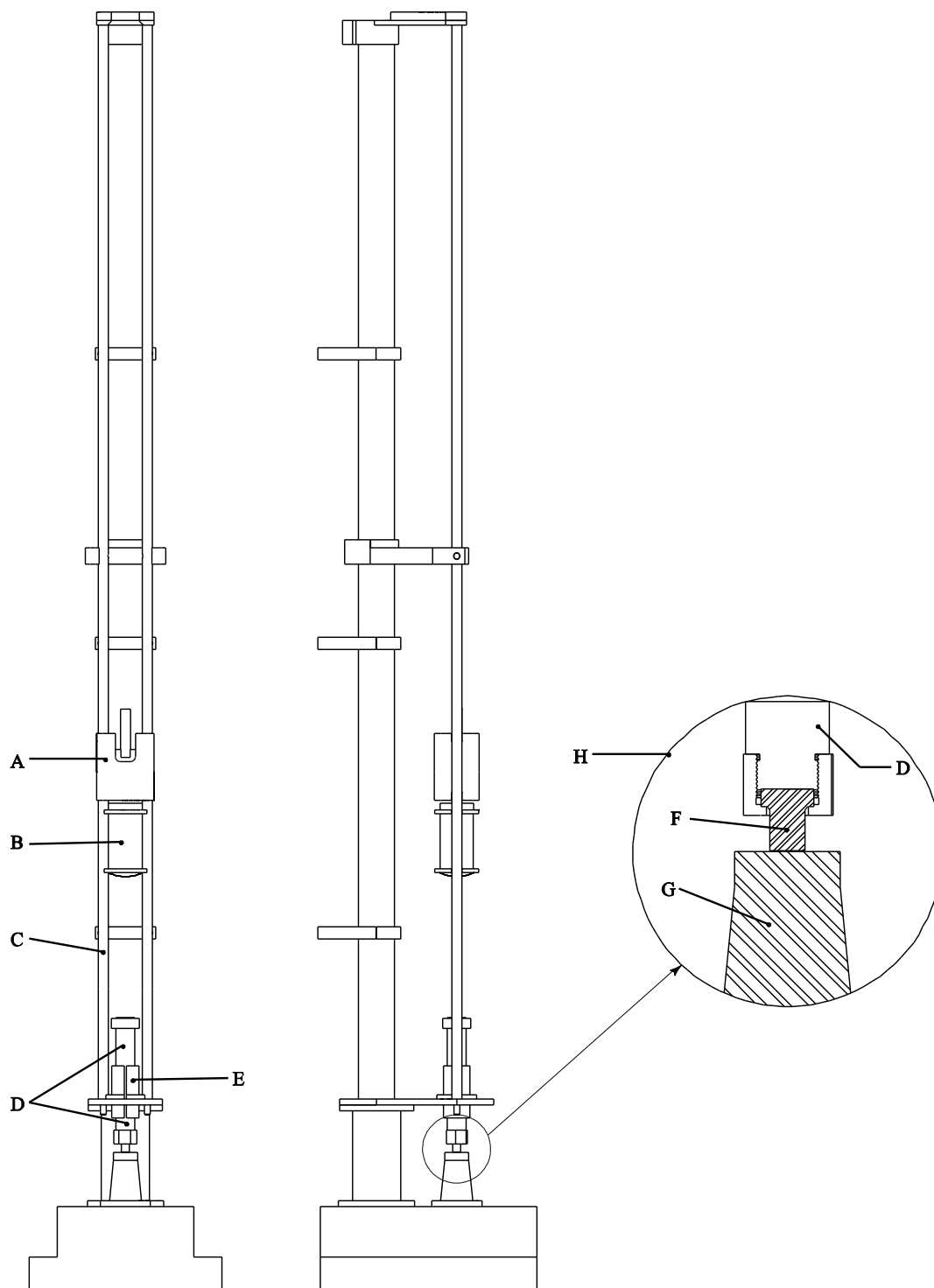
##### 13.4.7.5.2 Liquids

The test result is considered “+” if a reaction (see 13.4.7.3.3) is observed in at least 1 out of 6 trials at a drop height of 11 cm and the substance is considered ~~too dangerous for transport~~ unstable in the form in which it was tested. Otherwise, the result is considered “-”. Borderline cases may be resolved using the Bruce-ton method (see Appendix 2).

#### 13.4.7.6 *Examples of results*

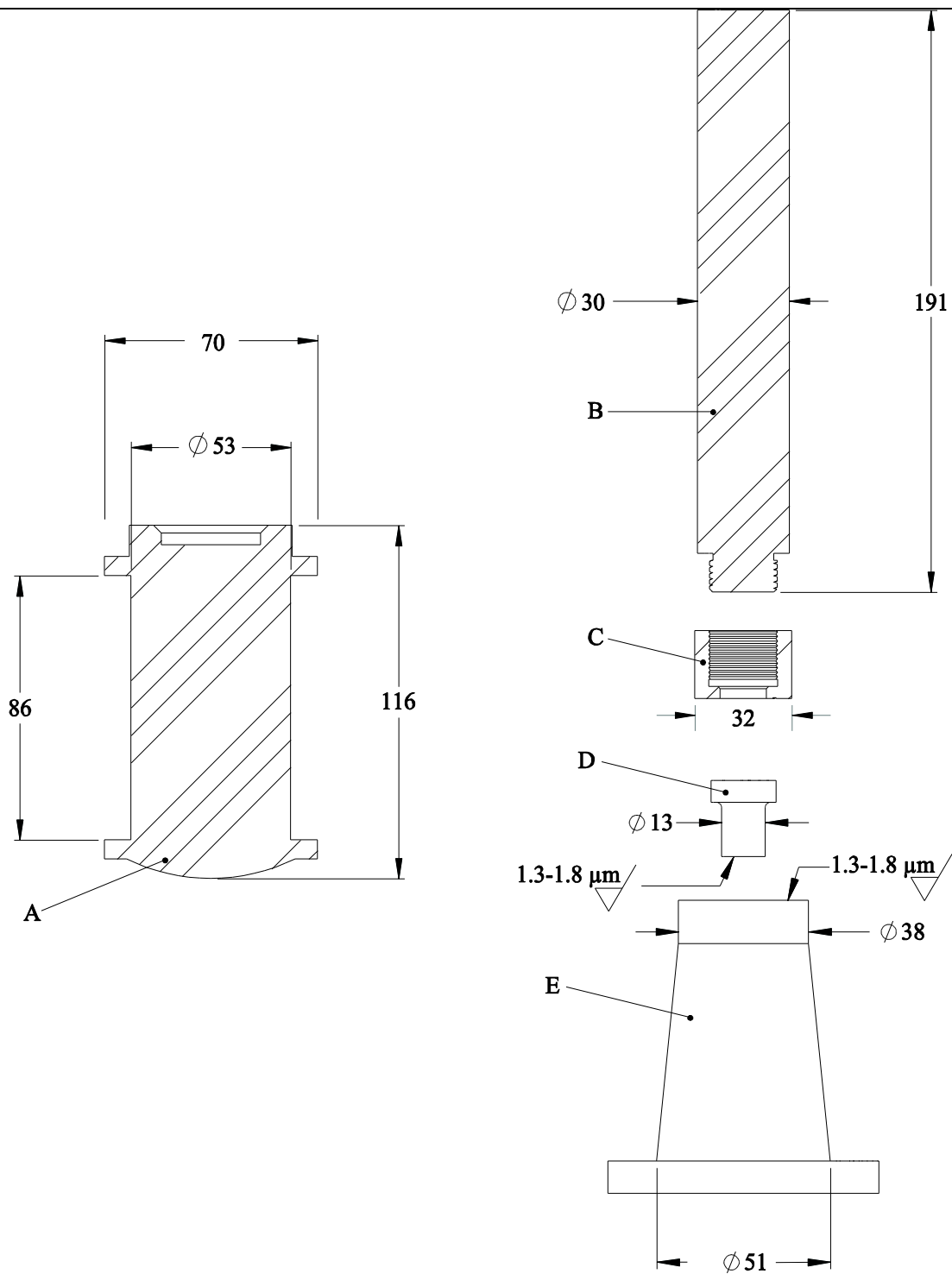
<b>Substances<sup>1</sup></b>	<b>Result</b>
RDX (dry)	+
PBXN-8	-
Nitrocellulose/DNT (90/10)	-
PETN (dry)	+
Nitroglycerin	+

<sup>1</sup> *Data acquired at relative humidity of 10-30% and temperature of 16-24 °C*



(A)	Drop mass lifting, holding, and dropping device	(B)	Drop mass
(C)	Drop mass guide rails	(D)	Intermediate hammer
(E)	Intermediate hammer guide	(F)	Intermediate hammer insert
(G)	Anvil	(H)	Magnified view of target area

Figure 13.4.7.1: MBOM Impact machine



- 
- (A) Drop mass
  - (B) Intermediate hammer
  - (C) Intermediate hammer insert retaining nut
  - (D) Intermediate hammer insert
  - (E) Anvil
- 

Figure 13.4.7.2: MBOM Impact machine drop mass and target area detail

## 13.5 Series 3 type (b) test prescriptions

### 13.5.1 Test 3 (b) (i): BAM friction apparatus

#### 13.5.1.1 Introduction

This test is used to measure the sensitiveness of the substance to frictional stimuli and to determine if the substance is ~~too dangerous to transport unstable~~ in the form tested.

#### 13.5.1.2 Apparatus and materials

13.5.1.2.1 The friction apparatus (see Figure 13.5.1.1) consists of a cast steel base, on which is mounted the friction device proper. This comprises a fixed porcelain peg and a moving porcelain plate (see paragraph 13.5.1.2.2). The porcelain plate is held in a carriage which runs in two guides. The carriage is connected to an electric motor via a connecting rod, an eccentric cam and suitable gearing such that the porcelain plate is moved, once only, backwards and forwards beneath the porcelain peg a distance of 10 mm. The loading device pivots on an axis so that the porcelain peg can be changed; it is extended by a loading arm which is fitted with 6 notches for the attachment of a weight. Zero load is obtained by adjusting a counterweight. When the loading device is lowered onto the porcelain plate, the longitudinal axis of the porcelain peg is perpendicular to the plate. There are different weights of masses up to 10 kg. The loading arm is fitted with 6 notches of distances of 11 cm, 16 cm, 21 cm, 26 cm, 31 cm and 36 cm from the axis of the porcelain peg. A weight is hung into a notch on the loading arm by means of a ring and hook. The use of different weights in different notches results in loads on the peg of 5 - 10 - 20 - 40 - 60 - 80 - 120 - 160 - 240 - 360 N. If necessary, intermediate loads may be used.

13.5.1.2.2 The flat porcelain plates are made from technical white porcelain and, before being fired, their two rubbing surfaces (roughness 9 - 32 microns) are thoroughly roughened by being rubbed with a sponge. The sponge marks are clearly visible. The cylindrical porcelain pegs are also in technical white porcelain and their roughened ends are rounded. The dimensions of plate and peg are given in Figure 13.5.1.2.

#### 13.5.1.3 Procedure

13.5.1.3.1 Normally the substances are tested as received. Wetted substances should be tested with the minimum content of wetting agent provided ~~for transport~~. In addition, for solids substances other than paste-like or gel-types, the following points should be observed:

- (a) Substances in powdered form are sieved (sieve mesh 0.5 mm); everything that passes through the sieve is used for the test<sup>3</sup>;
- (b) Substances which have been compressed, cast or otherwise consolidated are broken into small pieces and sieved; all that passes through a 0.5 mm mesh sieve is used for the test<sup>3</sup>;
- (c) Substances which ~~are transported~~occur only in the form of charges are tested in the form of discs or chips of 10 mm<sup>3</sup> (minimum diameter: 4 mm).

Each part of the surface of the plate and peg must only be used once; the two ends of each peg will serve for two trials and the two friction surfaces of a plate will each serve for three trials.

13.5.1.3.2 A porcelain plate is fixed on the carriage of the friction apparatus so that the grooves of the sponge-marks on it run transversely to the direction of movement. The quantity to be tested, about 10 mm<sup>3</sup>, is taken from substances in powdered form by means of a cylindrical measure (2.3 mm diameter × 2.4 mm deep); for paste-like or gel-type substances, a rectangular 0.5 mm thick gauge with a 2 × 10 mm window is used; the window is filled with the substance to be tested on the plate, and the gauge is removed carefully. The firmly clamped porcelain peg is placed onto the sample as in Figure 13.5.1.2; the loading arm is loaded with the required weights and the switch is operated. Care

<sup>3</sup> For substances which contain more than one constituent, the sieved sample should be representative of the original substance.

must be taken to ensure that the peg rests on the sample, and that there is enough of the substance to come under the peg when the porcelain plate moves in front of the peg.

13.5.1.3.3 The series of trials is started with a single trial at a load of 360 N. The results of each trial are interpreted in terms of "no reaction", "decomposition" (change of colour or odour) or "explosion" (report, crackling, sparking or flame). If in the first trial the result "explosion" is observed, the series is continued with trials at stepwise lower loads until the result "decomposition" or "no reaction" is observed. At this friction load level the trial is repeated up to the total number of six if no "explosion" occurs; otherwise the friction load is reduced in steps until the lowest load is determined at which no "explosion" occurs in six trials. If in the first trial at 360 N the result "decomposition" or "no reaction" occurs, up to five further trials are performed. If in all six trials at the highest load, the result "decomposition" or "no reaction" occurs, the substance is deemed to be insensitive to friction. If an "explosion" is obtained, the load is reduced as above. The limiting load is defined as the lowest load at which the result "explosion" is obtained from at least one out of at least six trials.

13.5.1.3.4 Test criteria and method of assessing results

The test results are assessed on the basis of:

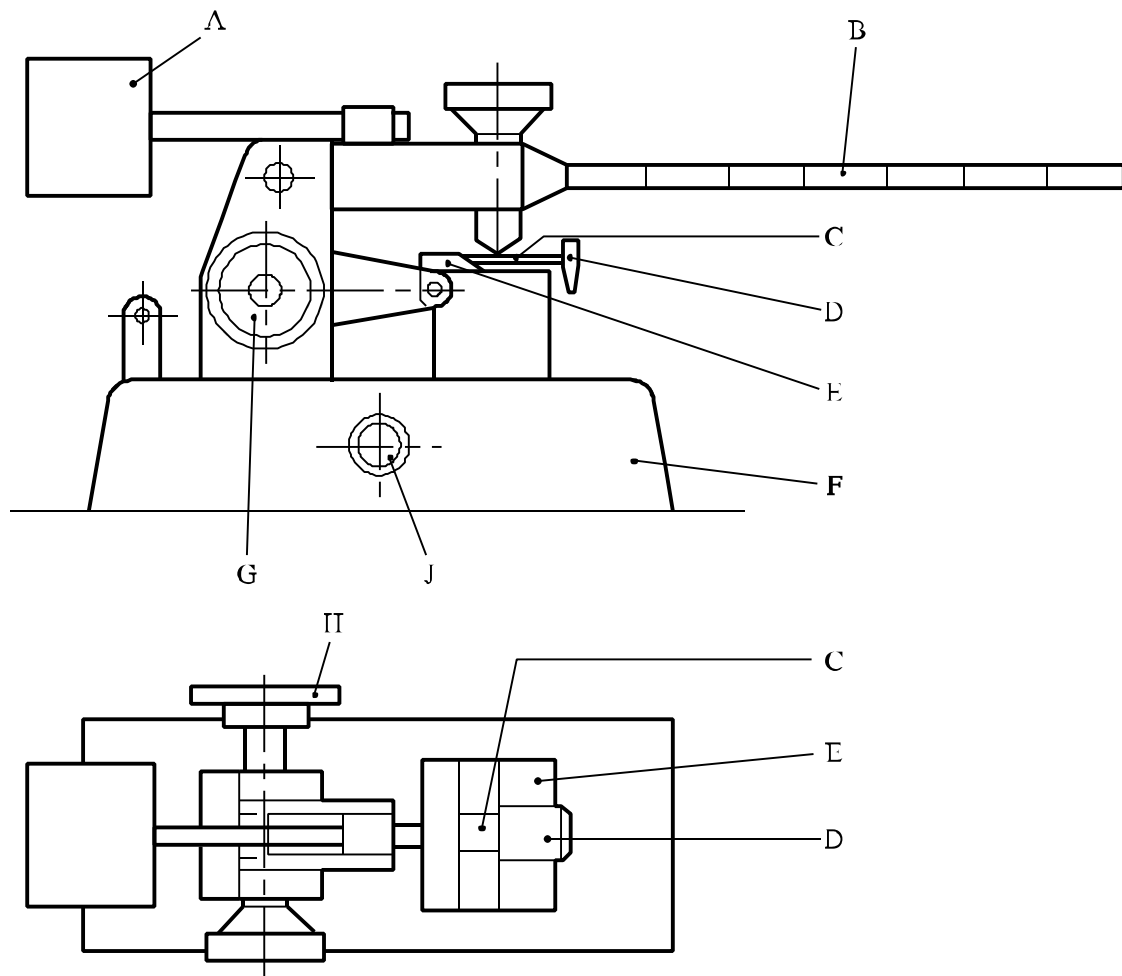
- (a) Whether an "explosion" occurs in any of up to six trials at a particular friction load;
- (b) The lowest friction load at which at least one "explosion" occurs in six trials.

The test result is considered "+" if the lowest friction load at which one "explosion" occurs in six trials is less than 80 N and the substance is considered ~~too dangerous for transport unstable~~ in the form in which it was tested. Otherwise, the test result is considered "-".

13.5.1.5 *Examples of results*

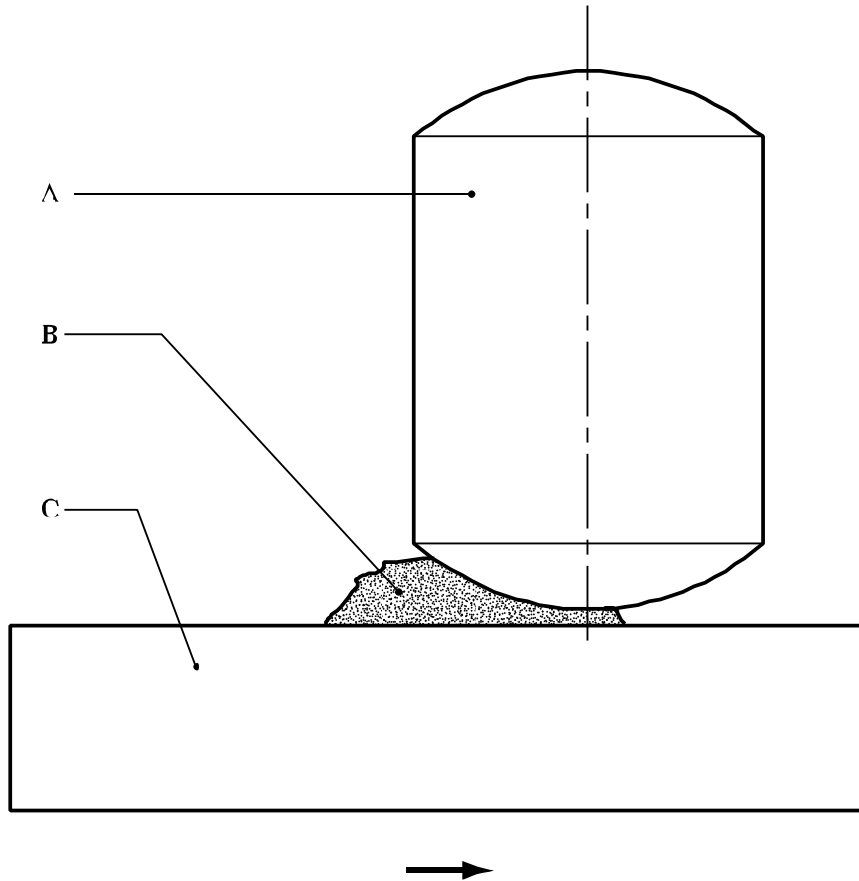
Substances	Limiting load (N)	Result
Blasting gelatine (75% NG)	80	-
Hexanitrostilbene	240	-
HMX (dry)	80	-
Hydrazine perchlorate (dry)	10	+
Lead azide (dry)	10	+
Lead styphnate	2	+
Mercury fulminate (dry)	10	+
Nitrocellulose 13.4% N (dry)	240	-
Octol 70/30 (dry)	240	-
PETN (dry)	60	+
PETN/wax 95/5	60	+
PETN/wax 93/7	80	-
PETN/wax 90/10	120	-
PETN/water 75/25	160	-
PETN/lactose 85/15	60	+
Picric acid (dry)	360	-
RDX (dry)	120	-
RDX (water wet)	160	-
TNT	360	-





- (A) Counter weight
- (B) Loading arm
- (C) Porcelain plate held on carriage
- (D) Adjusting rod
- (E) Movable carriage
- (F) Steel base
- (G) Handle for setting the carriage at the starting position
- (H) Points the direction to electric motor drive
- (J) Switch

Figure 13.5.1.1: BAM FRICTION APPARATUS



- 
- (A) Porcelain peg 10 mm diameter × 15 mm  
(B) Sample under test  
(C) Porcelain plate 25 × 25 × 5 mm
- 

**Figure 13.5.1.2: PORCELAIN PLATE AND PEG**

## 13.5.2 *Test 3 (b) (ii): Rotary friction test*

### 13.5.2.1 *Introduction*

This test is used to measure the sensitiveness of the substance to mechanical frictional stimuli and to determine if the substance is ~~too dangerous to transport unstable~~ in the form tested. The principle of operation is to hold a thin sample under a load between the prepared surfaces of a flat bar and the periphery of a wheel of specified diameter.

### 13.5.2.2 *Apparatus and materials*

The apparatus is shown diagrammatically in Figure 13.5.2.1. The bar (A) is made of general purpose mild steel whose surface has been prepared by grit-blasting to a finish of  $3.2 \mu\text{m} \pm 0.4 \mu\text{m}$ . A similar grit-blasting treatment is applied to the periphery of the wheel (C), made of the same steel and is 70 mm diameter by 10 mm thick. The sample under test is either cut as a sliver or spread as a powder so that its thickness is no more than approximately 0.1 mm on the bar. The wheel is mounted on spigots on the end of a rotor, the other end of which holds a pivoted latch operated by a relay switching mechanism in the circuit of a solenoid. The load is applied by compressed air (B) to a predetermined pressure. When the firing switch is operated, this latch is moved into the path of a striker on the periphery of a heavy flywheel which drives the rotor and, therefore, the wheel through  $60^\circ$ , after which the friction surfaces are separated by means of a cam on the rotor and a push rod operated by the loading cylinder.

### 13.5.2.3 *Procedure*

In the normal procedure, the load is maintained using an air pressure of 0.275 MPa, except for very sensitive explosives, for which it may be necessary to use a smaller load. The angular velocity of the wheel is used as the variable parameter and is controlled by varying the speed of the motor which drives the flywheel. The initial velocity for starting a run is determined by testing at the step velocity which is closest to the mean of the nearest ignition and non-ignition, and repeating the process until these occur at adjacent step levels. In a normal test, a 50-shot Bruceton (see Appendix 2) run with a logarithmic step size of 0.10 is employed. If the Sample Comparison Test (SCT) procedure (see Appendix 2) is used, samples of the standard and the sample under test are fired alternately, a separate Bruceton run being operated for each. An ignition is usually identified by a flash or audible report, but even a little smoke or blackening of the sample is considered as an ignition for the purpose of the test. Each sample is used only once, as are the contacting surfaces of the bar and the wheel. In order to monitor the long-term behaviour of the equipment, regular measurements are carried out on a standard explosive viz. RDX, recrystallized from cyclohexanone and dried according to a standard method. Unless obtained from the SCT procedure, data for the standard is obtained from 50-shot running mean determinations.

### 13.5.2.4 *Test criteria and method of assessing results*

The test results are assessed on the basis of:

- (a) Whether an ignition is observed in a trial;
- (b) Determination of the median striking velocity for the RDX reference standard and the sample by the Bruceton method (see Appendix 2);
- (c) Comparison of the running mean median striking velocity of the standard ( $V_1$ ) with that of the sample ( $V_2$ ) using the equation:

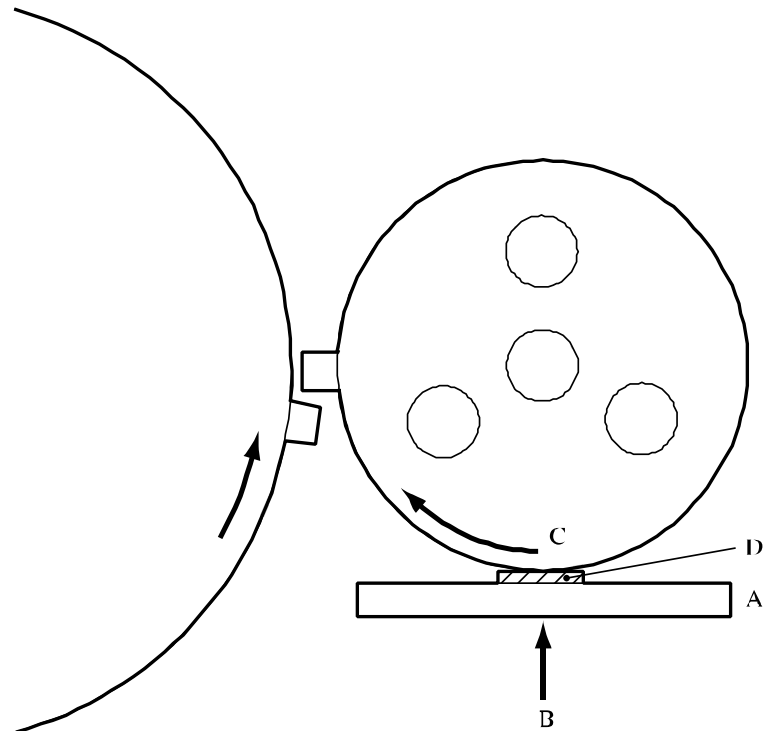
$$\text{Figure of Friction (F of F)} = 3.0 V_2/V_1$$

Standard RDX is assigned a F of F of 3.0.

The test result is considered "+" if the F of F is less than or equal to 3.0 and the substance is considered ~~too dangerous for transport unstable~~ in the form in which it was tested. The test result is considered "-" if the F of F is greater than 3.0. If the F of F obtained for the substance under test is less than 3.0, a direct comparison with the standard RDX may be made by using the SCT procedure with 100 shots on each substance. If there is 95% or greater confidence that the substance under test is not more sensitive than RDX, the substance under test is not ~~too dangerous for transport unstable~~ in the form tested.

13.5.2.5 *Examples of results*

<b>Substances</b>	<b>Figure of Friction</b>	<b>Result</b>
Blasting gelatine-geophex	2.0	+
Blasting gelatine-submarine	1.3	+
Lead azide	0.84	+
PETN/wax 90/10	4.0	-
RDX	3.4	-
Tetryl	4.5	-
TNT	5.8	-



- 
- (A) Mild steel bar
  - (B) Compressed air load
  - (C) Rotating wheel in contact with sample
  - (D) Sample
- 

**Figure 13.5.2.1: ROTARY FRICTION TEST**

### 13.5.3 *Test 3 (b) (iii): Friction sensitivity test*

#### 13.5.3.1 *Introduction*

This test is used to measure the sensitiveness of the substance to mechanical frictional stimuli and to determine if the substance is ~~too dangerous to transport unstable~~ in the form tested.

#### 13.5.3.2 *Apparatus and materials*

13.5.3.2.1 The general design of the friction test apparatus is given in Figure 13.5.3.1. The apparatus consists of four main components: pendulum, pendulum holder, apparatus body and hydraulic press. The apparatus is mounted on a concrete base. The roller assembly 1 with explosive under test is placed in the apparatus body. The compression of the explosive sample, placed between two rollers, up to the prescribed pressure is carried out by means of a hydraulic press. The movement of the upper roller along the substance by 1.5 mm is carried out using impact from the pendulum weight.

13.5.3.2.2 The roller assembly 1 consists of a sleeve and two rollers. Its dimensions and requirements are shown in Figure 13.5.3.2.

#### 13.5.3.3 *Procedure*

13.5.3.3.1 As a rule, substances should be tested as received. Wetted substances are to be tested with the minimum quantity of the wetting agent required ~~for transport~~. The substances should be subjected to the following procedures:

- (a) Granulated, flaky, pressed, cast and in other ways packed substances are milled and sieved; the substance particles for test should pass through the sieves with  $0.50 \pm 0.05$  mm mesh sides;
- (b) Elastic substances are cut into pieces not more than 1 mm in size with a sharpened knife on a wooden surface. Elastic substances samples are not sieved;
- (c) Powdered, plastic and pasty explosives samples are not ground and sieved.

Before use, the roller assemblies are degreased. The devices may be used again if they remain within specification.

13.5.3.3.2 To determine the lower friction sensitivity limit of tested explosive, the 20 mg of sample is placed into the open roller assembly. By gently pressing and turning the upper roller, the explosive sample is evenly smoothed between the rollers. The roller assembly containing the explosive sample is placed into the chamber of the apparatus body where it is compressed up to the chosen pressure. The sleeve is lowered by maintaining the pressure so that the explosive sample is pressed between roller faces and is raised above the sleeve. A striking pin is then moved so that its impact end touches the roller. The striking pin is impacted by the pendulum weight causing friction between the upper roller and the sample. The roller movement is 1.5 mm. The throw-off angle for the pendulum is chosen according to the following table, depending upon the retaining pressure of the sample. The tests are performed until the maximum retaining pressure is found which does not give an explosion in 25 trials. An explosion is considered to have occurred if there is a sound effect, a flash or burn traces on the rollers. The lower friction sensitivity limit is considered as the maximum retaining pressure which gives no explosion in 25 tests and which distinguishes from the pressure which still gives explosions but differ by not more than:

10 MPa - at test pressure up to 100 MPa

20 MPa - at test pressure 100 to 400 MPa

50 MPa - at test pressure above 400 MPa.

If no explosion is obtained in 25 tests at a pressure of 1 200 MPa, the lower friction sensitivity limit is expressed as "1 200 MPa or more". If one or more explosions are obtained in 25 tests at a pressure of 30 MPa, the lower friction sensitivity is expressed as "less than 30 MPa".

**RELATIONSHIP BETWEEN RETAINING PRESSURE OF EXPLOSIVE SAMPLE AND THROW-OFF ANGLE OF PENDULUM PROVIDING THE CONSTANT VALUE OF ROLLER SHIFT**

Retaining pressure of explosive sample (MPa)	Throw-off angle of pendulum (° from vertical)	Retaining pressure of explosive sample (MPa)	Throw-off angle of pendulum (° from vertical)
30	28	40	32
50	35	60	38
70	42	80	43
90	46	100	47
120	54	140	58
160	61	180	64
200	67	220	70
240	73	260	76
280	78	300	80
320	82	340	83
360	84	380	85
400	86	450	88
500	91	550	93
600	95	650	97
700	100	750	101
800	103	850	106
900	107	950	108
1 000	110	1 100	115
1 200	118		

13.5.3.4 *Test criteria and method of assessing results*

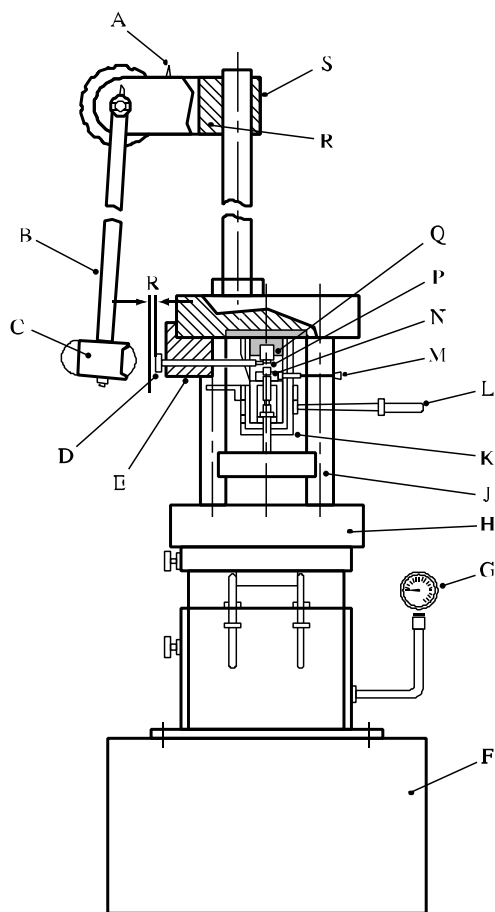
The test results are assessed on the basis of:

- (a) Whether an "explosion" occurs in any one of 25 trials; and
- (b) The maximum retaining pressure at which there is no explosion in any of 25 trials.

The test result is considered "+" if the lower impact friction sensitivity limit is less than 200 MPa and the substance is considered ~~too dangerous for transport~~ unstable in the form in which it was tested. The test result is considered "-" if the lower impact friction sensitivity limit is greater than or equal to 200 MPa.

13.5.3.5 *Examples of results*

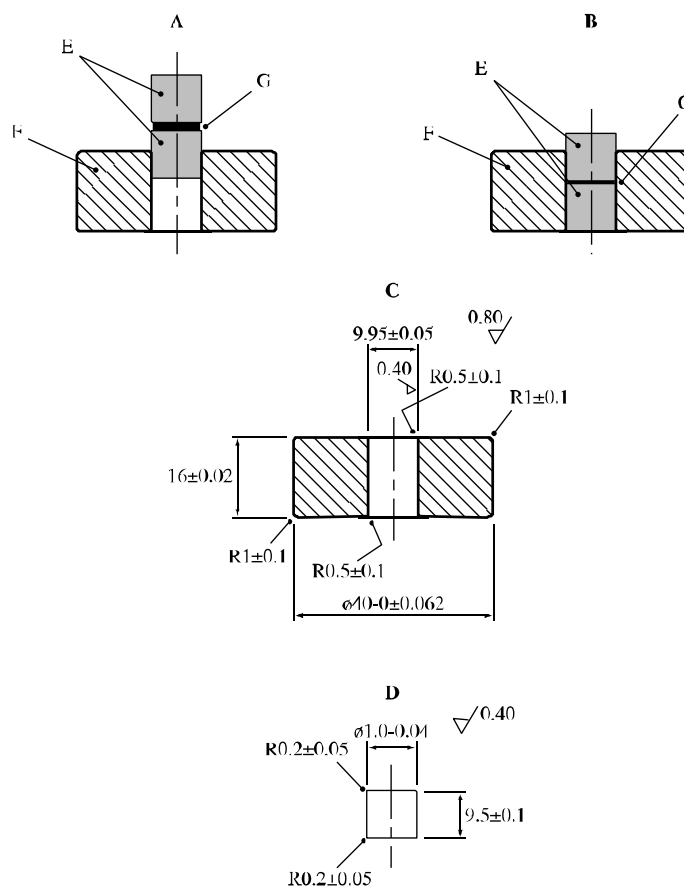
Substances	Lower limit (MPa)	Result
Ammonium nitrate	1 200	-
Lead Azide	30	+
PETN (dry)	150	+
PETN/paraffin (95/5)	350	-
PETN/TNT (90/10)	350	-
PETN/water (75/25)	200	-
Picric acid	450	-
RDX (dry)	200	-
RDX/water (85/15)	350	-
TATB	900	-
TNT	600	-



- 
- |   |                            |
|---|----------------------------|
| (A) Trigger                                       | (B) Pendulum lever         |
| (C) Pendulum weight                               | (D) Striking pin           |
| (E) Guide for striking pin                        | (F) Base                   |
| (G) Pressure gauge                                | (H) Hydraulic press        |
| (J) Apparatus support                             | (K) Apparatus body         |
| (L) Handle for lowering of roller assembly sleeve | (M) Roller assembly pusher |
| (N) Sleeve  | (P) Roller                 |
| (Q) Chamber                                       | (R) Pendulum holder        |
| (S) Pendulum holder support                       |                            |
- 

**Figure 13.5.3.1: APPARATUS FOR IMPACT FRICTION TEST**





- (A) Initial position of rollers
- (B) Rollers in position for test
- (C) Sleeve of tool carbon steel HRC 57 - 61
- (D) Roller of ball bearing steel HRC 63 - 66
- (E) Rollers
- (F) Sleeve
- (G) Substance under test

Figure 13.5.3.2: ROLLER ASSEMBLY 1

### 13.5.4 *Test 3 (b) (iv): ABL friction machine test*

#### 13.5.4.1 *Introduction*

This test is used to measure the sensitiveness of the substance to friction stimuli and to determine if the substance is ~~too dangerous to transport unstable~~ in the form tested. The test substance is subjected to a vertical compression force under a non-rotating wheel, while the substance is moved in a horizontal direction on a sliding anvil. It is applicable to solid, semisolid, and powder substances.

#### 13.5.4.2 *Apparatus and materials*

13.5.4.2.1 The following apparatus and materials are required:

- (a) A mechanism capable of applying a force hydraulically through a non-rotating steel wheel to a sample placed on steel anvil. Both the wheel and anvil have a surface roughness of 1.3 – 1.8  $\mu\text{m}$  and a Rockwell C hardness of 55 – 62.
- (b) A pendulum system that is capable of being positioned and released at an angle that will impart a predetermined velocity to the sliding anvil. A travel distance of approximately 2.5 cm perpendicular to the applied force on the wheel is achieved with this system.

#### 13.5.4.3 *Procedure*

13.5.4.3.1 As a rule, substances are tested in the form in which they are received. Wetted substances should be tested with the minimum quantity of wetting agent required ~~for transport~~. Depending on the physical form, the substances should then be subjected to the following procedures:

- (a) Powders are to be tested on the anvil in a monolayer; i.e., the thickness of the granular material, if possible. Place enough granules on the anvil to approximately cover an area 1.3 cm long by 0.65 cm wide starting about 0.65 cm behind the initial contact point of the wheel with the anvil such that the wheel will be in total contact with the sample when lowered onto it.
- (b) Solid propellants are tested in the form of thin, uniform slices with a thickness of 0.08 + 0.01 cm. This thickness is easily obtainable with the use of a microtome cutting tool.
- (c) Semisolids will be smoothed with a spatula to a thin layer with uniform thickness approximately 0.015 cm.

With the friction wheel raised, the test substance is placed on the anvil below the wheel such that the wheel will be in total contact with the sample when lowered onto it. The friction wheel is then carefully lowered onto the substance on the anvil and the desired normal force is applied to the wheel {250 N at 2.4 m/s or 445 N at 1.2 m/s}. The pendulum is raised to the desired angle to achieve the appropriate test velocity and released. Observations are made on whether a “reaction” occurs as evidenced by audible report or production of smoke, fire, charring or visible light as observed by human senses. The type of reaction that occurs is documented. The force on the wheel is removed and any excess test substance is cleaned from the area. The wheel is indexed and shifted across the anvil in order to ensure that fresh surfaces are used for each trial.

#### 13.5.4.4 *Maintenance and calibration*

The maximum speed of the anvil should be calibrated to 2.4 m/s and 1.2 m/s. The downward force on the wheel should be verified. The test machine should be periodically cleaned and calibrated according to a schedule based on the amount of usage. At a minimum, the machine should be calibrated on an annual basis.

#### 13.5.4.5 *Test criteria and method of assessing results*

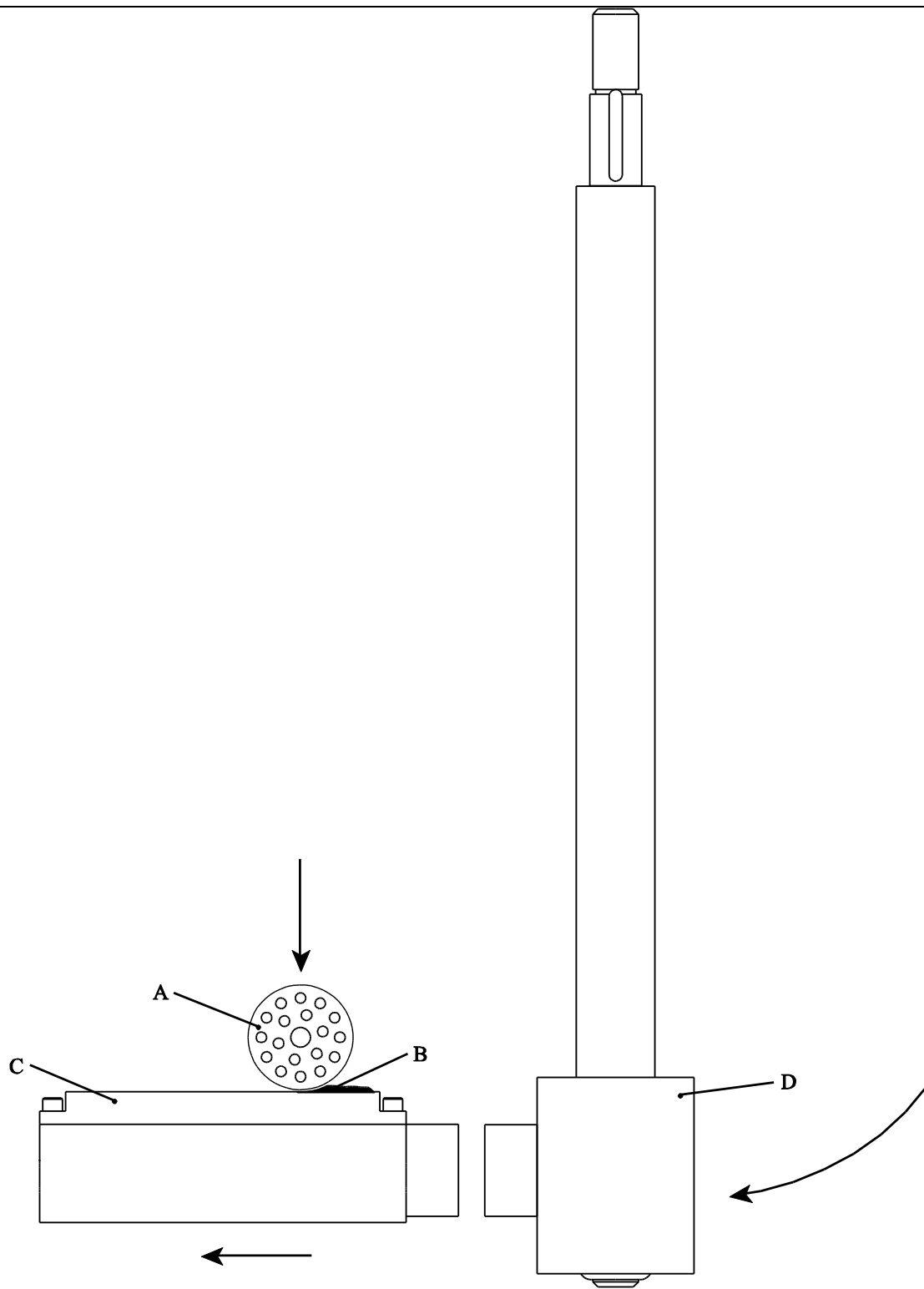
The test result is considered “+” if the lowest friction load at which at least one reaction occurs in six trials is 250 N at 2.4 m/s or 445 N at 1.2 m/s or less and the substance is considered ~~too dangerous for transport unstable~~ in the form in which it was tested. Otherwise, the result is considered “-”.

13.5.4.6 *Examples of results*

<b>Substances<sup>1</sup></b>	<b>Result</b>
RDX (class 5)	–
RDX (class 7)	–
PBXN-8	–
PBXN-10	–
Aluminium/TNT (80/20 Mixture)	–
PETN (dry) <sup>2</sup>	+

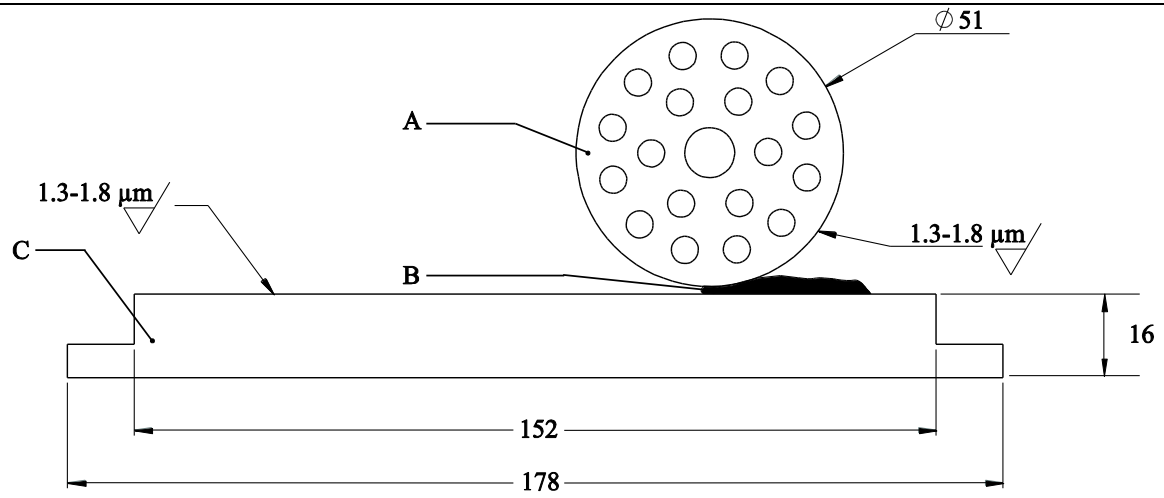
<sup>1</sup> *Data acquired at 2.4 m/s, relative humidity of 10-30%, and temperature of 16-24 °C unless noted otherwise.*

<sup>2</sup> *Data acquired at 2.4 m/s and 1.2 m/s.*



- |                        |              |
|------------------------|--------------|
| (A) Non-rotating wheel | (B) Sample   |
| (C) Anvil              | (D) Pendulum |

Figure 13.5.4.1: ABL Friction machine



- (A) Non-rotating wheel 5.1 cm diameter maximum × 3.18 cm
- (B) Sample under test
- (C) Anvil 18 cm × 5.7 cm × 1.6 cm maximum

**Figure 13.5.4.2: ABL Friction machine wheel and anvil detail**

### 13.6 Series 3 type (c) test prescription

#### 13.6.1 Test 3 (c) (i): Thermal stability test at 75 °C

##### 13.6.1.1 Introduction

This test is used to measure the thermal stability of the substance when subjected to elevated thermal conditions ~~to determine if the substance is too dangerous to transport.~~

##### 13.6.1.2 Apparatus and materials

13.6.1.2.1 The following apparatus is required:

- (a) An electric oven equipped with ventilation, explosion-proof electrical features, and thermostatic control adequate to maintain and record the temperature at  $75 \pm 2$  °C. The oven should have dual thermostats or some kind of protection against thermal run-away if the thermostat malfunctions;
- (b) A lipless beaker of 35 mm diameter and 50 mm high and a watch-glass of 40 mm diameter;
- (c) A balance capable of determining the sample weight to  $\pm 0.1$  g;
- (d) Three thermocouples and a recording system;
- (e) Two flat-bottomed glass tubes of  $50 \pm 1$  mm diameter and 150 mm length and two 0.6 bar (60 kPa) pressure resisting stoppers.

13.6.1.2.2 An inert substance, whose physical and thermal properties are similar to the test substance, should be used as the reference substance.

##### 13.6.1.3 Procedure

13.6.1.3.1 ***In dealing with a new substance, several screening tests, involving heating small samples at 75 °C for 48 hours, are performed to explore its behaviour.*** If no explosive reaction occurs using a small amount of substance, the procedure given in 13.6.1.3.2 or 13.6.1.3.3 should be used. If explosion or ignition occurs then the substance is considered ~~to be~~ thermally unstable, shall be classified as an unstable explosive and is not permitted for transport.

13.6.1.3.2 Uninstrumented test: A 50 g sample is weighed into a beaker, covered and placed in an oven. The oven is heated to 75 °C and the sample left at oven temperature for 48 hours or until ignition or explosion occurs, whichever is sooner. If ignition or explosion does not occur but there is evidence, e.g. fuming or decomposition, that some self-heating has occurred, the procedure given in 13.6.1.3.3 should be performed. However, if the substance shows no evidence of thermal instability, it may be regarded as thermally stable and no further testing of this property is necessary.

***Note by the secretariat:*** This is a correction to be included in a forthcoming corrigendum to the 6th revised edition of the Manual (i.e. it should not be considered as an amendment and therefore it will not be included in the consolidated list of amendments to the 6th revised edition).

13.6.1.3.3 Instrumented test: A 100 g (or 100 cm<sup>3</sup> if the density is less than 1 000 kg /m<sup>3</sup>) sample is placed in one tube and the same quantity of reference substance is placed in the other. Thermocouples T<sub>1</sub> and T<sub>2</sub> are inserted into the tubes at half-height of the substances. If the thermocouples are not inert with respect to both the substance being tested and the reference substance, they should be enclosed in sheaths which are inert. Thermocouple T<sub>3</sub> and the covered tubes are placed in the oven as shown in Figure 13.6.1.1. The temperature difference (if any) between test sample and reference is measured for 48 hours after the sample and any reference substance reach 75 °C. Evidence of decomposition of the sample is noted.

13.6.1.4 *Test criteria and method of assessing results*

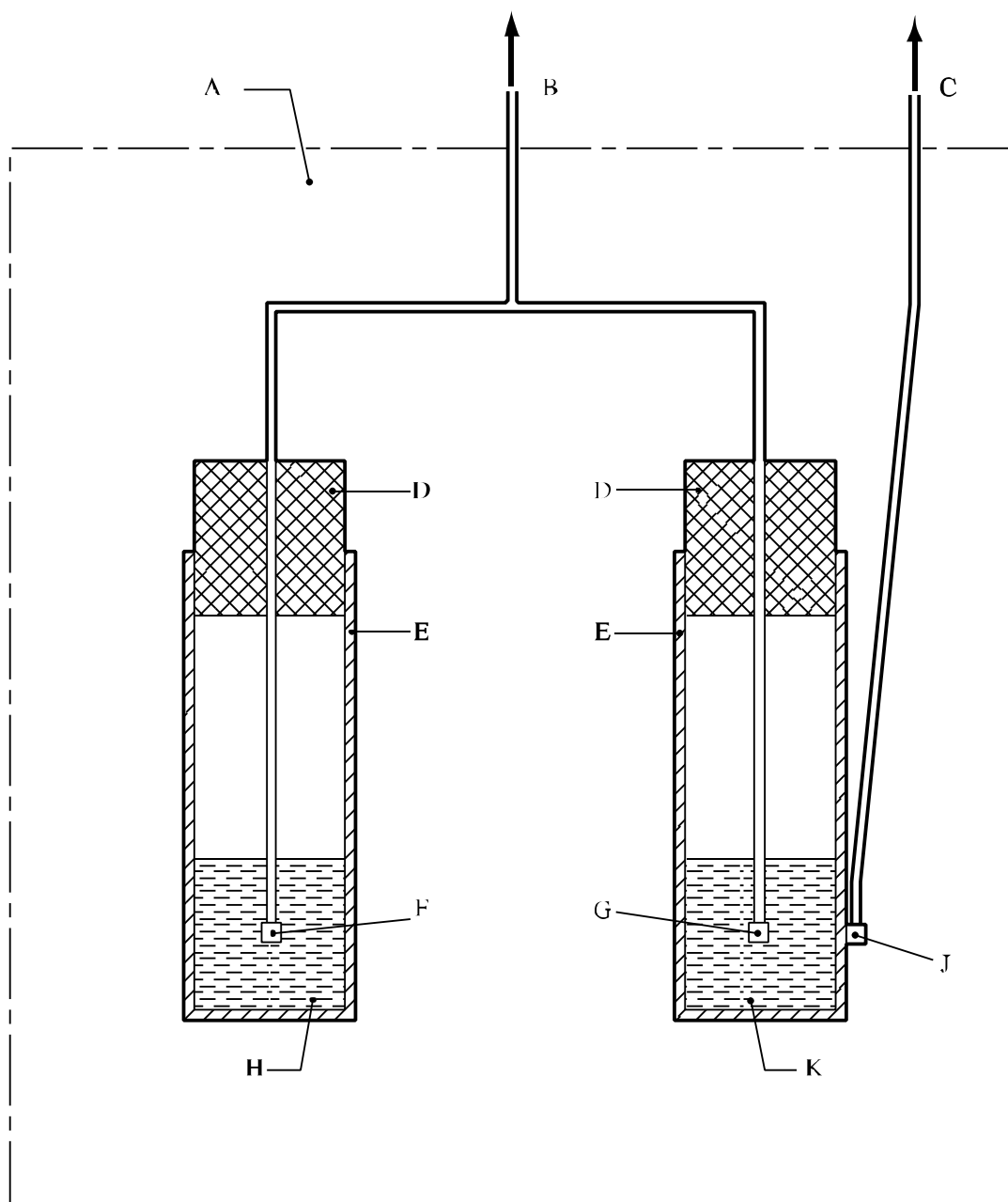
13.6.1.4.1 The result from an uninstrumented test is considered "+" if ignition or explosion occurs and "-" if no changes are observed. The result of a instrumented test is considered "+" if an ignition or explosion occurs or if a temperature difference (i.e. self-heating) of 3 °C or greater is recorded. If no ignition or explosion occurs but self-heating of less than 3 °C is noted, additional tests and/or evaluation may be required to determine if the sample is thermally unstable.

13.6.1.4.2 If the test result is "+", the substance should be considered ~~too~~ thermally unstable, [shall be classified as an unstable explosive and is not permitted](#) for transport.

13.6.1.5 *Examples of results*

Substances	Observations	Result
70% AP, 16% Al, 2.5% Catocene, 11.5% binder	Oxidation reaction took place on Catocene (burning rate catalyst). Sample discoloured on the surface, but there was no chemical decomposition.	-
PETN/Wax 90/10	Negligible mass loss	-
RDX, 22% water wetted	Mass loss < 1%	-
Gelatine dynamite (NG 22%, DNT 8%, Al 3%)	Negligible mass loss	-
ANFO explosive	Mass loss < 1%	-
Slurry explosives <sup>a</sup>	Negligible mass loss, slight (eventual) swelling	-

<sup>a</sup> *Various types.*



- |     |                             |     |  |
|-----|-----------------------------|-----|--|
| (A) | Heating oven                | (B) | To millivoltmeter ( $T_1 - T_2$ )          |
| (C) | To millivoltmeter ( $T_3$ ) | (D) | Stoppers                                   |
| (E) | Glass tubes                 | (F) | Thermocouple No 1 ( $T_1$ )                |
| (G) | Thermocouple No 2 ( $T_2$ ) | (H) | 100 cm <sup>3</sup> of sample              |
| (J) | Thermocouple No 3 ( $T_3$ ) | (K) | 100 cm <sup>3</sup> of reference substance |

Figure 13.6.1.1: EXPERIMENTAL SET-UP FOR STABILITY TEST AT 75 °C



**13.6.2**      *Test 3(c) (ii): SBAT thermal stability test at 75 °C*13.6.2.1      *Introduction*

This test is used to measure the thermal stability of the substance when subjected to elevated thermal conditions ~~to determine if the substance is too dangerous for transport.~~

13.6.2.2      *Apparatus and materials*

## 13.6.2.2.1      The following apparatus is required:

- (a) Glass sample tubes of 13 x 100 mm inside a larger tube of 25 x 100 mm. Each 13 x 100 mm tube is surrounded by insulation and placed into the larger tube. Each larger glass tube has insulation surrounding it further isolating it thermally from the metal oven block. The glass sample tube can be sealed to prevent the escape of gases.
- (b) A well-insulated multiport metal block that can be heated with resistance heaters to a temperature of at least 260 °C. The heating of the block must be automated or reliably controlled so that the desired temperature can be maintained within  $\pm 0.5$  °C. The heated block should have independent protection against excessively heating the block in the event of a primary control system failure. Each port in the metal block should have a diameter of 5 cm and a depth of 10 cm.
- (c) The temperature decay time constant,  $\tau$ , for the configuration outlined in (a) and (b) should be at least 10 minutes. The decay constant,  $\tau$ , is found by heating 5 grams of an inert material (e.g. dried silica, alumina, or silicone) in the sample tube (13 x 100 mm test tube) to a temperature 50 °C or more higher than the constant temperature of the SBAT. The heated sample tube is placed into the SBAT apparatus (into the larger glass tube with internal and external insulation as previously described). The sample will cool to the constant temperature of the oven. While cooling, the sample temperature is recorded. The decaying temperature will be exponential in shape and is fit to the following equation:

$$(T - T_a)/(T_i - T_a) = \exp(-t/\tau)$$

where  $T$  is the inert reference temperature that varies with time,  $T_a$  is the constant oven temperature,  $T_i$  is the initial reference temperature,  $t$  is time and  $\tau$  is the temperature decay time constant.

- (d) An inert material (e.g. dried silica, alumina or silicone) to be used as a reference which is also placed into insulated glass tubes (13 x 100 mm inside the larger 25 x 100 mm tube) with the same insulation configuration as the sample.
- (e) Thermocouples with a data recording system to record the temperature of the reference and sample(s) as well as thermocouple(s) to measure and control the oven temperature.

13.6.2.3      *Procedure*

13.6.2.3.1      Five grams of the sample or an amount that fills the tube to 75 mm height, whichever is less, is placed inside one of the sample tubes. A second sample tube is filled with the same amount of sample. One of the filled sample tubes is not sealed whereas the second filled sample tube is sealed with a screw cap or other method. For the sample tube that is sealed, the thermocouple is attached to the sidewall of the sample tube. For the open sample tube, the thermocouple can be attached to the side of the tube or inserted into the sample.

13.6.2.3.2      Each sample tube is then surrounded with insulation and placed into the larger 25 x 100 mm tube which is also insulated from the side walls of the SBAT oven ports. The approximately 5 gram reference sample must also be present in one of the SBAT ports with the same insulation configuration as the sample. The samples are heated to 75–77 °C and maintained at that temperature for 48 hours. Sample and reference temperatures are recorded throughout the test.

13.6.2.3.3 Once the test has been completed, additional test data may be obtained by linearly increasing the temperature of the apparatus to determine the thermal profile of the sample (measuring endotherms and exotherms, as evidenced by departures of the sample from the temperature of the inert reference).

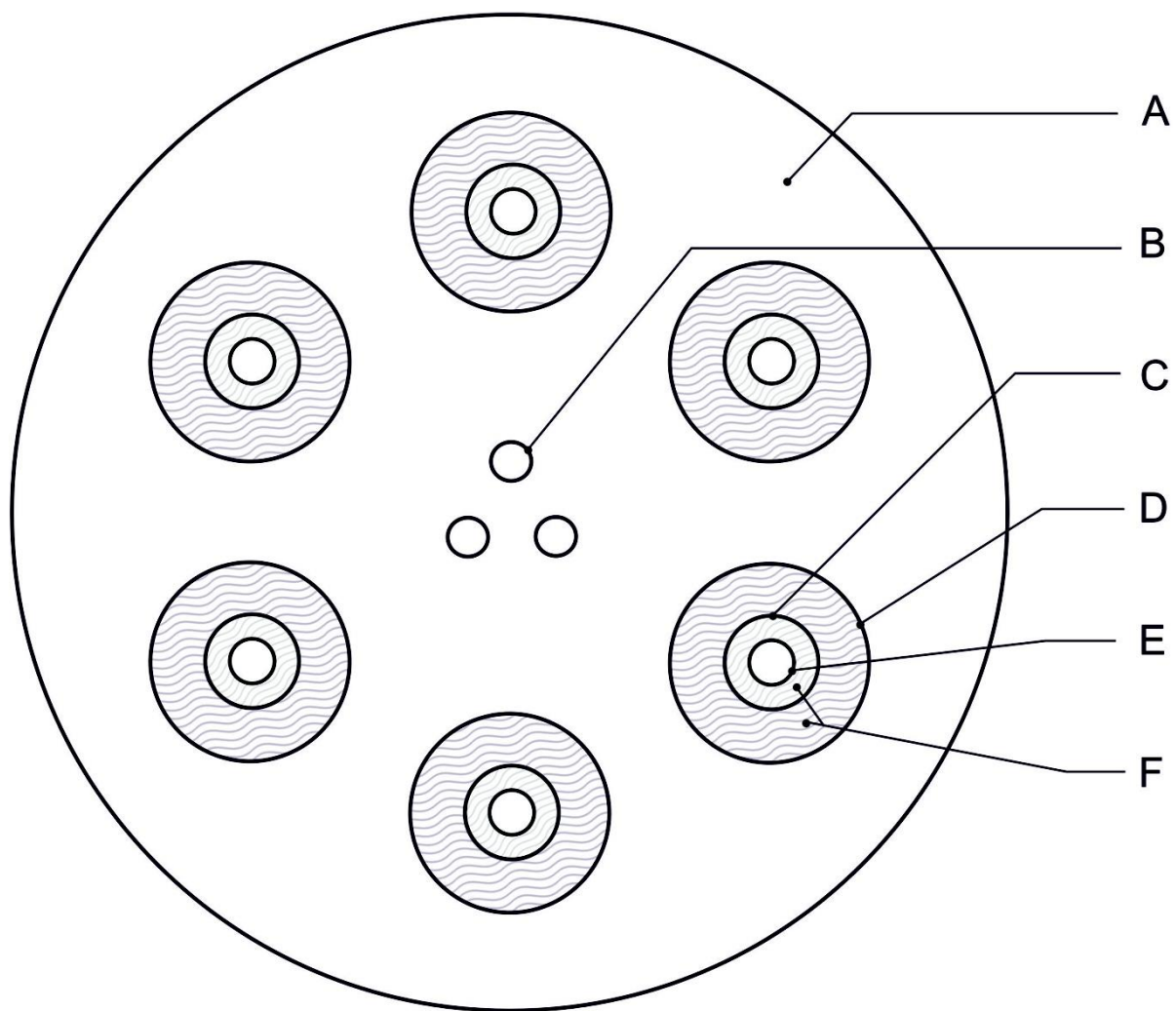
13.6.2.4 *Test criteria and method of assessing results*

13.6.2.4.1 The result from a test is considered “+” if either the sealed or unsealed sample shows more than a 1.5 °C temperature rise during the 48 hour test period indicating self-heating.

13.6.2.4.2 If the test result is “+”, the substance should be considered ~~too~~ thermally unstable, [shall be classified as an unstable explosive and is not permitted](#) for transport.

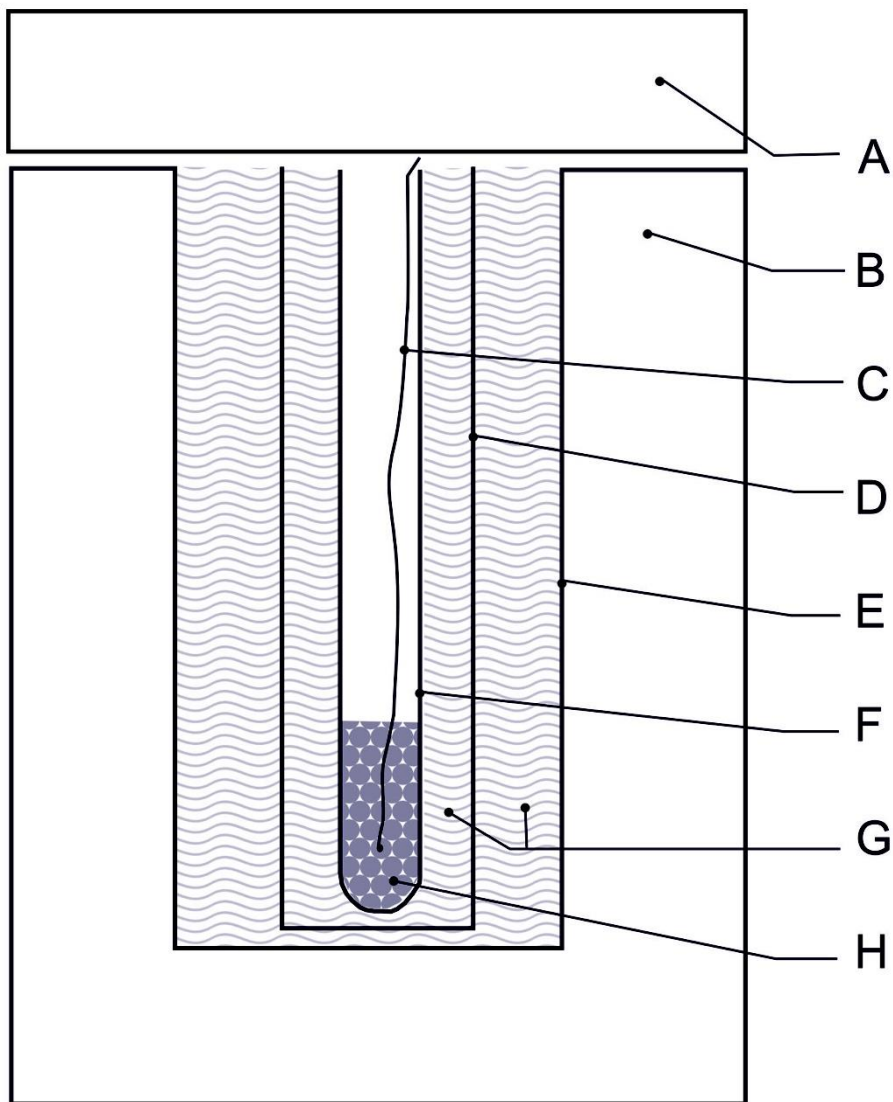
13.6.2.5 *Examples of results*

Substances	Temperature Rise	Result
PETN	Less than 1.5 °C	–
RDX	Less than 1.5 °C	–
TNT	Less than 1.5 °C	–
Composition B, reclaimed	Less than 1.5 °C	–
Double base smokeless powder, 40% NG	Less than 1.5 °C	–
Black powder	Less than 1.5 °C	–
Barium styphnate	Less than 1.5 °C	–
Rocket motor propellant (60-70% AP, 5-16% Al, 12-30% binder)	Less than 1.5 °C	–
Catalyst containing copper acetylide	Greater than 1.5 °C	+



- |     |                        |     |                   |
|-----|------------------------|-----|-------------------|
| (A) | Metal block            | (B) | Cartridge heaters |
| (C) | Glassware              | (D) | Sample port       |
| (E) | Glass sample container | (F) | Insulation        |

Figure 13.6.2.1: SBAT Heating Block



- 
- |     |                           |     |                        |
|-----|---------------------------|-----|------------------------|
| (A) | Insulative cap or blanket | (B) | Metal block            |
| (C) | Thermocouple              | (D) | Glassware              |
| (E) | Sample port               | (F) | Glass sample container |
| (G) | Insulation                | (H) | Sample                 |
- 

Figure 13.6.2.2: SBAT Port

## 13.7 Series 3 type (d) test prescription

### 13.7.1 Test 3 (d): Small-scale burning test

This test is used to determine the response of a substance to fire.

#### 13.7.1.1 Apparatus and materials

##### 13.7.1.1.1 Solids and liquids

Sufficient Kerosene-soaked sawdust (approximately 100 g of sawdust and 200 cm<sup>3</sup> of kerosene) is required to make a bed 30 cm × 30 cm and 1.3 cm thick. For substances which do not readily ignite, the thickness is increased to 2.5 cm. An electric igniter and a thin-walled plastics beaker, just sufficient in size to contain the test substance and compatible with it, are also required.

##### 13.7.1.1.2 Alternative method (solids only)

A chronometer and a sheet of Kraft paper of 30 cm × 30 cm, placed on a non-flammable surface, are required. A few grammes of fine smokeless powder and a suitable means of ignition are used as described in the procedure and shown in Figure 13.7.1.1.

#### 13.7.1.2 Procedure

##### 13.7.1.2.1 Solids and liquids

10 g of the substance is placed in the beaker. The beaker is placed centrally on a bed of kerosene-soaked sawdust and the sawdust is ignited with the electric igniter. The test is performed twice with 10 g of sample and twice with 100 g, unless an explosion is observed.

##### 13.7.1.2.2 Alternative method (solids only)

A conical pile of the substance is placed on the sheet of Kraft paper, the height of the pile being equal to the radius at the base. A trail of smokeless powder surrounds the pile of substance under test and this trail is ignited, by a suitable source of ignition applied from a safe distance, at two diagonally opposite points (see Figure 13.7.1.1). The Kraft paper is ignited by the trail of smokeless powder and transmits the flame to the test substance. The test is performed twice with 10 g and twice with 100 g of sample, unless an explosion is observed.

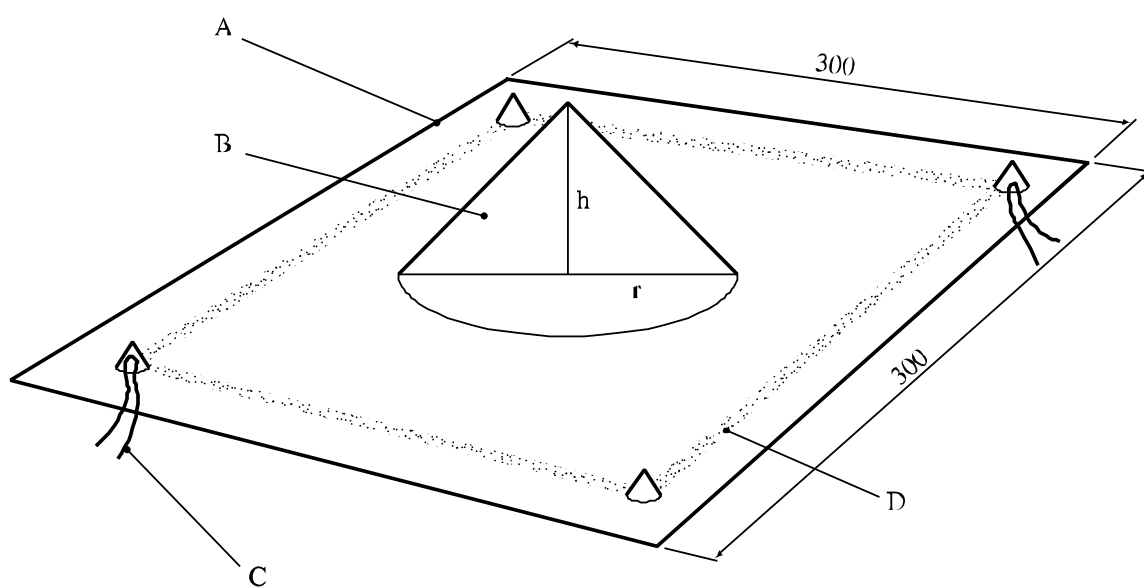
#### 13.7.1.3 Test criteria and method of assessing results

The event is observed visually and the result is reported as one of the following three categories:

- (a) Fails to ignite;
- (b) Ignites and burns; or
- (c) Explodes.

The duration of the combustion, or the time to explosion, may be noted to provide additional information. The test result is considered "+" if any explosion of the test samples occurs and the substance is considered to be ~~too dangerous for transport-unstable~~ in the form in which it is tested. Otherwise, the test result is considered "-".

<b>Substances</b>	<b>Observations</b>	<b>Result</b>
Liquids		
Nitromethane	Burning	-
Solids		
<i>Alternative method</i>		
Blasting gelatin A (NG 92%, cellulose nitrate 8%)	Burning	-
Black powder Pulverin	Burning	-
Lead azide	Explosion	+
Mercury fulminate	Explosion	+



- (A) Sheet of kraft paper
- (B) Test substance
- (C) Ignition by an igniter and a few grams of fine smokeless powder (at two opposite corners)
- (D) Trail of fine smokeless powder

**Figure 13.7.1.1: SMALL SCALE BURNING TEST (for solids)**





**SECTION 14****TEST SERIES 4****14.1 Introduction**

14.1.1 Series 4 tests are intended to answer the question "Is the article, packaged article or packaged substance ~~too dangerous for transport~~unstable?" (box 16 of Figure 10.2). Conditions which may ~~occur during transport~~be encountered include high temperature and high relative humidity, low temperature, vibration, bumping and dropping. The two types of test to be carried out are:

Type 4 (a): a test of thermal stability for articles; and

Type 4 (b): a test to determine the danger from dropping.

14.1.2 The question in box 16 is answered "Yes" if a "+" is obtained in either test type 4 (a) or 4 (b).

**14.2 Test methods**

The test methods currently used are listed in Table 14.1.

**Table 14.1: TEST METHODS FOR TEST SERIES 4**

<b>Test code</b>	<b>Name of Test</b>	<b>Section</b>
4 (a)	Thermal stability test for unpackaged articles and packaged articles <sup>a</sup>	14.4.1
4 (b) (i)	The steel tube drop test for liquids <sup>a</sup>	14.5.1
4 (b) (ii)	Twelve metre drop test for articles, packaged articles and packaged substances <sup>a</sup>	14.5.2

<sup>a</sup> *Recommended test.*

**14.3 Test conditions**

14.3.1 The tests are carried out on the packaged substance, packaged article(s) and, if intended to be ~~transported-classified~~unpackaged, on the article itself. The minimum size unit acceptable for a type 4 (a) test is the smallest packaged unit or an individual ~~unpacked~~article, if ~~appropriate~~~~transported-unpackaged~~. Test 4 (b) (i) should be applied to homogeneous liquids; and test 4 (b) (ii) should be applied to unpackaged, ~~if appropriate~~, and packaged articles and to packaged substances other than homogeneous liquids.

**14.4 Series 4 type (a) test prescriptions****14.4.1 Test 4 (a): Thermal stability test for unpackaged articles and packaged articles****14.4.1.1 Introduction**

This test is used to evaluate the thermal stability of articles and packaged articles when subjected to elevated thermal conditions to determine whether the unit being tested is too hazardous for transport. The minimum size unit acceptable for this test is the smallest packaged unit or, if ~~appropriate~~~~transported-unpackaged~~, the unpackaged article. ~~In general, the package as used for transport should be tested.~~ If this is not possible (e.g. it is too large for the oven), a similar, smaller package should be used filled with the maximum number of articles possible.

14.4.1.2 *Apparatus and materials*

This test requires an oven equipped with a fan and thermostatic control to maintain the temperature at  $75 \pm 2$  °C. It is desirable that the oven should have dual thermostats or similar protection against excessively high temperatures in the event of a thermostat malfunction. A unit should be fitted with a thermocouple connected to a temperature recorder to assess any exothermic temperature increase.

14.4.1.3 *Procedure*

Depending on the unit being tested, a thermocouple is placed either on the outside casing of the unpackaged article, or on the outside casing of an article which is located near the centre of its package. The thermocouple is attached to a temperature recorder. The unit to be tested (together with the thermocouple) is placed in the oven, heated to 75 °C and maintained at that temperature for 48 hours. The oven is then allowed to cool and the unit then removed from the oven and inspected. Temperatures are recorded and signs of reaction, damage or exudation noted.

14.4.1.4 *Test criteria and method of assessing results*

The test result is considered "+" and the article or packaged article(s) is considered thermally unstable, shall be classified as an unstable explosive and is not permitted to be dangerous for transport if:

- (a) It explodes;
- (b) It ignites;
- (c) It experiences a temperature rise exceeding 3 °C;
- (d) The outer casing of the article or the outer packaging is damaged; or
- (e) Dangerous exudation occurs i.e. explosive is visible outside the article(s).

The result is considered "-" if there are no external effects and there is no temperature rise exceeding 3 °C.

14.4.1.5 *Examples of results*

No examples of results are given as these are too specific to the packaging or article tested

<b>Article tested</b>	<b>Result</b>
<del>Cylindrical fountains</del>	<del>_____</del>
<del>Delay electric igniter</del>	<del>_____</del>
<del>Hand signal device</del>	<del>_____</del>
<del>Railway torpedo</del>	<del>_____</del>
<del>Roman candle</del>	<del>_____</del>
<del>Safety squib</del>	<del>_____</del>
<del>Signal flare</del>	<del>_____</del>
<del>Small arms ammunition</del>	<del>_____</del>
<del>Smoke candle</del>	<del>_____</del>
<del>Smoke grenade</del>	<del>_____</del>
<del>Smoke pot</del>	<del>_____</del>
Smoke signal	-

**14.5 Series 4 type (b) test prescriptions**

**14.5.1 Test 4 (b) (i): The steel tube drop test for liquids**

14.5.1.1 *Introduction*

This test is used to determine the explosive behaviour of an homogeneous energetic liquid, in a closed steel tube, when it is dropped from various heights onto a steel anvil.

14.5.1.2 *Apparatus and materials*

The steel (A37 type) tube is 33 mm inner diameter, 42 mm outer diameter, and 500 mm long (see figure 14.5.1.1). It is filled with the liquid under test and closed at the upper end by a cast-iron threaded cap sealed with polytetrafluoroethylene (PTFE) tape. The cap has an 8 mm hole, for filling, drilled axially and the hole is closed by a plastics plug.

14.5.1.3 *Procedure*

The temperature and density of the liquid are noted. One hour or less before the test, the liquid is agitated for 10 seconds. The height of drop is varied in steps of 0.25 m to a maximum of 5 m. The procedure consists of finding the maximum height at which there is no detonation. The tube falls in a vertical orientation. It is noted whether, and at what height, any of the following occur:

- (a) Detonation with fragmentation of the tube;
- (b) A reaction causing the tube to burst; or
- (c) No reaction with little damage to the tube.

14.5.1.4 *Test criteria and method of assessing results*

If detonation takes place after a drop of 5 m or less, the test result is "+" and the liquid ~~is considered too dangerous to be transported~~ shall be classified as an unstable explosive and is not permitted for transport.

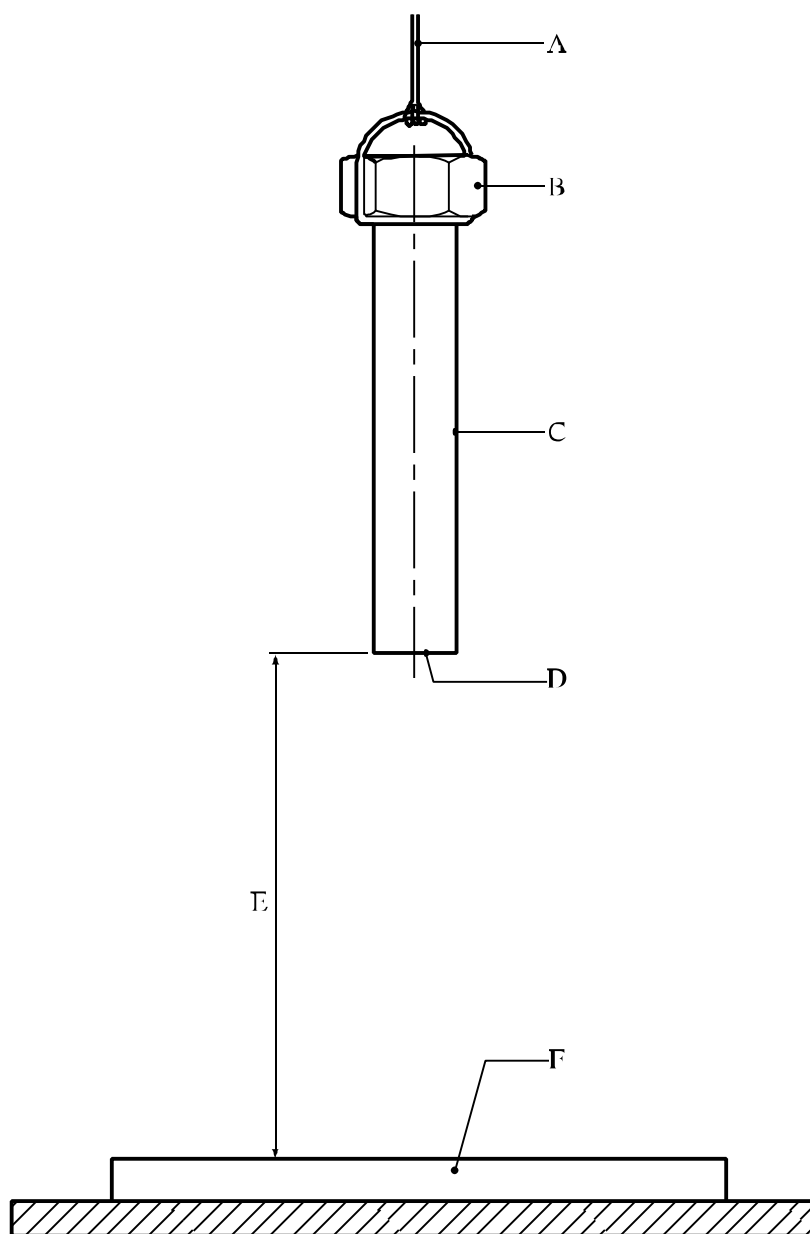
Where there is a local reaction without detonation after a 5 m drop, the test result is "-" but metal packaging should not be used unless its ~~application suitability for transport~~ has been demonstrated to be safe to the satisfaction of the competent authority.

If there is no reaction after a drop from 5 m, the test result is "-" and it is considered that the liquid can be ~~transported included in the class of explosives~~ in any form of packaging suitable for liquids.

14.5.1.5 *Examples of results*

~~No examples of results are given as these are too specific to the packaging or article tested~~

<del>Liquid</del>	<del>Temperature (° C)</del>	<del>Drop height for detonation (m)</del>	<del>Result</del>
<del>Nitroglycerine</del>		<del>←</del>	<del>+</del>
<del>Nitroglycerine/Triacetin/2-NDPA (78/21/1)</del>		<del>0.25</del>	<del>+</del>
<del>Nitromethane</del>	<del>15</del>	<del>→</del>	<del>—</del>
<del>TEGDN</del>	<del>14</del>	<del>5.00</del>	<del>—</del>
	<del>15</del>	<del>→</del>	
	<del>13</del>	<del>5.00</del>	



- 
- |                                     |   |
|-------------------------------------|---|
| (A) Release by fusing of wire       | (B) Cast-iron threaded cap                          |
| (C) Seamless steel tube             | (D) Welded-steel base (thickness 4 mm)              |
| (E) Drop height of 0.25 m to 5.00 m | (F) Steel anvil (1 m × 0.50 m and thickness 0.15 m) |
- 

**Figure 14.5.1.1: THE STEEL DROP TEST FOR LIQUIDS**

**14.5.2**      *Test 4 (b) (ii): Twelve metre drop test for unpackaged articles, packaged articles and packaged substances*

14.5.2.1      *Introduction*

This test determines whether a test unit (article, packaged article(s) or packaged substance (other than homogeneous liquids)) can withstand a free-fall impact without producing any significant fire or explosion hazard. It is not intended as a test to evaluate whether the package will withstand impact.

14.5.2.2      *Apparatus and materials*

14.5.2.2.1      Impact surface

The impact surface is a solid base with a reasonably smooth surface. An example of such a surface is as follows: a steel plate, with a minimum thickness of 75 mm and Brinell hardness of not less than 200, solidly supported by a concrete foundation having a minimum thickness of 600 mm. The length and width of the surface should be not less than one and a half times the dimension of the unit being tested.

14.5.2.2.2      Other apparatus

Photographic or other visual recording devices should be used to verify impact attitude and results. Where impact attitude may be considered to be a significant factor, the test agency may use guidance devices to obtain the desired impact attitude. Such devices should not significantly restrain drop velocity, nor impede rebound after impact.

14.5.2.2.3      Materials

In certain cases, some of the explosive articles in a package of articles under test may be replaced with inert articles. These inert articles should be of the same mass and volume as the explosive articles they replace. The explosive articles should be located in the position where they are most likely to function on impact. If a packaged substance is tested, none of the substance may be replaced by inert material.

14.5.2.3      *Procedure*

The test unit is dropped from a height of 12 m as measured from the lowest point of the test unit to the impact surface. ***A safe waiting period, prescribed by the test agency, should be observed after impact, even if no visible initiation or ignition occurs at impact.*** The test unit should then be further examined to determine if any ignition or initiation has occurred. Three drops are made on the packaged substance or article unless a decisive event (e.g. fire or explosion) occurs earlier. However, each test unit is dropped only once. The data recorded should include the package description and observations. Recorded results should include photographs and recorded visual and audible evidence of ignition, time of occurrence (if any), and indication of severity of the results in terms such as mass detonation or deflagration. The attitude of the test unit at impact should also be recorded. Rupture of the package may be noted but does not affect the conclusion.

14.5.2.4      *Test criteria and method of assessing results*

The test result is considered "+" ~~and the packaged substance or article(s) too dangerous to transport~~ if a fire or explosion resulted from impact. The article, packaged article(s) or packaged substance shall then be classified as an unstable explosive and is not permitted for transport. Rupture of the package or article casing alone is not considered a "+" result. The result is considered "-" if no fire or explosion occurred in any of the three drops.

14.5.2.5 *Examples of results*

No examples of results are given as these are too specific to the packaging or article tested

Substances or article(s)	Number of drops	Observations	Results
Cable cutter cartridge, metal box containing two devices		No reaction	
Cast primers (27.2 kg)		No reaction	
CBI solid propellants 7.11 mm diameter (36.3 kg)		No reaction	
Component (of projectile) containing detonator, primer and fuze assembly		No reaction	
Dynamite, ammonia gelatin (22.7 kg)		Ignition	
Dynamite, 40% strength ammonia (22.7 kg)		No reaction	
Dynamite, 60% strength straight (22.7 kg)		No reaction	
Dynamite, 50% strength straight "ditching" (22.7 kg)		No reaction	
Propellant gas generator 61.7 kg net mass in aluminium container		No reaction	
Demolition firing device, wooden box containing 20 individually packed devices		No reaction	
		No reaction	
		No reaction	
		No reaction	
		No reaction	

---

**SECTION 15****TEST SERIES 5****15.1 Introduction**

15.1.1 The results from three types of series 5 tests are used to answer the question "Is it a very insensitive explosive substance with a mass explosion hazard?" (box 21 of Figure 10.3). The test types are:

Type 5 (a): a shock test to determine the sensitivity to intense mechanical stimulus;

Type 5 (b): thermal tests to determine the tendency of transition from deflagration to detonation; and

Type 5 (c): a test to determine if a substance, when in large quantities, explodes when subjected to a large fire.

15.1.2 The question in box 21 is answered "No" if a "+" is obtained in any of the three test types i.e. a candidate for Division 1.5 should pass a test of each type.

**15.2 Test methods**

The test methods currently used are listed in Table 15.1.

**Table 15.1: TEST METHODS FOR TEST SERIES 5**

Test code	Name of Test	Section
5(a)	Cap sensitivity test <sup>a</sup>	15.4.1
5 (b) (i)	French DDT test	15.5.1
5 (b) (ii)	USA DDT test <sup>a</sup>	15.5.2
5 (b) (iii)	Deflagration to detonation test	15.5.3
5 (c)	External fire test for Division 1.5 <sup>a</sup>	15.6.1

<sup>a</sup> *Recommended test.*

A test of each type should be performed.

**15.3 Test conditions**

15.3.1 As the density of the substance has an important effect on the results from type 5 (a) and 5 (b) tests, the density should be determined. The sample mass and density should always be recorded.

15.3.2 The tests should be performed at ambient temperature unless the substance is [likely to encounter to be transported under](#) conditions where it may change its physical state or density.

## 15.4 Series 5 type (a) test prescription

### 15.4.1 Test 5 (a): Cap sensitivity test

#### 15.4.1.1 Introduction

This shock test is used to determine the sensitiveness of a substance to intense mechanical stimulus.

#### 15.4.1.2 Apparatus and materials

The experimental set up for the cap sensitivity test is shown in figures 15.4.1.1 and 15.4.1.2 and consists of a cardboard tube of minimum diameter 80 mm and length 160 mm with a maximum wall thickness of 1.5 mm, closed at the base with a membrane just sufficient to retain the sample. The intense mechanical stimulus is provided by a standard detonator (see Appendix 1) inserted centrally in the top of the explosive in the tube to a depth equal to its length. Below the tube is the witness, which consists of a 1.0 mm thick 160 × 160 mm steel plate, placed on a steel ring of 50 mm height, 100 mm inner diameter and 3.5 mm wall thickness (see Figure 15.4.1.1). Alternatively, a 51 mm diameter, 102 mm long cylinder of common (soft) lead (see Figure 15.4.1.2) may be used. The apparatus is placed onto a square shaped steel plate of 25 mm thickness and 152 mm sides.

#### 15.4.1.3 Procedure

The substance under test is filled into the tube in three equal increments. For free-flowing granular substances, the sample is consolidated by allowing the tube to fall vertically through a height of 50 mm after filling each increment. Gel-type substances are carefully packed to prevent adding voids. ~~In all cases, the final density of the explosive in the tube should be as close as possible to its shipping density.~~ For high-density cartridge explosives with a diameter greater than 80 mm, the original cartridge is used. Where such original cartridges are inconveniently large for testing, a portion of the cartridge not less than 160 mm long may be cut off and used for testing. In such cases the detonator is inserted into the end in which the substance has not been disturbed by the action of cutting the cartridge. Those explosives whose sensitivity could be temperature dependent should be stored for at least 30 hours at a temperature of 28 - 30 °C prior to testing. Explosives containing prilled ammonium nitrate, which ~~have to be transported in regions of~~ can be subjected to high ambient temperatures should be temperature cycled as follows: 25 °C → 40 °C → 25 °C → 40 °C → 25 °C prior to testing. The tube is placed onto the witness and steel base plate and the standard detonator inserted centrally into the top of the explosive. The detonator is then fired from a safe position and the witness examined. The test is conducted three times unless detonation of the substance occurs.

#### 15.4.1.4 Test criteria and method of assessing results

The result is considered "+" and the substance should not be classified in Division 1.5 if in any trial:

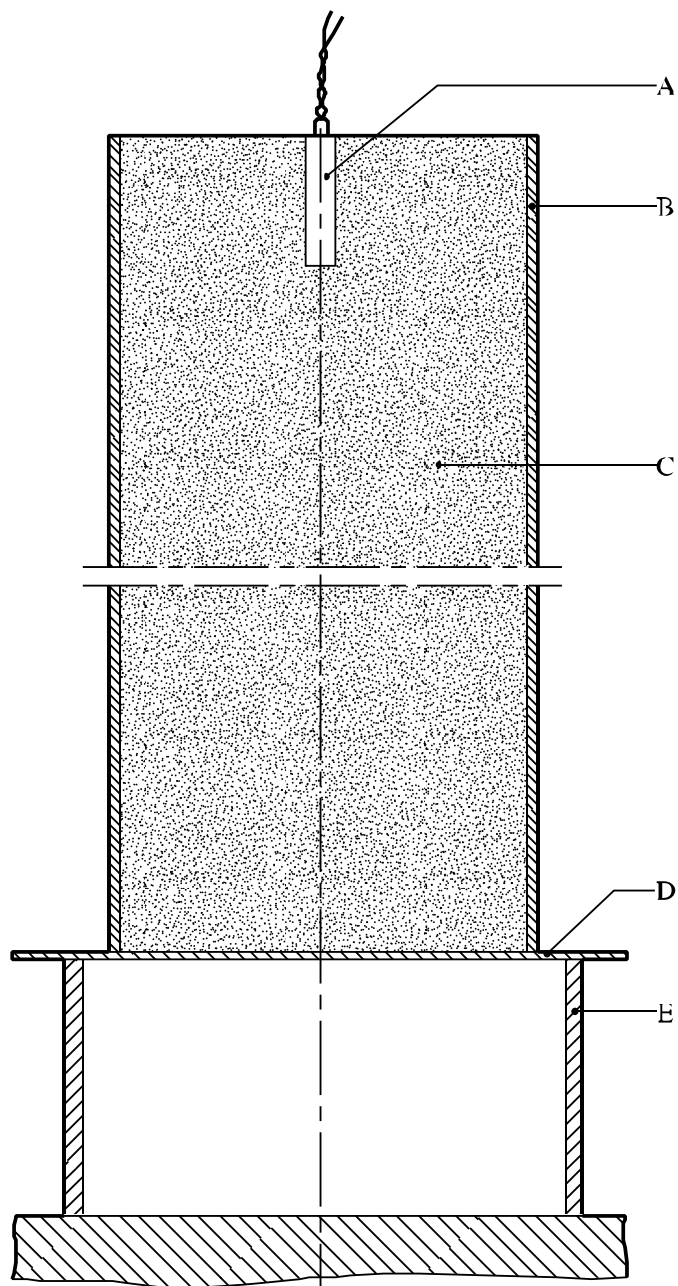
- (a) The witness plate is torn or otherwise penetrated (i.e. light is visible through the plate) - bulges, cracks or folds in the witness plate do not indicate cap sensitivity; or
- (b) The centre of the lead cylinder is compressed from its initial length by an amount of 3.2 mm or greater.

Otherwise, the result is considered "-".



15.4.1.5 *Examples of results*

<b>Substance</b>	<b>Density (kg/m<sup>3</sup>)</b>	<b>Remarks</b>	<b>Result</b>
Ammonium nitrate prills + fuel oil	840 - 900	Original	-
" " "	750 - 760	2 temperature cycles	+
Ammonium nitrate + TNT + combustible material	1 030 - 1 070	Original	+
Ammonium nitrate prills + DNT (on surface)	820 - 830	Original	-
" " "	800 - 830	30 hours at 40 °C	+
Ammonium nitrate + DNT + combustible material	970 - 1 030	Original	-
" " "	780 - 960	Original	+
Ammonium nitrate + combustible material	840 - 950	Original	-
" " "	620 - 840	Original	+
Ammonium nitrate + alkali nitrate + alkali-earth nitrate + Aluminium + water + combustible material	1 300 - 1 450	Original	-
" " "	1 130 - 1 220	Original	+
Ammonium nitrate + alkali nitrate + nitrate + TNT + Aluminium + water + combustible material	1 500	Original	-
" " "	1 130 - 1 220	Original	+
Ammonium nitrate/methanol (90/10), prilled			-
Ammonium nitrate/nitromethane, 87/13			+
ANFO (94/6), prills			-
ANFO (94/6), 200 µm			+
TNT, granular			+

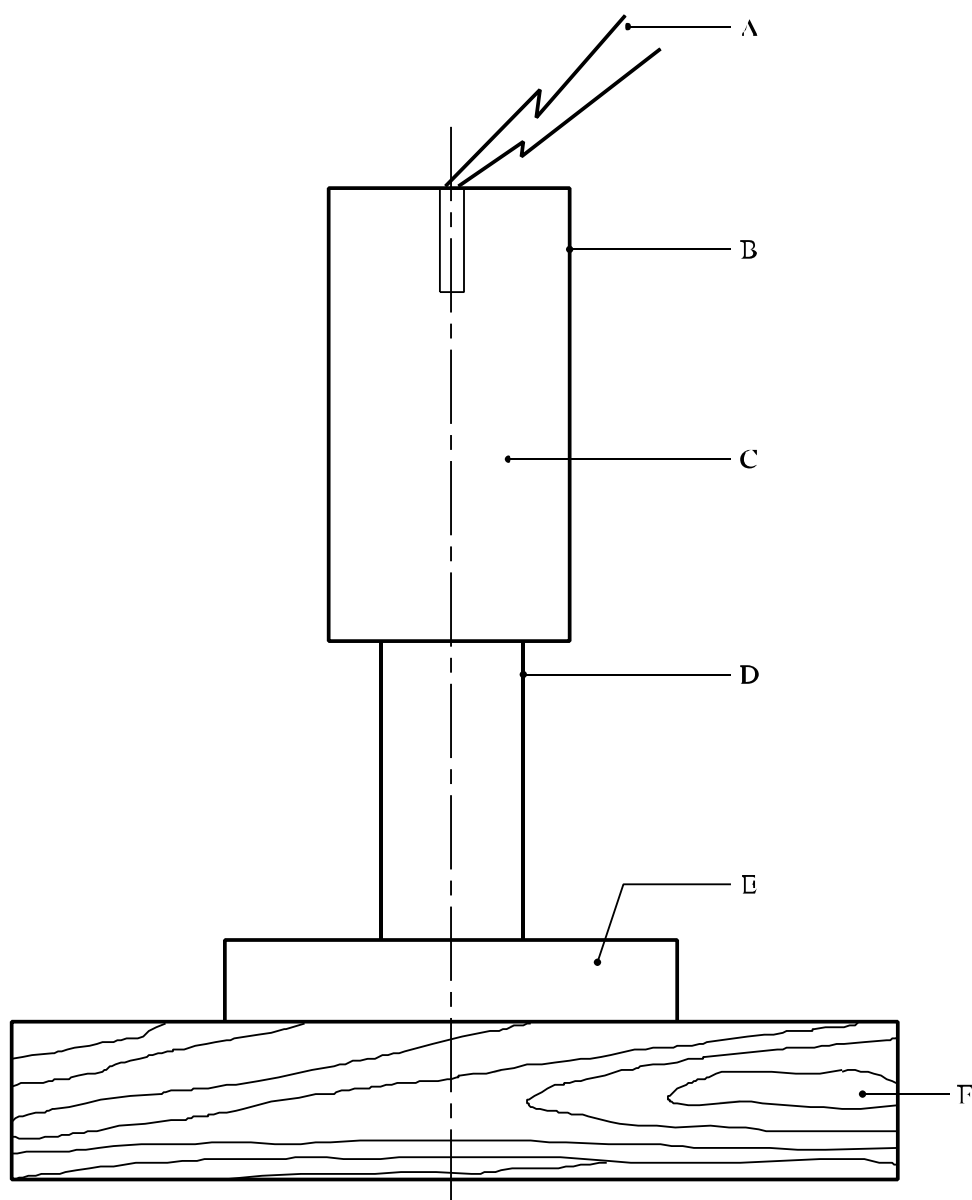


- 
- (A) Detonator
  - (C) Test substance (D)
  - (E) Steel ring

- (B) [Cardboard tube fibreboard spirally wound plys](#)
- Witness plate of normal structural steel

---

**Figure 15.4.1.1: CAP SENSITIVITY TEST (using steel witness plate)**



- (A) Electric detonator
- (B) Cardboard [tube container 8.6 cm diameter × 16.2 cm long](#)
- (C) Explosive sample
- (D) Lead cylinder
- (E) Steel plate [15 × 15 × 2.5 cm](#)
- (F) Wood block [30 × 30 × 5 cm](#)

**Figure 15.4.1.2: CAP SENSITIVITY TEST (using lead cylinder as witness)**

**15.5 Series 5 type (b) test prescriptions**

**15.5.1 Test 5 (b) (i): French DDT test**

15.5.1.1 *Introduction*

This test is used to determine the tendency for the substance to undergo transition from deflagration to detonation.

15.5.1.2 *Apparatus and materials*

The apparatus consists of a seamless steel tube (A37 type), inner diameter 40.2 mm, wall thickness 4.05 mm, and length 1 200 mm. The static resistance of the tube is 74.5 MPa. As shown in Figure 15.5.1.1, the tube is closed by two screwed caps and a probe for monitoring the shock wave velocity is fitted. The tube is placed horizontally onto a lead witness plate of thickness 30 mm. The substance is ignited by a heated wire, composed of Ni/Cr (80/20) with diameter 0.4 mm and length 15 mm, located at one end of the tube.

15.5.1.3 *Procedure*

The test substance is filled into the tube and compacted by hand compression. The temperature, density and water content of the substance should be recorded. A current of up to 8 A is used for a maximum of three minutes to heat the ignition wire and ignite the substance. The test is performed three times unless deflagration to detonation transition occurs as shown by compression of the lead witness plate or by the measured propagation velocity.

15.5.1.4 *Test criteria and method of assessing results*

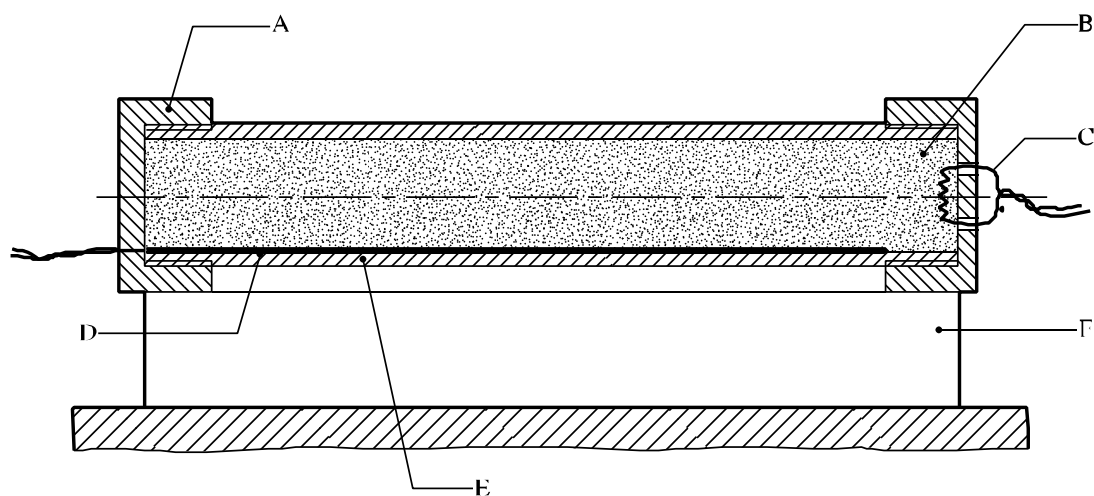
The test result is considered "+" and the substance should not be classified in Division 1.5 if in any trial detonation occurs. Evidence of detonation may be assessed by whether:

- (a) The lead witness plate is compressed in a manner characteristic of detonation; and
- (b) The measured propagation velocity is greater than the speed of sound in the substance and constant in the part of tube furthest from the initiator.

The length before detonation and the detonation velocity should be noted. The test result is considered "-" if the witness plate is not compressed and the speed of propagation, if measured, is less than the speed of sound in the substance.

15.5.1.5 *Examples of results*

Substance	Density (kg/m <sup>3</sup> )	Result
Aluminised gel (62.5% oxidising salts, 15% aluminium, 15% other combustibles)	1 360	-
ANFO (AN size 0.85 mm, oil retention 15%)	860	-
Gelatine-dynamite (NG/EGDN 40%, AN 48%, aluminium 8%, NC)	1 450	+
Guhr-dynamite (NG 60%, Guhr 40%)	820	+
Sensitized slurry explosive	1 570	-



- (A) Threaded cast-iron end caps
- (B) Test substance
- (C) Igniter wire
- (D) Velocity probe
- (E) Seamless steel tube
- (F) Lead witness plate

Figure 15.5.1.1: FRENCH DDT TEST

**15.5.2**            *Test 5 (b) (ii): USA DDT test*

15.5.2.1           *Introduction*

This test is used to determine the tendency of a substance to undergo transition from deflagration to detonation.

15.5.2.2           *Apparatus and materials*

The experimental arrangement is shown in Figure 15.5.2.1. The sample substance to be tested is contained in a 457 mm length of "3 inch schedule 80" carbon (A53 Grade B) steel pipe with inside diameter 74 mm, wall thickness 7.6 mm, capped at one end with a "3 000 pound" forged steel pipe cap, and at the other with a 13 cm square, 8 mm thick mild steel witness plate which is welded to the pipe. An igniter consisting of 5.0 g of black powder (100% passed through No. 20 sieve, 0.84 mm, and 100% retained by No. 50 sieve, 0.297 mm) is located at the centre of the sample vessel. The igniter assembly consists of a cylindrical container 21 mm in diameter which is made from 0.54 mm thick cellulose acetate which is held together by two layers of nylon filament reinforced cellulose acetate tape. The length of the igniter capsule is approximately 1.6 cm for the 5 g igniter. The igniter capsule contains a small loop formed from a 25 mm length of nickel-chromium alloy resistance wire 0.30 mm in diameter having a resistance of 0.343 ohms. This loop is attached to two insulated copper lead wires. These lead wires are fed through small holes in the wall of the pipe and are sealed with epoxy resin.

15.5.2.3           *Procedure*

After the sample, at ambient temperature, is loaded into the pipe to a height of 23 cm, the igniter (with its leads inserted through small holes in the pipe wall) is inserted into the centre of the pipe and the leads pulled taut and sealed with epoxy resin. The remainder of the sample is then loaded, and the top cap screwed on. For gelatinous samples, the substance is packed as near as possible to its normal shipping density. For granular samples, the substance is loaded to the density obtained by repeated tapping of the pipe against a hard surface. The tube is placed in a vertical position and the igniter is fired by a current of 15 amperes obtained from a 20-volt transformer. Three trials should be performed unless deflagration to detonation transition occurs earlier.

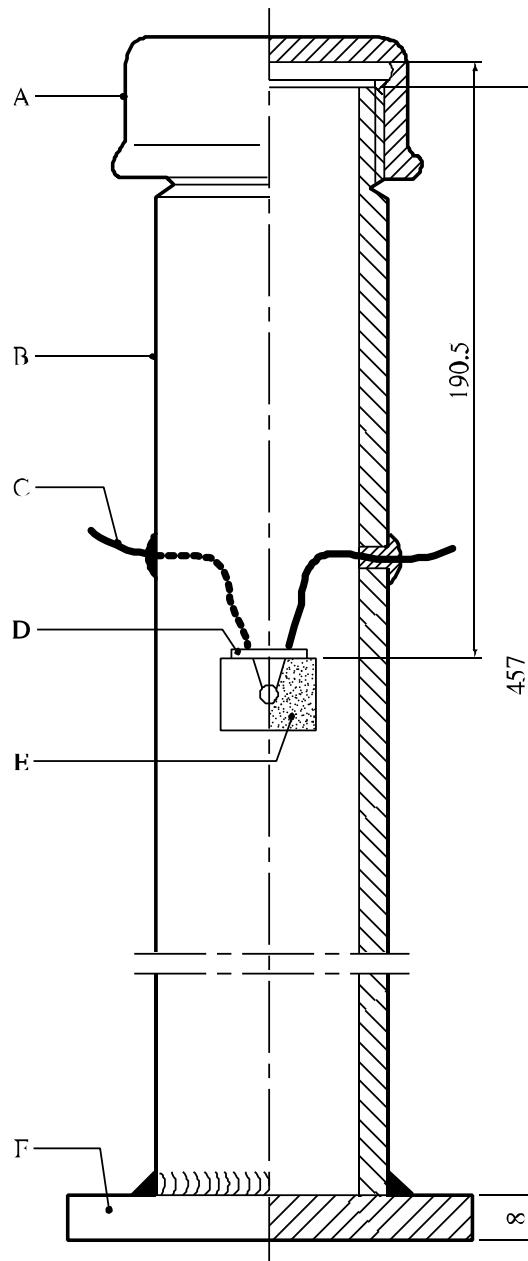
15.5.2.4           *Test criteria and method of assessing results*

The test result is considered "+" and the substance should not be classified in Division 1.5 if a hole is punched through the witness plate. If no hole is punched through the witness plate then the result is considered "-".

15.5.2.5           *Examples of results*

Substance	Apparent Density (kg/m <sup>3</sup> )	Result
Ammonium nitrate/fuel oil (94/6)	795	-
Ammonium perchlorate (200 µm) <sup>a</sup>	1 145	-
ANFO blasting agent (with low density combustible additive)	793	+
Emulsion blasting agent (sensitized with microballoons)	1 166	-
Emulsion blasting agent (sensitized with NC)	1 269	-
Emulsion blasting agent (sensitized with oil)	1 339	-
NG dynamite <sup>a</sup>	900	+
PETN (wetted with 25% water) <sup>a</sup>	1 033	+

<sup>a</sup>            *Used for calibration purposes - not for classification in Division 1.5.*



- (A) Forged steel cap
- (C) Igniter leads
- (E) Igniter assembly

- (B) Steel pipe
- (D) Seal
- (F) Witness plate

Figure 15.5.2.1: USA DDT TEST

**15.5.3**            *Test 5 (b) (iii): Deflagration to detonation transition test*

15.5.3.1           *Introduction*

This test is used to determine the tendency of a substance to undergo transition from deflagration to detonation.

15.5.3.2           *Apparatus and materials*

In comparative tests of DDT susceptibility, steel tubes with inner diameter of 40 mm, wall thickness of 10 mm and length of 1 000 mm are used. The breaking strength of the tube is 130 MPa (see Figure 15.5.3.1). One end of the tube is sealed by a metal threaded plug or other means of fastening such as a stud, screw or welding. The strength of the tube closure should not be less than the breaking strength of the tube. A threaded socket for the igniter is made in the tube wall 100 mm from the plug. The black powder igniter cases are made of mild steel. An electric squib is mounted in the case. Its conductivity is checked by a tester or ohmmeter and then  $3 \pm 0.01$  g of black powder (SGP No 1) is loaded into the case and the case opening sealed with plastic tape.

15.5.3.3           *Procedure*

The test substance is loaded into the tube at normal bulk density. An end of the 10 m length of 12 g/m detonating cord is inserted into the sample at the open end of the tube to a depth of 100 mm and the tube then sealed with plastic tape. The loaded tube is mounted horizontally on a steel plate. The other end of the detonating cord is attached to an aluminium plate of length 200 mm, width 50 mm, and thickness from 2 to 3 mm (Figure 15.5.3.1). The igniter is screwed into the tube wall, making sure that the threads are clean, and is connected to the firing line. The initiation of the test material is then performed. After firing, the tube is inspected. The rupture character is recorded (tube bulging, breaking into large fragments or crushing into small fragments), the presence or absence of unreacted substance and the presence or the absence of the detonating cord traces on the witness plate is determined. Three trials should be performed unless deflagration to detonation transition occurs earlier.

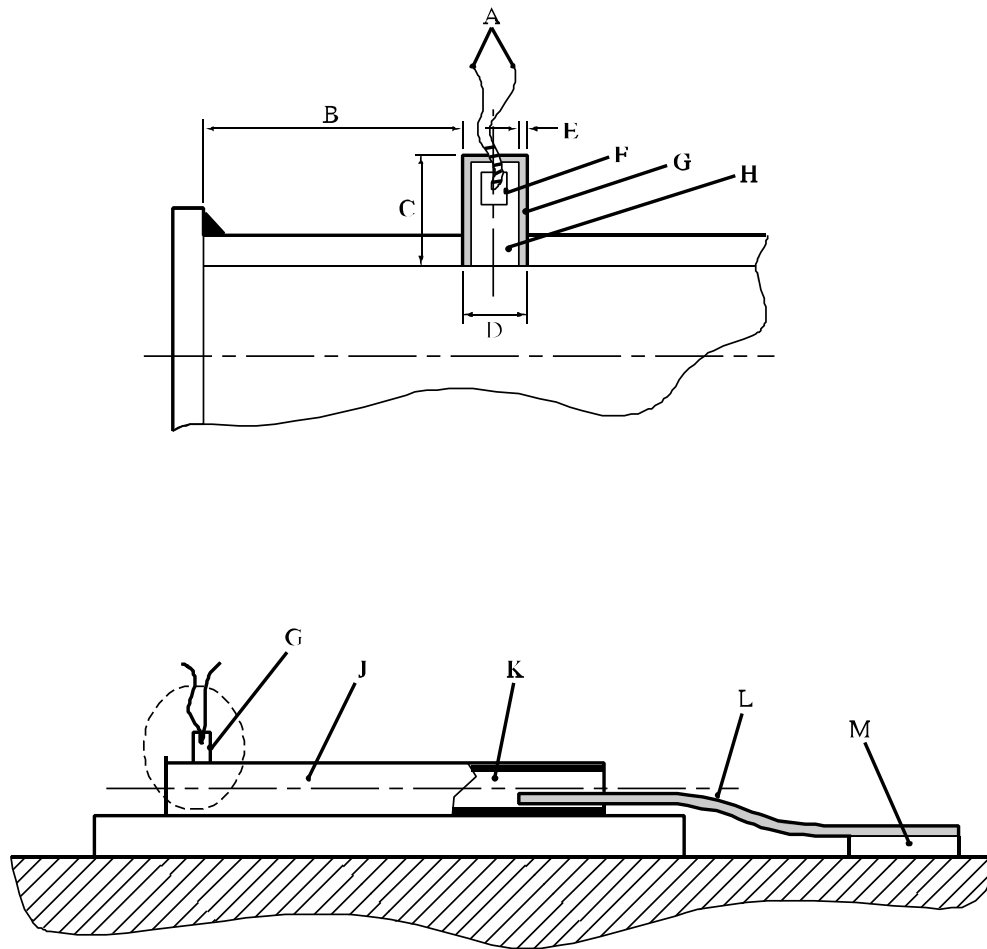
15.5.3.4           *Test criteria and method of assessing results*

Test results are assessed by the tube rupture character or explosion of the detonating cord. The result is considered "+" and the substance should not be classified in Division 1.5 if fragmentation of the tube occurs. The result is considered "-" if no fragmentation of the tube occurs.

15.5.3.5           *Examples of results*

<b>Substance (at 20 °C)</b>	<b>Density (kg/m<sup>3</sup>)</b>	<b>Result</b>
Ammonal (80.5% ammonium nitrate, 15% trotyl, 4.5% aluminium) (powder)	1 000	-
Ammonal No. 1, splitting (66% ammonium nitrate, 24% hexogen, 5% aluminium)	1 100	+
Ammonite 6Zhv (79% ammonium nitrate, 21% trotyl) (powder)	1 000	-
Granulite AS-4 (91.8% ammonium nitrate, 4.2% machine oil, 4% aluminium)	1 000 (1 600)	-
Granulite ASR-8 (70% ammonium nitrate, 4.20% sodium nitrate, 8% aluminium, 2% machine oil)	1 000 (1 600)	-
Ammonium perchlorate	1 100	-
Ammonium perchlorate plus 1.5% of combustible additives	1 100	+





- |  |   |
|--|---|
| (A) Igniter leads                      | (B) Distance of igniter from end of tube (100 mm) |
| (C) Length of igniter (40 mm)          | (D) Outer diameter of igniter (16 mm)             |
| (E) Thickness of igniter casing (1 mm) | (F) Squib   |
| (G) Igniter                            | (H) Black powder                                  |
| (J) Seamless steel tube with the plug  | (K) Test substance                                |
| (L) Detonating cord                    | (M) Aluminium witness plate                       |

**Figure 15.5.3.1: DEFLAGRATION TO DETONATION TRANSITION TEST**

**15.6 Series 5 type (c) test prescription**

**15.6.1 Test 5 (c): External fire test for Division 1.5**

15.6.1.1 *Introduction*

This test is used to determine whether a substance, ~~as packaged~~<sup>as for transport</sup>, can explode if involved in a fire.

15.6.1.2 *Apparatus and materials*

The following items are needed:

- (a) A package (or packages) of explosive substance in the condition and form in which it is offered for ~~transport~~<sup>classification</sup>. The total volume of the package (or packages) to be tested should not be less than 0.15 m<sup>3</sup> and need not exceed 200 kg of net explosive substance;
- (b) A metal grid to support the products above the fuel and allow adequate heating. If a wooden crib fire is used, the grid should be 1.0 m above the ground and if a liquid hydrocarbon pool fire is used then the grid should be 0.5 m above the ground;
- (c) Strapping or wire, if necessary, to hold the packages together on the support grid;
- (d) Enough fuel to keep a fire burning for at least 30 minutes or until the substance has clearly had sufficient time to react to the fire;
- (e) Suitable means of ignition to ignite the fuel on at least two sides e.g. for a wood fire, kerosene to soak the wood and pyrotechnic igniters with wood wool;
- (f) Cine or video cameras, preferably high speed and normal speed, to record events in colour.

15.6.1.3 *Procedure*

15.6.1.3.1 The required number of packages, ~~in the condition and form in which they are offered for transport~~, are arranged as close as possible to one another on the metal grid. If necessary, the packages may be encircled with a steel strip to support them during the test. Fuel is placed beneath the grid so that the fire will engulf the packages. Precautions against side winds may be required to avoid dissipation of the heat. Suitable methods of heating include a wood fire using a lattice of wooden laths, a liquid fuel fire and a propane burner.

15.6.1.3.2 The recommended method is to use a wood fire which has a balanced air/fuel ratio, thereby avoiding too much smoke which would obscure the events, and which burns with sufficient intensity and duration to bring many kinds of packaged explosives to reaction in 10 to 30 minutes. A suitable method involves using air-dried pieces of wood (approximately 50 mm square section), stacked to form a lattice beneath the grid (1 m off the ground), and up to the base of the grid supporting the packages. The wood should extend beyond the packages to a distance of at least 1.0 m in every direction and the lateral distance between the laths should be about 100 mm. Enough fuel should be used to keep the fire burning for at least 30 minutes or until the substance or article has clearly had sufficient time to react to the fire.

15.6.1.3.3 A receptacle filled with suitable liquid fuel, a combination of both wood and liquid fuel or a gas fire may be used as alternatives to the wood fire providing they are as severe. If a liquid pool fire is used, the receptacle should extend beyond the packages to a distance of at least 1.0 m in every direction. The distance between the grid platform and the receptacle should be approximately 0.5 m. Before using this method, consideration should be given to whether any quenching action or adverse interaction between explosives and liquid fuel can occur such as might bring the results into question. If a gas fire is used, the grid should be at the correct height above the burner to allow for adequate fire engulfment.

15.6.1.3.4 The ignition system should be put into place and the fuel ignited on two sides, one the upwind side, simultaneously. The test should not be performed under conditions where the wind speed exceeds 6 m/s. ***A safe waiting period, prescribed by the test agency, should be observed after the fire has extinguished.***

15.6.1.3.5 Observations are made of evidence of explosion such as a loud noise and the projection of fragments from the fire area.

15.6.1.3.6 The test is normally performed once only but if the wood or other fuel used for the fire is all consumed leaving a significant quantity of unconsumed explosive substance in the remains or in the vicinity of the fire, then the test should be performed again using more fuel, or a different method, to increase the intensity and/or duration of the fire. If the result of the test does not enable the hazard division to be determined, a further test should be performed.

15.6.1.4 *Test criteria and method of assessing results*

A substance which explodes in this test is considered to give a "+" result and should not be classified in Division 1.5.

15.6.1.5 *Examples of results*

---

<b>Substance</b>	<b>Result</b>
ANFO	-
ANFO (with 6% aluminium powder)	-
ANFO (with 6% combustible material)	-
ANFO emulsion (with 1% microspheres)	-
ANFO emulsion (with 3.4% microspheres)	-

---



## SECTION 16

## TEST SERIES 6

## 16.1 Introduction

16.1.1 The results from four types of series 6 tests are used to determine which division, amongst Divisions 1.1, 1.2, 1.3 and 1.4, corresponds most closely to the behaviour of a product if ~~a load is~~ involved in a fire resulting from internal or external sources, or an explosion from internal sources (boxes 26, 28, 30, 32 and 33 of Figure 10.3). The results are also necessary to assess whether a product can be assigned to Compatibility Group S of Division 1.4 and whether or not it should be excluded from ~~Class I~~ the class of explosives (boxes 35 and 36 of Figure 10.3). The four types of test are:

- Type 6 (a): a test on a single package to determine if there is mass explosion of the contents;
- Type 6 (b): a test on packages of an explosive substance or explosive articles, or non-packaged explosive articles, to determine whether an explosion is propagated from one package to another or from a non-packaged article to another;
- Type 6 (c): a test on packages of an explosive substance or explosive articles, or non-packaged explosive articles, to determine whether there is a mass explosion or a hazard from dangerous projections, radiant heat and/or violent burning or any other dangerous effect when involved in a fire; and
- Type 6 (d): a test on an unconfined package of explosive articles to which special provision 347 of Chapter 3.3 of the Model Regulations applies, to determine if there are hazardous effects outside the package arising from accidental ignition or initiation of the contents.

## 16.2 Test methods

16.2.1 The test methods currently used are listed in Table 16.1.

**Table 16.1: TEST METHODS FOR TEST SERIES 6**

Test code	Name of Test	Section
6 (a)	Single package test <sup>a</sup>	16.4.1
6 (b)	Stack test <sup>a</sup>	16.5.1
6 (c)	External fire (bonfire) test <sup>a</sup>	16.6.1
6 (d)	Unconfined package test <sup>a</sup>	16.7.1

<sup>a</sup> *Recommended test.*

16.2.2 Test types 6 (a), 6 (b), 6 (c) and 6 (d) are normally performed in alphabetical order. However, it is not always necessary to follow this order or to conduct tests of all types.

- (a) Test type 6 (a) may be waived if explosive articles are ~~carried classified~~ without packaging or when the package contains only one article, (see also section 16.2.2 (d));
- (b) Test type 6 (b) may be waived if in each type 6 (a) test, (see also section 16.2.2 (d));
  - (i) The exterior of the package is undamaged by internal ~~detonation and/or ignition initiation~~; or
  - (ii) The contents of the package fail to explode, or explode so feebly as would exclude propagation of the explosive effect from one package to another in test type 6(b).

- (c) Test type 6 (c) may be waived if, in a type 6 (b) test, there is practically instantaneous explosion of virtually the total contents of the stack. In such cases the product is assigned to Division 1.1;
- (d) Test type 6(d) is a test used to determine whether a 1.4S classification is appropriate and is only used if special provision 347 on Chapter 3.3 of the Model Regulations applies. When testing articles to which special provision 347 applies, test type 6(d) may be performed first. If the results of test type 6(d) indicate that a 1.4S classification is appropriate, then test types 6(a) and 6(b) may be waived.

16.2.3 If a substance gives a "-" result (no propagation of detonation) in the Series 1 type (a) test, the 6(a) test with a detonator may be waived. If a substance gives a "-" result (no or slow deflagration) in a Series 2 type (c) test, the 6 (a) test with an igniter may be waived.

16.2.4 Explanations of certain terms used in the assignment of divisions and compatibility groups are given in the Glossary in Appendix B of the Model Regulations (e.g. mass explosion, pyrotechnic substance, entire load, total contents, explode, explosion of the total contents).

### 16.3 Test conditions

16.3.1 Tests from series 6 should be applied to packages of explosive substances and articles in the condition and form in which they are offered for ~~transport classification~~. The geometrical arrangement of the products should be realistic in regard to the packing method ~~and the conditions of transport~~ and should be such as to produce the most ~~disadvantageous-severe~~ test results. Where explosive articles are to be ~~carried-classified~~ without packaging, the tests should be applied to the non-packaged articles. All types of packaging containing substances or articles should be subjected to the tests unless:

- (a) The product, including any packaging, can be unambiguously assigned to a division by a competent authority on the basis of results from other tests or of available information; or
- (b) The product, including any packaging, is assigned to Division 1.1.

---

**16.4 Series 6 type (a) test prescription**

**16.4.1 Test 6 (a): Single package test**

16.4.1.1 *Introduction*

This is a test on a single package to determine if there is mass explosion of the contents.

16.4.1.2 *Apparatus and materials*

The following items are required:

- (a) A detonator to initiate the substance or article or an igniter just sufficient to ensure ignition of the substance or article (see 16.4.1.3.2 and 16.4.1.3.3);
- (b) Suitable confining materials (see 16.4.1.3.4); and
- (c) A sheet of 3 mm thick mild steel to act as a witness plate.

Blast measuring equipment may be used.

16.4.1.3 *Procedure*

16.4.1.3.1 The test is applied to packages of explosive substances and articles in the condition and form in which they are offered for ~~transport~~classification. Where explosive articles are to be ~~carried~~classified without packaging, the tests should be applied to the non-packaged articles. The decision to use either an initiating stimulus or an igniting stimulus is based on the following considerations.

16.4.1.3.2 For packaged substances:

- (a) If the substance is intended to function by detonation, it should be tested with a standard detonator (Appendix 1);
- (b) If the substance is intended to function by deflagration, it should be tested with an igniter just sufficient (but not more than 30 g of black powder) to ensure ignition of the substance within the package. The igniter should be located in the center of the substance in the package;
- (c) Substances not intended for use as explosive, but provisionally accepted into the class of explosives~~Class 1~~, should be tested first with a standard detonator (Appendix 1) and, if no explosion occurs, with an igniter as in (b) above. If a substance gives a "-" result (no propagation of detonation) in the Series 1 type (a) test, the test with a detonator may be waived and if a substance gives a "-" result (no or slow deflagration) in a Series 2 type (c) test, the test with an igniter may be waived.

16.4.1.3.3 For packaged articles<sup>1</sup>:

- (a) Articles provided with their own means of initiation or ignition:

The functioning of an article near the centre of the package is stimulated by the article's own means of initiation or ignition. Where this is impracticable, the article's own means of initiation or ignition is replaced by another form of stimulus having the required effect;

- (b) Articles not provided with their own means of initiation or ignition:

---

<sup>1</sup> Subject to the proviso that in the case of articles containing a very small quantity of substance(s) of compatibility group A only, a sufficient number of such items should be initiated simultaneously to cause not less than 0.2 g of primary explosive to explode.

- (i) An article near the centre of the package is caused to function in the designed mode; or
- (ii) An article near the centre of the package is replaced by another article which can be caused to function with the same effect.

16.4.1.3.4 The package is placed on a steel witness plate on the ground. The preferred method of confinement consists of containers, similar in shape and size to the test package, completely filled with earth or sand and placed as closely as possible around the test package to a minimum thickness of confinement, in every direction of 0.5 m for a package not exceeding 0.15 m<sup>3</sup> and 1.0 m for a package greater than 0.15 m<sup>3</sup>. Alternative methods of confinement are to use boxes or bags filled with earth or sand placed around and on top of the package or to use loose sand.

16.4.1.3.5 The substance or article should be initiated and observations made on the following: evidence of thermal effects, projection effects, detonation, deflagration or explosion of the total contents of the package. **A safe waiting period, prescribed by the test agency, should be observed after initiation.** The test should be performed three times unless a decisive result occurs earlier (e.g. explosion of the total contents). ~~If the results of the recommended number of tests do not enable unambiguous interpretation of the results, the number of tests should be increased.~~

16.4.1.4 *Test criteria and method of assessing results*

Mass explosion (~~see definition in Chapter 2.1 of the Model Regulations~~) indicates a candidate for Division 1.1. Evidence of such an indication includes:

- (a) A crater at the test site;
- (b) Damage to the witness plate beneath the package;
- (c) Measurement of a blast; and
- (d) Disruption and scattering of the confining material.

If the product is accepted into Division 1.1, further testing is not necessary; otherwise proceed to a test of type 6 (b).

16.4.1.5 *Examples of results*

Substance	Packaging	Initiation system	Events	Result
Ammonium perchlorate (12 µm)	10 kg fibreboard drum	Detonator	Detonation	Candidate Division 1.1
Musk xylene	50 kg fibreboard drum	Detonator	Localised decomposition	Not Division 1.1
Musk xylene	50 kg fibreboard drum	Igniter	Localised decomposition	Not Division 1.1
Single base propellant (non-porous)	60 litre fibreboard drum	Igniter	No explosion	Not Division 1.1
Single base propellant (porous)	60 litre fibreboard drum	Igniter	Explosion	Candidate Division 1.1



**16.5 Series 6 type (b) test prescription**

**16.5.1 Test 6 (b): Stack test**

16.5.1.1 *Introduction*

This is a test on packages of an explosive substance or explosive articles, or unpackaged explosive articles, to determine whether an explosion is propagated from one package to another or from a unpackaged article to another.

16.5.1.2 *Apparatus and materials*

The following items are required:

- (a) A detonator to initiate the substance or article or an igniter just sufficient to ensure ignition of the substance or article (see 16.5.1.4 and 16.5.1.5);
- (b) Suitable confining materials (see 16.5.1.3); and
- (c) A sheet of 3 mm thick mild steel to act as a witness plate.

Blast measuring equipment may be used.

16.5.1.3 *Procedure*

The test is applied to a stack of packages of an explosive product or a stack of unpackaged articles, in each case, in the condition and form in which they are offered for [transport classification](#). Where explosive articles are to be [carried-classified](#) without packaging, the tests should be applied to the unpackaged articles. Sufficient packages or articles to give a total volume of 0.15 m<sup>3</sup> are stacked on a steel witness plate on the ground. If the volume of an individual package (or unpackaged article) exceeds 0.15 m<sup>3</sup>, then the test is performed with at least one acceptor placed in the position most likely to result in communication between the individual products (see 16.3.1). If this position is not known, several acceptors are used. The preferred method of confinement consists of containers, similar in shape and size to the test packages completely filled with earth or sand and placed as closely as possible around the test package to create a minimum thickness of confinement, in every direction, of 1 m. Alternative methods of confinement are to use boxes or bags filled with earth or sand placed around and on top of the stack or to use loose sand. If loose sand is used for confinement, the stack should be covered or protected to ensure that no sand falls into the interstices between adjacent packages or non-packaged articles. Articles [carried-classified](#) without packaging are confined in a manner analogous to that used for packaged articles. The decision to use either an initiating stimulus or an igniting stimulus is based on the following considerations.

16.5.1.4 For packaged substances:

- (a) If the substance is intended to function by detonation, it should be tested with a standard detonator (Appendix 1);
- (b) If the substance is intended to function by deflagration, it should be tested with an igniter just sufficient (but not more than 30 g of black powder) to ensure ignition of the substance within one individual package. The igniter should be located in the centre of the substance in the package;
- (c) Substances not intended for use as explosives, but provisionally accepted into [Class 4 the class of explosives](#), should be tested using whichever initiation system gave a "+" result in a type 6 (a) test.

16.5.1.5 For packaged articles and unpackaged articles<sup>2</sup>:

- (a) Articles provided with their own means of initiation or ignition.

The functioning of an article at the centre of the package near the centre of the stack should be stimulated by the article's own means of initiation or ignition. Where this is impracticable, the article's own means of initiation or ignition may be replaced by another form of stimulus having the required effect;

- (b) Articles not provided with their own means of initiation or ignition:

- (i) An article at the centre of the package near the centre of the stack is caused to function in the designed mode; or
- (ii) An article at the centre of the package near the centre of the stack is replaced by another article which can be caused to function with the same effect.

16.5.1.6 The point of ignition or initiation should be situated in a package near the centre of the stack. Articles ~~carried-classified~~ without packaging are tested in a manner analogous to that used for packaged articles.

16.5.1.7 The substance or article should be initiated and observations made on the following: evidence of thermal effects, projection effects, detonation, deflagration or explosion of the total contents of the package. ***A safe waiting period, prescribed by the test agency, should be observed after initiation.*** The test should be performed three times unless a decisive result occurs earlier (i.e. explosion of the total contents). If the results of the recommended number of tests do not enable unambiguous interpretation of the results, the number of tests should be increased.

16.5.1.8 *Test criteria and method of assessing results*

If in test 6 (b) explosion of the contents of more than one package or unpackaged article occurs practically instantaneously, then the product is assigned to Division 1.1. Evidence of such an occurrence includes:

- (a) A crater at the test site appreciably larger than that given by a single package or unpackaged article;
- (b) Damage to the witness plate beneath the stack which is appreciably greater than that from a single package or unpackaged article;
- (c) Measurement of blast which significantly exceeds that from a single package or unpackaged article; and
- (d) Violent disruption and scattering of most of the confining material.

Otherwise proceed to a test of type 6 (c).

16.5.1.9 *Examples of results*

No examples of results are given as these are too specific to the packaging or article tested.

---

<sup>2</sup> Subject to the proviso that in the case of articles containing a very small quantity of substance(s) of compatibility group A only, a sufficient number of such items are initiated simultaneously to cause not less than 0.2 g of primary explosive to explode.

**16.6 Series 6 type (c) test prescription**

**16.6.1 Test 6 (c): External fire (bonfire) test**

16.6.1.1 *Introduction*

This is a test performed on packages of an explosive substance or explosive articles, or unpackaged explosive articles, to determine whether there is a mass explosion or a hazard from dangerous projections, radiant heat and/or violent burning when involved in a fire.

16.6.1.2 *Apparatus and materials*

The following items are needed:

- (a) If the volume of the package of substance or articles, or unpackaged article, is less than 0.05 m<sup>3</sup>, sufficient packages or unpackaged articles to give a total volume of not less than 0.15 m<sup>3</sup>;
- (b) If the volume of the package of substance or articles, or unpackaged article, is equal to or greater than 0.05 m<sup>3</sup>, three packages or unpackaged articles. If the volume of one package or unpackaged article is greater than 0.15 m<sup>3</sup>, the competent authority may waive the requirement for three packages or unpackaged articles to be tested;
- (c) A metal grid to support the products above the fuel and allow adequate heating. If a wooden crib fire is used, the grid should be 1.0 m above the ground and if a liquid hydrocarbon pool fire is used then the grid should be 0.5 m above the fuel surface at the onset of the test;
- (d) Strapping or wire, if necessary, to hold the packages or unpackaged articles together on the support grid;
- (e) Enough fuel to keep a fire burning for at least 30 minutes or, if necessary, until the substance or article has clearly had sufficient time to react to the fire (see 16.6.1.3.8);
- (f) Suitable means of ignition to ignite the fuel on at least two sides e.g. for a wood fire, kerosene to soak the wood and pyrotechnic igniters with wood wool;
- (g) Three 2 000 mm × 2 000 mm × 2 mm 1100-0 aluminium sheets (Brinell Hardness 23, tensile strength 90 MPa), or equivalent, to act as witness screens together with suitable supports to hold them vertically. The witness screens shall be mounted rigidly to their frames. When more than one panel is used to make a witness screen, each panel shall be supported at all joints;
- (h) Video equipment capable of recording the events necessary for classification. The type, number and placement of the camera(s) shall be sufficient to record all events to be assessed.

Blast gauges, radiometers and associated recording equipment may also be used. Further equipment may be needed when following the procedure in 16.6.1.3.9.

16.6.1.3 *Procedure*

16.6.1.3.1 The required number of packages or unpackaged articles, ~~in the condition and form in which they are offered for transport~~, are arranged as close as possible to one another on the metal grid. If directional effects are anticipated, packages or unpackaged articles should be oriented in such a way to maximize probability for projections to hit witness screens and for discrete flame jets to be pointed horizontally. If necessary, the packages or unpackaged articles may be encircled with a steel strip to support them during the test. Fuel is placed beneath the grid so that the fire will engulf the packages or unpackaged articles. Suitable methods of heating include a wood, liquid or gas fuel fire or a combination thereof, which achieves a temperature of 800 °C. Fluctuations of temperature below 800 °C are normal and should not render the test invalid.

16.6.1.3.2 A wood fire should burn the packages or unpackaged articles with sufficient intensity and duration to completely react the explosives (see 16.6.1.2(e)). Dried pallets, boards, laths, or other wood alone or in combination may be stacked to form a lattice beneath the grid 1 m off the ground, and up to the base of the grid supporting the packages or unpackaged articles. The wood should extend at least 1 m beyond the packages or unpackaged articles to ensure that the fire engulfs the product.

16.6.1.3.3 A receptacle filled with suitable liquid fuel, a combination of both wood and liquid fuel fire may be used as an alternative to the wood fire providing it is as severe. If a liquid pool fire is used, the receptacle should extend beyond the packages or unpackaged articles to a distance of at least 1.0 m in every direction. The distance between the grid platform and the receptacle should be approximately 0.5 m. Before using this method, consideration should be given to whether any quenching action or adverse interaction between explosives and liquid fuel can occur such as might bring the results into question.

16.6.1.3.4 If gas is to be used as a fuel, the burning area must extend beyond the packages or unpackaged articles to a distance of at least 1.0 m in every direction. The gas must be supplied in such a manner to ensure that the fire is evenly distributed around the packages. The gas reservoir should be large enough to keep the fire burning for at least 30 minutes. Ignition of the gas may be accomplished either by remotely ignited pyrotechnics or by remote release of the gas adjacent to a pre-existing source of ignition.

16.6.1.3.5 The witness screens are erected vertically in each of three quadrants at a distance of 4 m from the edge of the packages or unpackaged articles. The sheets should be placed so that the centres are approximately level with the centre of the packages or unpackaged articles or, if this is less than 1.0 m above the ground, in contact with the ground. If there are any perforations or indentations in the witness screens before the test, they should be marked so that they can be clearly distinguished from those created during the test.

16.6.1.3.6 The ignition system should be put into place and the fuel ignited on two sides, one the upwind side, simultaneously. The test should not be performed under conditions where the wind speed exceeds 6 m/s. ***A safe waiting period, prescribed by the test agency, should be observed before approaching the test area.***

16.6.1.3.7 Observations are made on the following:

- (a) Evidence of explosion;
- (b) Potentially hazardous projections; and
- (c) Thermal effects.

16.6.1.3.8 The test is normally performed once only but if the wood or other fuel used for the fire is all consumed leaving a significant quantity of unconsumed explosive substance in the remains or in the vicinity of the fire, then the test should be performed again using more fuel, or a different method, to increase the intensity and/or duration of the fire. If the result of the test does not enable the hazard division to be determined, a further test should be performed.

16.6.1.3.9 For candidates to cartridges, small arms ([Division 1.4, Compatibility Group S in transport](#), UN No. 0012), this test can be augmented or replaced by the specialised measurement of the energy of projections as described in Appendix 9. This applies to circumstances where the dominant hazard is a projection hazard, for example as known from previous testing of similar explosive articles.

16.6.1.4 *Test criteria and method of assessing results*

16.6.1.4.1 The following criteria are used to answer the questions in Figure 10.3 (boxes 26, 28, 30, 32, 33, 35 and 36) in order to assess the results and classify the product.

16.6.1.4.2 If mass explosion occurs then the product is assigned to Division 1.1. A mass explosion is considered to occur if a substantial proportion explodes so that the practical hazard should be assessed by assuming simultaneous explosion of the whole of the explosive content of the packages or unpackaged articles.

16.6.1.4.3 If a mass explosion does not occur but any one of the following occurs:

- (a) A perforation of any of the witness screens (see 16.6.1.3.5);

- (b) A metallic projection with a kinetic energy exceeding 20 J as assessed by the distance - mass relation given in Figure 16.6.1.1;

then the product is assigned to Division 1.2.

16.6.1.4.4 If none of the events occur which would require the product to be assigned to Division 1.1 or 1.2 but any one of the following events occurs:

- (a) a fireball or jet of flame which extends beyond any of the witness screens;
- (b) a fiery projection emanating from the product is thrown more than 15 m from the edge of the packages or unpackaged articles;
- (c) a burning time of the product measured to be less than 35 seconds for 100 kg net explosive mass (see 16.6.1.4.8 Notes for scaling time measurements in evaluating thermal flux effects). Alternatively, in the case of articles and low energy substances, the irradiance of the burning product exceeds that of the fire by more than 4 kW/m<sup>2</sup> at a distance of 15 m from the edge of the packages or unpackaged articles. The irradiance is measured over 5 seconds, during the period of maximum output;

then the product is assigned to Division 1.3.

16.6.1.4.5 If none of the events occur which would require the product to be assigned to Division 1.1, 1.2 or 1.3, but any one of the following events occurs:

- (a) a fireball or jet of flame which extends more than 1 m from the flames of the fire;
- (b) a fiery projection emanating from the product is thrown more than 5 m from the edge of the packages or unpackaged articles;
- (c) an indentation in any of the witness screens of more than 4 mm;
- (d) a metallic projection with a kinetic energy exceeding 8 J as assessed by the distance - mass relation given in Figure 16.6.1.1;
- (e) a burning time of the product measured to be less than 330 seconds for 100 kg net explosive mass (see 16.6.1.4.8: Notes for scaling time measurements in evaluating thermal flux effects);

then the product is assigned to Division 1.4 and to a compatibility group other than Compatibility Group S.

16.6.1.4.6 If none of the events occur which would require the product to be assigned to Division 1.1, 1.2, 1.3 or 1.4 other than Compatibility Group S (see Box 32 of Figure 10.3), then the product is assigned to Division 1.4 Compatibility Group S, unless special provision 347 of Chapter 3.3 of the Model Regulations applies. For candidates to Cartridges, small arms ([Division 1.4, Compatibility Group S in transport](#), UN No. 0012), evidence of projections with a kinetic energy not exceeding 8 J as determined by the test procedure in Appendix 9 may be used to assign the product to Compatibility Group S.

16.6.1.4.7 If there are no hazardous effects at all, the product is considered for exclusion from Class 1. The possibilities, as shown by boxes 35 and 36 in Figure 10.3, are:

- (a) If the product is an article manufactured with a view to producing a practical explosive or pyrotechnic effect, then:
  - (i) If there is some effect (projection, fire, smoke, heat or loud noise) external to the device itself, the device is not excluded from Class 1 and the product, as packaged, is assigned to Division 1.4 and to Compatibility Group S. Paragraph 2.1.1.1 (b) of the Model Regulations refers explicitly to the device, rather than the package, so it is usually necessary to make this assessment on the basis of a test involving functioning of the device without packaging or confinement. Sometimes the stated effects are observed in test 6 (c), in which case the product is classified 1.4 S without further tests;
  - (ii) If there is no effect (projection, fire, smoke, heat or loud noise) external to the device itself, the unpackaged device is excluded from Class 1 in accordance with paragraph 2.1.1.1 (b) of the Model Regulations. Paragraph 2.1.1.1 (b) of the Model Regulations refers explicitly to the device, rather than the package, so it is usually necessary to make this assessment on the basis of a test involving functioning of the device without packaging or confinement;
- (b) If the product is not manufactured with a view to producing a practical explosive or pyrotechnic effect, it is excluded from Class 1 in accordance with paragraph 2.1.1.1 of the Model Regulations.

16.6.1.4.8 Notes for scaling time measurements in evaluating thermal flux effects

**Notes:**

(1) The value of 35 seconds/100 kg (see 16.6.1.4.4 (c)) correlates to an average thermal flux of 4 kW/m<sup>2</sup> at 15 m and is based on an assumed heat of combustion of 12 500 J/g. If the true heat of combustion is significantly different, the burning time of 35 s may be corrected; for example, a true heat of combustion of 8 372 J/g burning for  $(8\,372/12\,500) \times 35\text{ s} = 23.4\text{ s}$  would produce the same flux level. Corrections for masses other than 100 kg are made according to the scaling relations and examples in Table 16.2.

(2) The value of 330 seconds/100 kg (see 16.6.1.4.5(e)) correlates to an average thermal flux of 4 kW/m<sup>2</sup> at 5 m and is based on an assumed heat of combustion of 12 500 J/g. If the true heat of combustion is significantly different, the burning time of 330 s may be corrected; for example, a true heat of combustion of 8 372 J/g burning for  $(8\,372/12\,500) \times 330\text{ s} = 221\text{ s}$  would produce the same flux level. Corrections for masses other than 100 kg are made according to the scaling relations and examples in Table 16.2.

(3) In some burn time trials, individual packages or articles will be observed to burn in separate, identifiable events; in such cases, the burning times and masses of each separate event should be used.

**Table 16.2: COMPARATIVE THERMAL FLUX VALUES FOR VARYING MASSES**

Mass (kg)	1.3/1.4		1.4/1.4S	
	Flux (15 m)	Burn time (s)	Flux (5 m)	Burn time (s)
20	1.36 kW/m <sup>2</sup>	21.7	1.36 kW/m <sup>2</sup>	195
50	2.5	29.6	2.5	266
100	4	35	4	330
200	6.3	46.3	6.3	419
500	11.7	63.3	11.7	569

*NOTE: Thermal flux is scaled on basis of  $(m/m_0)^{2/3}$ .  
Times are scaled on basis of  $(m/m_0)^{1/3}$ .*

The values of thermal flux can be calculated from the equation:

$$F = \frac{C \times E}{4\pi R^2 t}$$

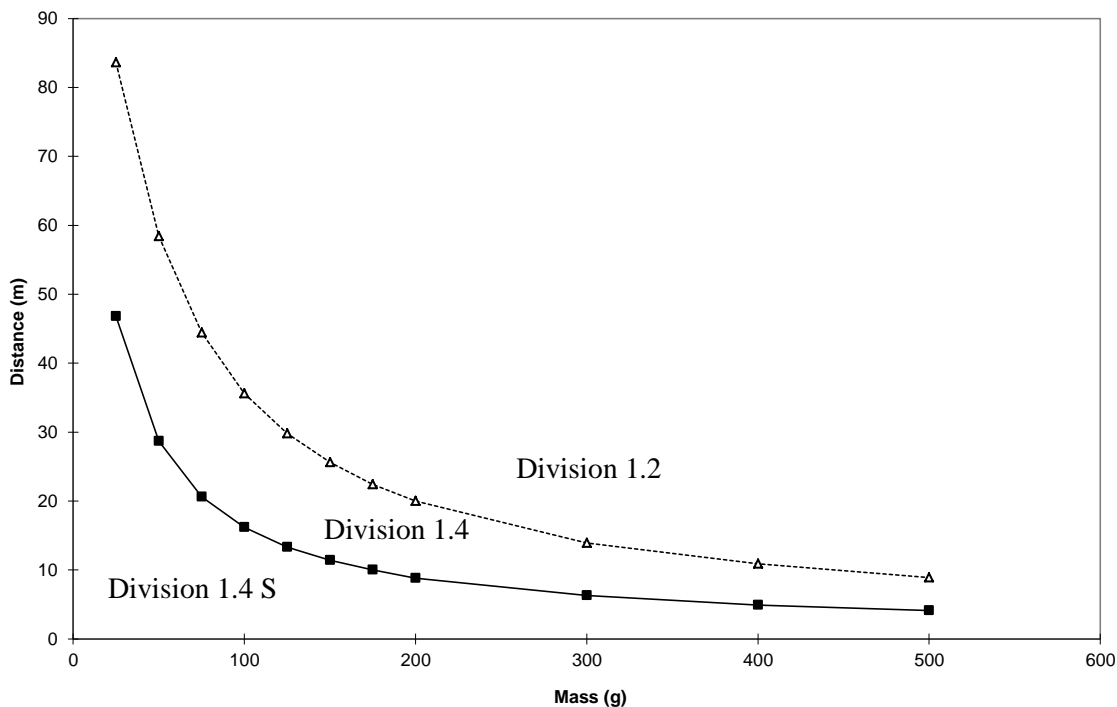
where:

- F = thermal flux in kW/m<sup>2</sup>;
- C = constant = 0.33;
- E = total energy content in joules;
- R = distance from fire to exposed position in meters;
- T = observed burn time in seconds.

#### 16.6.1.5 Examples of results

Substance	Packaging	Events	Result
Musk xylene	3 × 50 kg fibreboard drums	Slow burning only	Not Class 1

Distance - Mass relation



Mass (g)	Projection distance (m)	
	20 J	8 J
25	83.6	46.8
50	58.4	28.7
75	44.4	20.6
100	35.6	16.2
125	29.8	13.3
150	25.6	11.4
175	22.43	10
200	20	8.8
300	13.9	6.3
400	10.9	4.9
500	8.9	4.1

Example data for metallic projections with a kinetic energy of 20 J and 8 J

**FIGURE 16.6.1.1: DISTANCE-MASS RELATION FOR METALLIC PROJECTIONS WITH A KINETIC ENERGY OF 20 J AND 8 J<sup>3</sup>**

<sup>3</sup> The data presented in Figure 16.6.1.1 is based upon metallic projections. Non-metallic projections will produce different results and may be hazardous. Hazards from non-metallic projections should also be considered.



---

**16.7 Series 6 type (d) test prescription**

**16.7.1 Test 6 (d): Unconfined package test**

16.7.1.1 *Introduction*

This is a test on a single package to determine if there are hazardous effects outside the package arising from accidental ignition or initiation of the contents.

16.7.1.2 *Apparatus and materials*

The following items are required:

- (a) A detonator to initiate the article or an igniter just sufficient to ensure ignition of the substance or article (see 16.7.1.3.2); and
- (b) A sheet of 3 mm thick mild steel to act as a witness plate.

Video equipment may be used.

16.7.1.3 *Procedure*

16.7.1.3.1 The test is applied to packages of explosive articles in the condition and form in which they are offered for ~~transport~~classification. Where explosive articles are ~~to be carried~~classified without packaging, the tests should be applied to the non-packaged articles. The decision to use either an initiating stimulus or an igniting stimulus is based on the following considerations.

16.7.1.3.2 For packaged articles:

- (a) Articles provided with their own means of initiation or ignition:

The functioning of an article near the centre of the package is stimulated by the article's own means of initiation or ignition. Where this is impracticable, the article's own means of initiation or ignition is replaced by another form of stimulus having the required effect;

- (b) Articles not provided with their own means of initiation or ignition:

- (i) an article near the centre of the package is caused to function in the designed mode; or
- (ii) an article near the centre of the package is replaced by another article which can be caused to function with the same effect.

16.7.1.3.3 The package is placed on a steel witness plate on the ground without confinement.

16.7.1.3.4 The donor article should be initiated and observations made on the following: denting or perforation of the witness plate beneath the package, a flash or flame capable of igniting an adjacent material, disruption of the package causing projection of the explosives contents; or full perforation of the packaging by a projection. **A safe waiting period, prescribed by the test agency, should be observed after initiation.** The test should be performed three times, in different orientations, unless a decisive result is observed earlier. If the results of the recommended number of tests do not enable unambiguous interpretation of the results, the number of tests should be increased.

16.7.1.4 *Test criteria and method of assessing the results*

Inclusion in Compatibility Group S requires that any hazardous effects arising from functioning of the articles in this test are confined within the package. Evidence of a hazardous effect outside the package includes:

- (a) Denting or perforation of the witness plate beneath the package;

- (b) A flash or flame that ignites an adjacent material such as a sheet of  $80 \pm 3-10$  g/m<sup>2</sup> paper at a distance of 25 cm from the package;—

*(Note by the secretariat: Correction to the 6th revised edition. Refer to ST/SG/AC.10/11/Rev.6/Corr.1)*

- (c) Disruption of the package causing projection of the explosives contents; or
- (d) A projection which passes completely through the packaging (a projection or fragment retained or stuck in the wall of the packaging is considered as non hazardous).

The competent authority may wish to take into account the expected effect of the initiator when assessing the results of the test, if these are expected to be significant when compared to the articles being tested. If there are hazardous effects outside the package, then the product is excluded from Compatibility Group S.

16.7.1.5 *Examples of results*

Article	Packaging	Initiation system	Events	Result
Cartridges, power device	Fibreboard box containing 20 articles (300 g of propellant each) each in a plastic bag	One of the articles	Articles ignited one by one, producing flames up to 2 m high outside package	Not consistent with Compatibility Group S
Detonator assemblies, non-electric	Fibreboard box containing 60 assemblies each in a plastic bag with its shock tube coiled in a figure 8, with attenuators on the detonators	One of the articles	One out of 60 detonators fired and no visible effects outside the box.	Consistent with Compatibility Group S
Detonators, electric	Fibreboard box containing 84 assemblies, each bundled with its wire so that the blast from a firing detonator would be attenuated	One of the articles	One out of 84 detonators fired. The reaction caused the box to break open and released some of the assemblies but it was judged that there were no hazardous effects outside the package.	Consistent with Compatibility Group S
Charges, shaped (open-face 19 g perforators)	Fibreboard box containing 50 charges in two layers so that pairs of charges were focused toward each other	Detonator with approximately 60 mm of detonating cord	Three trials were conducted. In each of the trials, the witness plate was perforated with three to four charges reacting. The packages were blown apart scattering the remaining charges over a wide area.	Not consistent with Compatibility Group S
Detonators, electric	Fibreboard box containing 50 detonators each with a 450 mm lead wire. Each assembly was contained in its own fibreboard inner box. The boxes were separated by fibreboard panels	One of the articles	One out of 50 detonators fired causing one of the box flaps to open. There were no hazardous effects outside of the package.	Consistent with Compatibility Group S

---

## SECTION 17

### TEST SERIES 7

#### 17.1 Introduction

The question "Is it an extremely insensitive explosive article?" (box 40 of Figure 10.3) is answered by series 7 tests and any candidate for Division 1.6 should pass one of each of the eleven types of test comprising the series. The first six types of test (7(a) to 7(f)) are used to establish if a substance is an Extremely Insensitive Substance (EIS) and the remaining five types of test (7 (g), 7 (h), 7 (j), 7(k) and 7(l)) are used to determine if an article containing an EIS(s) may be assigned to Division 1.6. The eleven test types are:

- Type 7 (a): a shock test to determine sensitivity to intense mechanical stimulus;
- Type 7 (b): a shock test with a defined booster and confinement to determine sensitivity to shock;
- Type 7 (c): a test to determine the sensitivity of the explosive substance to deterioration under the effect of an impact;
- Type 7 (d): a test to determine the degree of reaction of the explosive substance to impact or penetration resulting from a given energy source;
- Type 7 (e): a test to determine the reaction of the explosive substance to an external fire when the material is confined;
- Type 7 (f): a test to determine the reaction of the explosive substance in an environment in which the temperature is gradually increased to 365 °C;
- Type 7 (g): a test to determine the reaction to an external fire of an article which is in the condition as presented for [transport classification](#);
- Type 7 (h): a test to determine the reaction of an article in an environment in which the temperature is gradually increased to 365 °C;
- Type 7 (j): a test to determine the reaction of an article to impact or penetration resulting from a given energy source;
- Type 7 (k): a test to determine whether a detonation of an article will initiate a detonation in an adjacent, like article; and
- Type 7 (l): a test to determine the sensitivity of the article to shock directed at vulnerable components.

The question in box 40 is answered "no" if a "+" result is obtained in any series 7 test.

#### 17.2 Test methods

The test methods currently used are listed in Table 17.1.

**Table 17.1: TEST METHODS FOR TEST SERIES 7**

Test code	Name of Test	Section
<i>Tests on substances</i>		
7 (a)	EIS cap test <sup>a</sup>	17.4.1
7 (b)	EIS gap test <sup>a</sup>	17.5.1
7 (c) (i)	Susan test	17.6.1
7 (c) (ii)	Friability test <sup>a</sup>	17.6.2
7 (d) (i)	EIS bullet impact test <sup>a</sup>	17.7.1
7 (d) (ii)	Friability test	17.7.2
7 (e)	EIS external fire test <sup>a</sup>	17.8.1
7 (f)	EIS slow cook-off test <sup>a</sup>	17.9.1
<i>Tests on articles</i>		
7 (g)	1.6 article external fire test <sup>a</sup>	17.10.1
7 (h)	1.6 article slow cook-off test <sup>a</sup>	17.11.1
7 (j)	1.6 article bullet impact test <sup>a</sup>	17.12.1
7 (k)	1.6 article stack test <sup>a</sup>	17.13.2
7(l)	1.6 article fragment impact test	17.14.1

<sup>a</sup> *Recommended test.*

### 17.3 Test conditions

17.3.1 All explosive components must always be present in articles during Series 7 testing of types 7 (g) to 7 (l). Smaller explosive components containing substances not subjected to tests of type 7 (a) to 7 (f) shall be specifically targeted in tests 7 (j) and 7 (l) when it is assessed that they will cause the most severe reaction from the test article, to ensure the probability of accidental initiation or propagation of a Division 1.6 article remains negligible.

17.3.2 A substance intended for use as a main explosive load in an article of Division 1.6 should be tested in accordance with Test Series 3 and 7. A substance intended for use as a larger (dimensionally) boosting component in an article of Division 1.6, where the volumetric size limit relative to the main explosive load it is boosting is met, should be tested in accordance with Test Series 3 and tests of type 7 (c) (ii) and 7 (e). Test Series 7 should be conducted on the substance in the form (i.e. composition, granulation, density etc.) in which it is to be used in the article.

17.3.3 An article being considered for inclusion in Division 1.6 should not undergo Series 7 testing until after main explosive load and certain boosting component substances have undergone appropriate tests of type 7 (a) to 7 (f) to determine whether they meet the substance requirements for Division 1.6. Guidance on substance testing determination process is given under section 10.4.3.6.

17.3.4 Tests of types 7 (g), 7 (h), 7 (j), 7 (k) and 7 (l) should be performed to determine if an article with an EIS main load(s) and appropriately insensitive boosting components may be assigned to Division 1.6. These tests are applied to articles in the condition and form in which they are offered for [transport classification](#), except that non-explosive components may be omitted or simulated if the competent authority is satisfied that this does not invalidate the results of the tests.

17.3.5 Response levels referred to within the following individual Test Series 7 test prescriptions are provided at Appendix 8 (Response descriptors), to aid in the assessment of the results of tests of types 7 (g), 7 (h), 7 (j), 7 (k) and 7 (l) and should be reported to the competent authority to support assignment to Division 1.6.

---

**17.4**            **Series 7 type (a) test prescription**

**17.4.1**            *Test 7 (a): EIS cap test*

17.4.1.1          *Introduction*

This shock test is designed to determine the sensitivity of an EIS candidate to intense mechanical stimulus.

17.4.1.2          *Apparatus and materials*

The experimental set-up for this test is the same as for test 5 (a) (see 15.4.1).

17.4.1.3          *Procedure*

The experimental procedure is the same as for test 5 (a) (see 15.4.1).

17.4.1.4          *Test criteria and method of assessing results*

The result is considered "+" and the substance should not be classified as an EIS if in any trial:

- (a)    The witness plate is torn or otherwise penetrated (i.e. light is visible through the plate) - bulges, cracks or folds in the witness plate do not indicate cap sensitivity; or
- (b)    The centre of the lead cylinder is compressed from its initial length by an amount of 3.2 mm or more.

Otherwise, the result is considered "-".

17.4.1.5          *Examples of results*

---

<b>Substance</b>	<b>Result</b>
HMX/inert binder (86/14), cast	-
HMX/energetic binder (80/20), cast	+
HMX/aluminium/energetic binder (51/19/14), cast	-
RDX/TNT (60/40), cast	+
TATB/Kel-F (95/5), pressed	-

---

**17.5 Series 7 type (b) test prescription**

**17.5.1 Test 7 (b): EIS gap test**

17.5.1.1 *Introduction*

This test is used to measure the sensitivity of an EIS candidate to a specified shock level, i.e. a specified donor charge and gap.

17.5.1.2 *Apparatus and materials*

The set-up for this test consists of an explosive charge (donor), a barrier (gap), a container holding the test charge (acceptor), and a steel witness plate (target).

The following materials are to be used:

- (a) United Nations Standard detonator or equivalent;
- (b) 95 mm diameter by 95 mm long pellet with a density of  $1\ 600\ \text{kg/m}^3 \pm 50\ \text{kg/m}^3$  of either 50/50 pentolite or 95/5 RDX/WAX;
- (c) Tubing, steel, seamless, with an outer diameter of  $95 \pm 7.0$  mm, a wall thickness of  $9.75\ \text{mm} \pm 2.75$  mm and an inner diameter of  $73.0\ \text{mm} \pm 7.0$  mm and with a length of 280 mm;
- (d) Sample substances, machined to a diameter which is just under the diameter of the steel tubing. The air gap between the sample and tubing wall should be as small as possible;
- (e) Polymethyl methacrylate (PMMA) rod, of 95 mm diameter by 70 mm long;
- (f) Mild steel plate, 200 mm × 200 mm × 20 mm;
- (g) Wood block, 95 mm diameter and 25 mm thick, with a hole drilled through the centre to hold the detonator.

17.5.1.3 *Procedure*

17.5.1.3.1 As shown in Figure 17.5.1.1, the detonator, donor, gap and acceptor charge are coaxially aligned above the centre of the witness plate. A 1.6 mm air gap is maintained between the free end of the acceptor charge and the witness plate with suitable spacers which do not overlap the acceptor charge. Care should be taken to ensure good contact between the detonator and donor, donor and gap and gap and acceptor charge. The test sample and booster should be at ambient temperature for the test.

17.5.1.3.2 To assist in collecting the remains of the witness plate, the whole assembly may be mounted over a container of water with at least a 10 cm air gap between the surface of the water and the bottom surface of the witness plate which should be supported along two edges only.

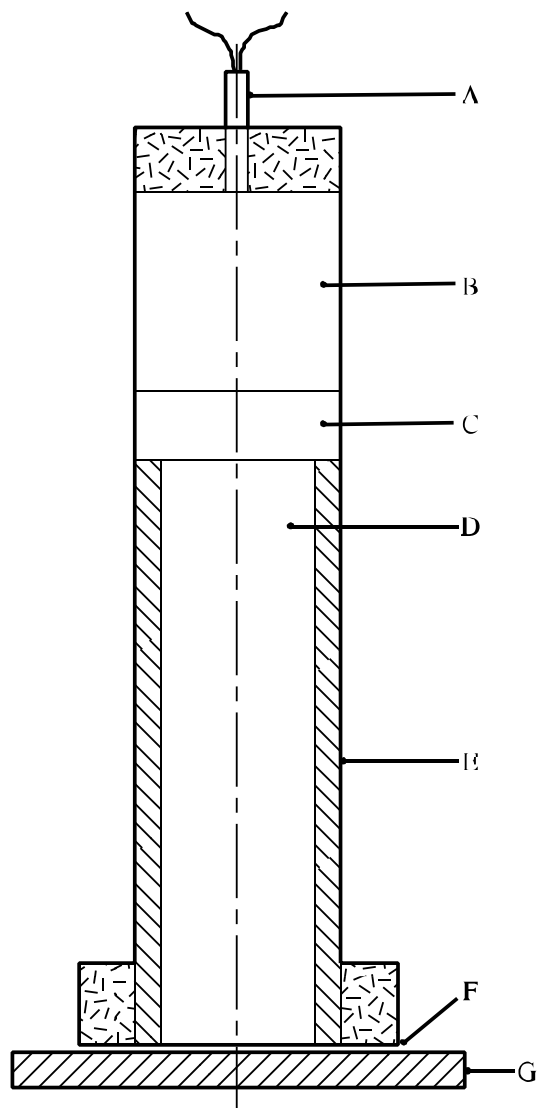
17.5.1.3.3 Alternative collection methods may be used but it is important to allow sufficient free space below the witness plate so as not to impede plate puncture. The test is performed three times unless a positive result is observed earlier.

17.5.1.4 *Test criteria and method of assessing results*

A clean hole punched through the plate indicates that a detonation was initiated in the sample. A substance which detonates in any trial is not an EIS and the result is noted as "+".

17.5.1.5 *Examples of results*

<b>Substance</b>	<b>Result</b>
HMX/inert binder (86/14), cast	+
HMX/energetic binder (80/20), cast	+
HMX/aluminium/energetic binder (51/19/14), cast	+
RDX/inert binder (85/15), cast	+
RDX/TNT (60/40), cast	+
TATB/Kel-F (95/5), pressed	-
TNT, cast	+



- 
- |                   |                          |
|-------------------|--------------------------|
| (A) Detonator     | (B) Booster charge       |
| (C) PMMA gap      | (D) Substance under test |
| (E) Steel tube    | (F) Air gap              |
| (G) Witness plate |                          |
- 

**Figure 17.5.1.1: EIS GAP TEST**



**17.6 Series 7 type (c) test prescriptions****17.6.1 Test 7 (c) (i): Susan impact test**17.6.1.1 *Introduction*

The Susan Impact test is used to assess the degree of explosive reaction under conditions of high velocity impact. The test is conducted by loading the explosives into standardised projectiles and firing the projectiles against a target at a specified velocity.

17.6.1.2 *Apparatus and materials*

17.6.1.2.1 51 mm diameter, 102 mm long explosives billets, fabricated by normal techniques, are employed.

17.6.1.2.2 The Susan test employs the test vehicle shown in Figure 17.6.1.1. The projectile has an assembled weight of 5.4 kg and contains slightly less than 0.45 kg of explosive. The overall dimensions are 81.3 mm in diameter by 220 mm long.

17.6.1.2.3 The projectiles are fired from a 81.3 mm smooth-bore gun. The gun muzzle is positioned about 4.65 m from the 64 mm thick, smooth-surface, armour steel target plate. Projectile impact velocity is obtained by adjusting the propellant charges in the gun.

17.6.1.2.4 A schematic drawing of the firing range showing the target-gun layout and the relative positions of the diagnostic equipment is shown in Figure 17.6.1.2. The flight path is about 1.2 m above ground level.

17.6.1.2.5 The test site is equipped with calibrated blast gauges and recording equipment. The air blast recording system should have a system frequency response of at least 20 kHz. Measurements are made of impact velocities and air shock blast over-pressure. Air blast is measured at a distance of 3.05 m from the impact point (gauges (C) in Figure 17.6.1.2).

17.6.1.3 *Procedure*

17.6.1.3.1 The propellant charge in the gun should be adjusted to produce a projectile velocity of 333 m/s. The projectile is fired and the impact velocity and air blast, produced as a result of its reaction on impact, are recorded. If a velocity of 333 m/s (+ 10%, - 0%) is not obtained, the amount of propellant is adjusted and the test repeated.

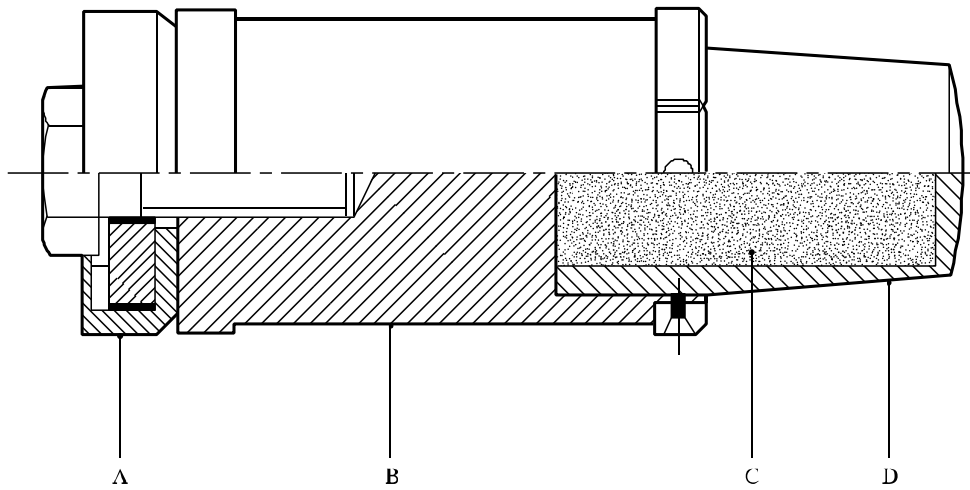
17.6.1.3.2 Once an impact velocity of 333 m/s is obtained, the test is repeated until accurate pressure-time records are obtained from at least five separate shots. On each of these accurate shots, the impact velocity should be 333 m/s (+ 10%, - 0%).

17.6.1.4 *Test criteria and method of assessing results*

The maximum air blast overpressure that is determined from each air blast is recorded. The average of the maximum pressures obtained from the five accurate shots is determined. If the average pressure obtained by such a procedure is greater than or equal to 27 kPa, then the substance is not an EIS explosive and the result is noted as "+".

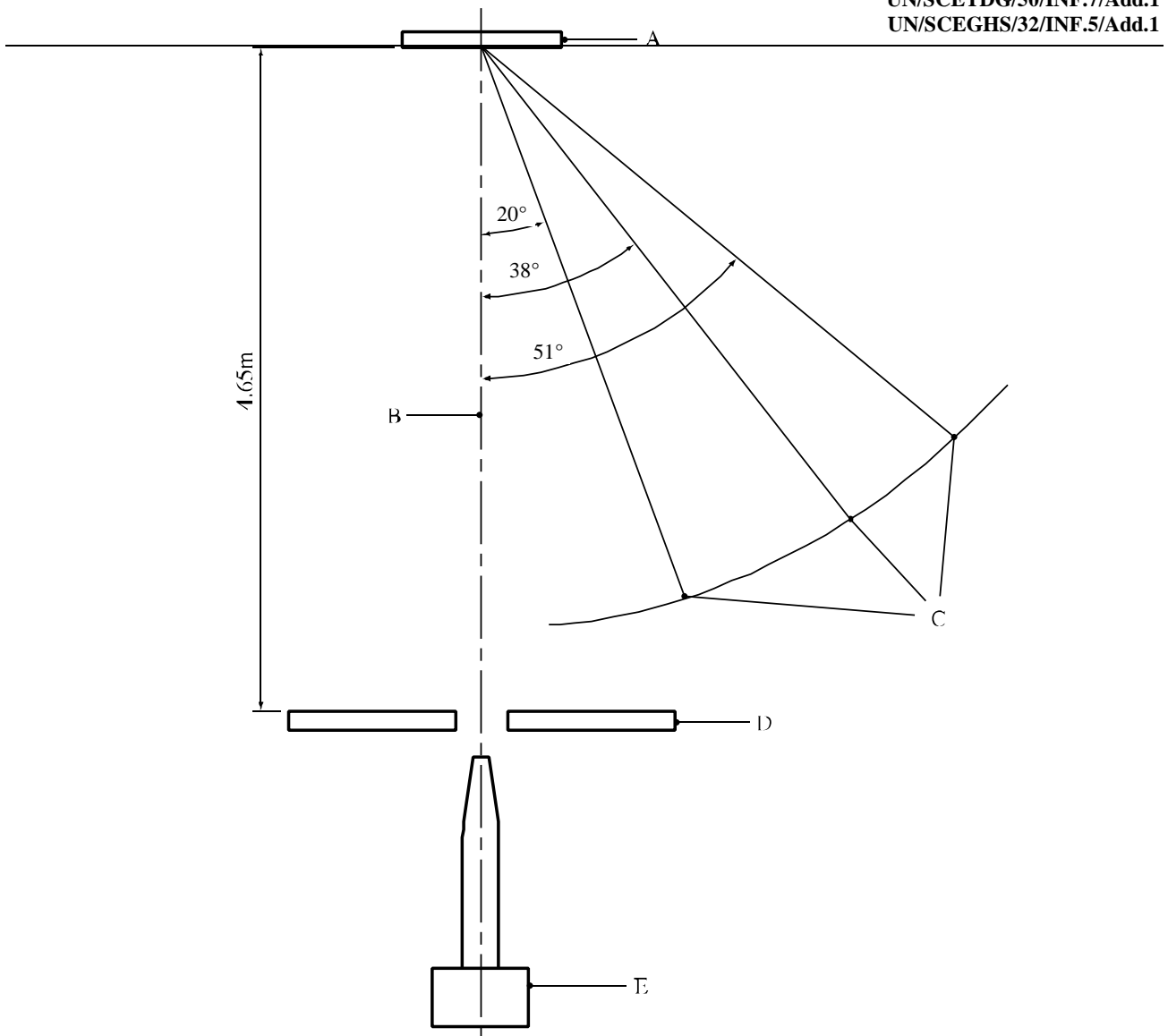
17.6.1.5 *Examples of results*

<b>Substance</b>	<b>Result</b>
HMX/inert binder (86/14), cast	-
HMX/energetic binder (80/20), cast	+
HMX/aluminium/energetic binder (51/19/14), cast	+
RDX/TNT (60/40), cast	+
TATB/Kel-F (95/5), pressed	-



- 
- (A) Leather cup seal
  - (B) Steel body
  - (C) Explosive under test
  - (D) Aluminium cup
- 

**Figure 17.6.1.1: SUSAN PROJECTILE**



- (A) Target plate (6.4 cm thick)
- (B) Flight path
- (C) Air blast transducers (3.05 m from target point)
- (D) Smoke barrier
- (E) 81.3 mm gun

Figure 17.6.1.2: SCHEMATIC LAYOUT OF SUSAN TEST (top view)

---

**17.6.2**            *Test 7 (c) (ii): Friability test*

17.6.2.1           *Introduction*

The friability test is used to establish the tendency of a compact EIS candidate to deteriorate dangerously under the effect of an impact.

17.6.2.2           *Apparatus and materials*

The following apparatus is required:

- (a) A weapon designed to shoot 18 mm diameter cylindrical test pieces at a velocity of 150 m/s;
- (b) A Z30C 13 stainless steel plate, 20 mm thick with a front face roughness of 3.2 microns (AFNOR NF E 05-015 and NF E 05-016 standards);
- (c) A  $108 \pm 0.5 \text{ cm}^3$  manometric bomb at 20 °C;
- (d) A firing capsule containing a heating wire on 0.5 g of black powder with a mean particle size of 0.75 mm. The composition of the black powder is 74% potassium nitrate, 10.5% sulphur and 15.5% carbon. The moisture content should be less than 1%;
- (e) A cylindrical sample of compact substance of diameter  $18 \pm 0.1 \text{ mm}$ . The length is adjusted so as to obtain a mass of  $9.0 \pm 0.1 \text{ g}$ . The sample is brought to and maintained at a temperature of 20 °C;
- (f) A fragment recovery box.

17.6.2.3           *Procedure*

17.6.2.3.1        The sample is projected against the steel plate at an initial velocity sufficient to give an impact velocity as close as possible to 150 m/s. The mass of fragments collected after the impact should be at least 8.8 g. These fragments are fired in a manometric bomb. Three tests are carried out.

17.6.2.3.2        The curve of pressure against time  $p = f(t)$  is recorded; this enables the curve  $(dp/dt) = f'(t)$  to be constructed. From this curve the maximum value  $(dp/dt)_{\text{max}}$  is read off. This enables the value  $(dp/dt)_{\text{max}}$ , corresponding to an impact speed of 150 m/s, to be estimated.

17.6.2.4           *Test criteria and method of assessing results*

If the average maximum  $(dp/dt)_{\text{max}}$  value obtained at a speed of 150 m/s is greater than 15 MPa/ms, the substance tested is not an EIS and the result is noted as "+".

17.6.2.5           *Examples of results*

---

<b>Substance</b>	<b>Result</b>
HMX/inert binder (86/14), cast	-
HMX/energetic binder (80/20), cast	+
HMX/aluminium/energetic binder (51/19/14), cast	-
RDX/TNT (60/40), cast	+
TATB/Kel-F (95/5), pressed	-

---

**17.7 Series 7 type (d) test prescriptions**

**17.7.1 Test 7 (d) (i): EIS bullet impact test**

17.7.1.1 *Introduction*

The bullet impact test is used to evaluate the response of an EIS candidate to the kinetic energy transfer associated with impact and penetration of a given energy source, i.e. a 12.7 mm projectile, travelling at a specified velocity.

17.7.1.2 *Apparatus and materials*

17.7.1.2.1 Explosive test samples fabricated by normal techniques are employed. The samples should have a length of 20 cm and a diameter to allow a close fit into a seamless steel pipe having an inside diameter of 45 mm ( $\pm 10\%$  variation), a wall thickness of 4 mm ( $\pm 10\%$  variation) and a length of 200 mm. The pipes are closed with steel or cast iron end caps, at least as strong as the tube, torqued to 204 Nm.

17.7.1.2.2 The bullet is a standard 12.7 mm armour-piercing bullet with a projectile mass of 0.046 kg, and is fired at the service velocity of about  $840 \pm 40$  m per second from a 12.7 mm gun.

17.7.1.3 *Procedure*

17.7.1.3.1 A minimum of six test articles (explosive substance in a capped steel pipe) should be fabricated for the tests.

17.7.1.3.2 Each test article is positioned on a suitable pedestal at a convenient distance from the muzzle of the gun. Each test article must be secured in a holding device upon its pedestal. This device must be capable of restraining the item against dislodgement by the bullet.

17.7.1.3.3 A test consists of the firing of one projectile into each test item. There should be at least three tests with the test article oriented such that its long axis is perpendicular to the line of flight (i.e. impact through the side of the pipe). There should also be at least three tests with the test article oriented such that its long axis is parallel to the line of flight (i.e. impact through the end cap).

17.7.1.3.4 The remains of the test container are collected. Complete fragmentation of the container is indicative of explosion or detonation.

17.7.1.4 *Test criteria and method of assessing results*

A substance which explodes or detonates in any trial is not an EIS and the result is noted as "+".

17.7.1.5 *Examples of results*

<b>Substance</b>	<b>Result</b>
HMX/inert binder (86/14), cast	-
HMX/energetic binder (80/20), cast	+
HMX/aluminium/energetic binder (51/19/14), cast	-
RDX/TNT (60/40), cast	+
TATB/Kel-F (95/5), pressed	-

---

**17.7.2**            *Test 7 (d) (ii): Friability test*

17.7.2.1           *Introduction*

The friability test is used to evaluate the response of an EIS candidate to the kinetic energy transfer associated with impact and penetration of a given energy source travelling at a specified velocity.

17.7.2.2           *Apparatus and materials*

The following apparatus is required:

- (a) A weapon designed to shoot 18 mm diameter cylindrical test pieces at a velocity of 150 m/s;
- (b) A Z30C 13 stainless steel plate, 20 mm thick with a front face roughness of 3.2 microns (AFNOR NF E 05-015 and NF E 05-016 standards);
- (c) A  $108 \pm 0.5 \text{ cm}^3$  manometric bomb at 20 °C;
- (d) A firing capsule containing a heating wire on 0.5 g of black powder with a mean particle size of 0.75 mm. The composition of the black powder is 74% potassium nitrate, 10.5% sulphur and 15.5% carbon. The moisture content should be less than 1%;
- (e) A cylindrical sample of compact substance of diameter  $18 \pm 0.1 \text{ mm}$ . The length is adjusted so as to obtain a mass of  $9.0 \pm 0.1 \text{ g}$ . The sample is brought to and maintained at a temperature of 20 °C;
- (f) A fragment recovery box.

17.7.2.3           *Procedure*

17.7.2.3.1        The sample is projected against the steel plate at an initial velocity sufficient to give an impact velocity as close as possible to 150 m/s. The mass of fragments collected after the impact should be at least 8.8 g. These fragments are fired in a manometric bomb. Three tests are carried out.

17.7.2.3.2        The curve of pressure against time  $p = f(t)$  is recorded; this enables the curve  $(dp/dt) = f'(t)$  to be constructed. From this curve the maximum value  $(dp/dt)_{\text{max}}$  is read off. This enables the value  $(dp/dt)_{\text{max}}$ , corresponding to an impact speed of 150 m/s, to be estimated.

17.7.2.4           *Test criteria and method of assessing results*

If the average maximum  $(dp/dt)_{\text{max}}$  value obtained at a speed of 150 m/s is greater than 15 MPa/ms, the substance tested is not an EIS and the result is noted as "+".

17.7.2.5           *Examples of results*

---

<b>Substance</b>	<b>Result</b>
HMX/inert binder (86/14), cast	-
HMX/energetic binder (80/20), cast	+
HMX/aluminium/energetic binder (51/19/14), cast	-
RDX/TNT (60/40), cast	+
TATB/Kel-F (95/5), pressed	-

---

**17.8 Series 7 type (e) test prescription**

**17.8.1 Test 7 (e): EIS external fire test**

17.8.1.1 *Introduction*

The external fire test is used to determine the reaction of an EIS candidate to external fire when it is confined.

17.8.1.2 *Apparatus and materials*

Explosive test samples fabricated by normal techniques are employed. The samples should have a length of 20 cm and a diameter to allow a close fit into a seamless steel pipe having an inside diameter of 45 mm ( $\pm 10\%$  variation), a wall thickness of 4 mm ( $\pm 10\%$  variation) and a length of 200 mm. The pipes are closed with steel or cast iron end caps, at least as strong as the tube, torqued to 204 Nm.

17.8.1.3 *Procedure*

17.8.1.3.1 The experimental procedure is the same as for test 6 (c) (see 16.6.1.3) except as noted in paragraph 17.8.1.3.2 below.

17.8.1.3.2 The test is conducted as:

- (a) One fire engulfing fifteen confined samples, stacked in three adjacent piles of two samples banded on top of three samples; or
- (b) Three fires in which five samples are laid out horizontally and banded together.

Colour photographs are taken to document the condition of the samples after each test. Cratering and the size and location of confining pipe fragments are documented as an indication of the degree of reaction.

17.8.1.4 *Test criteria and method of assessing results*

An explosive substance which detonates or reacts violently with fragments thrown more than 15 m is not an EIS and the result is noted as "+".

17.8.1.5 *Examples of results*

Substance	Result
HMX/inert binder (86/14), cast	-
HMX/inert binder (85/15), cast	-
HMX/energetic binder (80/20), cast	+
HMX/aluminium/energetic binder (51/19/14), cast	-
RDX/inert binder (85/15), cast	+
RDX/TNT (60/40), cast	+
TATB/Kel-F (95/5), pressed	-

---

**17.9 Series 7 type (f) test prescription**

**17.9.1 Test 7 (f): EIS slow cook-off test**

17.9.1.1 *Introduction*

This test is used to determine the reaction of an EIS candidate to a gradually increasing thermal environment and to find the temperature at which reaction occurs.

17.9.1.2 *Apparatus and materials*

17.9.1.2.1 Explosive test samples fabricated by normal techniques are employed. The samples should have a length of 200 mm and a diameter to allow a close fit into a seamless steel pipe having an inside diameter of 45 mm ( $\pm$  10% variation), a wall thickness of 4 mm ( $\pm$  10% variation) and a length of 200 mm. The pipes are closed with steel or cast iron end caps, at least as strong as the tube, torqued to 204 Nm.

17.9.1.2.2 The sample assembly is placed in an oven which provides a controlled thermal environment over a 40 °C to 365 °C temperature range and can increase the temperature of the surrounding oven atmosphere at the rate of 3.3 °C per hour throughout the temperature operating range and ensure, by circulation or other means, a uniform thermal environment to the item under test.

17.9.1.2.3 Temperature recording devices are used to monitor temperature at 10 minute or less intervals; continuous monitoring is preferred. Instrumentation with an accuracy of  $\pm$  2 per cent over the test temperature range is used to measure the temperature of:

- (a) The air within the oven; and
- (b) The exterior surface of the steel pipe.

17.9.1.3 *Procedure*

17.9.1.3.1 The test item is subjected to a gradually increasing air temperature at a rate of 3.3 °C per hour until reaction occurs. The test may begin with the test item pre-conditioned to 55 °C below the anticipated reaction temperature. The onset temperature at which the sample temperature exceeds the oven temperature should be recorded.

17.9.1.3.2 After the completion of each test, the pipe or any fragments of pipe are recovered in the test area and examined for evidence of violent explosive reaction. Colour photographs may be taken to document the condition of the unit and the test equipment before and after the test. Cratering, and the size and location of any fragments, may also be documented as indications of the degree of reaction.

17.9.1.3.3 Three tests are conducted for each candidate substance unless a positive result is observed earlier.

17.9.1.4 *Test criteria and method of assessing results*

A substance which detonates or reacts violently (fragmentation of one or two end caps and fragmentation of the tube into more than three pieces) is not considered an EIS and the result is noted as "+".

17.9.1.5 *Examples of results*

---

<b>Substance</b>	<b>Result</b>
HMX/inert binder (86/14), cast	-
HMX/energetic binder (80/20), cast	+
RDX/TNT (60/40), cast	+
TATB/Kel-F (95/5), pressed	-

---



---

**17.10**            **Series 7 type (g) test prescription**

**17.10.1**            ***Test 7 (g): 1.6 article (or component level) external fire test***

17.10.1.1            *Introduction*

The external fire test is used to determine the reaction of a possible Division 1.6 article to external fire as presented for [transport classification](#).

17.10.1.2            *Apparatus and materials*

The experimental set-up for this test is the same as for test 6 (c) (see 16.6.1.2).

17.10.1.3            *Procedure*

17.10.1.3.1        The experimental procedure for this test is the same as for test 6 (c) (see 16.6.1.3), except that, if the volume of single item exceeds 0.15 m<sup>3</sup>, only one item is required.

17.10.1.3.2        Colour still photographs are taken to document the condition of the test item and the test equipment before and after the test. Explosive substance remains, fragmentation, blast, projections, cratering, witness screen damage, and thrust are documented as an indication of the article's response level.

17.10.1.3.3        Colour video for the duration of each trial can be vital to assessment of response. In sitting the camera(s), it is important to ensure that the field of view will not be obstructed by any of the test facilities or instrumentation and that the field of view will include all necessary information.

17.10.1.3.4        To classify complex articles containing multiple EIS main explosive loads, external fire testing at the individual main load component level should be conducted to fully characterise the article's response level.

17.10.1.4            *Test criteria and method of assessing results*

If there is a response level more severe than burning as outlined in Appendix 8, the result is noted as "+" and the items are not classified as Division 1.6 articles.

**17.11**            **Series 7 type (h) test prescription**

**17.11.1**            ***Test 7 (h): 1.6 article or component level slow cook-off test***

17.11.1.1            *Introduction*

This test is used to determine the reaction of a candidate Division 1.6 article to a gradually increasing thermal environment and to find the temperature at which reaction occurs.

17.11.1.2            *Apparatus and materials*

17.11.1.2.1        The test equipment consists of an oven which provides a controlled thermal environment over a 40 °C to 365 °C temperature range and can increase the temperature of the surrounding oven atmosphere at the rate of 3.3 °C per hour throughout the temperature operating range, minimize hot spots, and ensure (by circulation or other means) a uniform thermal environment to the item under test. Secondary reactions (such as those caused by exudate and explosive gases contacting the heating devices) invalidate the test, but these can be avoided by providing a sealed inner container to surround [bare](#) articles ~~transported bare~~. A means of relief should be provided for the increased air pressure generated during the test due to heating.

17.11.1.2.2        Temperature recording devices (permanent record types) are used to monitor temperature continuously or, at least, every 10 minutes. Instrumentation with an accuracy of  $\pm 2\%$  over the test temperature range is used to measure the temperature at:

- (a)    The atmosphere air gap adjacent to the unit under test; and
- (b)    The exterior surface of the unit.

17.11.1.3            *Procedure*

17.11.1.3.1        The test item is subjected to a gradually increasing, at a rate of 3.3 °C per hour, air temperature until unit reaction occurs. The test may begin with the test item pre-conditioned to 55 °C below the predicted reaction temperature. Temperatures and elapsed test time are measured and recorded.

17.11.1.3.2        Colour still photographs are taken to document the condition of the test item and the test equipment before and after the test. Explosive substance remains, fragmentation, blast, projections, cratering, witness plate damage, and thrust are documented as an indication of the article's response level. Colour video for the duration of each trial can be vital to assessment of response. In sitting the camera(s), it is important to ensure that the field of view will not be obstructed by any of the test facilities or instrumentation and that the field of view will include all necessary information.

17.11.1.3.3        The test is conducted twice unless a positive result is obtained earlier. To classify complex articles containing multiple EIS main explosive loads, slow cook-off testing at the individual main load component level should be conducted to fully characterise the article's response level.

17.11.1.4            *Test criteria and method of assessing results*

If there is a response level more severe than burning as outlined in Appendix 8, the result is noted as "+" and the items are not classified as Division 1.6 articles.

---

**17.12 Series 7 type (j) test prescription**

**17.12.1 Test 7 (j): 1.6 article or component bullet impact test**

17.12.1.1 *Introduction*

The bullet impact test is used to evaluate the response of a candidate Division 1.6 article to the kinetic energy transfer associated with the impact and penetration by a given energy source.

17.12.1.2 *Apparatus and materials*

Three 12.7 mm gun are used to fire service 12.7 mm armour-piercing ammunition with a projectile mass of 0.046 kg. Standard propellant loads may require adjustment to achieve projectile velocities within tolerance. The guns are fired by remote control and protected from fragment damage by firing through a hole in a heavy steel plate. The firing gun muzzle should be at a maximum range of at least 10 m from the test item to assure stabilization prior to impact, and at a maximum range of 30 m from the test item depending upon the explosive weight of the test item. The test item should be secured in a holding device capable of restraining the item against dislodgement by the projectiles.

17.12.1.3 *Procedure*

17.12.1.3.1 The candidate Division 1.6 article is subjected to a three-round burst fired at  $840 \pm 40$  m/s velocity and 600 rounds/minute rate of fire. The test is repeated in three different orientations striking the test item in the most vulnerable areas as assessed by the competent authority. These are areas for which an assessment of the explosive sensitivity (explosiveness and sensitiveness) combined with knowledge of the article design indicate the potential producing the most violent response level.

17.12.1.3.2 Colour still photographs are taken to document the condition of the test item and the test equipment before and after the test. Explosive substance remains, fragmentation, blast, projections, cratering, witness plate damage, and thrust are documented as an indication of the article's response level.

17.12.1.3.3 Colour video for the duration of each trial can be vital to assessment of response. In sitting the camera(s), it is important to ensure that the field of view will not be obstructed by any of the test facilities or instrumentation and that the field of view will include all necessary information.

17.12.1.3.4 To classify complex articles containing multiple EIS main explosive loads, bullet impact testing at the individual main load component level should be conducted to fully characterise the article's response level.

17.12.1.4 *Test criteria and method of assessing results*

If there is a response level more severe than burning as outlined in Appendix 8, the result is noted as "+" and the items are not classified as Division 1.6 articles.

**17.13 Series 7 type (k) test prescription**

**17.13.1 Test 7 (k): 1.6 article stack test**

17.13.1.1 *Introduction*

This test is used to determine whether a detonation of a candidate Division 1.6 article, as offered for [transport classification](#), will initiate a detonation in an adjacent, like article.

17.13.1.2 *Apparatus and materials*

The experimental set-up is the same as for test 6 (b) (see 16.5.1.2), with one trial conducted confined, and another unconfined. The test should only be conducted on detonable candidate Division 1.6 articles; the test 7 (k) article stack test is waived for non-detonable candidates for Division 1.6 (evidence is available to demonstrate that the article cannot support a detonation). Where the article is designed to provide a detonation output, the article's own means of initiation or a stimulus of similar power shall be used to initiate the donor. If the article is not designed to detonate but is capable of supporting a detonation, the donor shall be detonated using an initiation system selected to minimise the influence of its explosive effects on the acceptor article(s).

17.13.1.3 *Procedure*

The experimental set-up is the same as for test 6 (b) (see 16.5.1.3). [The test is performed twice unless detonation of an acceptor is observed earlier.](#) Colour still photographs are taken to document the condition of the test item and the test equipment before and after the test. Explosive substance remains, fragmentation, blast, projections, cratering, witness plate damage, and thrust are documented and used to assess whether or not any acceptor has detonated (including partially). Blast data may be used to supplement this decision. Colour video for the duration of each trial can be vital to assessment of response. In sitting the camera(s), it is important to ensure that the field of view will not be obstructed by any of the test facilities or instrumentation and that the field of view will include all necessary information. Comparing data from the two stack test trials to data from a single donor calibration shot, or to a calculated donor detonation pressure, can be useful in assessing the response level of acceptors.

[\(Note by the secretariat: Correction to the 6th revised edition. Refer to ST/SG/AC.10/11/Rev.6/Corr.1\)](#)

17.13.1.4 *Test criteria and method of assessing results*

If detonation in the stack is propagated from the donor to an acceptor, the test result is noted as "+" and the article cannot be assigned to Division 1.6. Acceptor article response levels assessed as no reaction, burning, deflagration or explosion as outlined in Appendix 8 are considered as negative results and noted as "-".

---

**17.14 Series 7 type (I) test prescription**

**17.14.1 Test 7 (I): 1.6 article (or component level) fragment impact test**

17.14.1.1 *Introduction*

This test is used to determine the response of an article in its ~~transport-normal~~ configuration to a localised shock input representative of a fragment strike typical of that produced from a nearby detonating article.

17.14.1.2 *Apparatus and materials*

To reduce variability due to yaw, a gun system is recommended for firing a standard 18.6 g steel fragment in the shape of a right-circular cylinder with a conical nose, as detailed in Figure 17.14.1, at a candidate Division 1.6 article. The distance between the firing device and the test item should ensure that the fragment is ballistically stable at impact. Barricades should protect the remote control gun system from the potential damaging effects of the test item's reaction.

17.14.1.3 *Procedure*

17.14.1.3.1 The test is repeated in two different orientations, striking the test item in the most vulnerable areas as assessed by the competent authority. These are areas for which an assessment of the explosive sensitivity (explosiveness and sensitiveness) combined with knowledge of the article design indicate the potential for producing the most violent response level. Typically, one test would be conducted targeting a non-EIS boosting component and the second test would target the centre of the main explosive load. The orientation of impact should generally be normal to the outer surface of the article. The fragment impact velocity should be  $2530 \pm 90$  m/s.

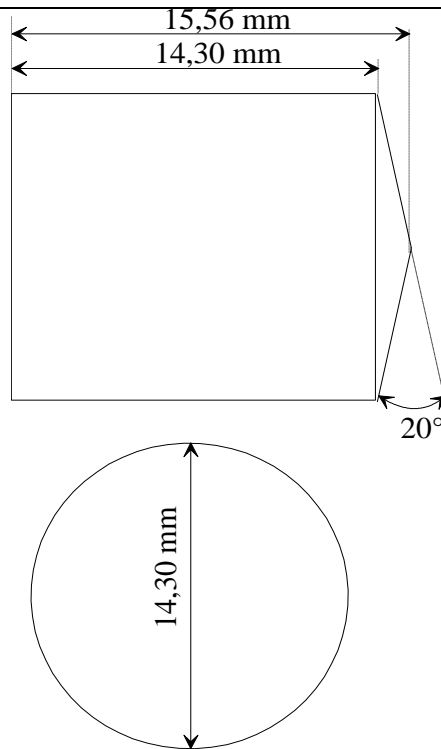
17.14.1.3.2 Colour still photographs are taken to document the condition of the test item and the test equipment before and after the test. Explosive substance remains, fragmentation, blast, projections, cratering, witness plate damage, and thrust are documented as an indication of the article's response level.

17.14.1.3.3 Colour video for the duration of each trial can be vital to assessment of response. In sitting the camera(s), it is important to ensure that the field of view will not be obstructed by any of the test facilities or instrumentation and that the field of view will include all necessary information.

17.14.1.3.4 To classify complex articles containing multiple EIS main explosive loads, fragment impact testing at the individual main load component level should be conducted to fully characterise the article's response level.

17.14.1.4 *Test criteria and method of assessing results*

If there is a response level more severe than burning as outlined in Appendix 8, the result is noted as "+" and the items are not classified as Division 1.6 articles.



**Notes:**

*Shape:* a conical ended cylinder with the ratio

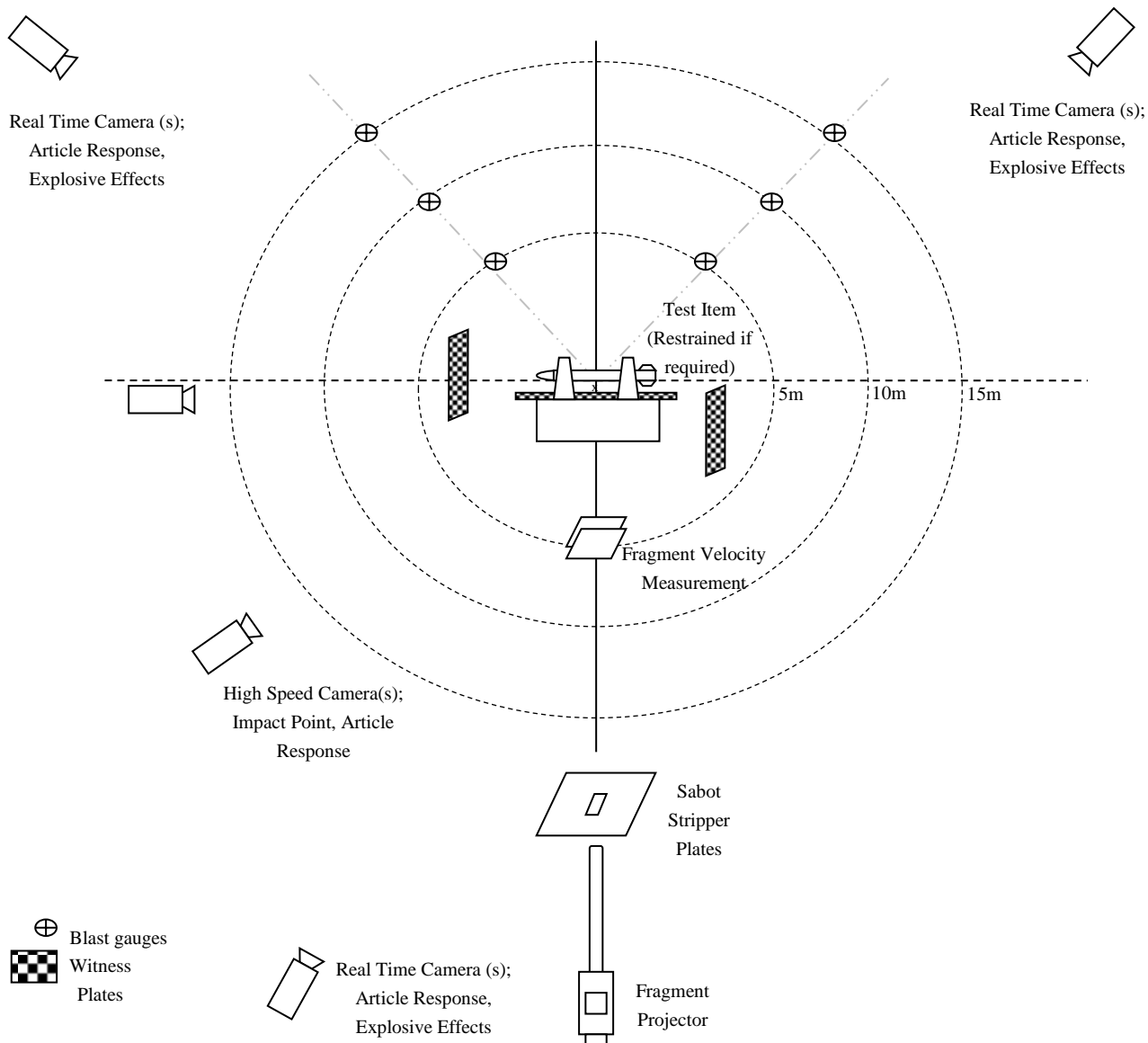
$$\frac{L \text{ (length)}}{D \text{ (diameter)}} > 1 \quad \text{for stability;}$$

*Tolerances:*  $\pm 0.05 \text{ mm}$  and  $\pm 0^\circ 30'$ ;

*Fragment mass:* 18.6 g;

*Fragment material:* a mild carbon steel with a Brinell Hardness (HB) less than 270.

**Figure 17.14.1: STANDARD FRAGMENT FOR 1.6 ARTICLE FRAGMENT IMPACT TEST**



**Figure 17.14.2: TYPICAL SETUP FOR 1.6 ARTICLE FRAGMENT IMPACT TEST**