



# Membrane tanks on inland gas tankers

## Inland Transport Committee



© GTT - Roland Mouron

August 2018

Safety

Excellence

Innovation

Teamwork

Transparency

*This document contains information resulting from testing, experience and know-how of GTT, which are protected under the legal regime of undisclosed information and trade secret (notably TRIPS Art. 39) and under Copyright law. This document is strictly confidential and the exclusive property of GTT. It cannot be copied, used, modified, adapted, disseminated, published or communicated, in whole or in part, by any means, for any purpose, without express prior written authorization of GTT. Any violation of this clause may give rise to civil or criminal liability - © GTT 2010 - 2018*

1

---

ADN supports innovation

# Directive 2014/94/EU ... on the deployment of alternative fuels infrastructure

Whereas No. (20) of the Directive

Trans-European Network for Transport (TEN-T) guidelines

...

- Enhance the environmental performance of the transport sector
- The TEN-T guidelines also require that inland and sea ports, ... provide for the availability of alternative fuels



MINISTÈRE  
DE LA TRANSITION  
ÉCOLOGIQUE  
ET SOLIDAIRE  
4

# Regulation (EU) 2016/1628 ... on requirements relating to gaseous and particulate pollutant emission limits ... (“NRMM” Regulation)

## Dealing with gaseous and particulate pollutant emission limits

- Whereas Nos (3), (5), (24) ...
- Article 1 / Article 5 of the Regulation
- Gaseous pollutants defined (in article 3) as carbon monoxide (CO), total hydrocarbons (HC) and oxides of nitrogen (NOx)



MINISTÈRE  
DE LA TRANSITION  
ÉCOLOGIQUE  
ET SOLIDAIRE  
5

# Whereas No. (42) of the Directive 2014/94/EU

LNG is an attractive fuel alternative for vessels to meet the requirements for decreasing the sulphur content in marine fuels in the SOx Emission Control Areas

- Directive (EU) 2016/802 ... relating to a reduction in the sulphur content of certain liquid fuels (→ codifies and repeals Directive 1999/32/EC and its successive amendments); and
- MARPOL Annex VI (IMO - International Maritime Organization)

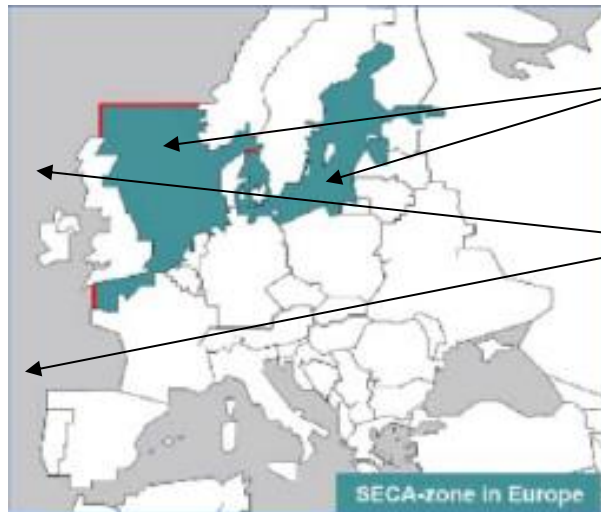

Sulphur content of fuel permitted inside Control Areas  
→ 0,1 % (by mass) as from 01/01/2015

Sulphur content of fuel permitted outside Control Areas  
→ 3,5 % (by mass) currently  
→ 0,5 % (by mass) as from 01/01/2020

**SOx Emission Control Areas in Europe (SECA's)**

# Whereas No. (34) of the Directive 2014/94/EU

Shore-side electricity facilities can serve maritime and inland waterway transport as clean power supply, in particular in maritime and inland navigation ports where air quality or noise levels are poor. Shore-side electricity can contribute to reducing the environmental impact of sea-going ships and inland waterway vessels.

## Article 7 of the Directive (EU) 2016/802

“Maximum sulphur content of marine fuels used by ships at berth in Union ports”

Member States shall take all necessary measures to ensure that ships at berth in Union ports (except ships are due to be at berth for less than two hours) do not use marine fuels with a sulphur content exceeding 0,10 % by mass, ...



MINISTÈRE  
DE LA TRANSITION  
ÉCOLOGIQUE  
ET SOLIDAIRE

7

# LNG is the cleanest of all existing marine and inland waterways fuels

It is generally admitted(\*) that, compared with the “classical” fossil fuels the use of LNG as fuel:

- Eliminates nearly all emissions of SOx and fine particles; and
- Reduces NOx emissions by 85-90%; and
- Reduces CO2 emissions by up to 25%

(\*) Source:

“Contribution of AFG (French Gas Association) to the national policy framework for the deployment of alternative fuel infrastructures (AFNPF)”



MINISTÈRE  
DE LA TRANSITION  
ÉCOLOGIQUE  
ET SOLIDAIRE  
8



# Whereas No. (43) of the Directive 2014/94/EU

The Commission and the Member States should endeavour to modify the European Agreement concerning the International Carriage of Dangerous Goods by Inland Waterways, concluded at Geneva on 26 May 2000, as amended (ADN), to allow large-scale carriage of LNG on inland waterways.

A first stage to reach this objective has been the entry in force of the amendments 2015 to the Annexed regulations to ADN, allowing the carriage in LNG in bulk onboard Inland Waterways tank vessels in tanks G (Type of tank vessel), 1 (Cargo tank design), 1 (Cargo tank type)



MINISTÈRE  
DE LA TRANSITION  
ÉCOLOGIQUE  
ET SOLIDAIRE<sup>9</sup>

# Whereas No. (43) of the Directive 2014/94/EU (continued)

Directive 2006/87/EC ... should be amended, where necessary, to allow the efficient and safe use of LNG for propulsion of vessels on inland waterways.

This objective is or will be reached with the Directive (EU) 2016/1629 and the amendments 2019 to the Annexed regulations to ADN, which refer to in Chapter 30 and Annex 8, Section 1 of the ES-TRIN

## LNG as fuel for propulsion of seagoing vessels

The use of LNG as fuel for propulsion is allowed by:

- SOLAS Convention, Chapter II-1, Part G, Regulations 56 and 57;
- Using as technical standard Parts A and A-1 of the International code of safety for ships using gases or other low-flashpoint fuels (IGF Code) (IMO Resolution MSC.391(95))



MINISTÈRE  
DE LA TRANSITION  
ÉCOLOGIQUE  
ET SOLIDAIRE

# The demand for LNG might significantly increase in the upcoming years

- The relevant instruments and standards (ES-TRIN, IGF Code) are existing → safe design and safe operation for vessels and ships using LNG as fuel for propulsion
- Necessity to carry out these transports safely and in greater quantities and tonnages than the current ones.

The membrane tank technology is the most relevant solution to perform these transports in larger quantities (see illustration here under)

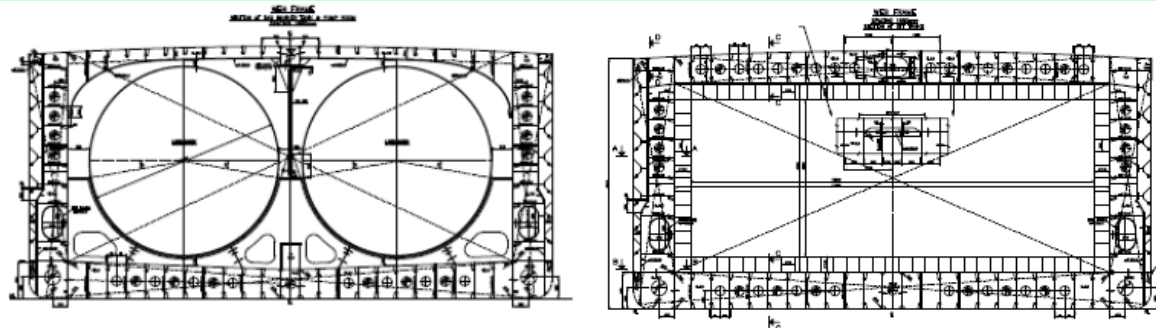

Extract from WP.15/AC.2/27/INF.06 (ARGOS Project)  
4 x 300 m<sup>3</sup>                      2 x 935 m<sup>3</sup>

# The demand for LNG might significantly increase in the upcoming years (continued)

- The transport of LNG by inland waterways is one of the most flexible and efficient means to meet the growing demand.
- In order to fulfill the objectives of whereas No. 20 of the Directive 2014/94/EU, the transport by inland waterways is fully relevant to supply with LNG the places which cannot be supplied with (maritime) Gas Carriers or pipelines:
  - (Small) maritime ports;
  - Inland waterways ports

# The demand for LNG might significantly increase in the upcoming years (continued)

Existing demand emanating from vessels owners and operators

EBU communiqué (20/06/2017)

## “EBU engaged for the greening of the European fleet”

- “Finally, EBU stresses the importance that the inland waterway industry attaches to ... the introduction of the all existing LNG packaging processes and techniques recognized and accepted by maritime regulations.”
- “... EBU regrets that, due to the current provisions of ADN, the river industry cannot yet resort to all existing LNG conditioning technologies used in maritime transport.”
- “EBU therefore calls for ADN to adopt membrane tank process for transport of LNG as soon as possible.”



MINISTÈRE  
DE LA TRANSITION  
ÉCOLOGIQUE  
ET SOLIDAIRE

13

# The membrane tank technology used on inland waterways vessels is fully relevant

This technology is used, and recognized as fully safe, in maritime transport of LNG for more than 50 years.

More recently, this technology has been allowed for the LNG fuel tanks, in the frame of the (maritime) IGF Code.

The accumulated knowledge and experience are very significant:

- For the seagoing vessels owners and operators involved in the carriage in bulk of LNG in membrane tanks by seaway; and
- For the maritime competent authorities; and
- For the main (maritime) Classification Societies



MINISTÈRE  
DE LA TRANSITION  
ÉCOLOGIQUE  
ET SOLIDAIRE

14

# 2

---

## Membrane tanks on inland vessels

# Membrane tanks on inland vessels (animation)

Animation movie is summarized below:

- Context :
  - Global sulphur cap 2020, ECA.
  - LNG is the right solution for shipping fuel, but also for inland power plants, industry and trucks
- Membrane System :
  - LNG transportation in bulk thanks to membrane system.
  - Safety by design: 4 barriers = complete double hull + secondary and primary membranes.
- Membrane advantages
  - Resist to large deformation
  - Additional safety systems : temperatures, pressure, gas analyser
  - Compactness
  - Flexibility for various liquefied gases



# 3

---

Focus on Membrane Tanks Safety

# Membrane concept

- The containment system transfer the loads to the hulls, which carry the loads
- Insulation function and LNG tightness are done by separate components

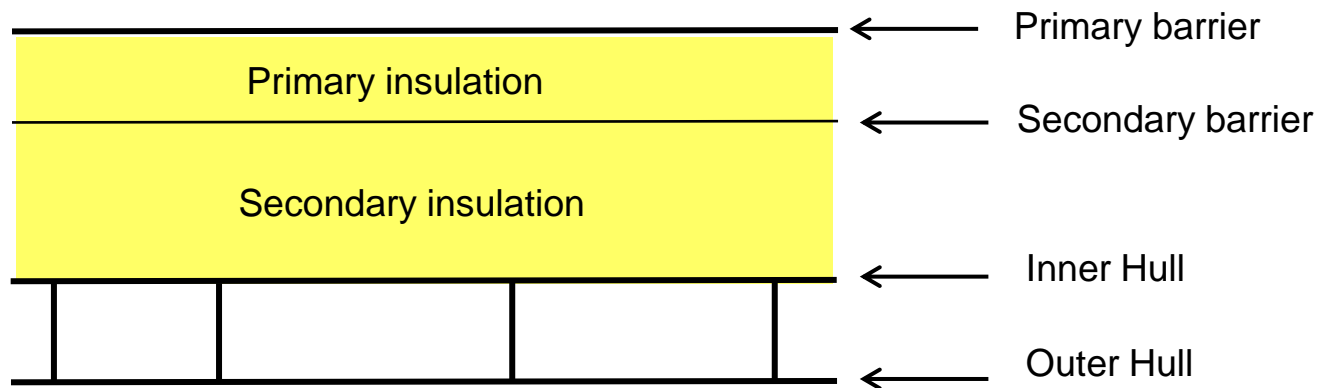

- Full redundancy ensured by a complete secondary barrier

# Insulation Spaces Monitoring

- Inerting of each insulation space with nitrogen
- Automatic Pressure control
- Gas detection
- Temperature sensors network

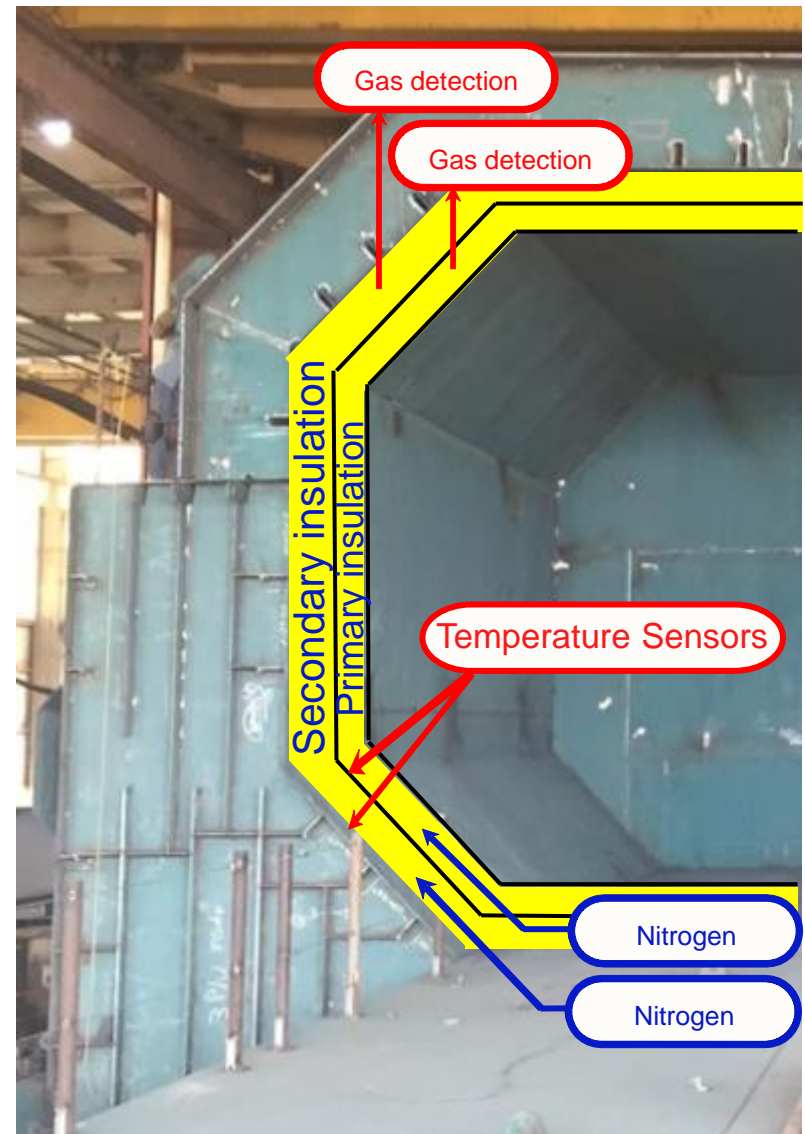

# Mark III Technology safety statistics

- Sea-proven technology

- Present range of tank capacities in operation from **315** to **58,600 m<sup>3</sup>**.
- More than **50 years** of experience, around 200 ships in service representing around **800 tanks** equipped with Mark III containment system currently at sea.
- Mark III containment system has **never** faced a **loss of integrity**.

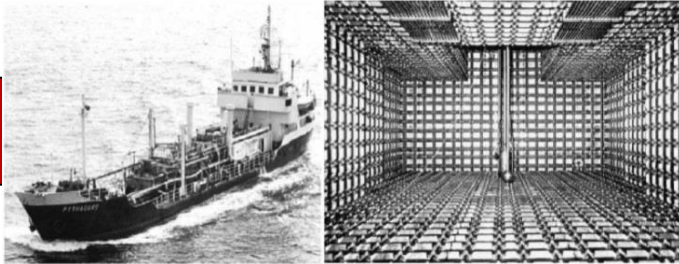

1964 : Pythagore LNG carrier - 630 m<sup>3</sup> (2 tanks)



2017 : Shell Prelude FLNG – 326 000 m<sup>3</sup> (10 tanks)

# COLLISION RESISTANCE: REX from the field

In September 2003, Korean shipyards were hit by “Maemi” **typhoon**, resulting in **severe damages** on numerous LNG vessels under construction.

Some vessels ran aground, and many **outer hull deformations** were observed including holes.

**Membrane systems** were **not affected** by those outer hull deformations.



# COLLISION RESISTANCE : model tests

- Tests in laboratory recognized by Administration demonstrates that with **100 mm vertical displacement** of the membrane, **no loss of tightness** has been observed

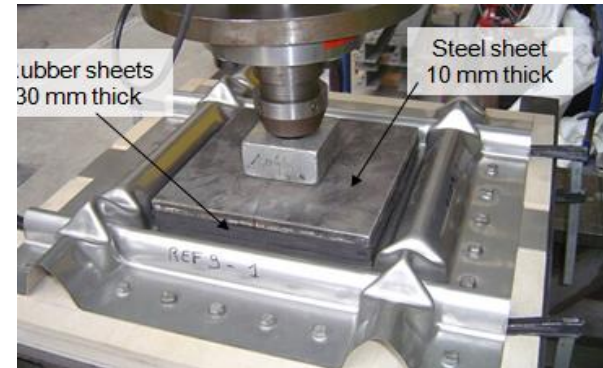

- Full **unfolding tests** of both small and large corrugation, **no crack observed**

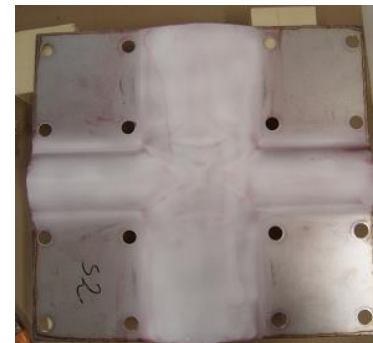

Sample 1-Face 1



Sample 1-Face 2



# COLLISION RESISTANCE: Hamburg University - DNV GL - GTT cooperation program

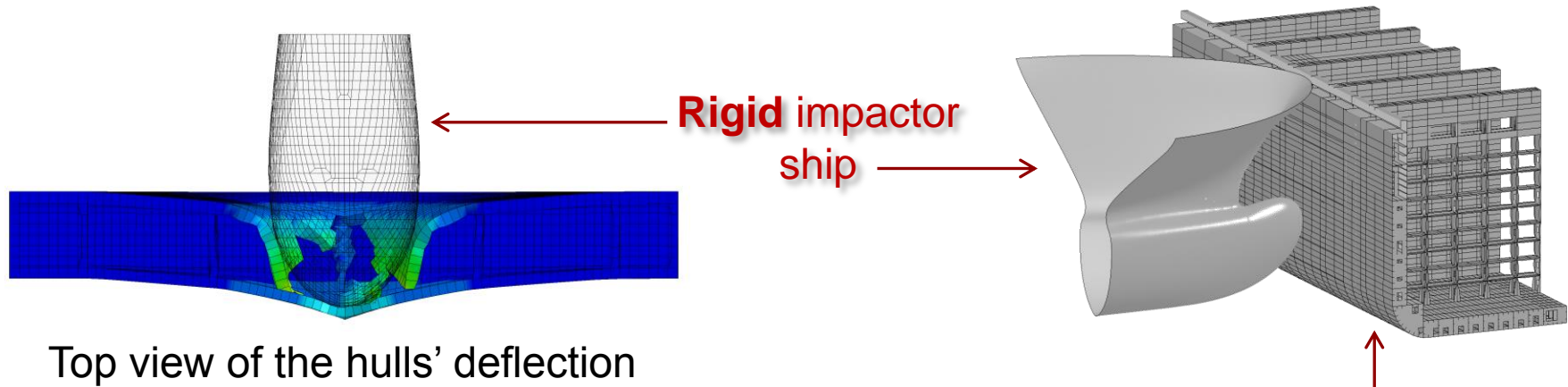

TUHH LAB TEST

# COLLISION RESISTANCE: Hamburg University - DNV GL - GTT cooperation program

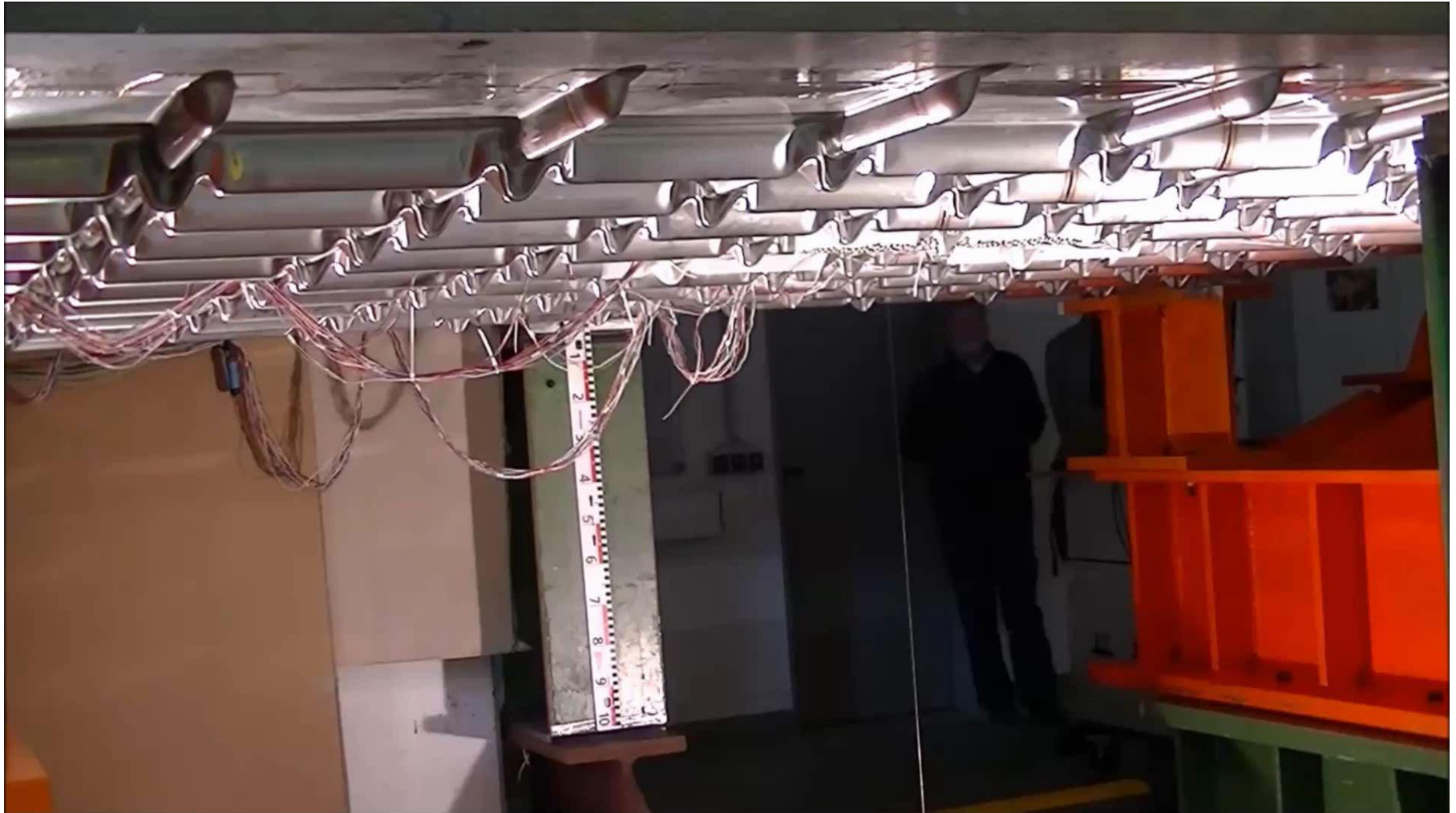



# COLLISION RESISTANCE: Hamburg University - DNV GL - GTT cooperation program

Summary of test results:

- Small corrugations completely unfolded
- Bulb displacement of **1m on 3m** of Mark III membrane
- No **loss of tightness**

# COLLISION RESISTANCE: Hamburg University - DNV GL - GTT cooperation program

- Extrapolation of test results
  - With **24 m span**, this would be equivalent to a **8 m penetration** of the inner hull, with **no loss of containment**
  - In term of collision energy: **~ 1250 MJ**
  - Equivalent to a vessel of **100,000T at 9.8 knots**
- Membrane can adapt to **very large deformations** which could occur during a collision case **without loss of tightness.**



TUHH LAB TEST



# Membrane Compactness

- Membrane, as a fully integrated containment system, allows more compact designs. It is possible to carry up to **55% more cargo** compared to other technologies in the same vessel dimensions.

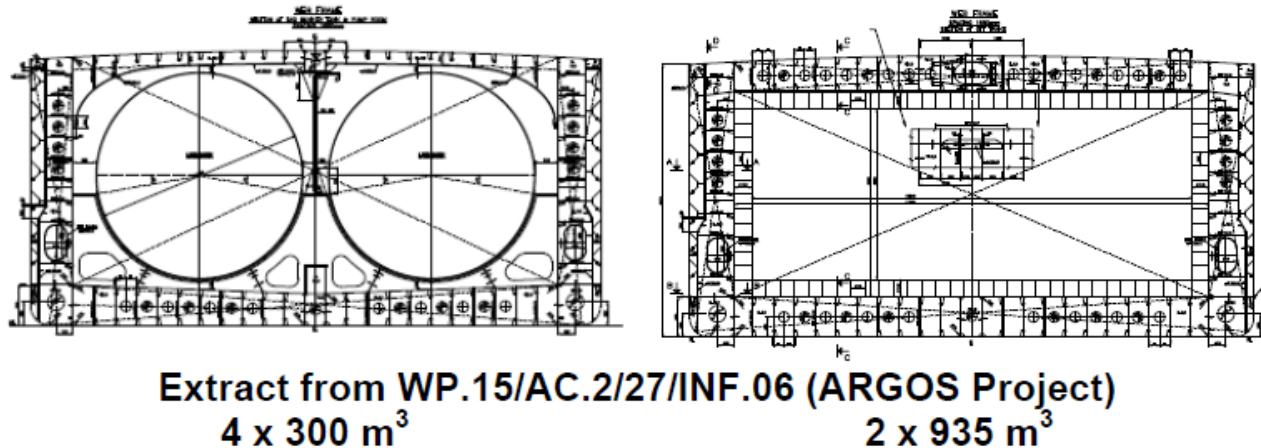

- Less vessels means
  - lower collision probability
  - less transfer operations, lower risk of leakage

# Recently delivered in USA: 2,200cbm LNG barge

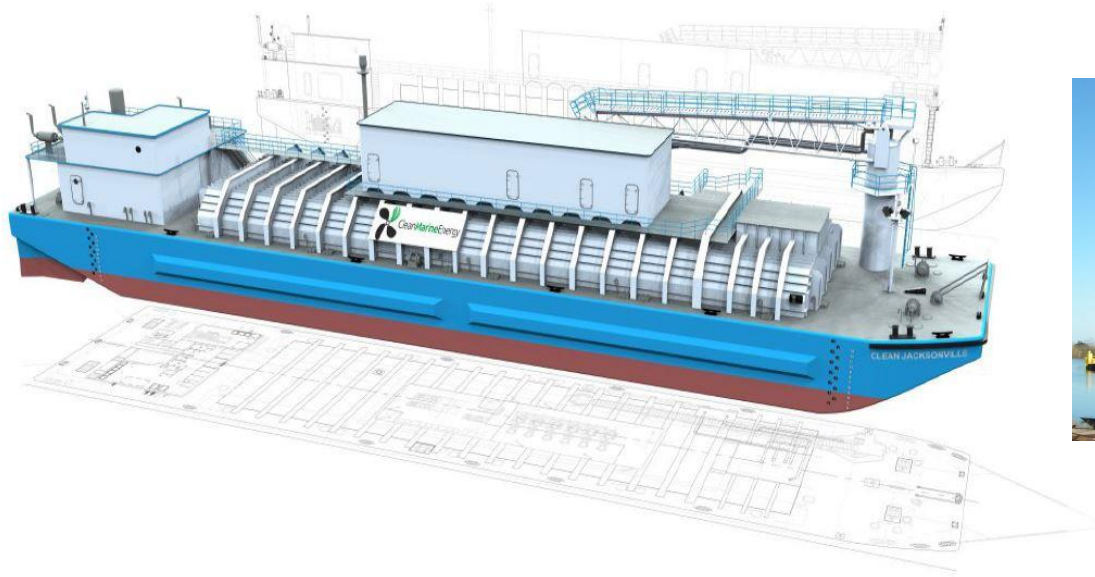

# 4

---

Next steps proposal

# Transport of LNG in bulk by Inland Waterways in membrane tanks - Conclusions and future steps

## First issue

Does the Safety Committee desire or not the Informal Working Group pursuing its work?

## Second issue

Subject to the agreement for continuing its work, the IWG wishes to know whether the Safety Committee can accept or not the principle of a suitable procedure for assessment of membrane tanks outside the framework of a derogation under ADN 1.5.3.2.



Liberté • Egalité • Fraternité  
RÉPUBLIQUE FRANÇAISE

MINISTÈRE  
DE LA TRANSITION  
ÉCOLOGIQUE  
ET SOLIDAIRE

30



# Transport of LNG in bulk by Inland Waterways in membrane tanks - Conclusions and future steps

## Third issue

Subject to a positive answer to issues #1 and #2, the Safety Committee is invited to decide which of the option (or may be the options) it prefers among those described in paragraph 15 of the document ECE/TRANS/WP.15/AC.2/2018/35

## Fourth issue

As indicated in paragraph 17 of the document ECE/TRANS/WP.15/AC.2/2018/35, the outcome of the discussion related to the third issue could serve to elaborate updated “Terms of Reference” for the IWG’s work

Liberté • Egalité • Fraternité  
RÉPUBLIQUE FRANÇAISE

MINISTÈRE  
DE LA TRANSITION  
ÉCOLOGIQUE  
ET SOLIDAIRE

31



Thank you for your attention