

Distr.: Restricted
26 July 2018
English
Original: English, French and
Russian

Working Party on Inland Water Transport

Sixty-second session

Geneva, 3-5 October 2018

Item 6 (b) of the provisional agenda

Standardization of technical and safety requirements in inland navigation:

Signs and Signals on Inland Waterways (SIGNI)

(Resolution No. 22, revision 2)

Annex to Resolution No. ... SIGNI: European Code for Signs and Signals on Inland Waterways (Appendices)*

A. Appendix 1

Minimal dimensions of the signs from annexes 7 and 8 of the European Code for Inland Waterways

1. Visibility of signs

Guidance on the maximum distances at which the various signs are visible is given in the figure 1.^{1, 2} The distances are valid for boards with dimensions of 100 cm x 100 cm and 150 cm x 100 cm, with the observer positioned at a right angle to the surface of the board. When using boards of other dimensions, the distance at which the sign is visible should be recalculated according to the chosen scale.

* Annex is available in Informal document SC.3 No. 2 (2018).

¹ Etude de la perceptibilité des symboles et des inscriptions sur les signaux de navigation (Study of symbol and inscription visibility on navigation signs), Gerdes, presented at the 1990 International Conference on Maritime Signs.

² This publication is referred to in the IALA Guideline No. 1094 On Daymarks for Aids to Navigation, Edition 1, December 2012.

Sign images:

Figure 1

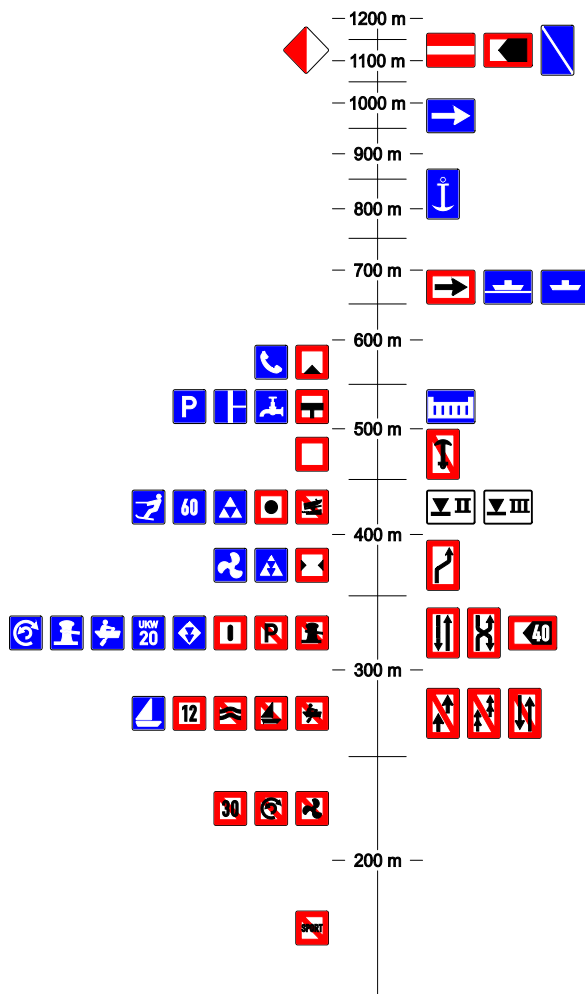

Characters:

For many types of European characters (e.g. DIN 1451), when using black type on a white background, the maximum readability distance D — if the observer is positioned at a right angle to the surface of the board — is approximately $D \approx 465 h$, where h equals the height of the character (height of capital letters above the line).

Viewed at an angle:

If seen askew (see fig. 2), the maximum visibility or readability distance of the board is reduced each time by the cosine of angles h and v between the observer and the central perpendicular line: $D(h, v) = D_o \cos(h) \cos(v)$.

Figure 2

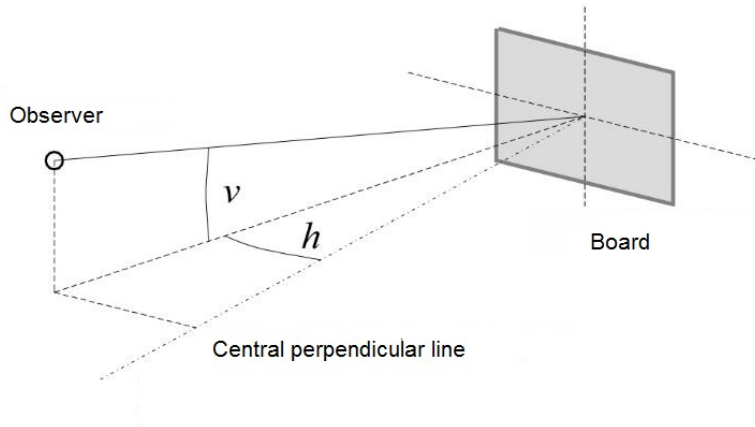

When the observer is at a great distance (see fig. 3), the vertical angle shall be considered to be approximately 0: $v \approx 0$. In such cases, the following formula can be used as guidance to determine the visibility distance: $D(h, v) \approx D(h) = D_0 \cos(h)$. The area of visibility is thus a circle with a diameter of D_0 .

Figure 3

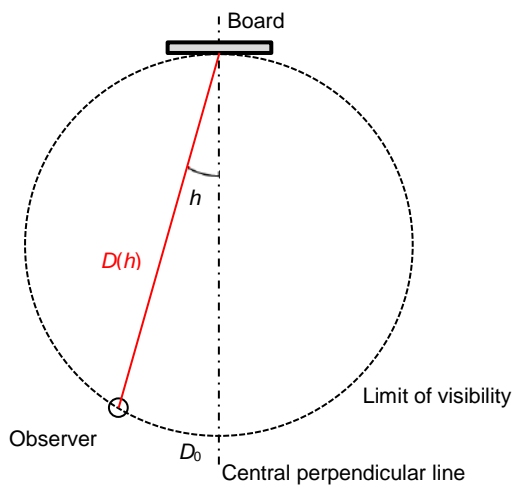

2. Minimal dimensions of the signs contained in annex 7 to the European Code for Inland Waterways

2.1 Main signs

A. Prohibitory signs

A.1 No entry

A.1a Board

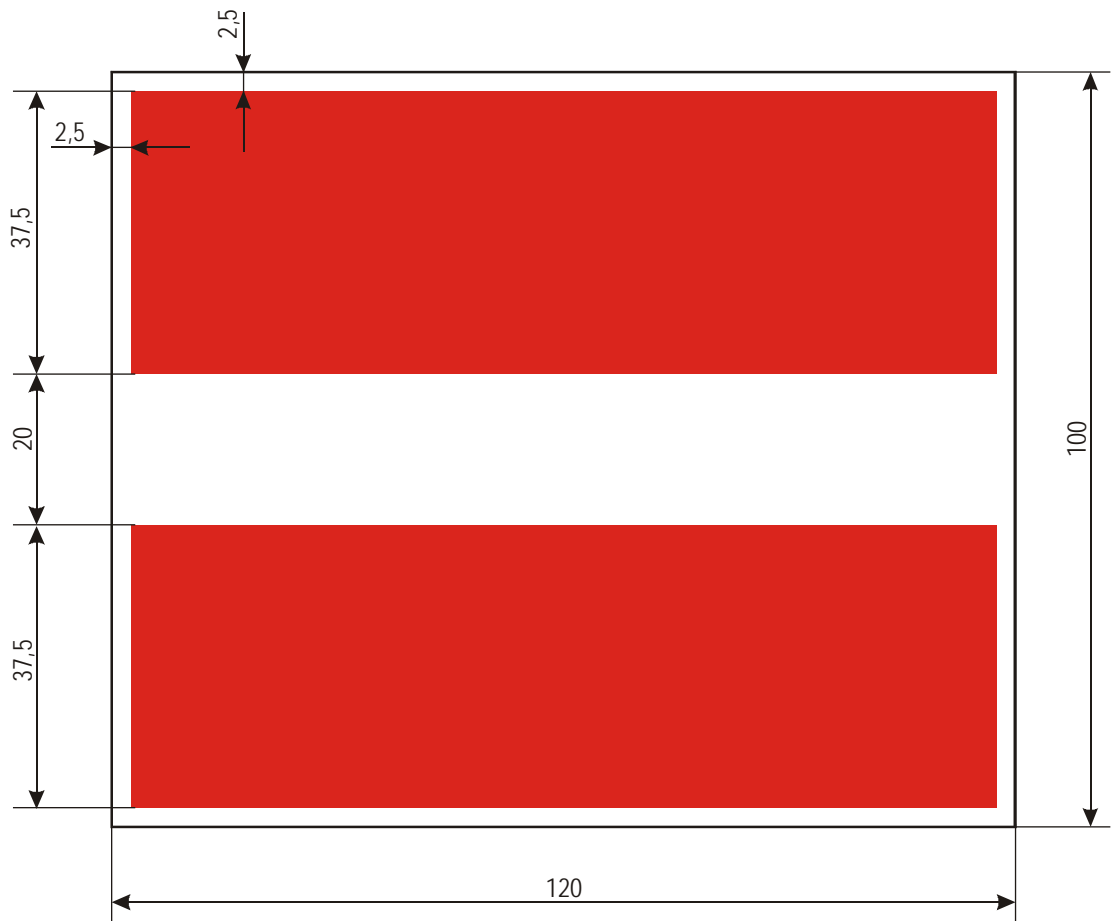

A.1.1 Sections closed to use, no entry except for non-motorized small craft

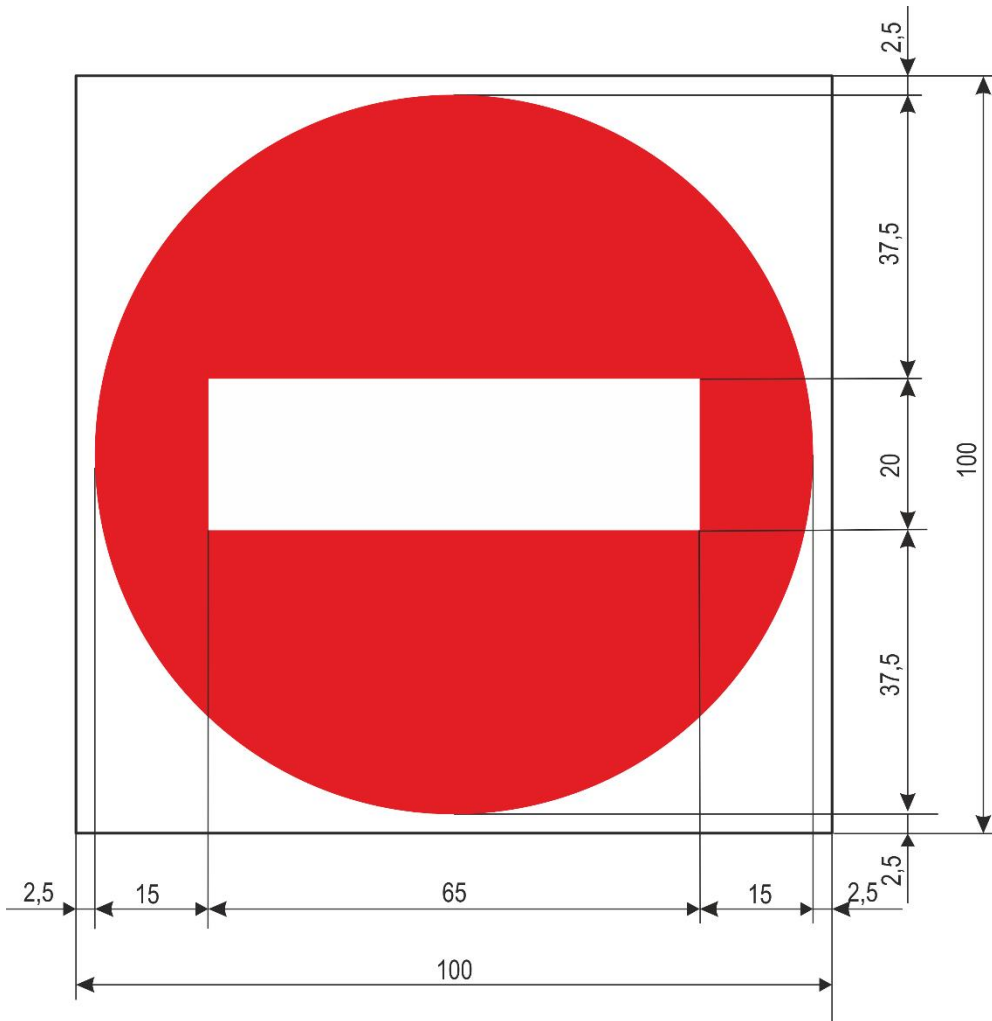

A.2 No overtaking

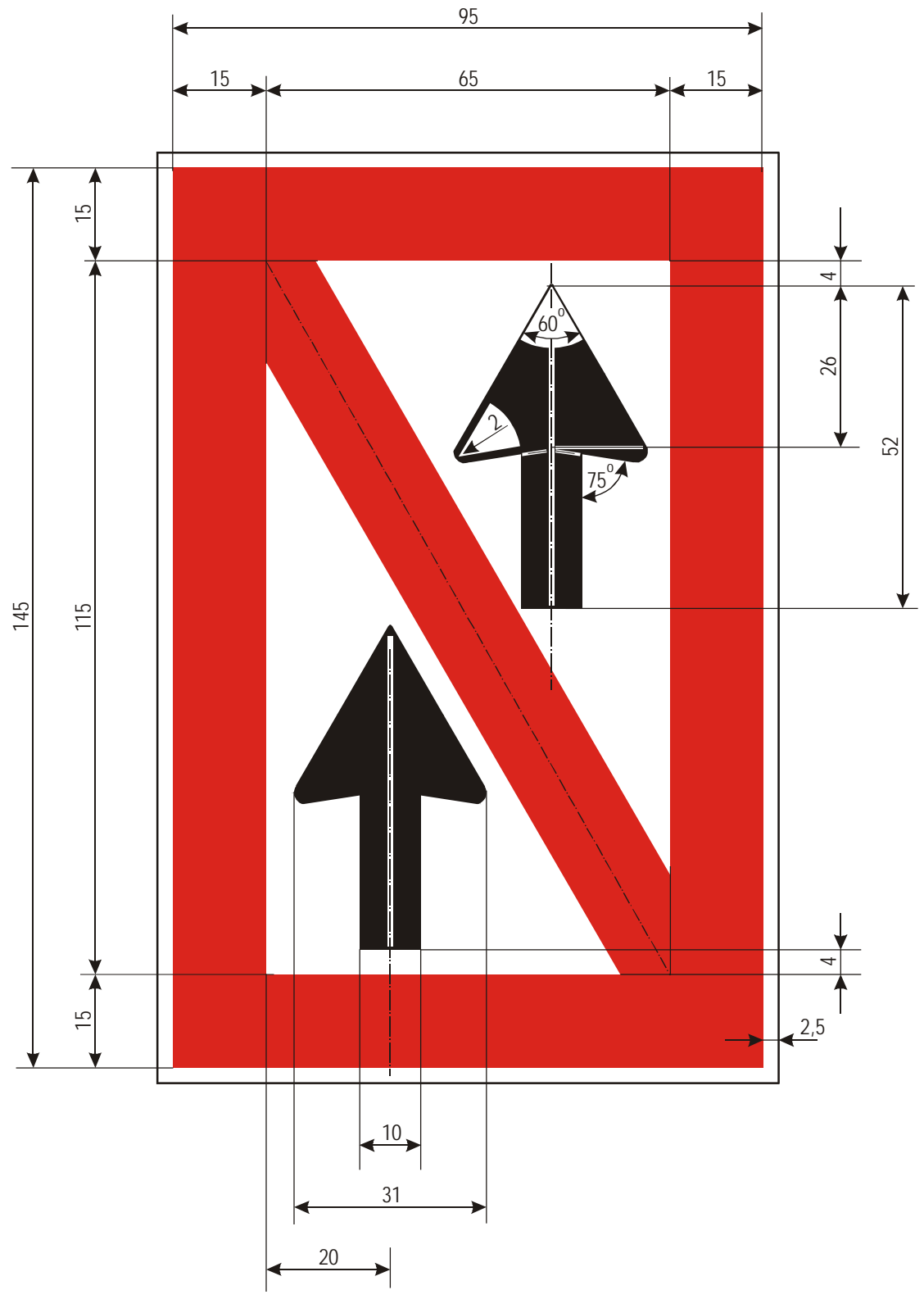

A.3 No overtaking of convoys by convoys

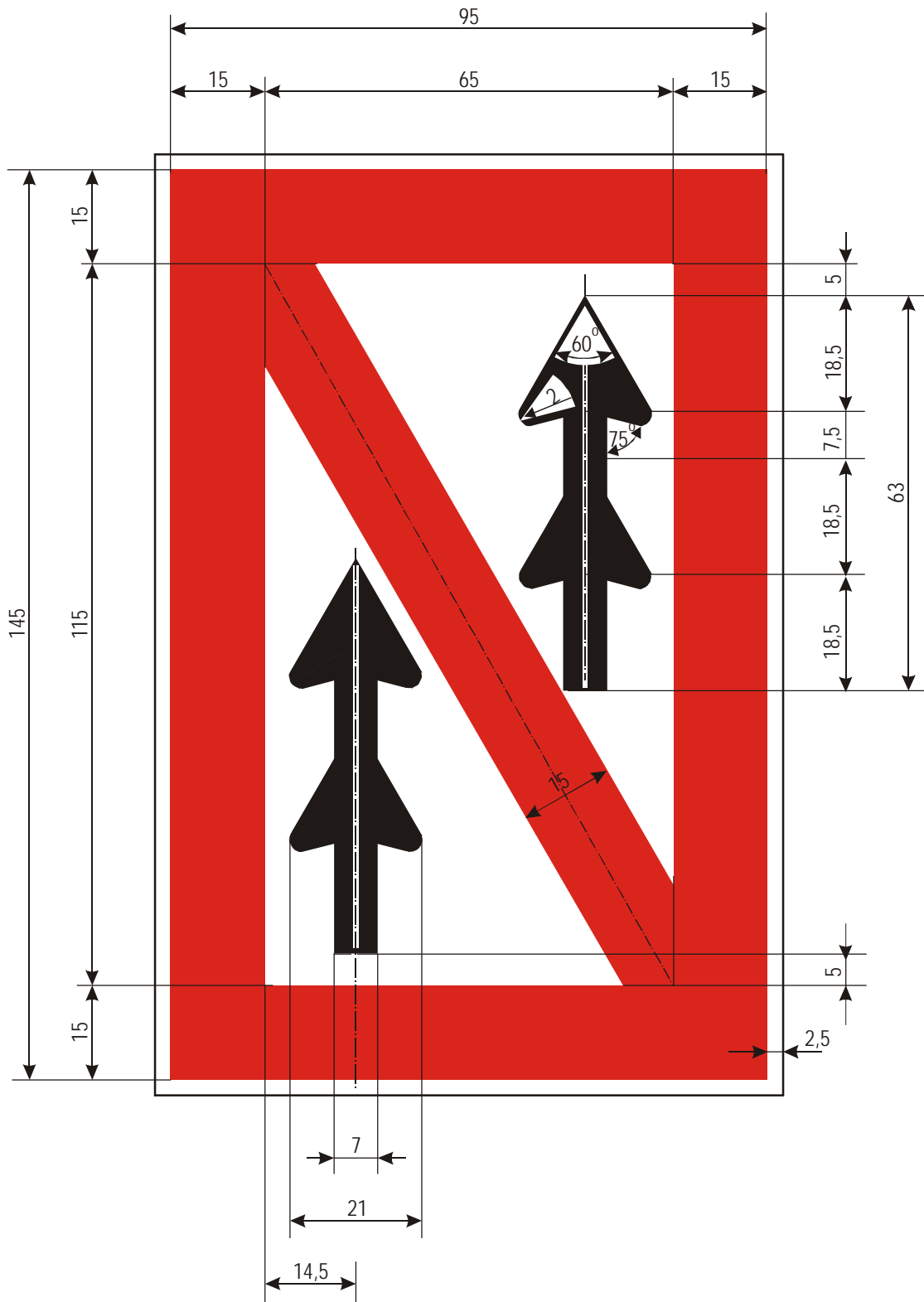

A.4 No passing or overtaking

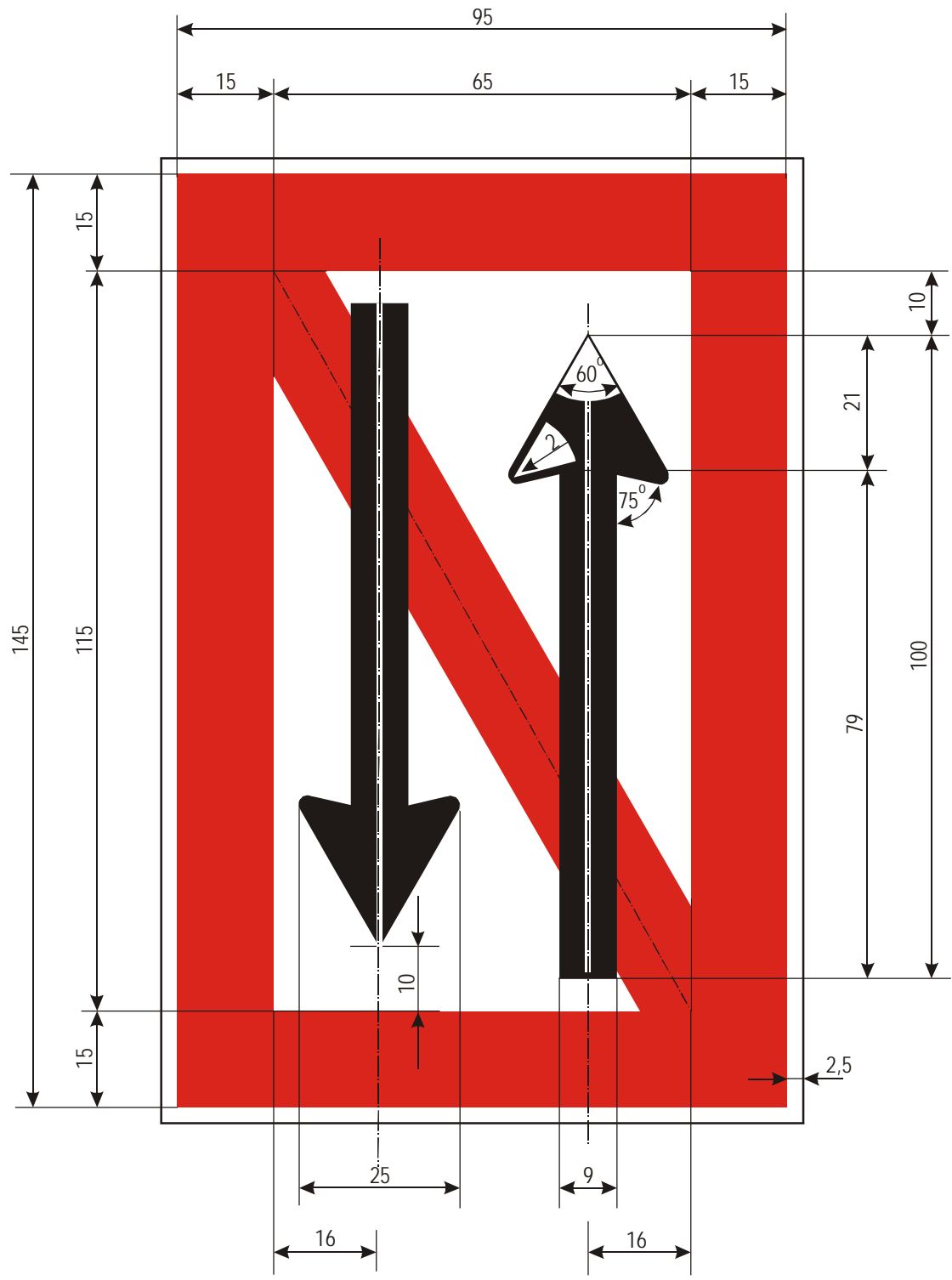

A.5 No berthing on the side of the waterway on which the sign is placed
(i.e. no anchoring or making fast to the bank)

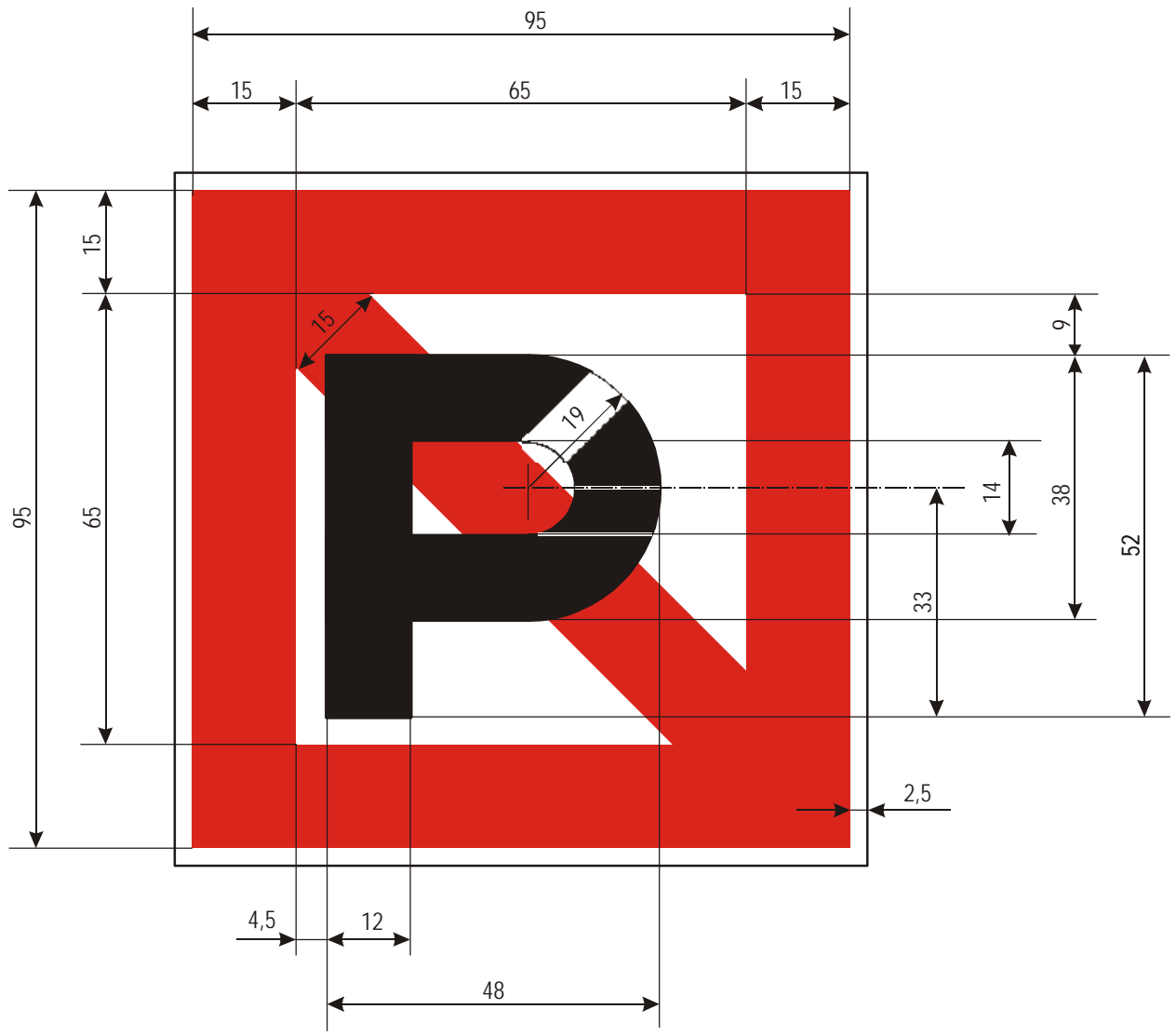

A.5.1 No berthing on the stretch of water whose breadth, measured from the sign, is shown in metres on the sign

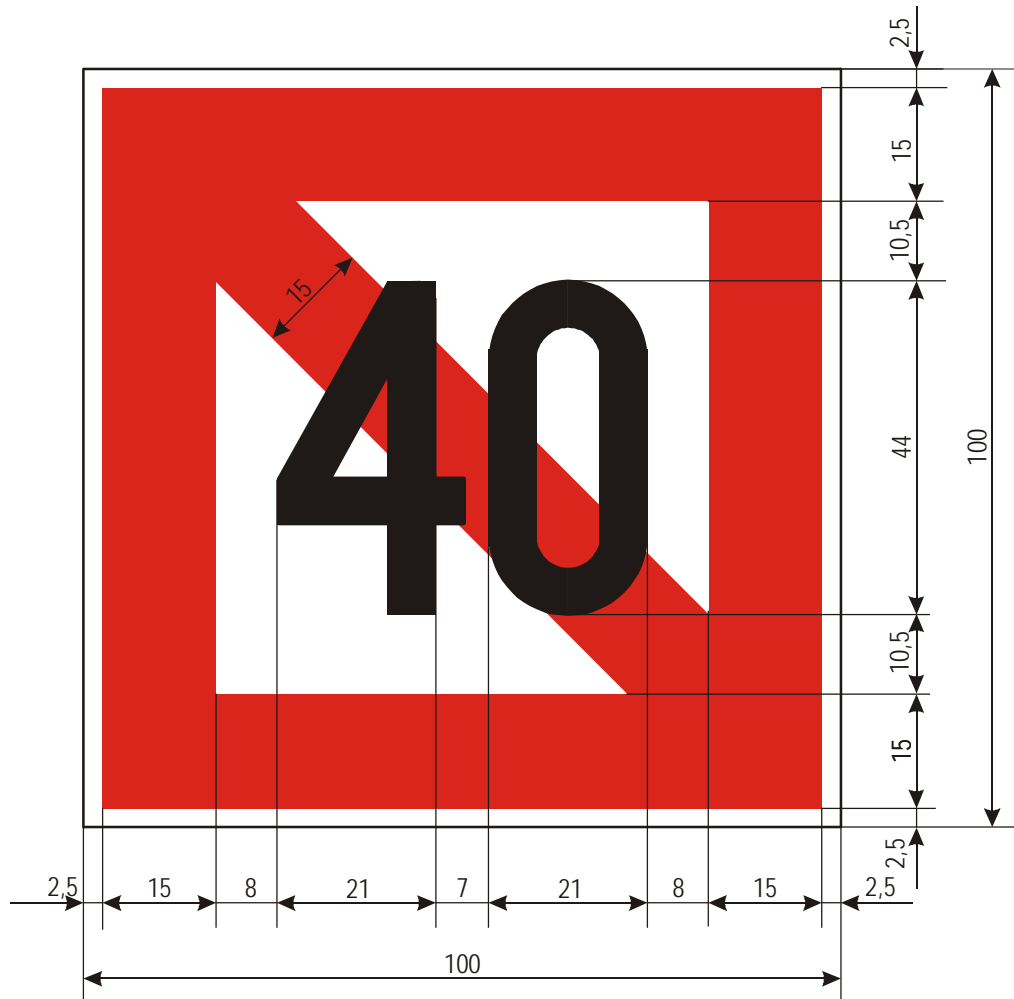

A.6 No anchoring or trailing of anchors, cables or chains on the side of the waterway on which the sign is placed

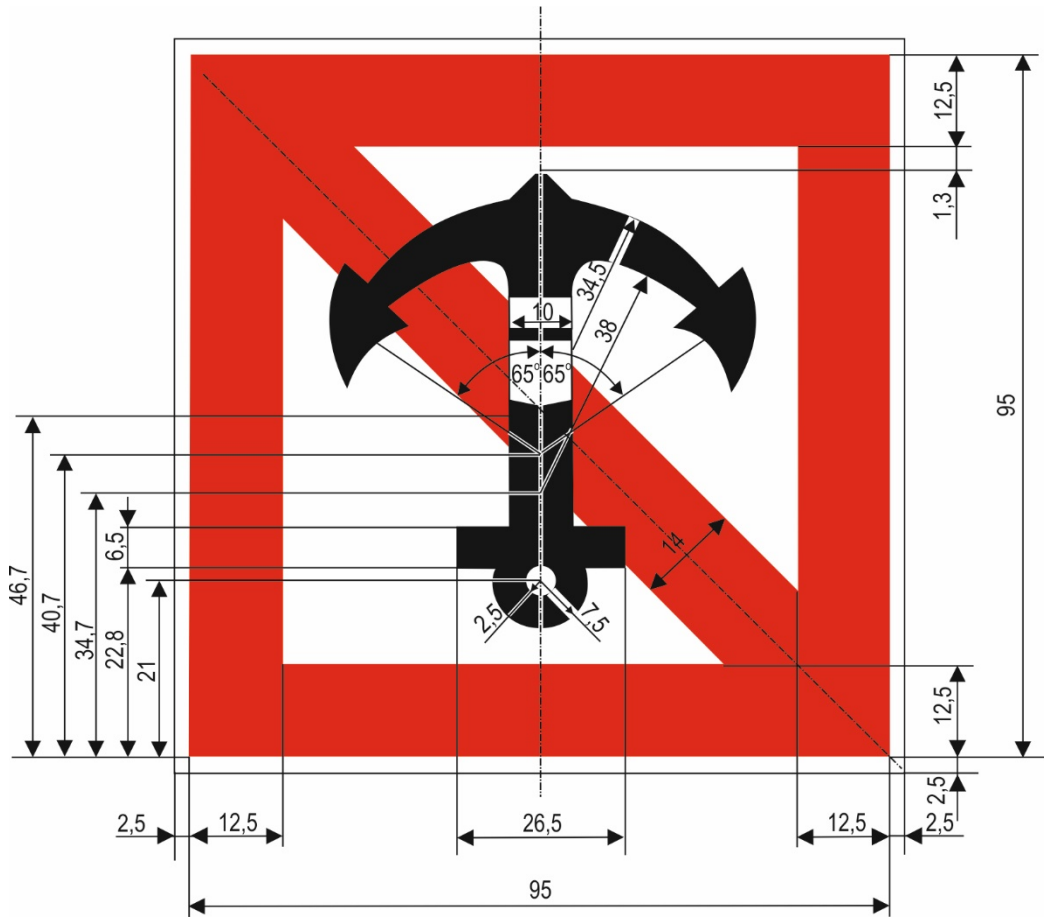

A.7 No making fast to the bank on the side of the waterway on which the sign is placed

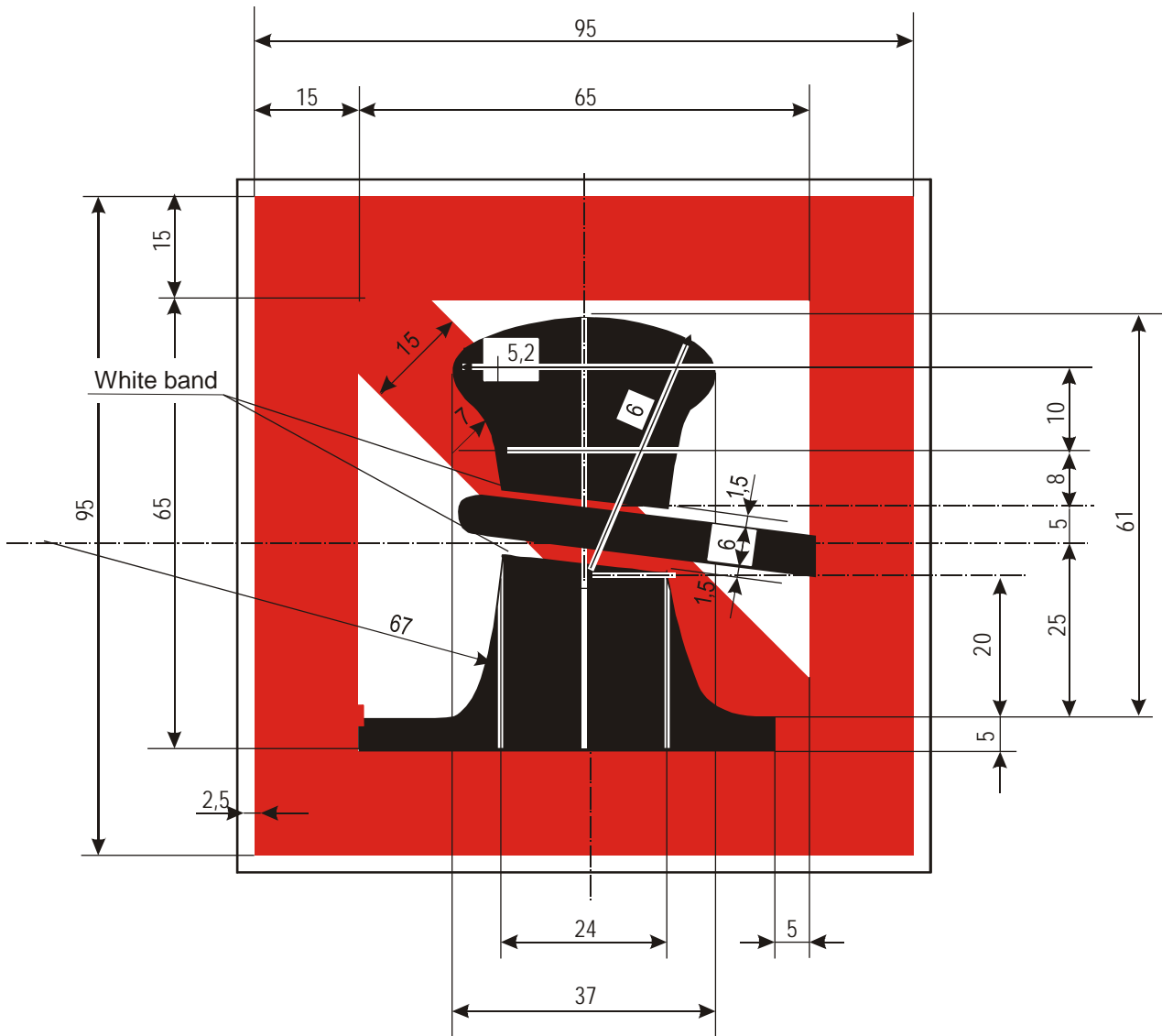

A.8 No turning

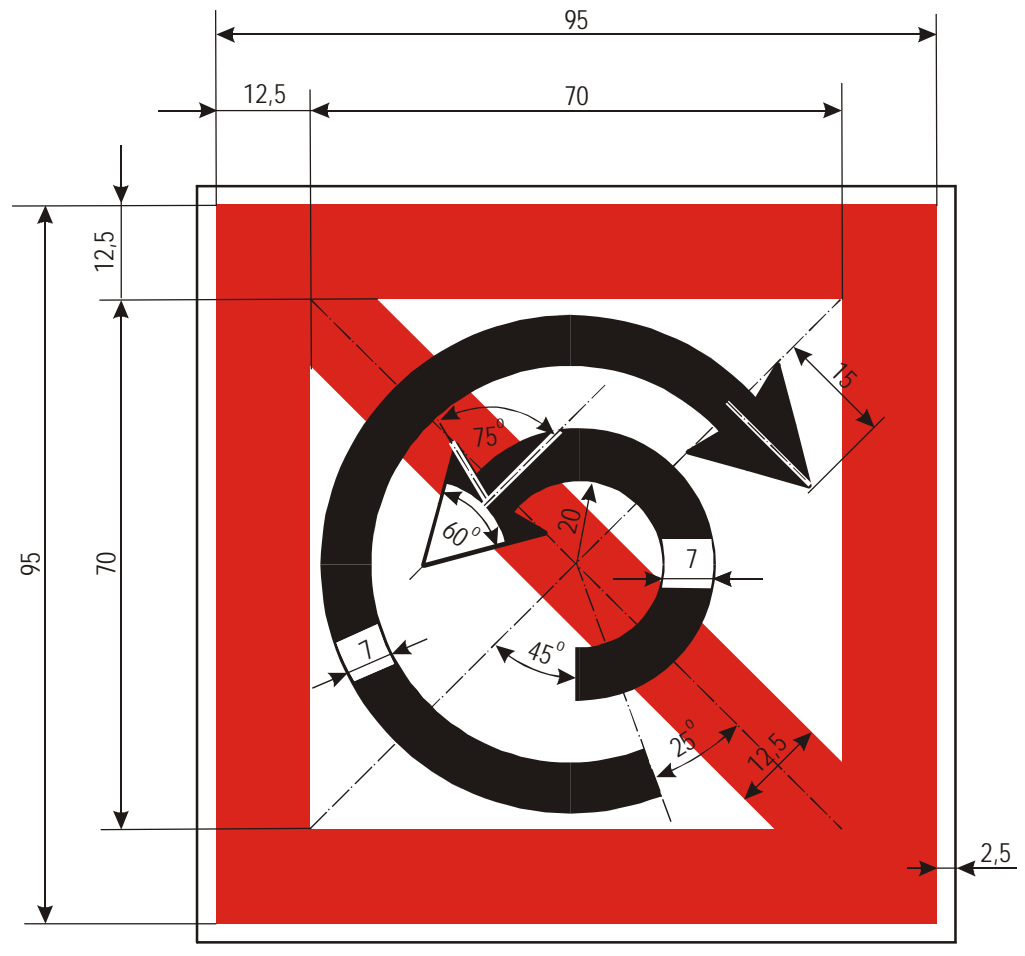

A.9 Do not create wash likely to cause damage

A.9a

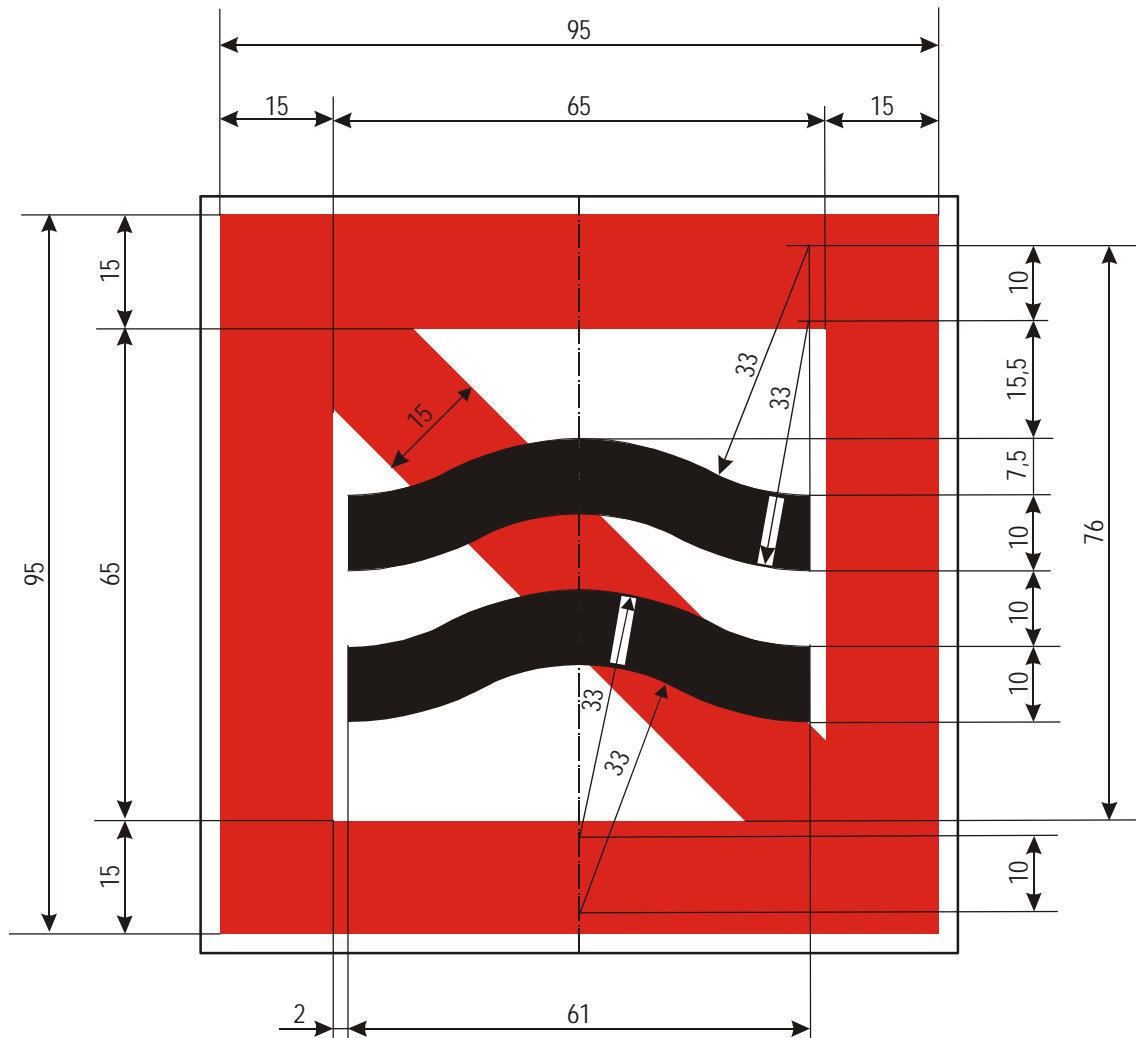

A.10 No passing outside the area marked (in openings of bridges or weirs)

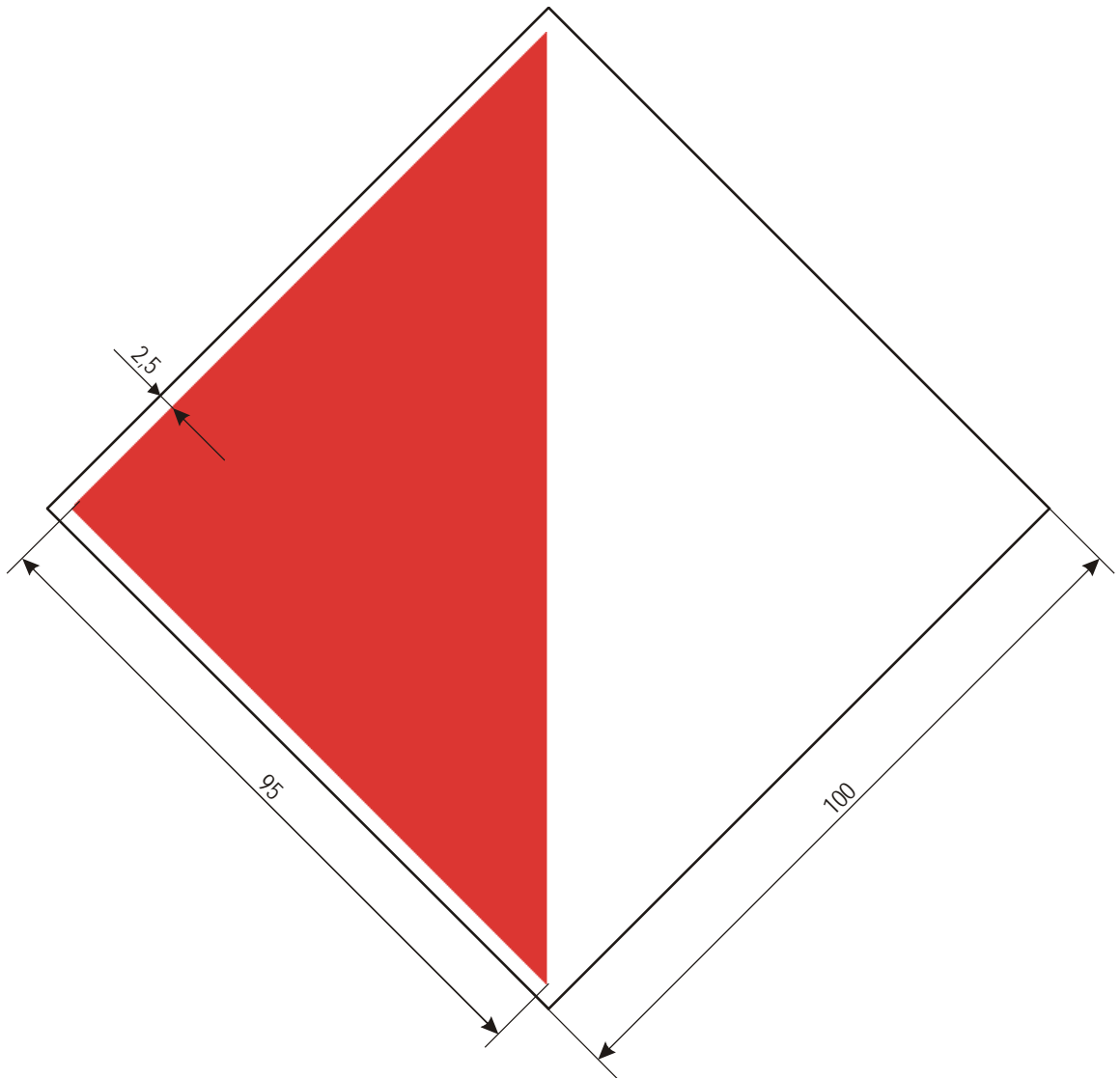

A.12 Motorized craft prohibited

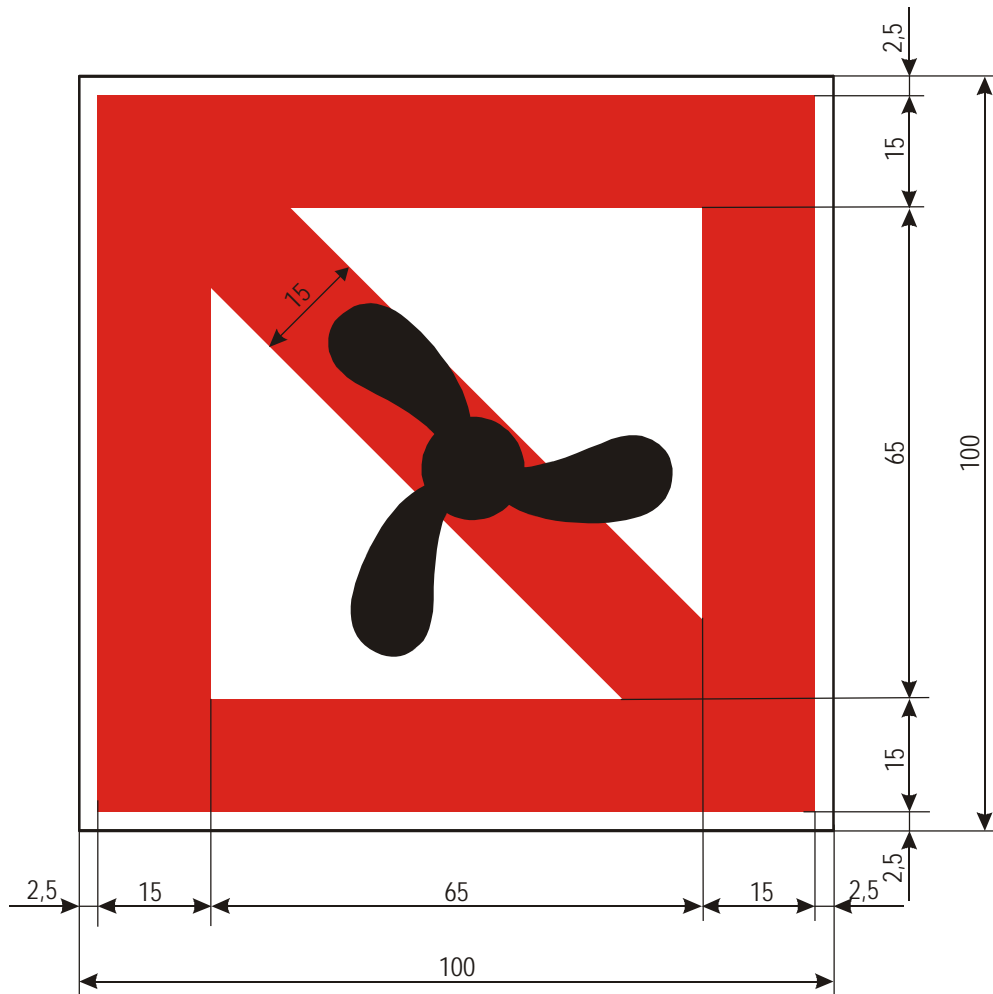

A.14 Water skiing prohibited

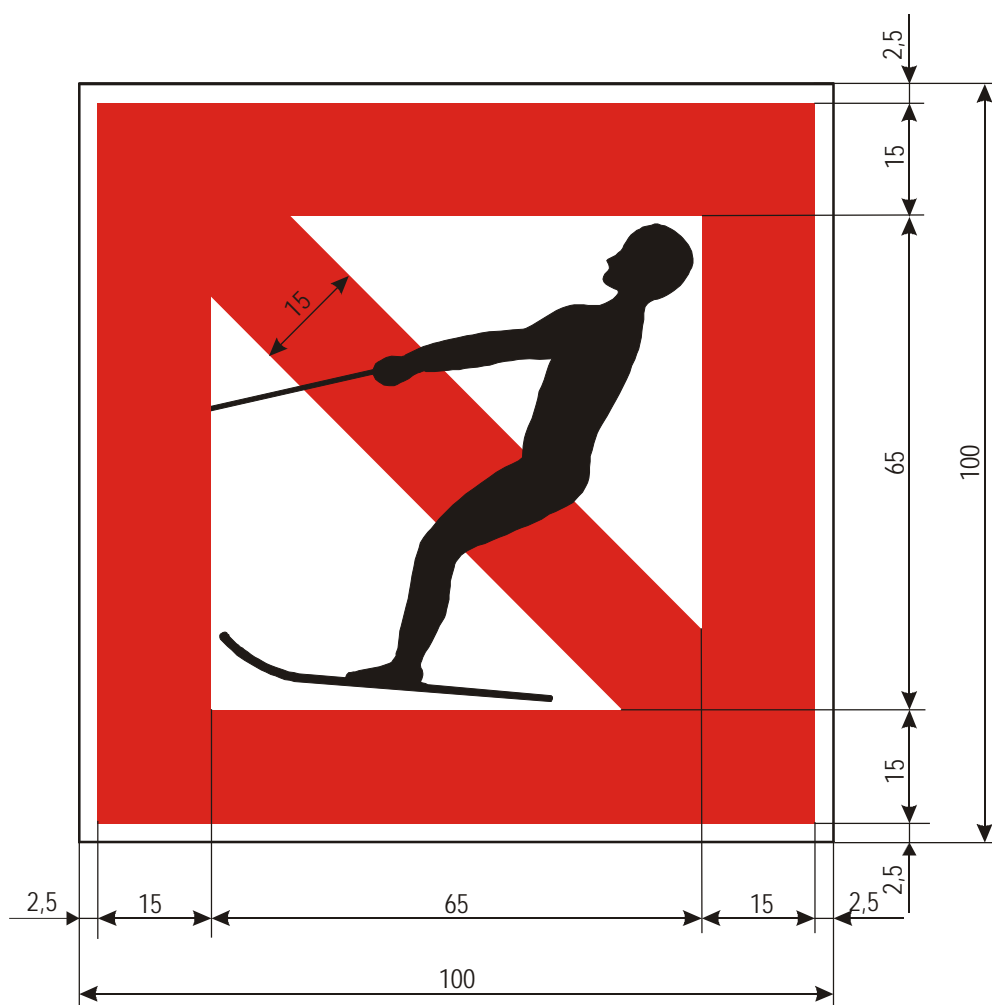

A.15 Sailing vessels prohibited

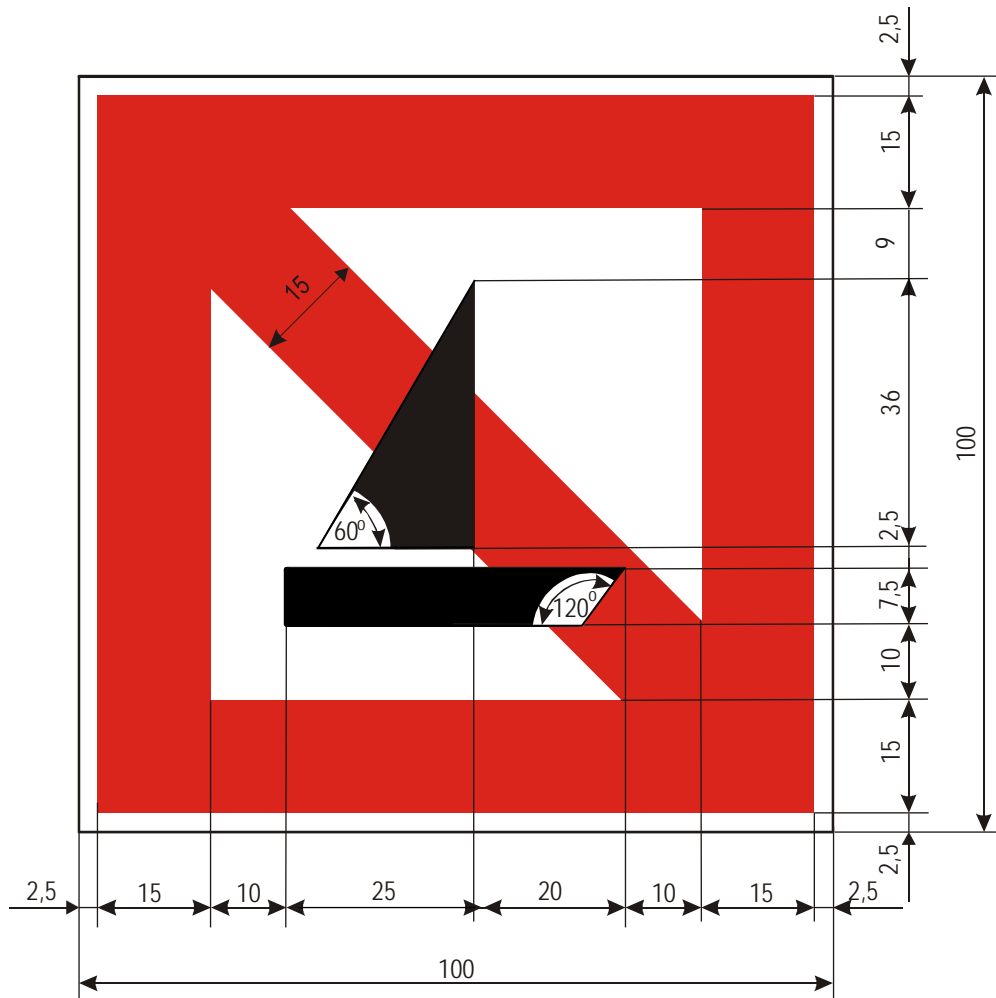

A.17 Use of sailboards prohibited

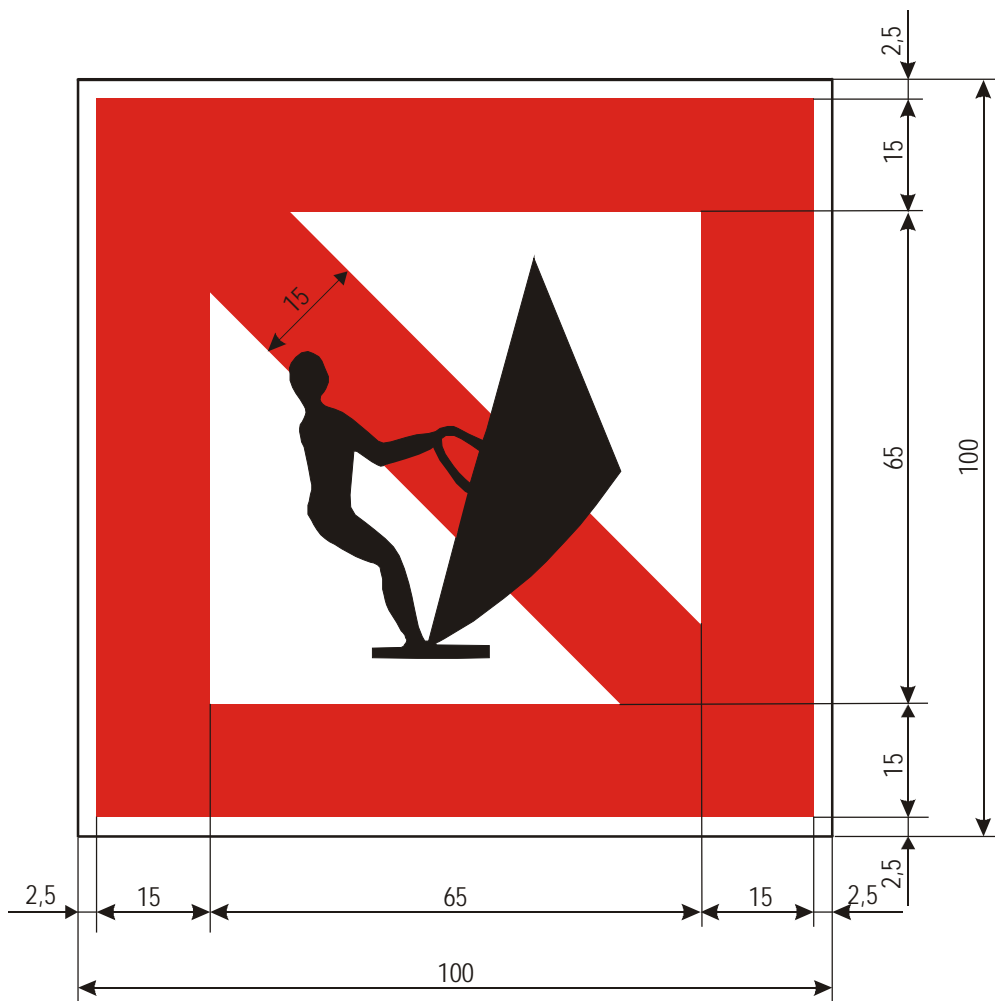

A.18 End of zone authorized for high speed navigation of small sport and pleasure craft

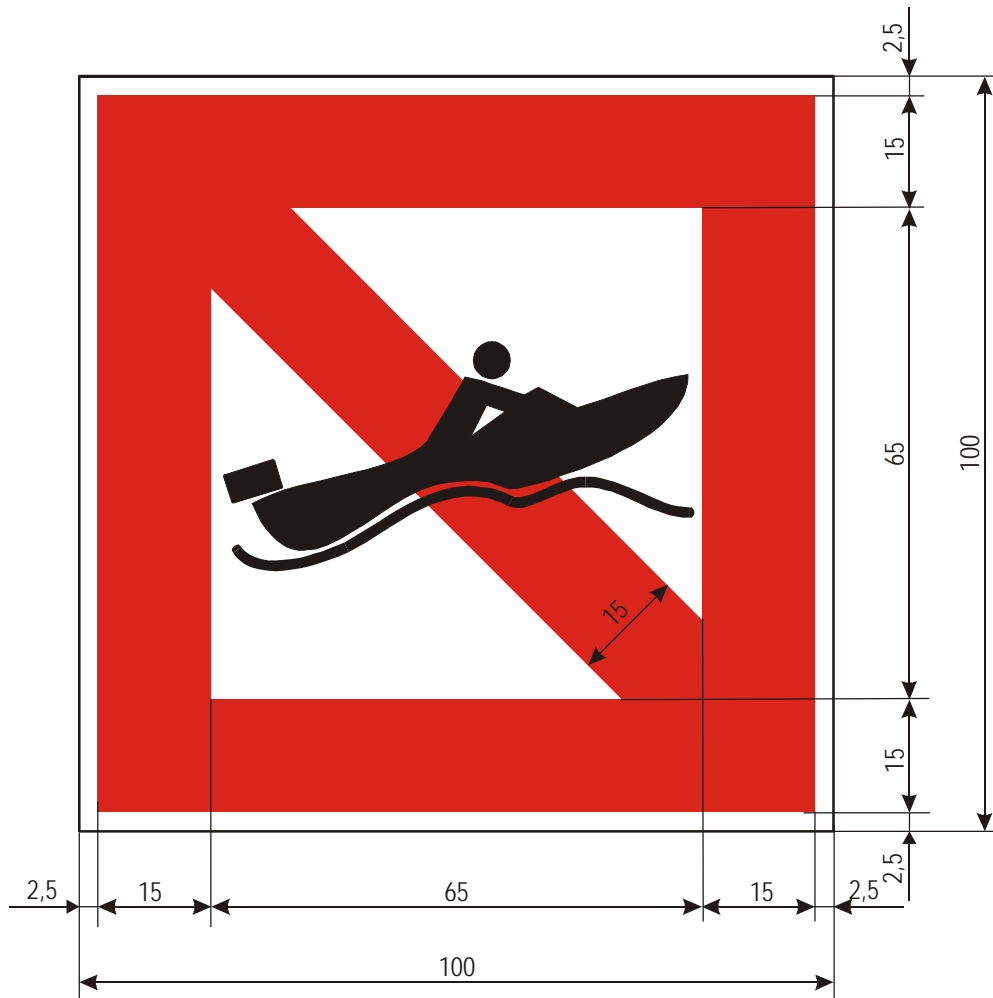

A.19 No launching or beaching of vessels

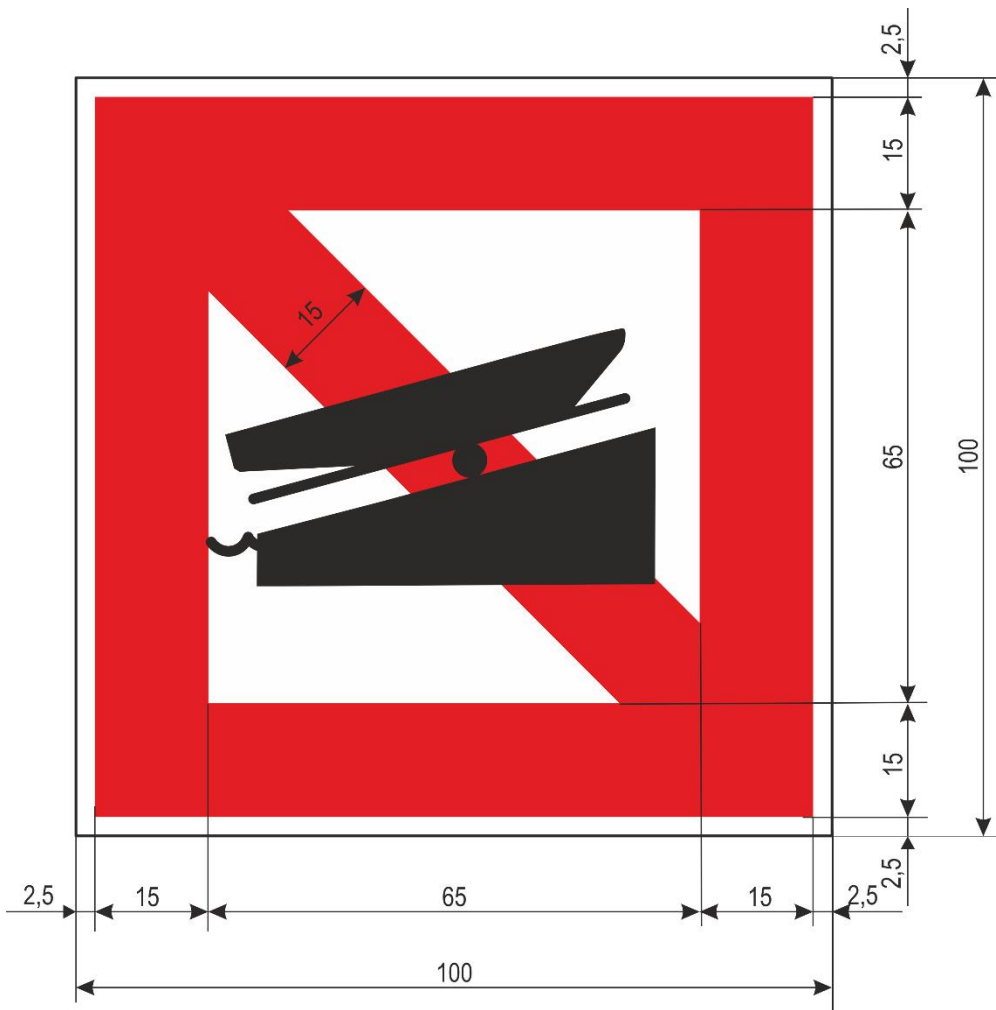

A.20 Water bikes prohibited

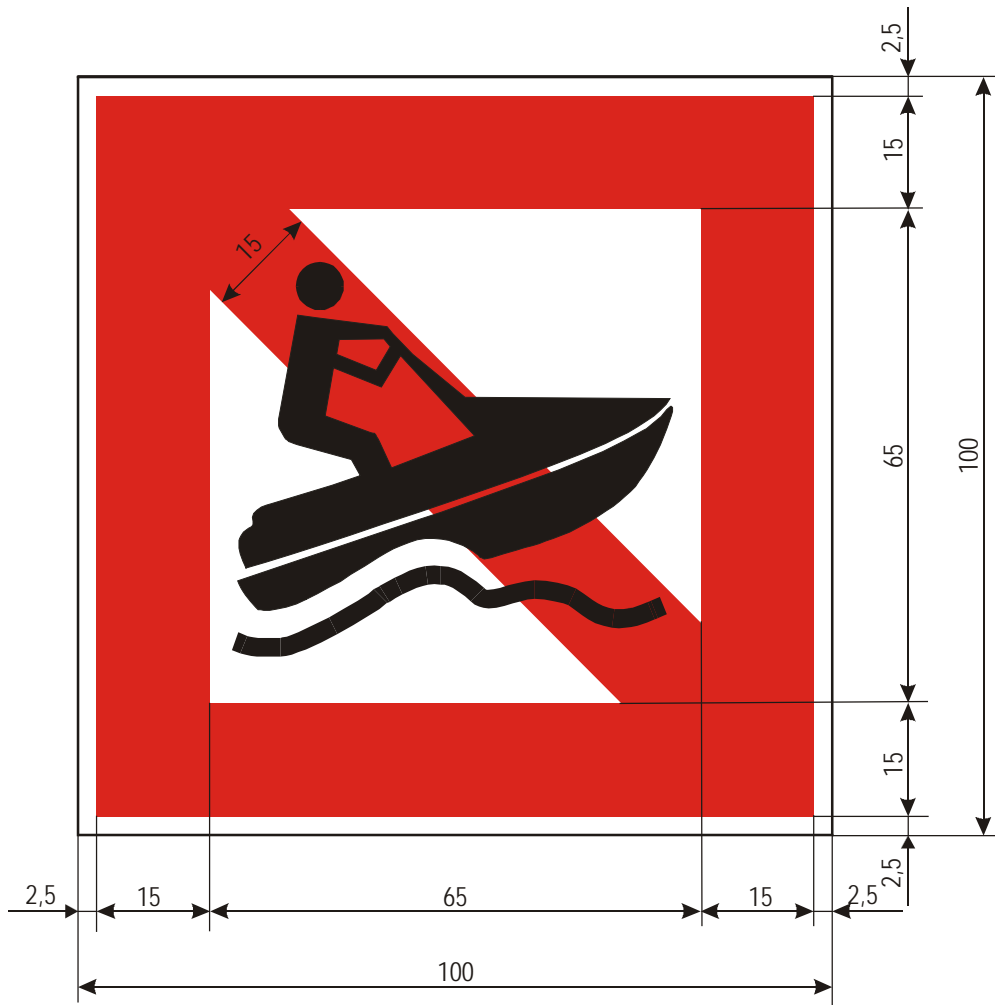

B. *Mandatory signs*

B.1 Proceed in the direction shown by the arrow

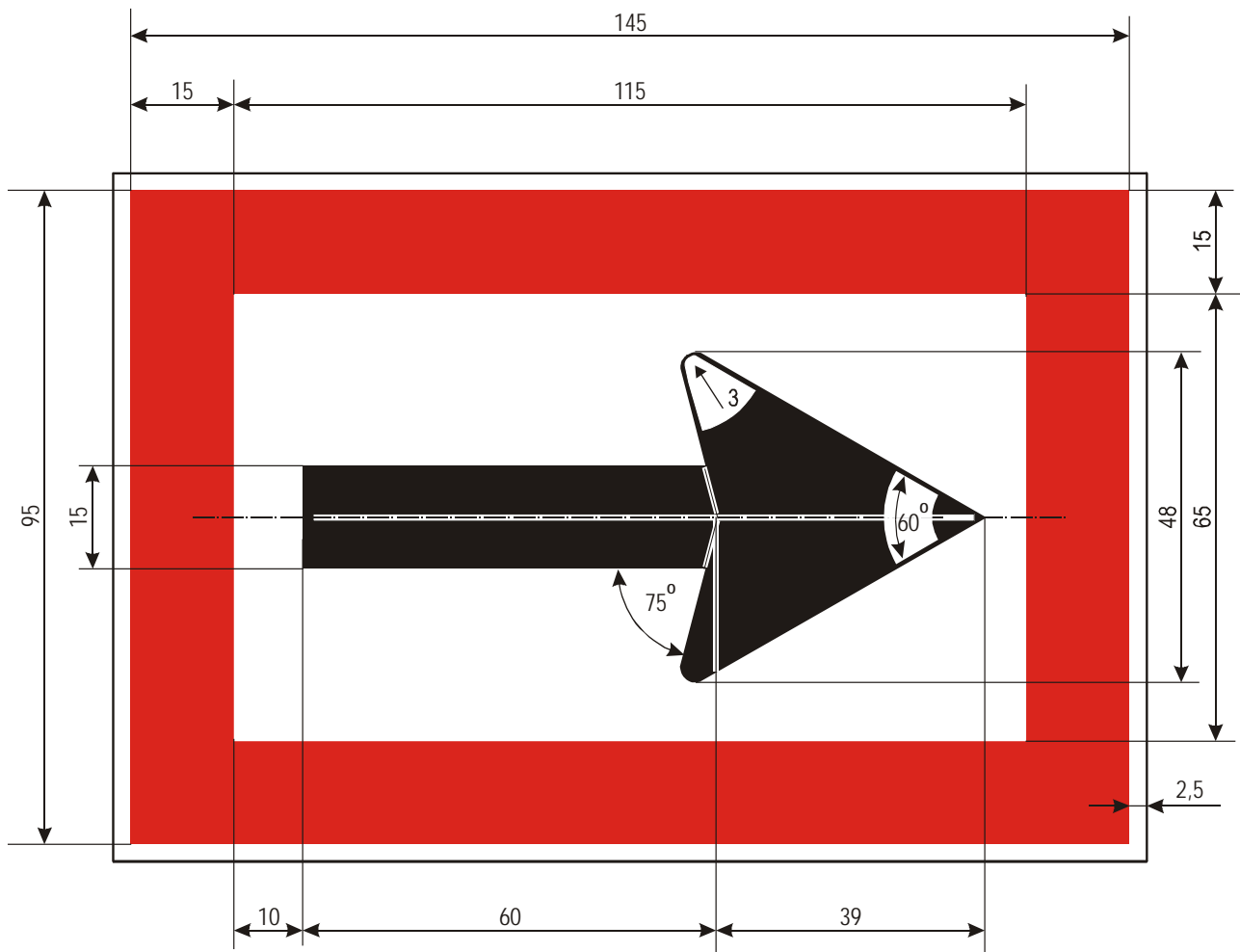

B.2a Move to the side of the fairway on your port side

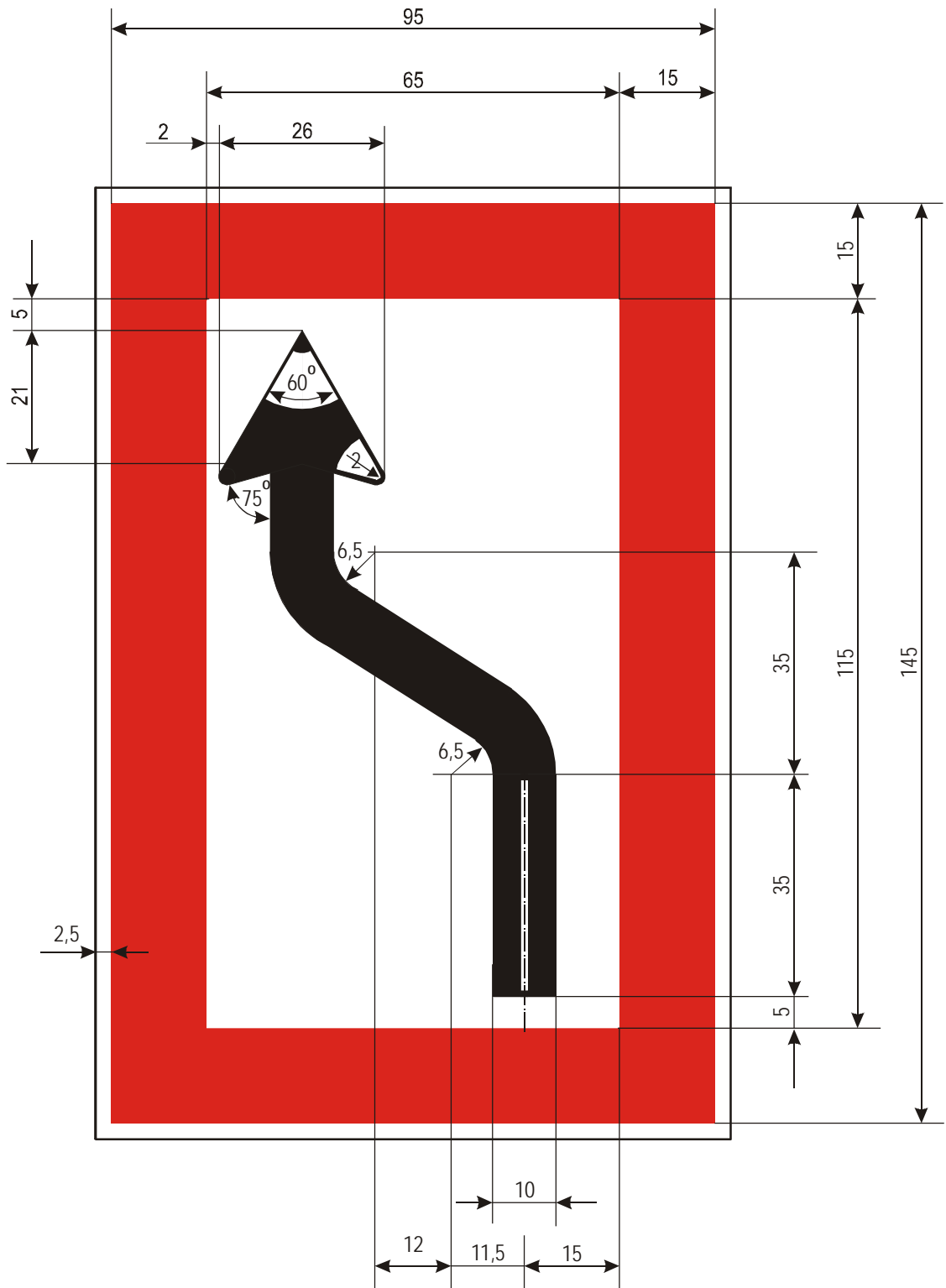

B.2b Move to the side of the fairway on your starboard side

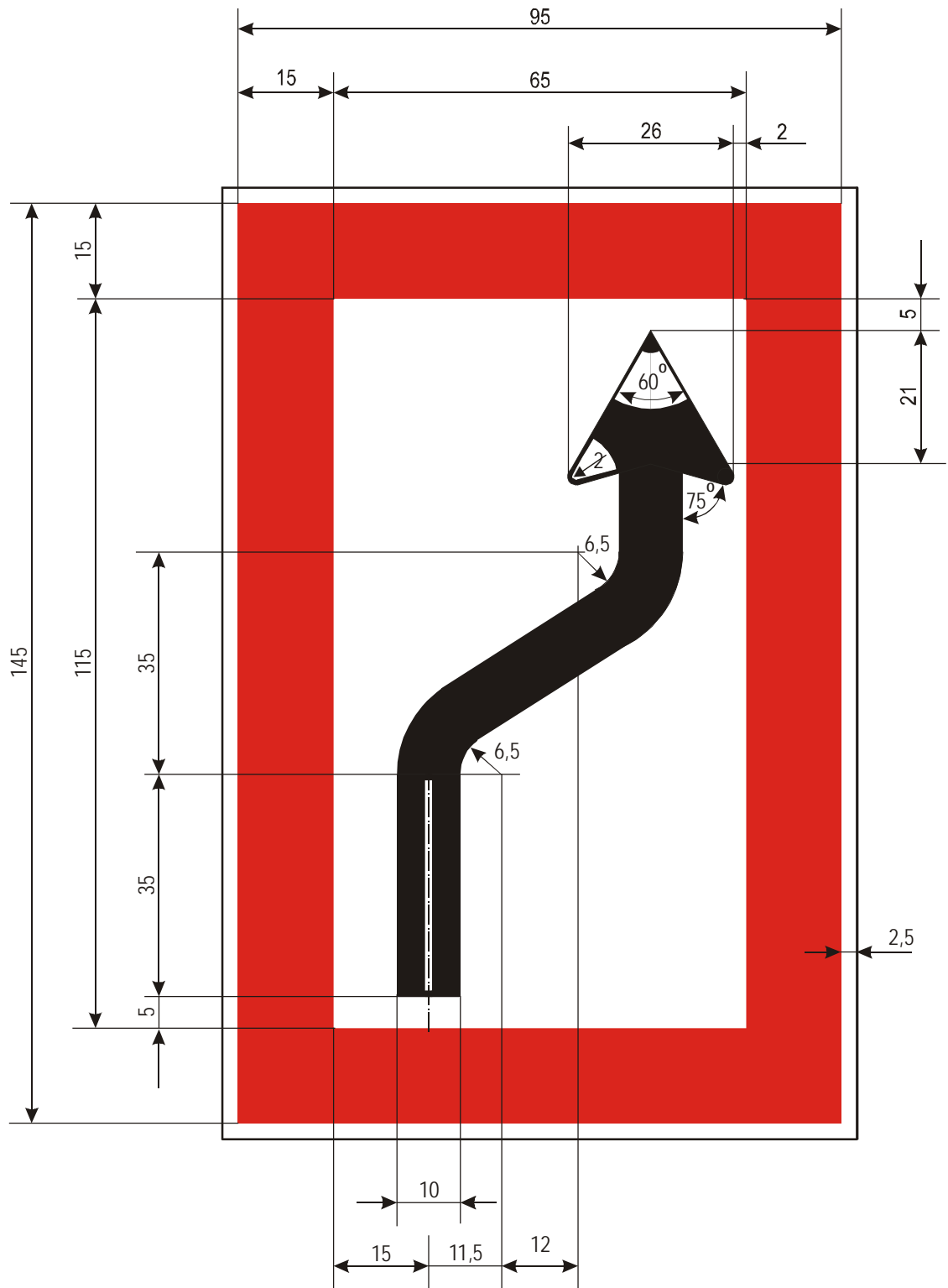

B.3a Keep to the side of the fairway on your port side

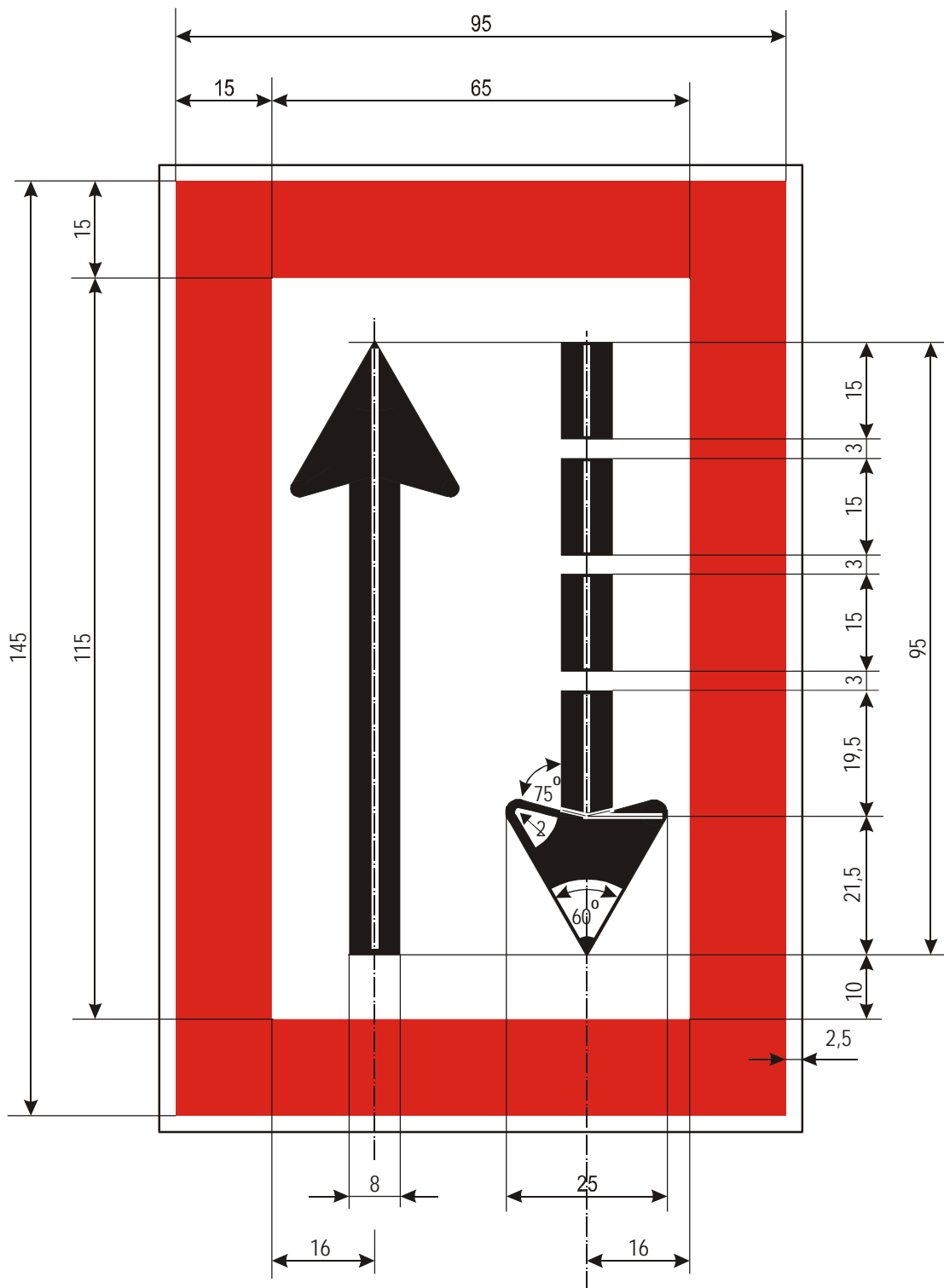

B.4a Cross fairway to port

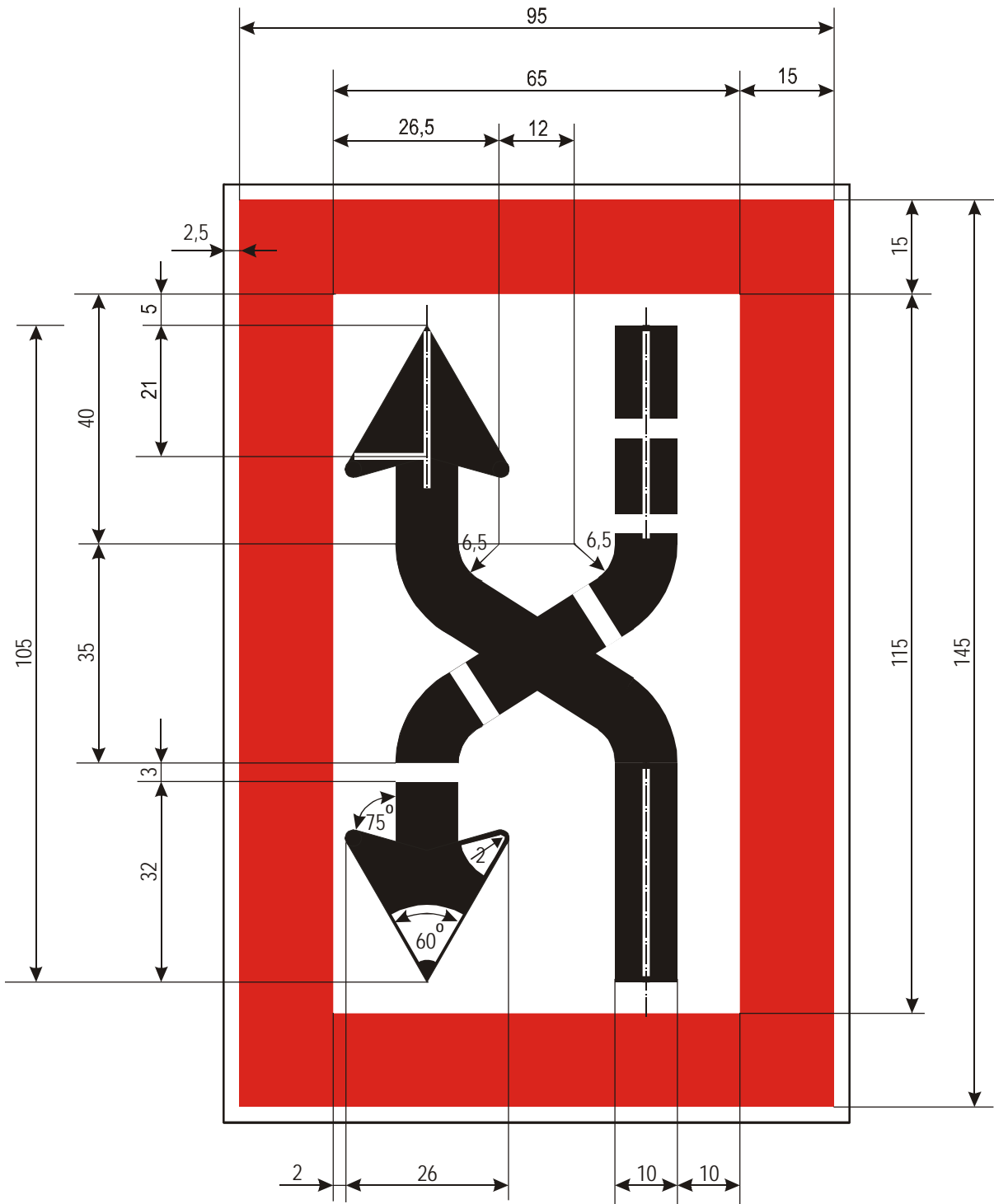

B.5 Stop as prescribed in the Regulations (see article 6.26, para. 2 and article 6.28, para. 1 of CEVNI)

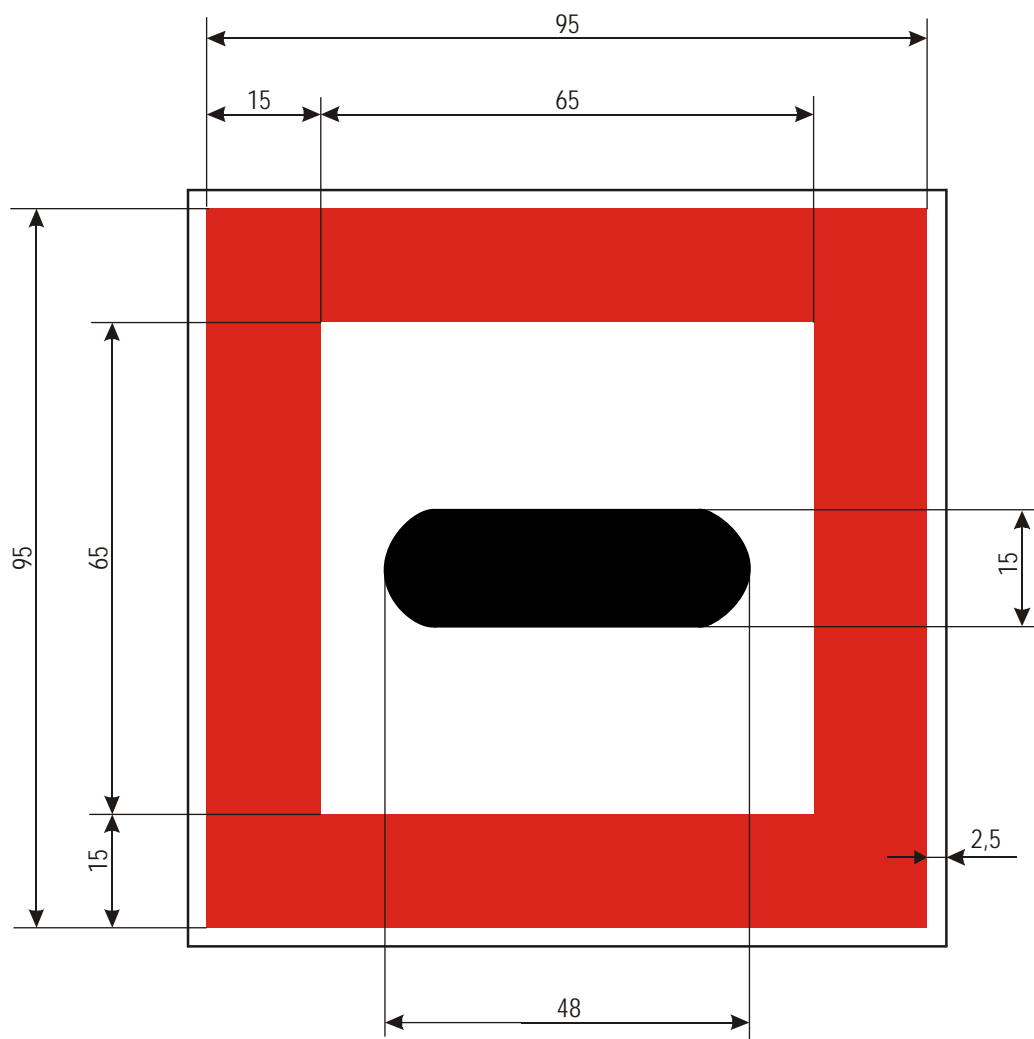

B.6 Do not exceed the speed indicated (in km/h)

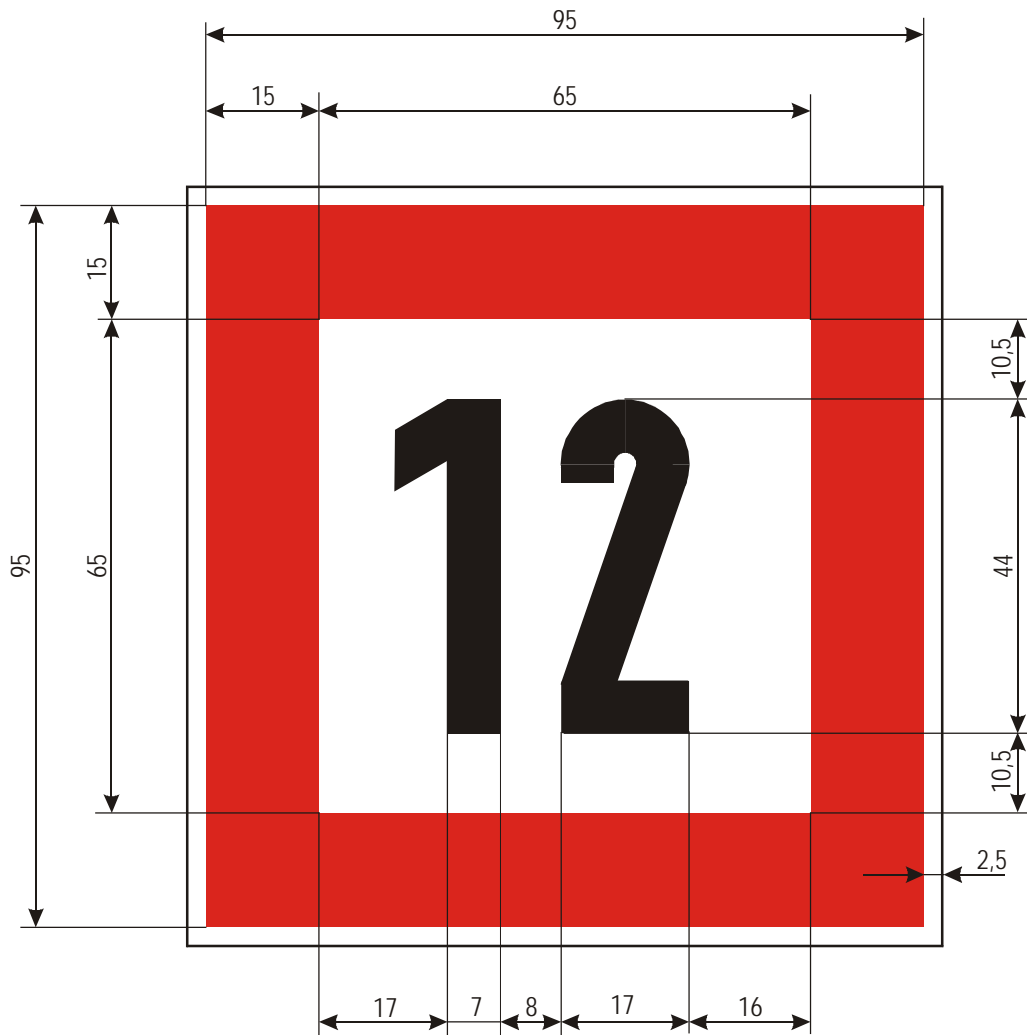

B.7 Give a sound signal

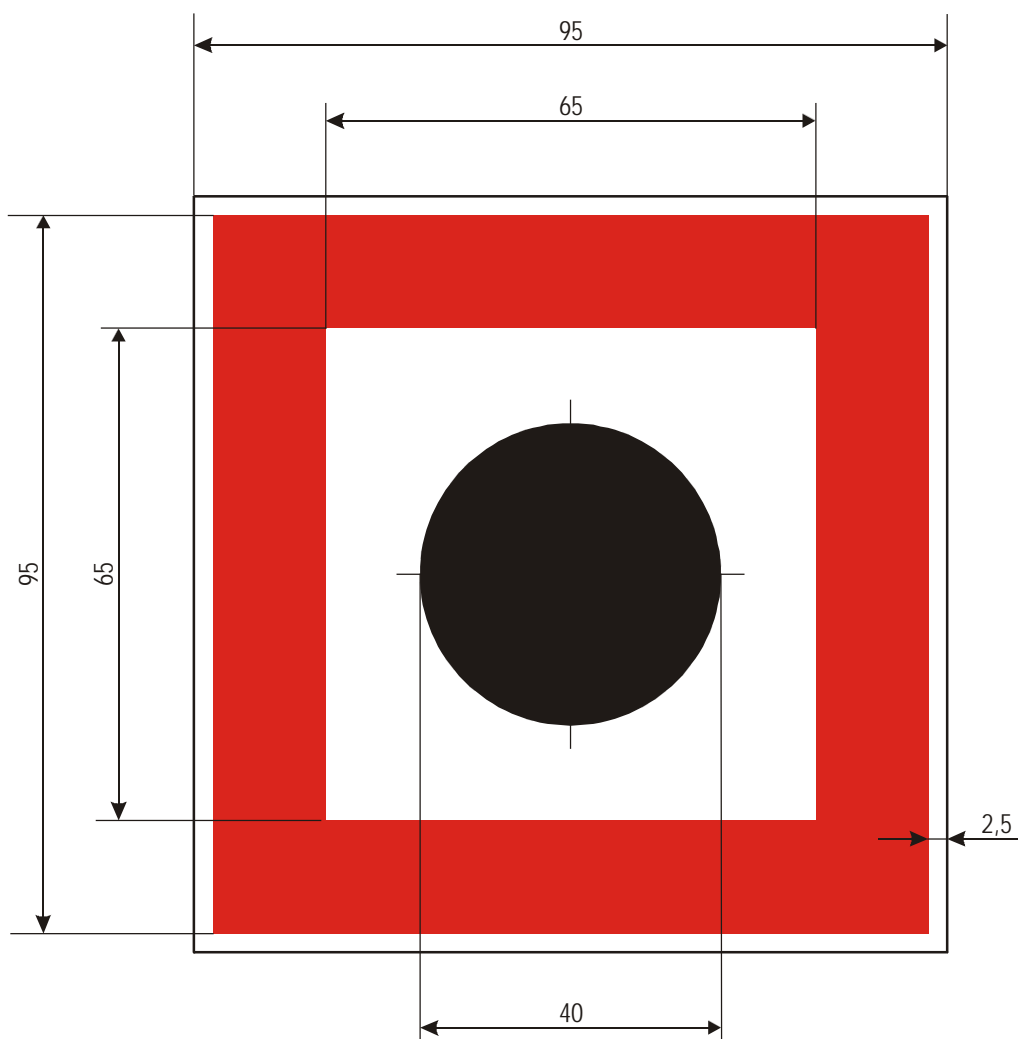

B.8 Keep a particularly sharp lookout

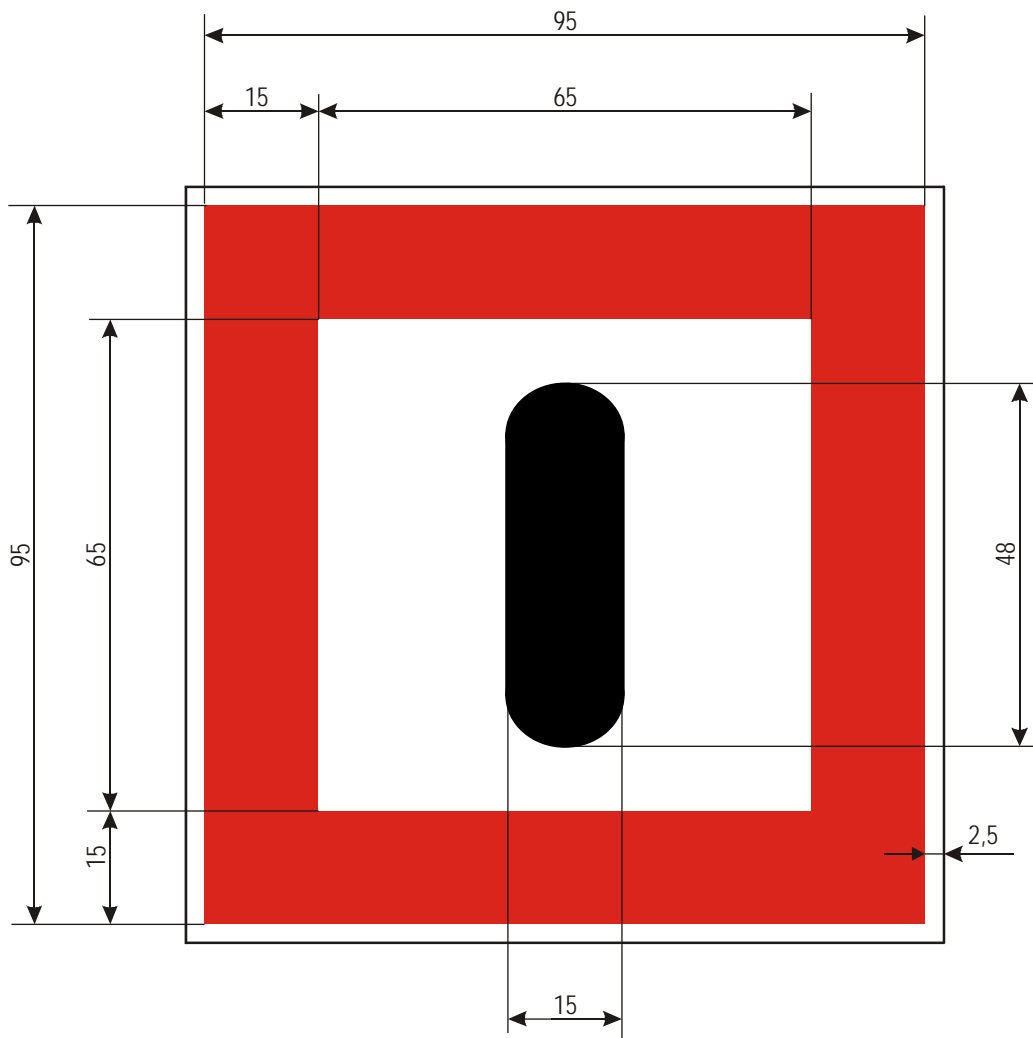

B.9a Do not enter the main waterway until certain that this will not oblige vessels proceeding on it to change their course or speed

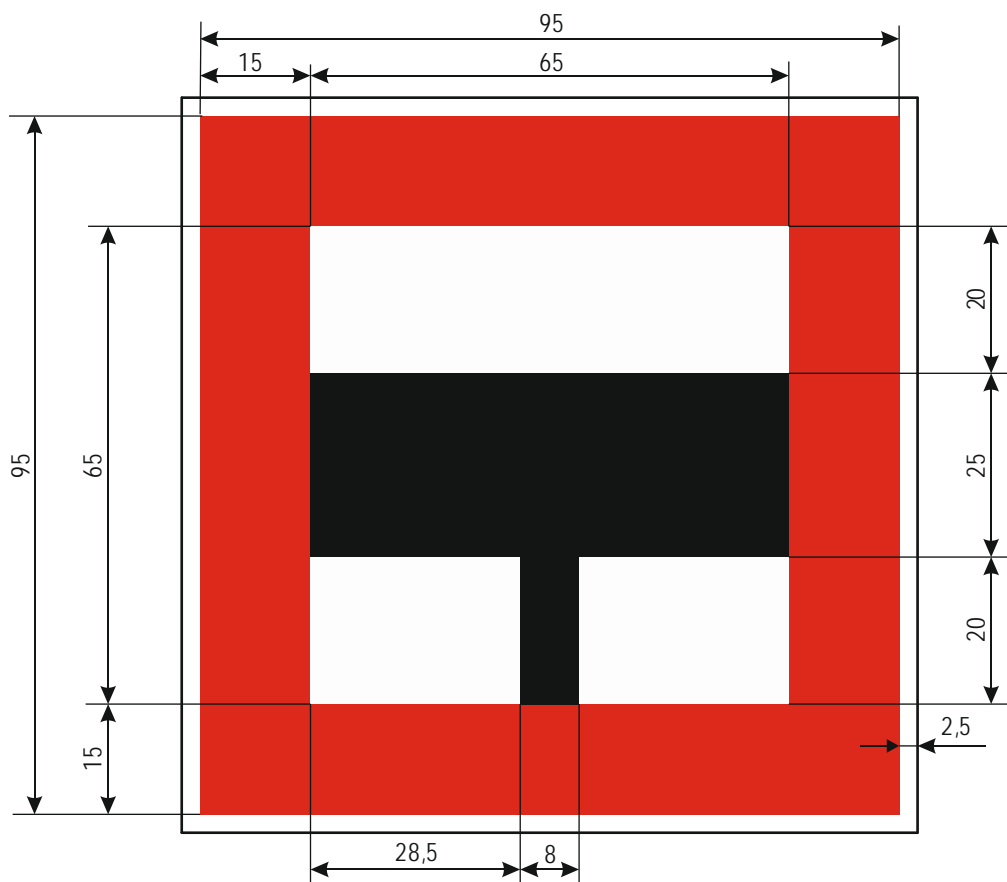

B.9b Do not cross the main waterway until certain that this will not oblige vessels proceeding on it to change their course or speed

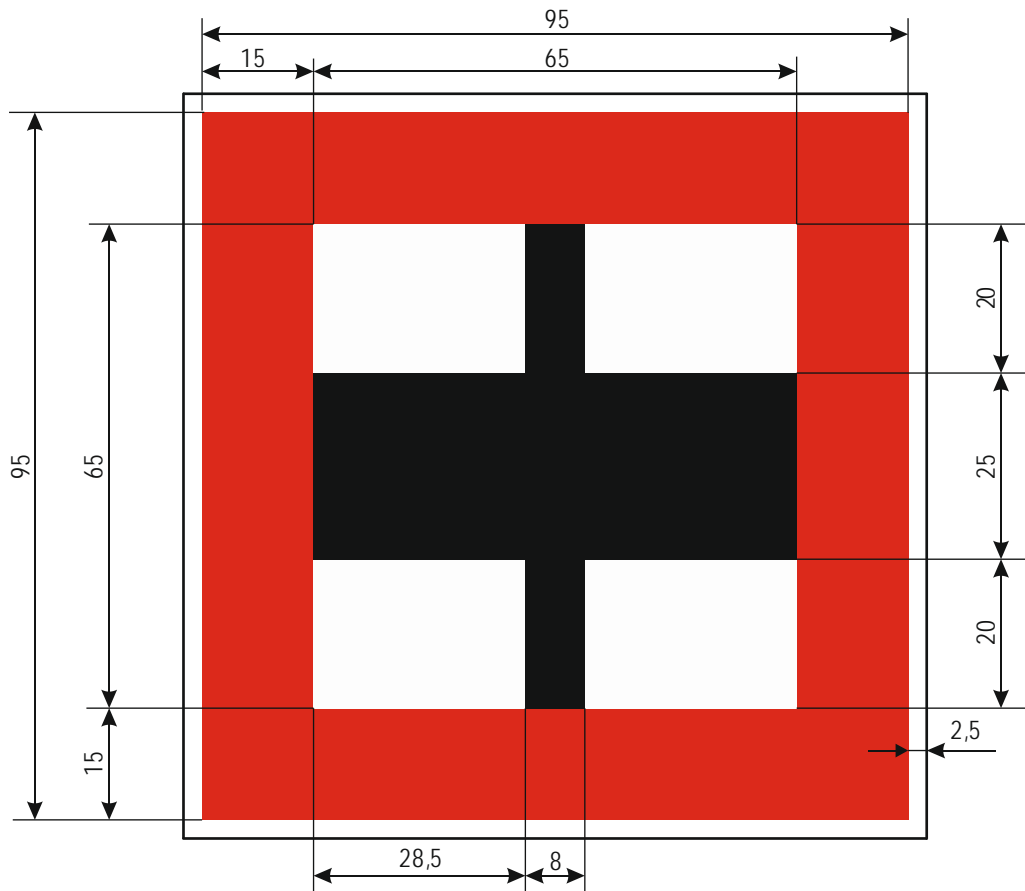

B.11a Obligation to enter into a radiotelephone link

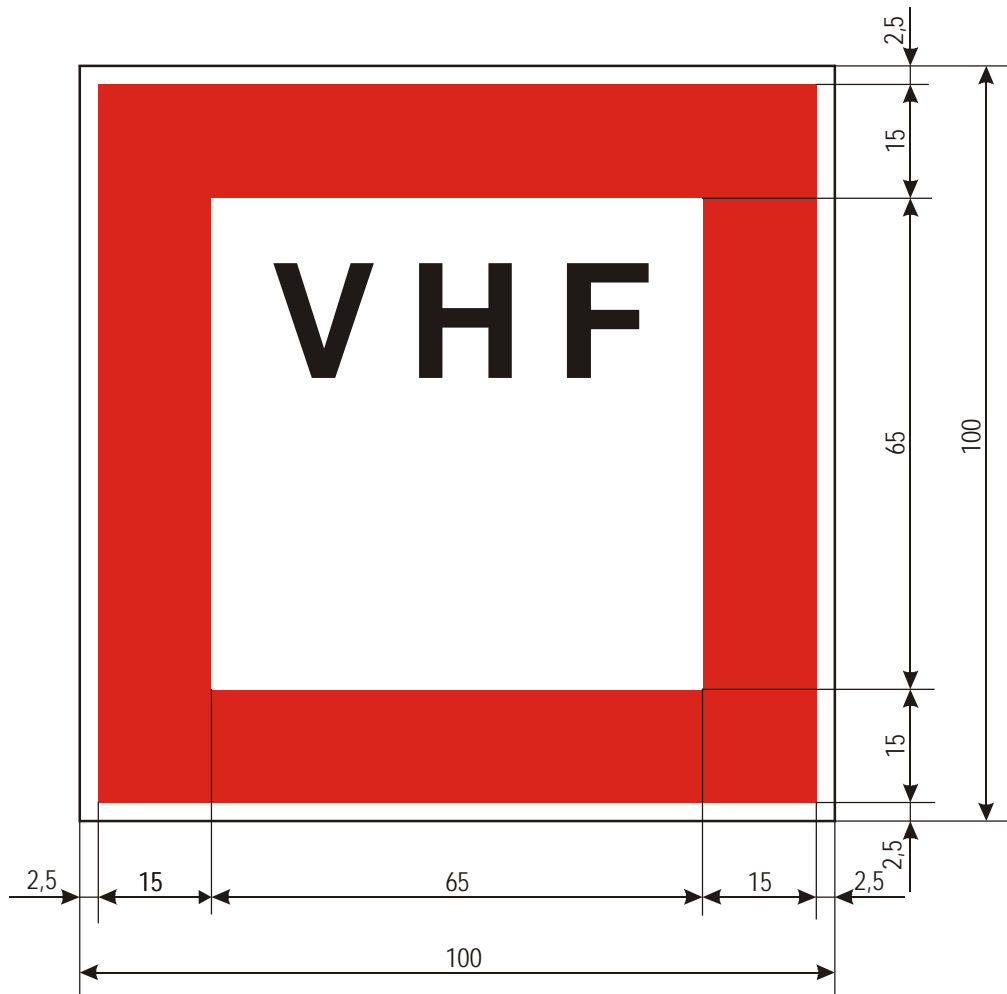

B.11b Obligation to enter into a radiotelephone link on the channel as indicated on the board

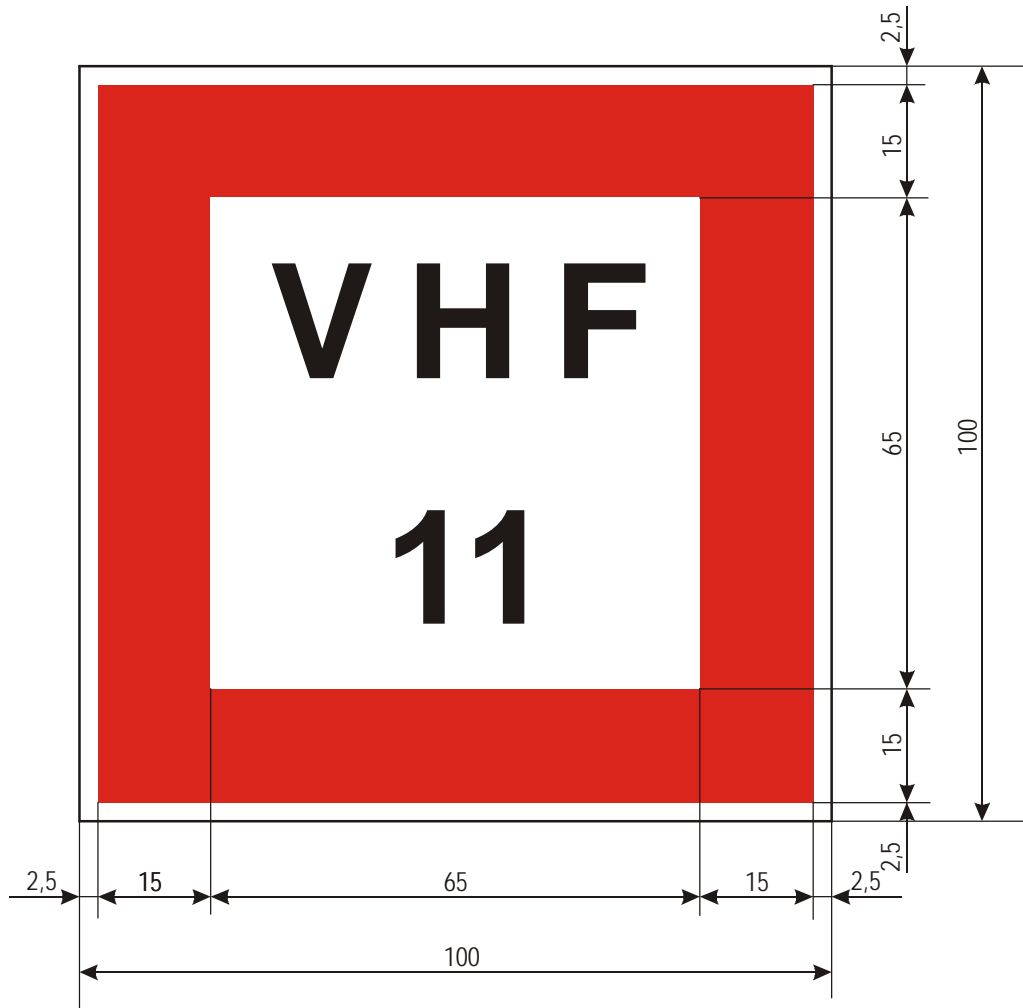

C. *Restrictive signs*

C.1 Depth of water limited

(a) C.1a

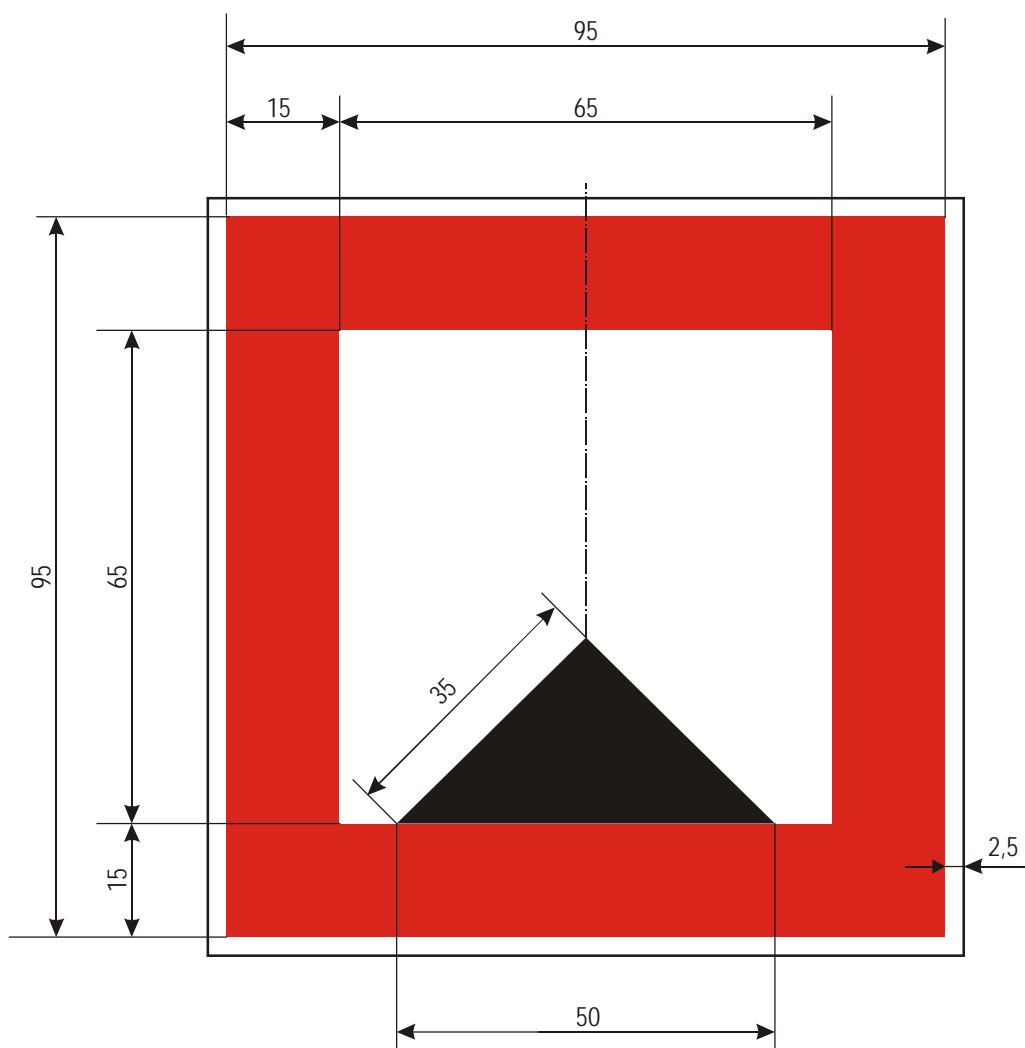

(b) C.1b

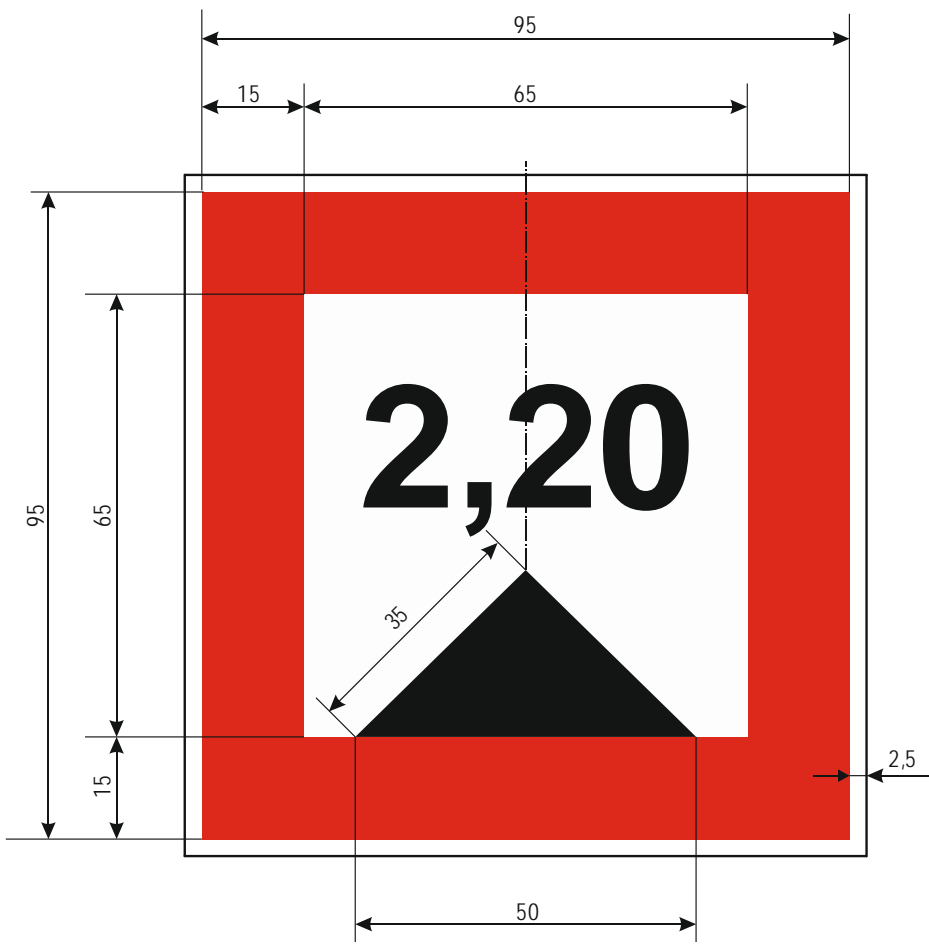

C.2 Headroom limited

(a) C.2a

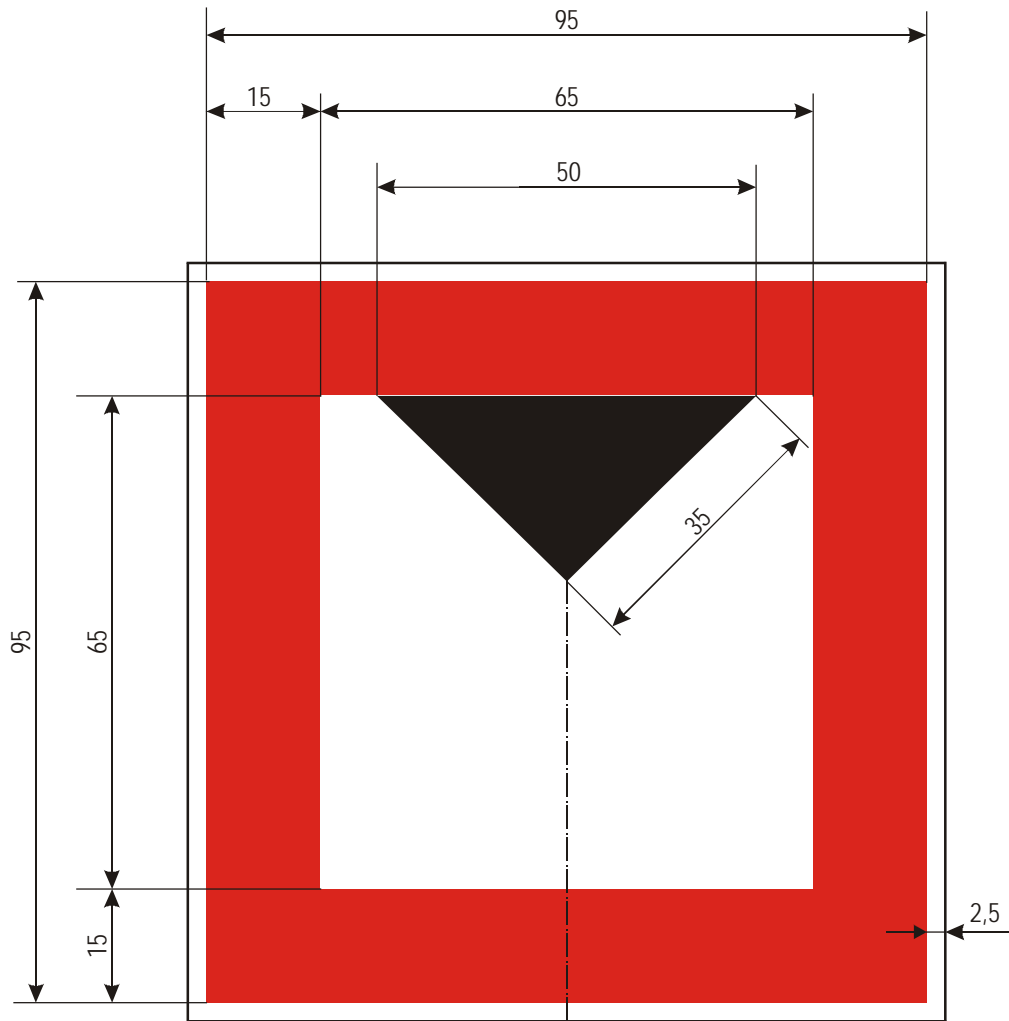

(b) C.2b

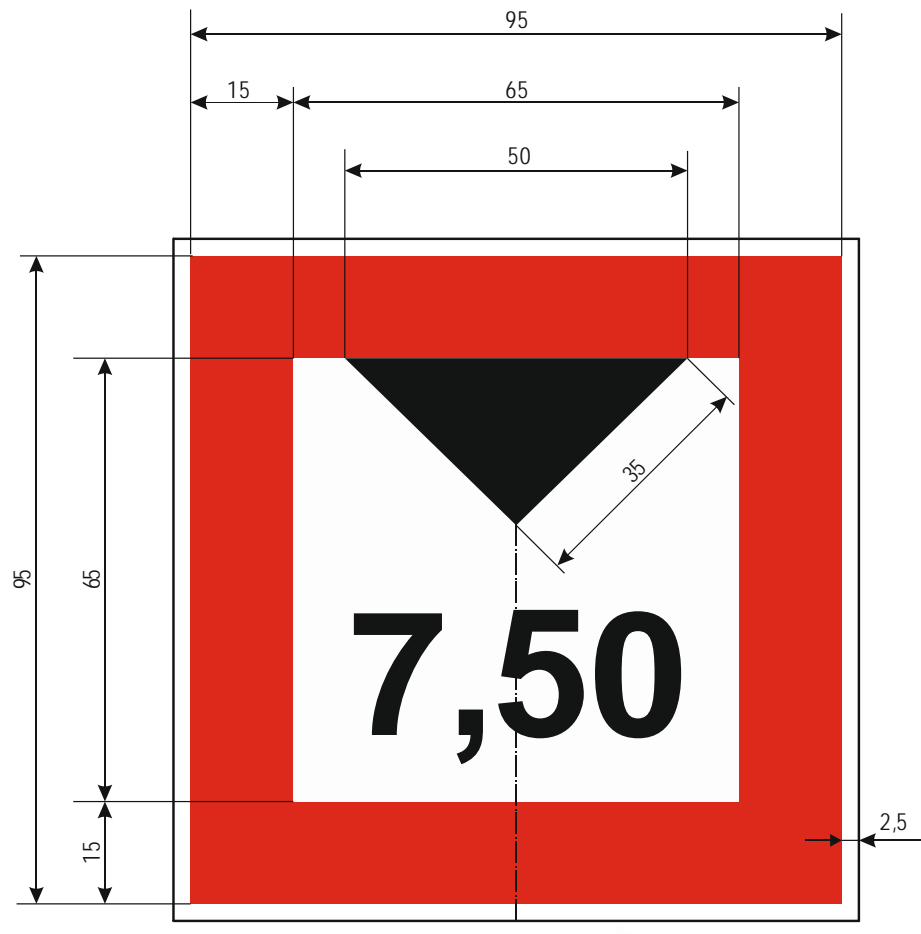

C.3 Width of passage or channel limited

(a) C.3a

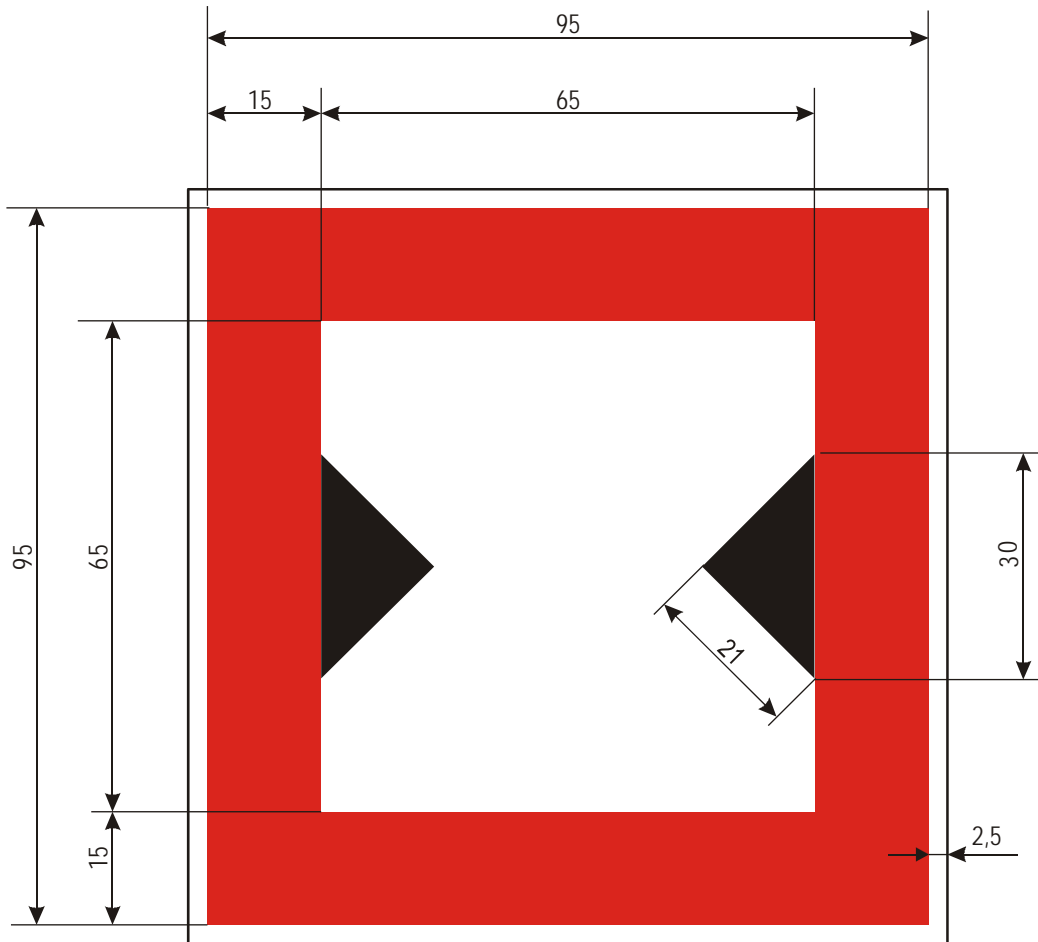

(b) C.3b

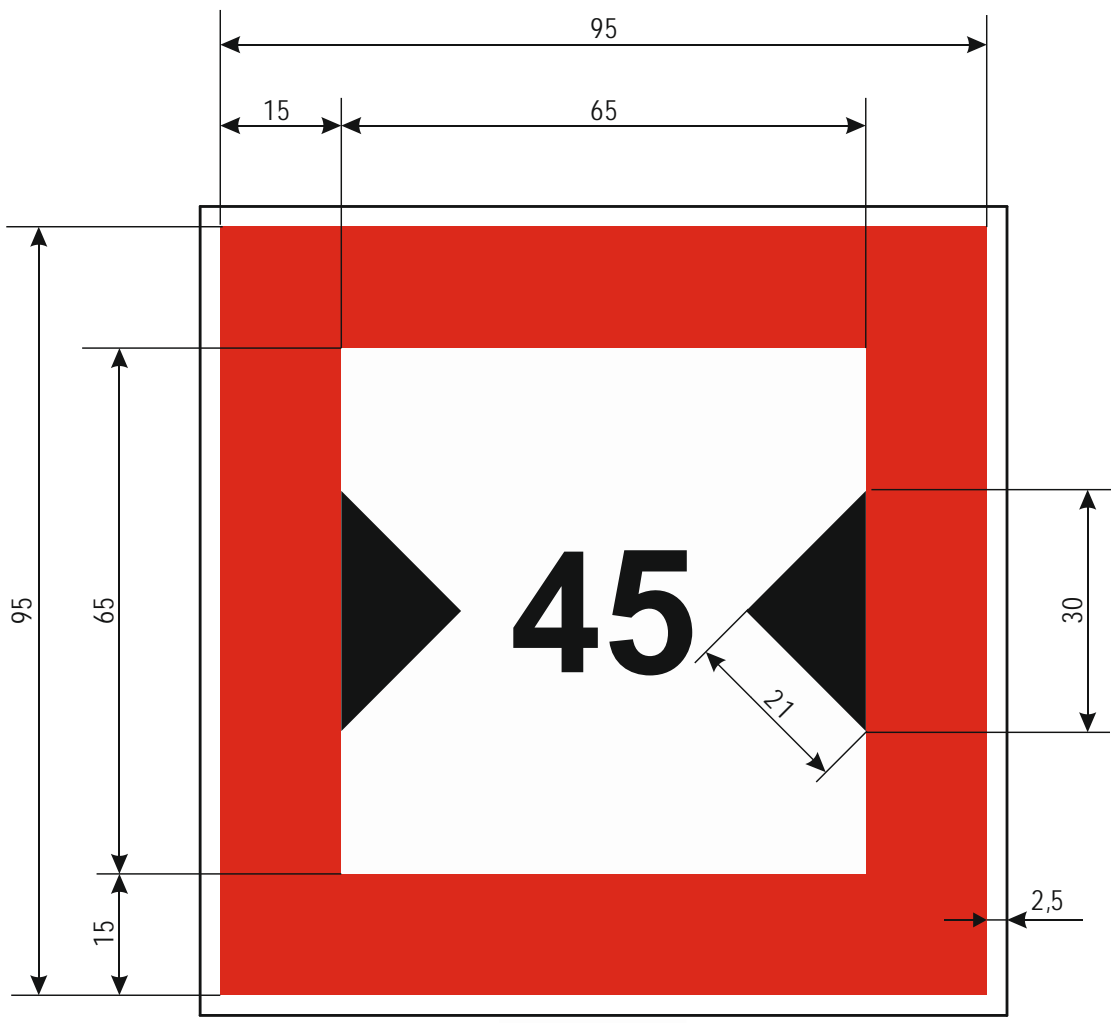

C.4 There are restrictions on navigation: see the information plate below the sign

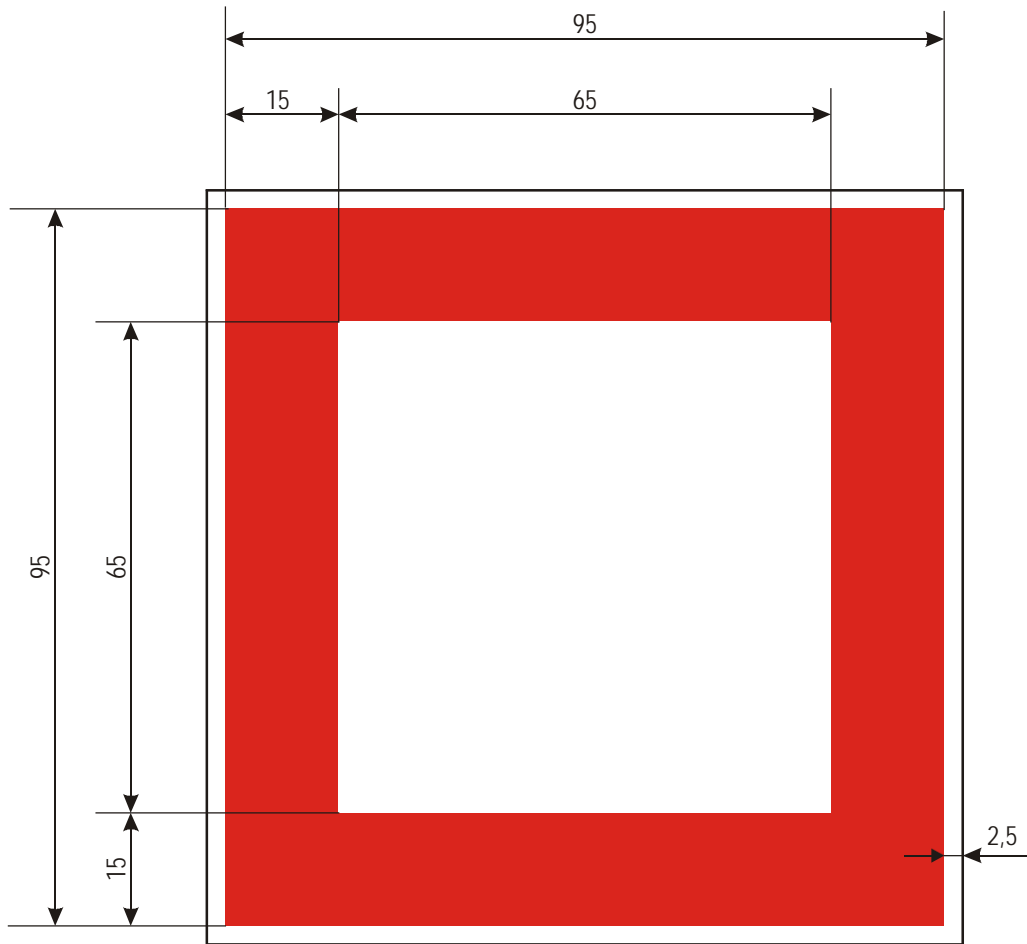

C.5 The channel lies at a distance from the right (left) bank (the fig. shown on the sign indicates the distance in metres, measured from the sign, to which vessels should keep)

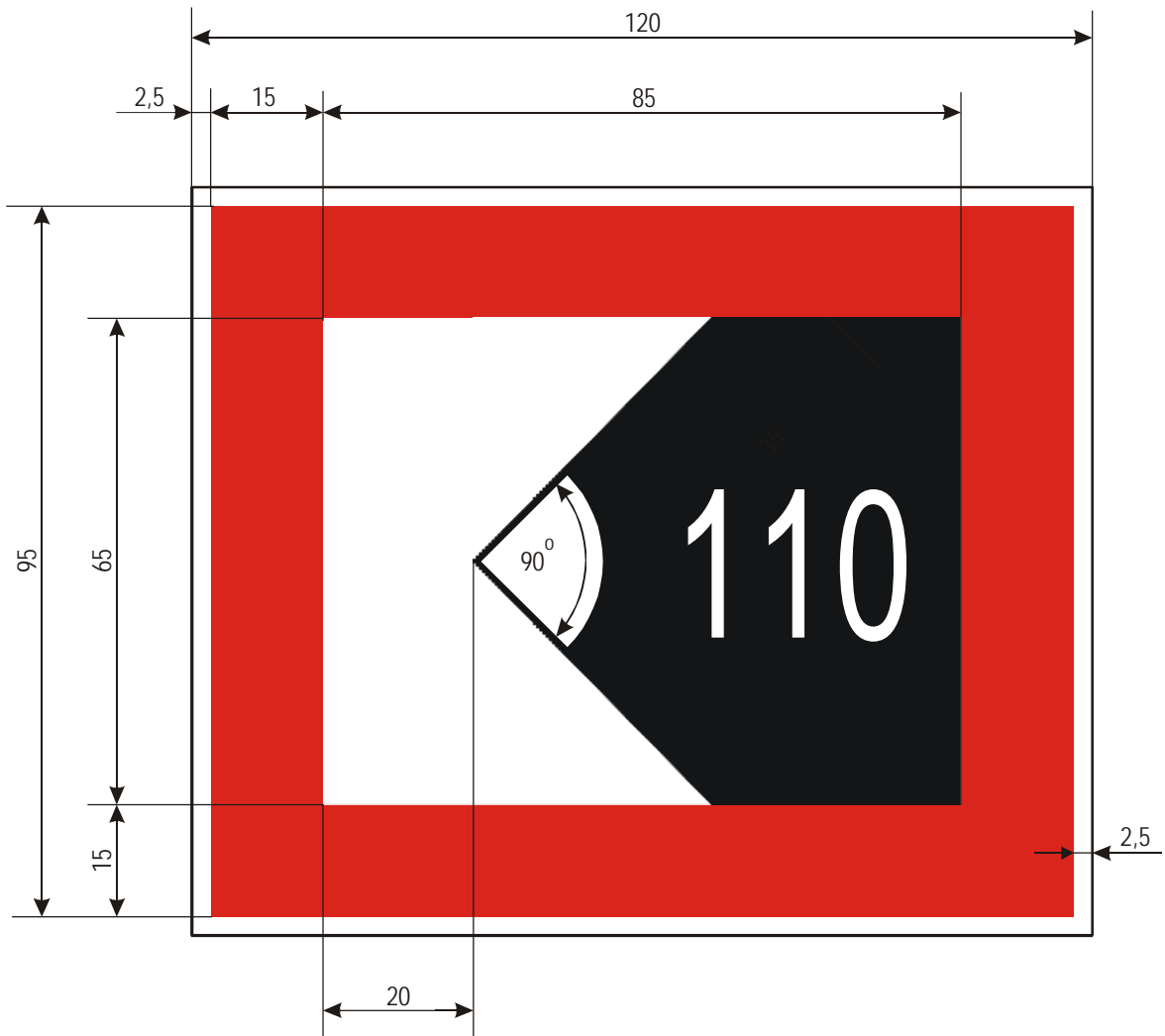

- D. *Recommendatory signs*
- D.1 Recommended opening
 - (a) D.1a In both directions

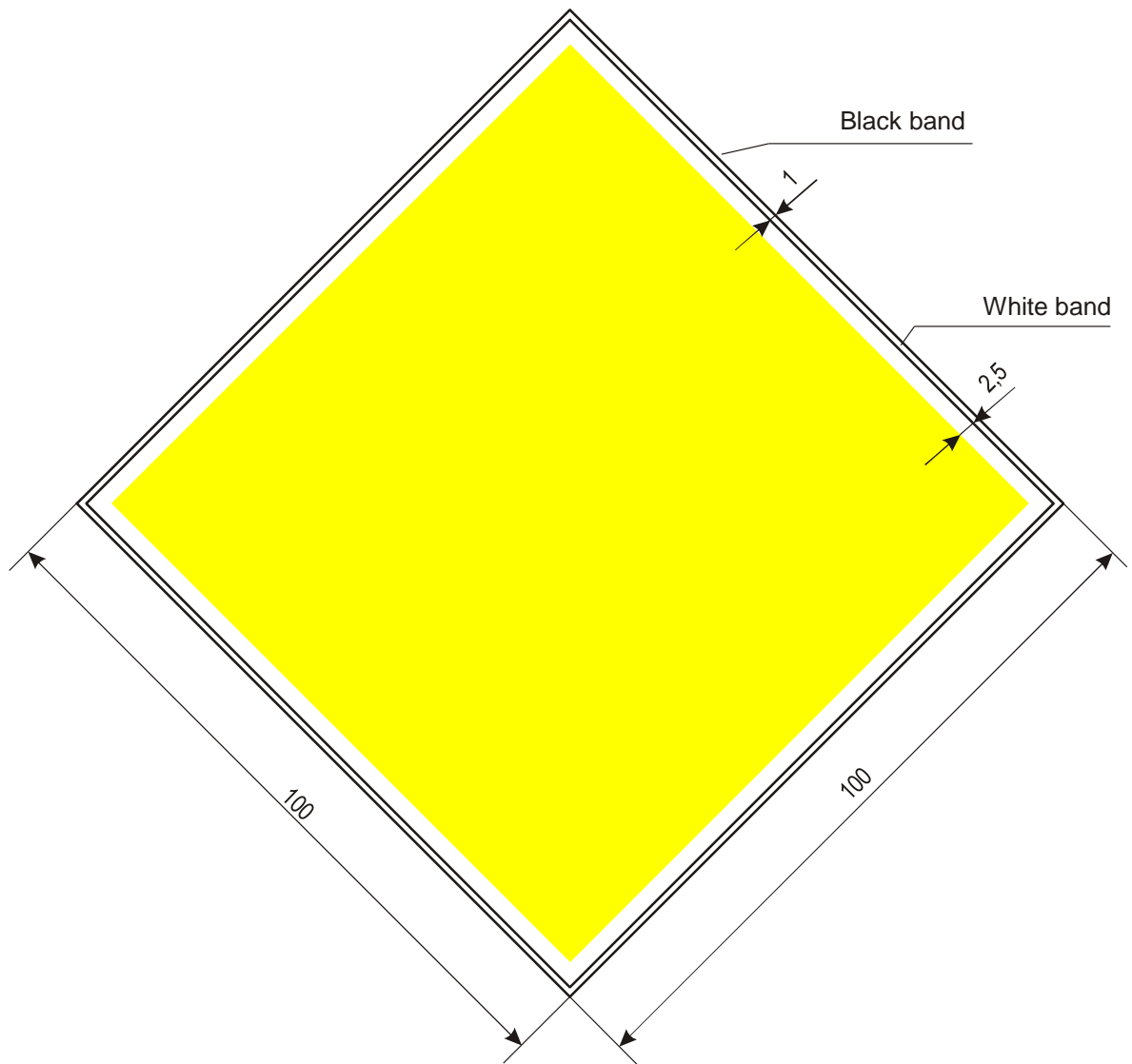

(b) D.1c Only in the direction indicated (passage in the opposite direction prohibited)

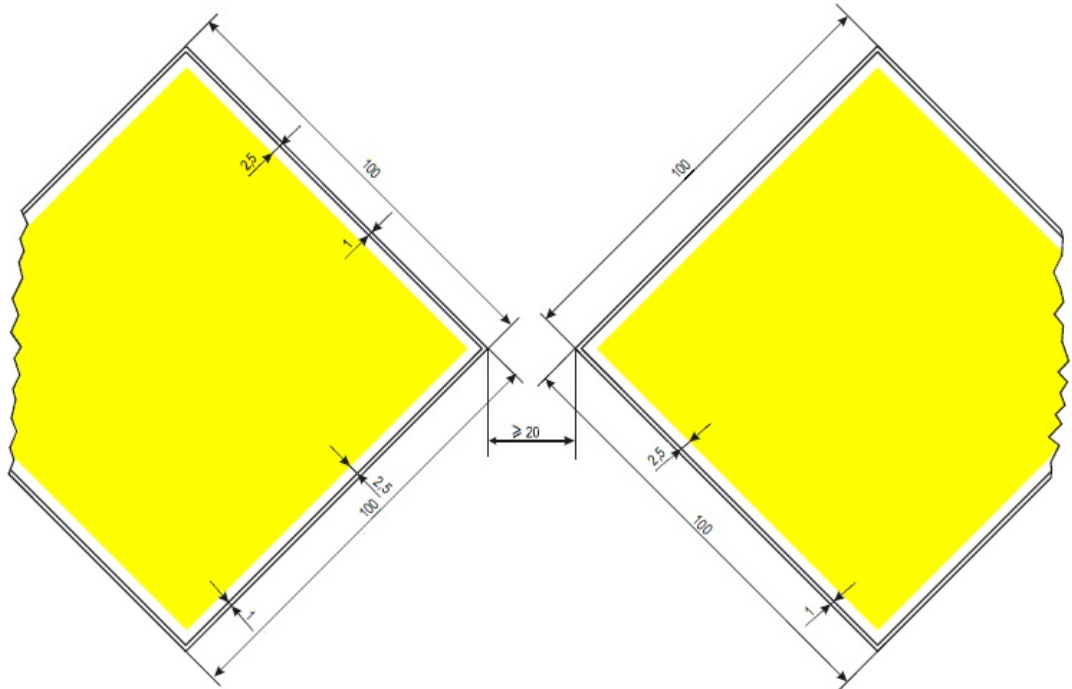

(c) D.1d

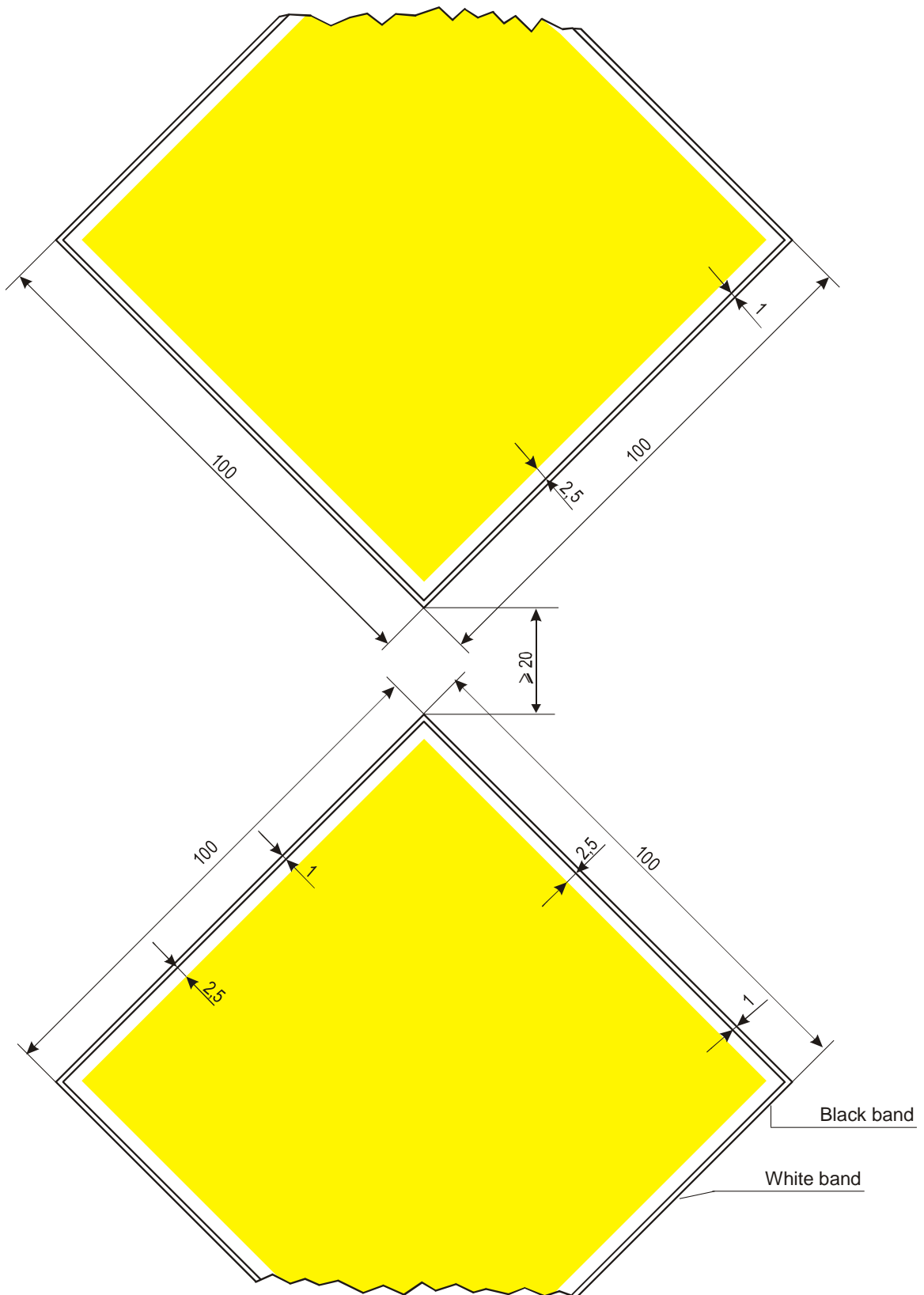

D.2 You are recommended to keep within the area indicated (in openings of bridges or weirs)

D.2a

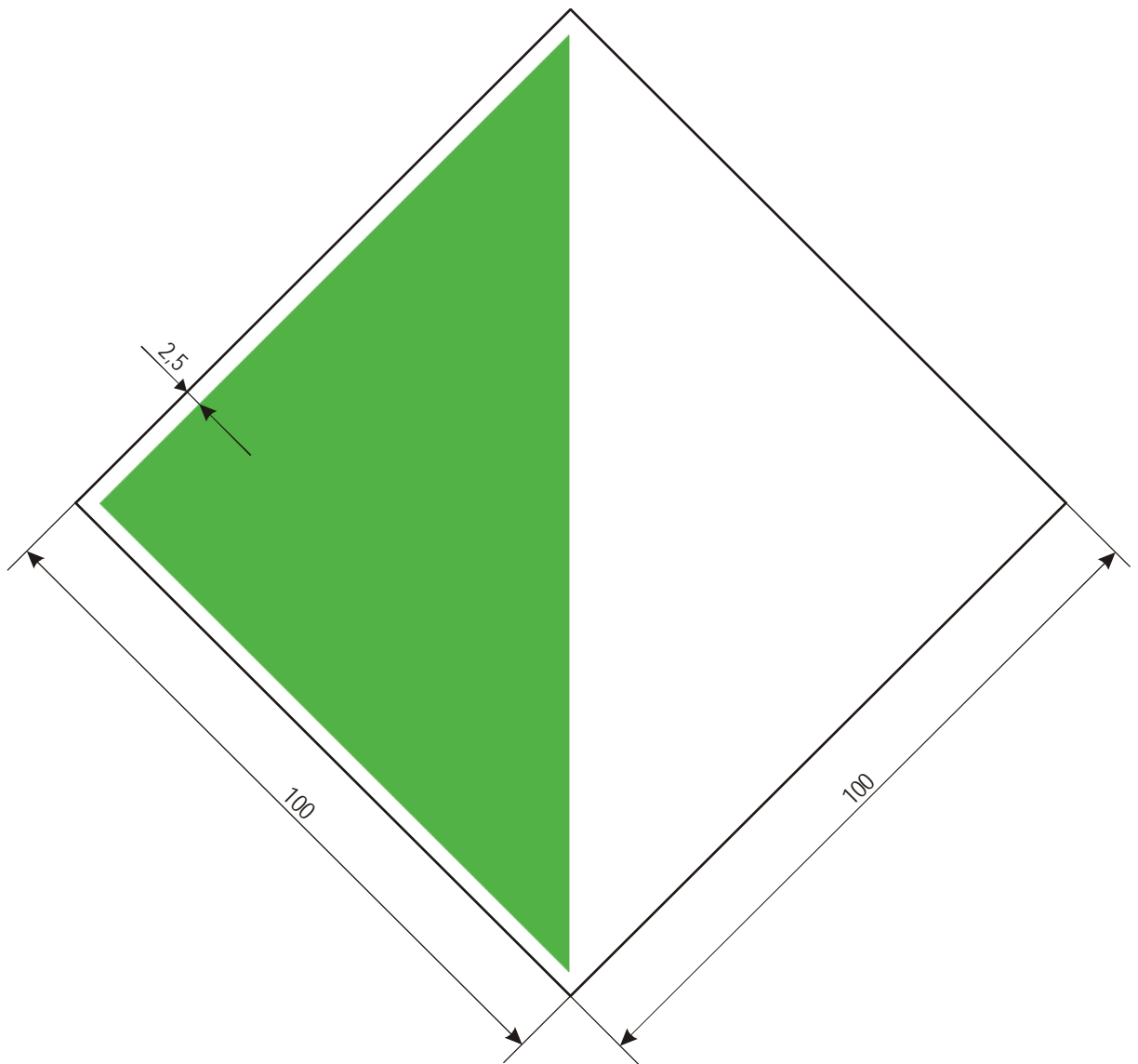

D.3 You are recommended to proceed:

D.3a In the direction shown by the arrow

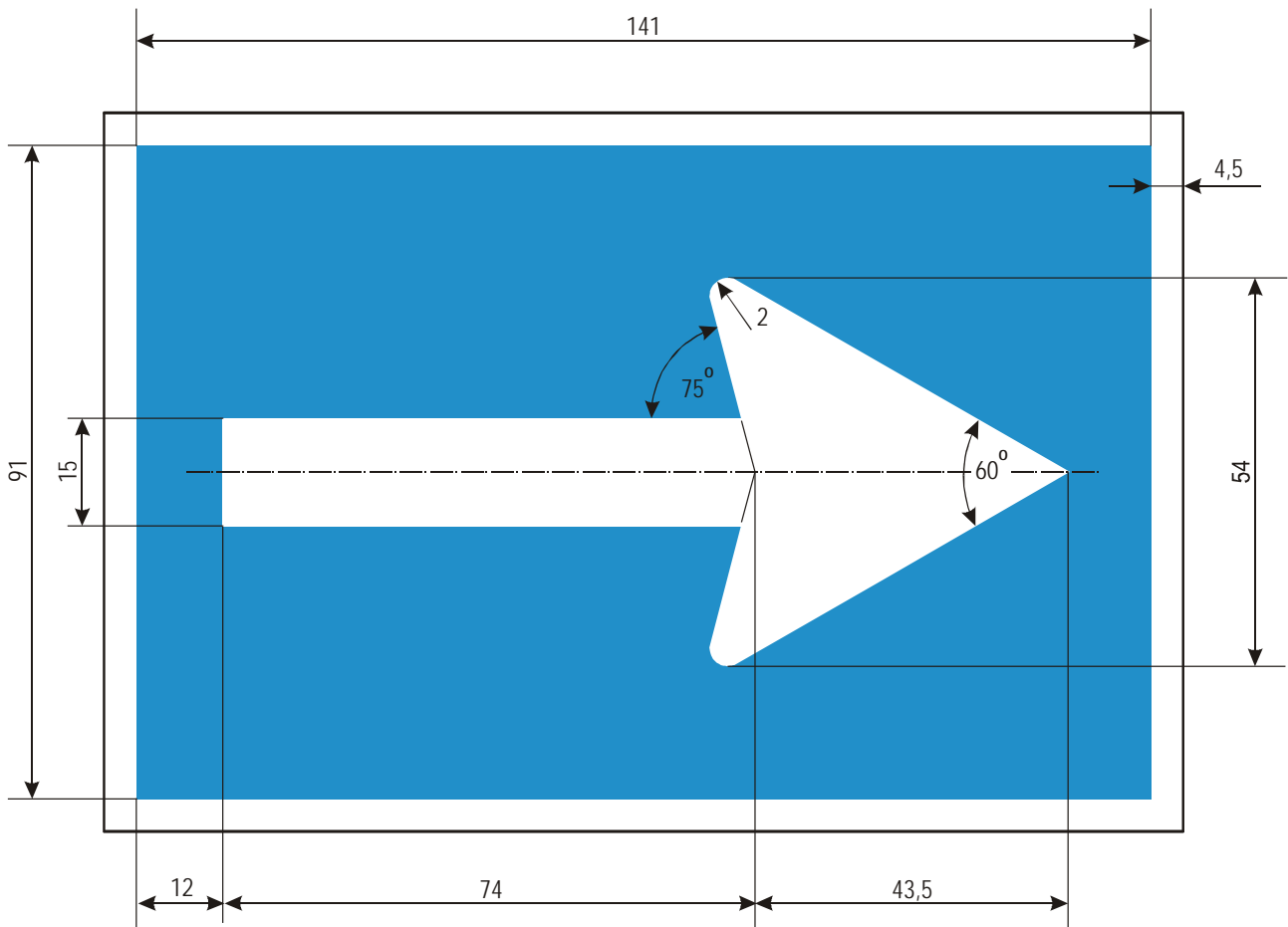

E. *Informative signs*

E.1a Entry permitted

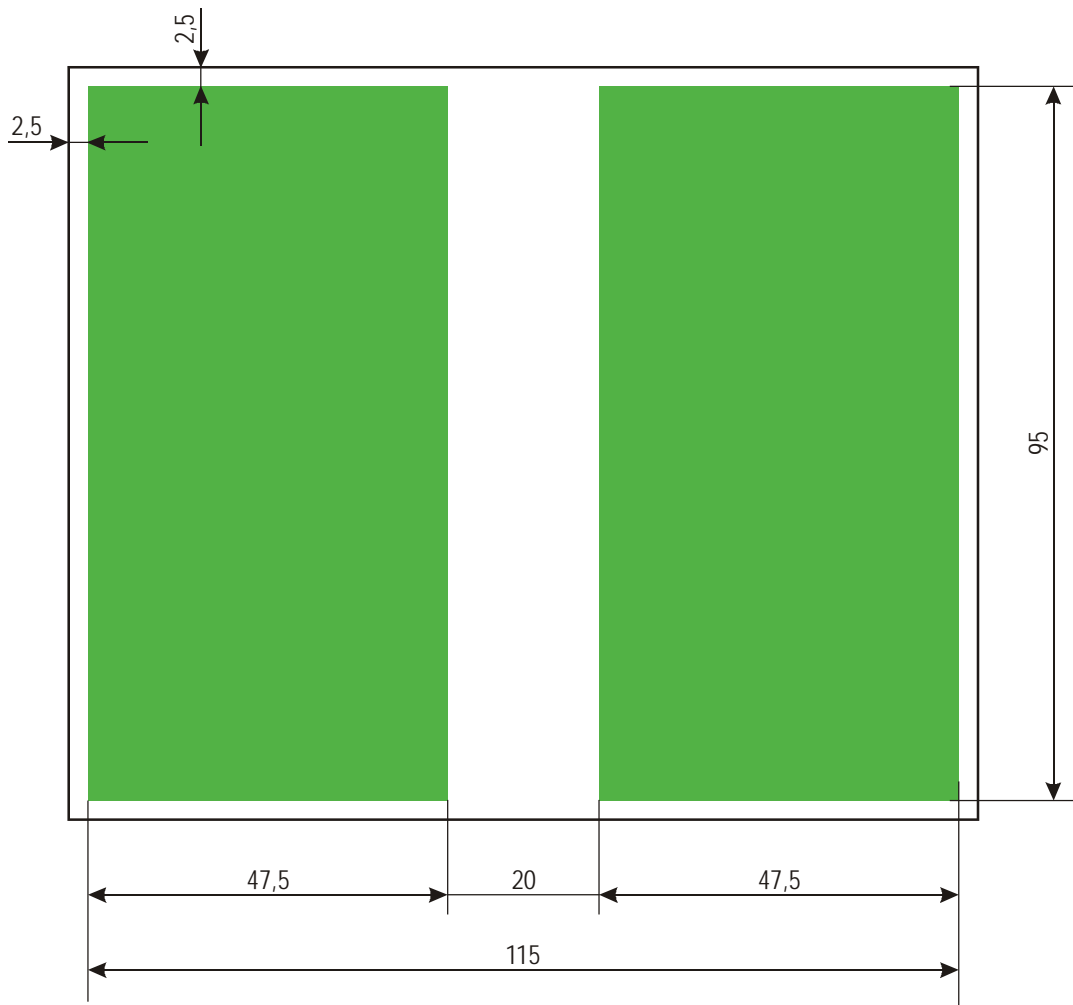

E.2 Overhead cable crossing

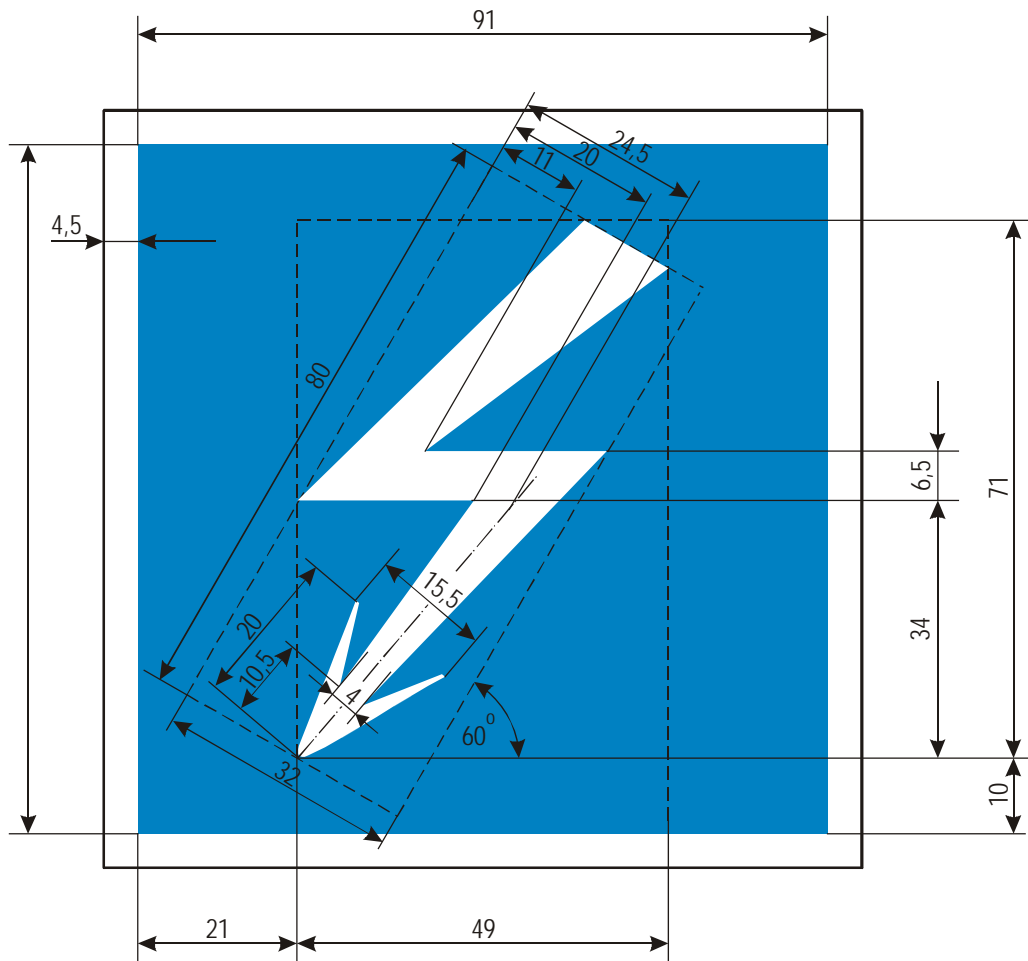

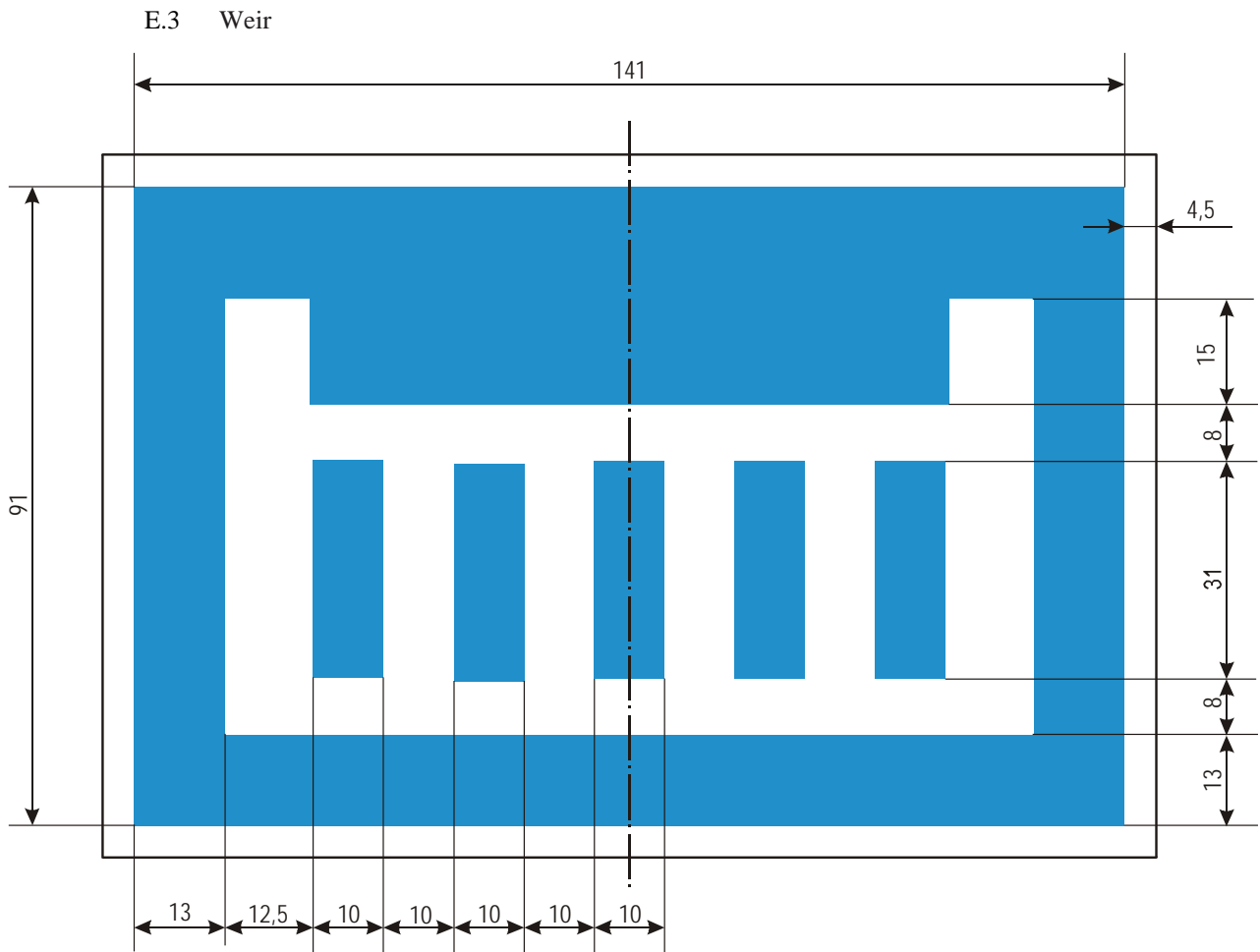

E.4a Ferry-boat not moving independently

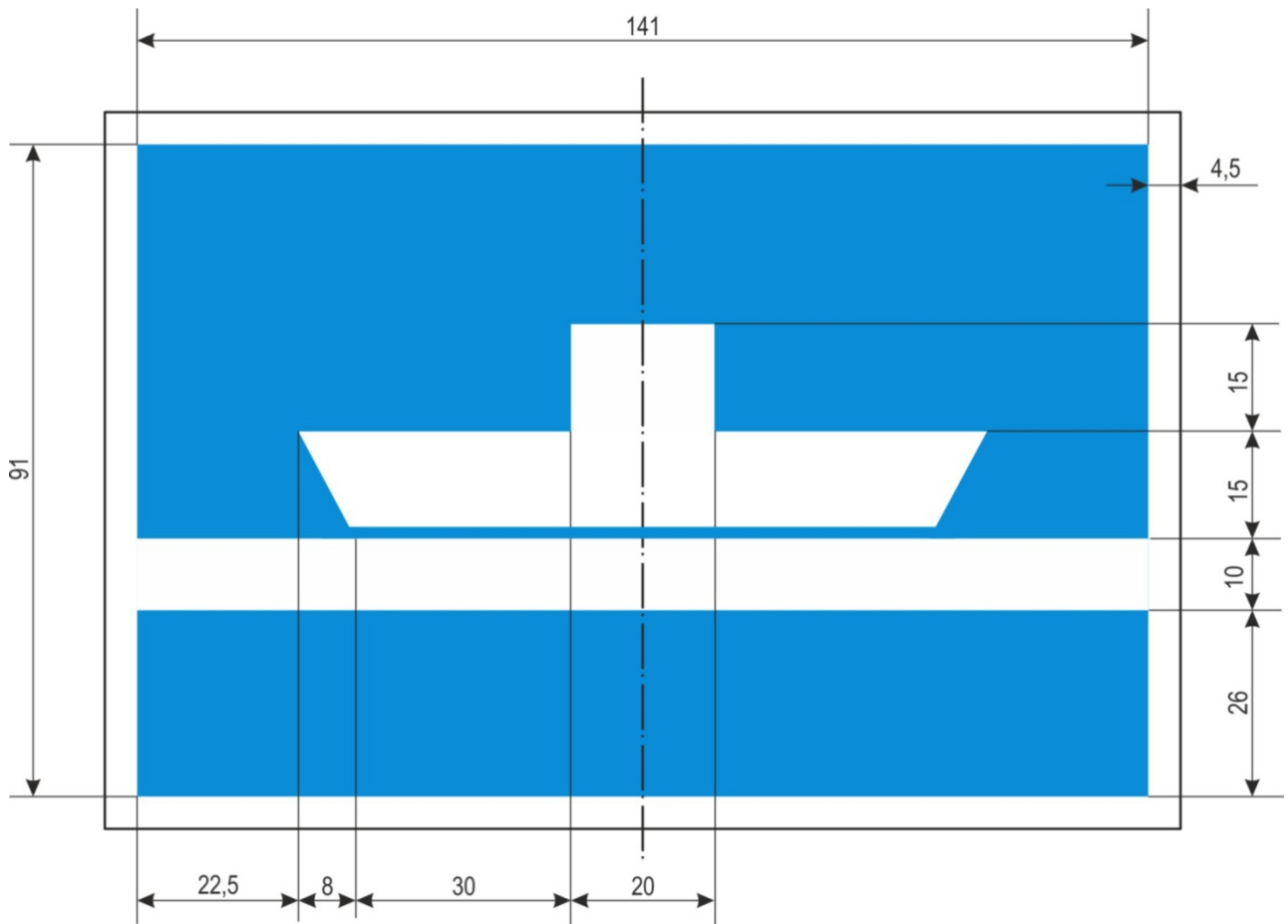

E.4b Ferry-boat moving independently

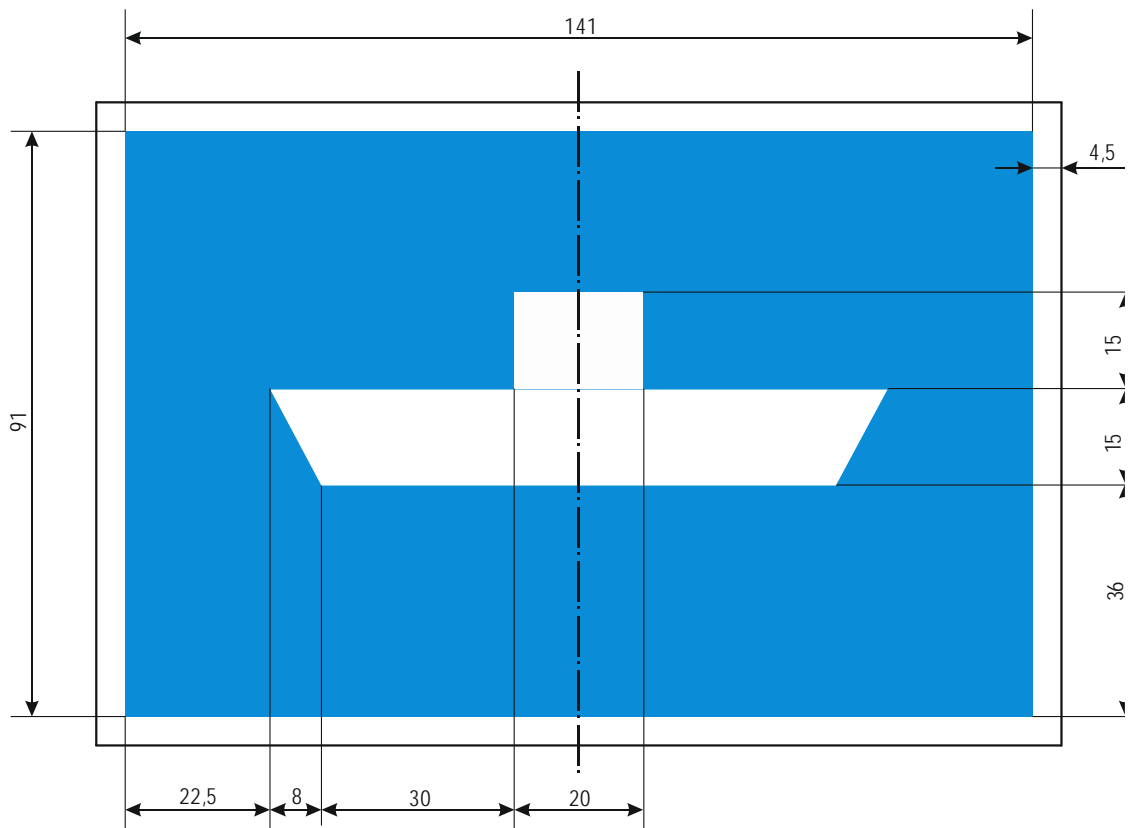

E.5 Berthing (i.e. anchoring or making fast to the bank) permitted on the side of the waterway on which the sign is placed

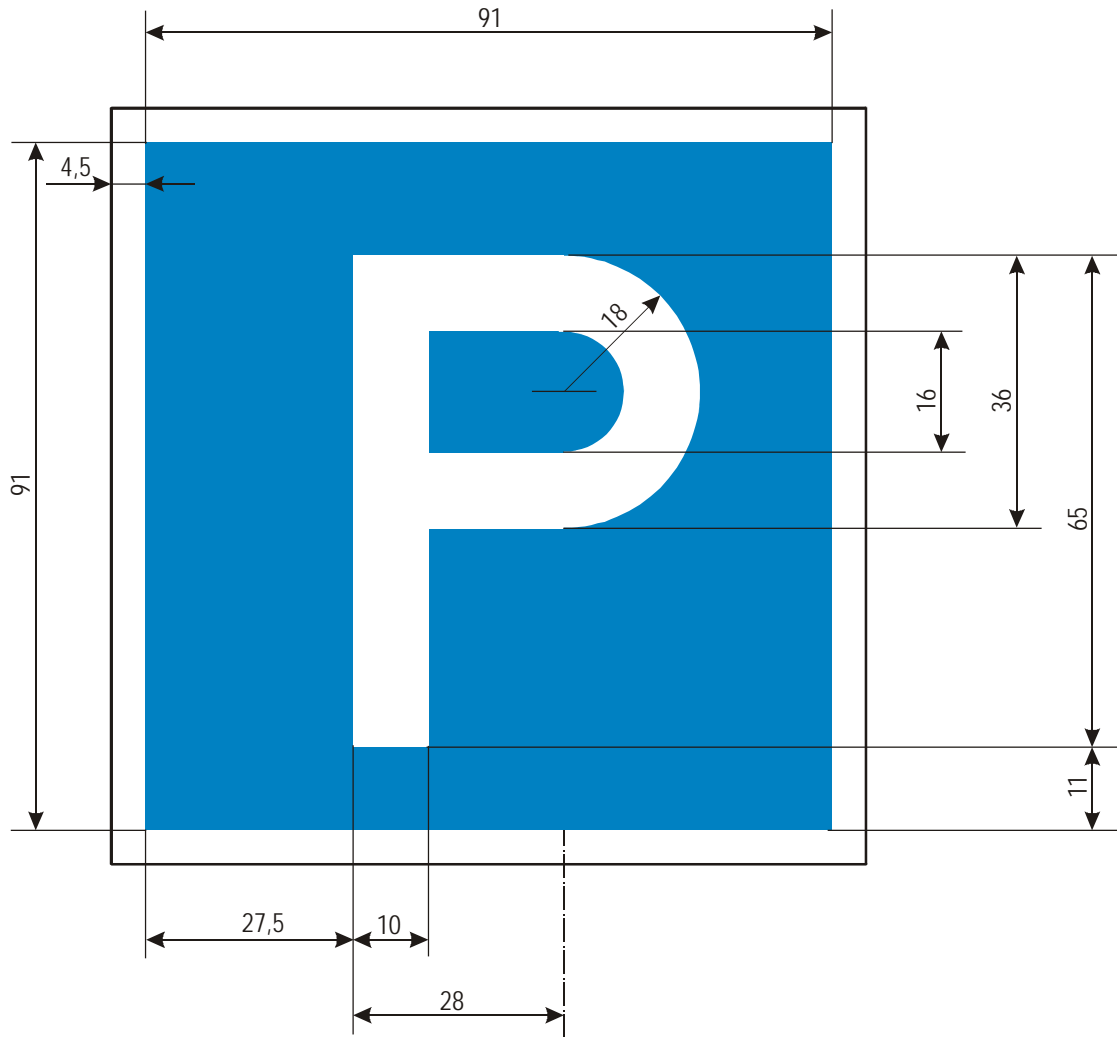

E.5.1 Berthing permitted on the stretch of water of the breadth measured from, and shown on the board in metres

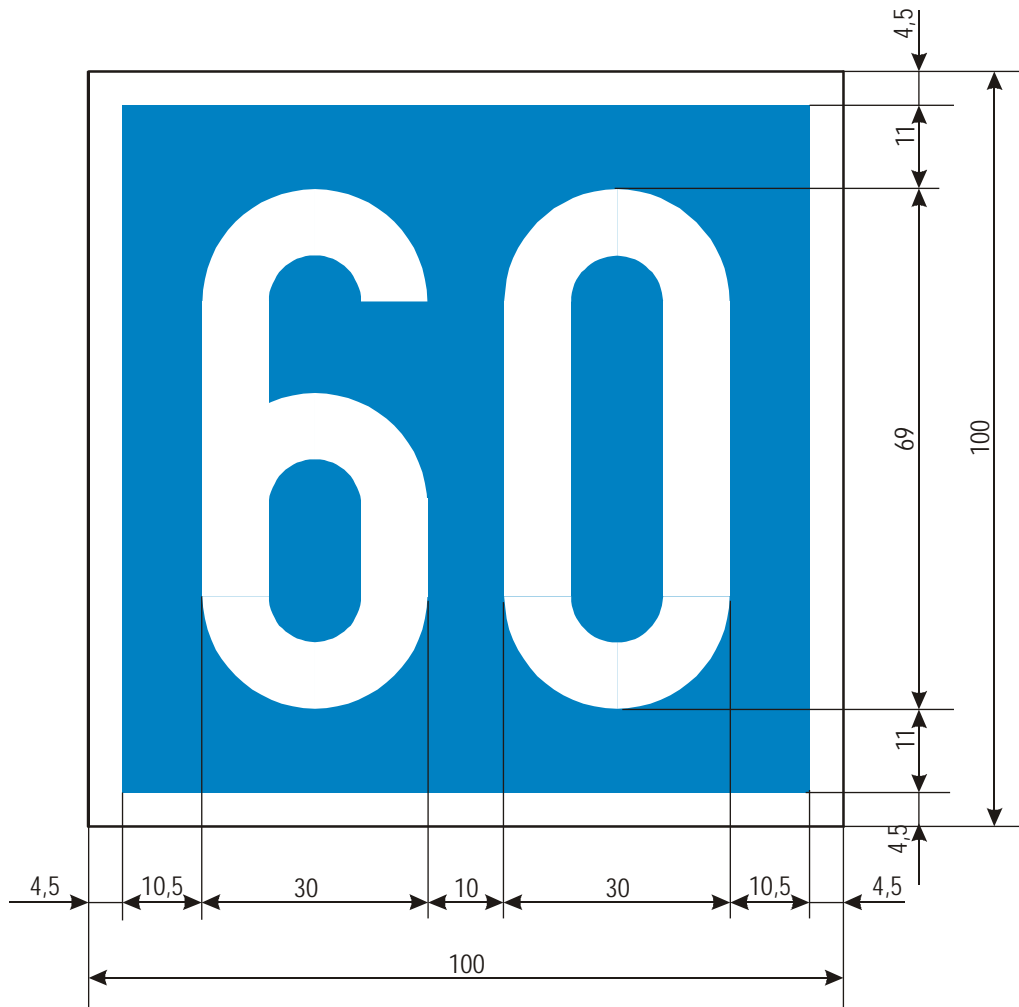

E.5.2 Berthing permitted on the stretch of water bounded by the two distances measured from, and shown on the board in metres

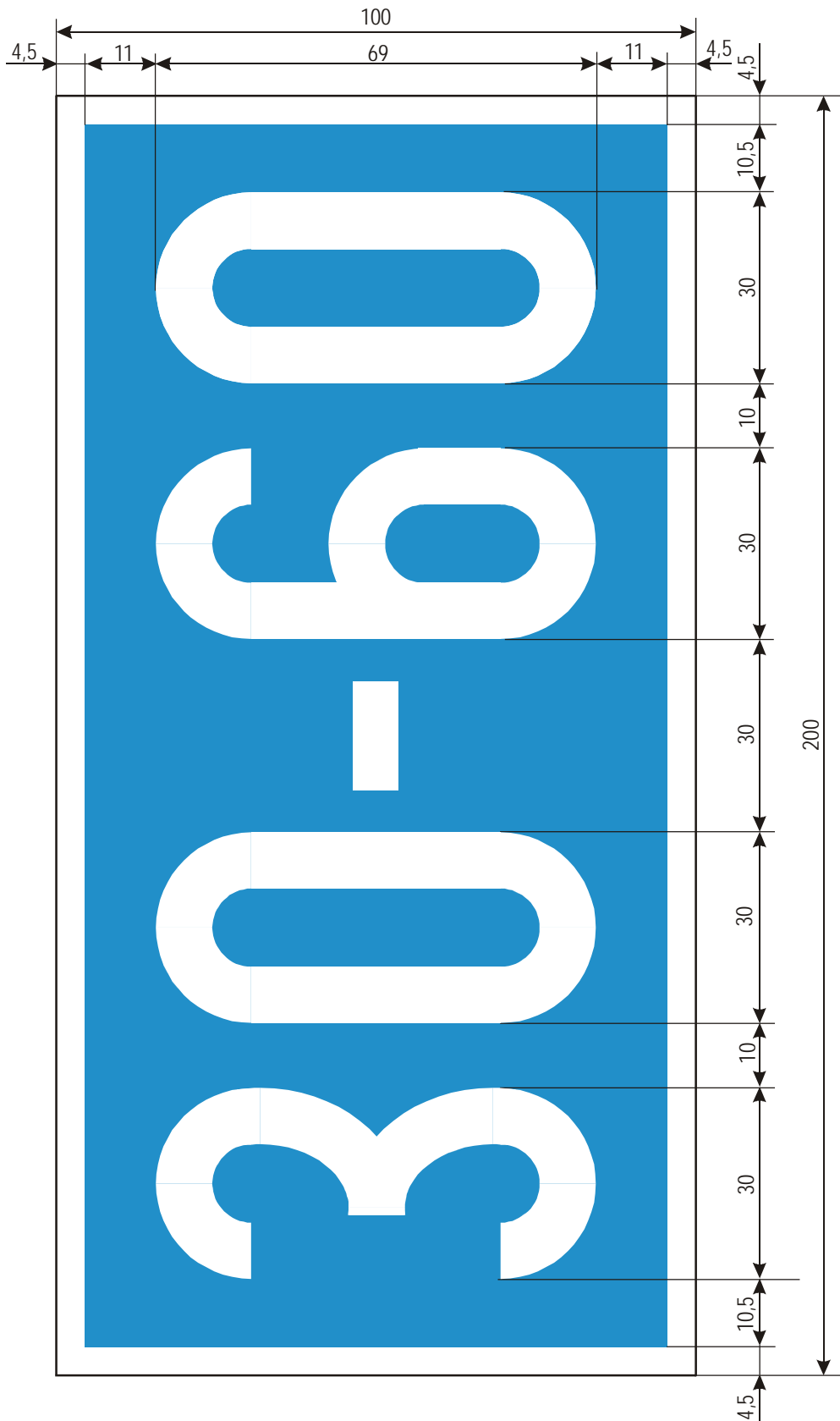

E.5.3 Maximum number of vessels permitted to berth abreast on the side of the waterway on which the sign is placed

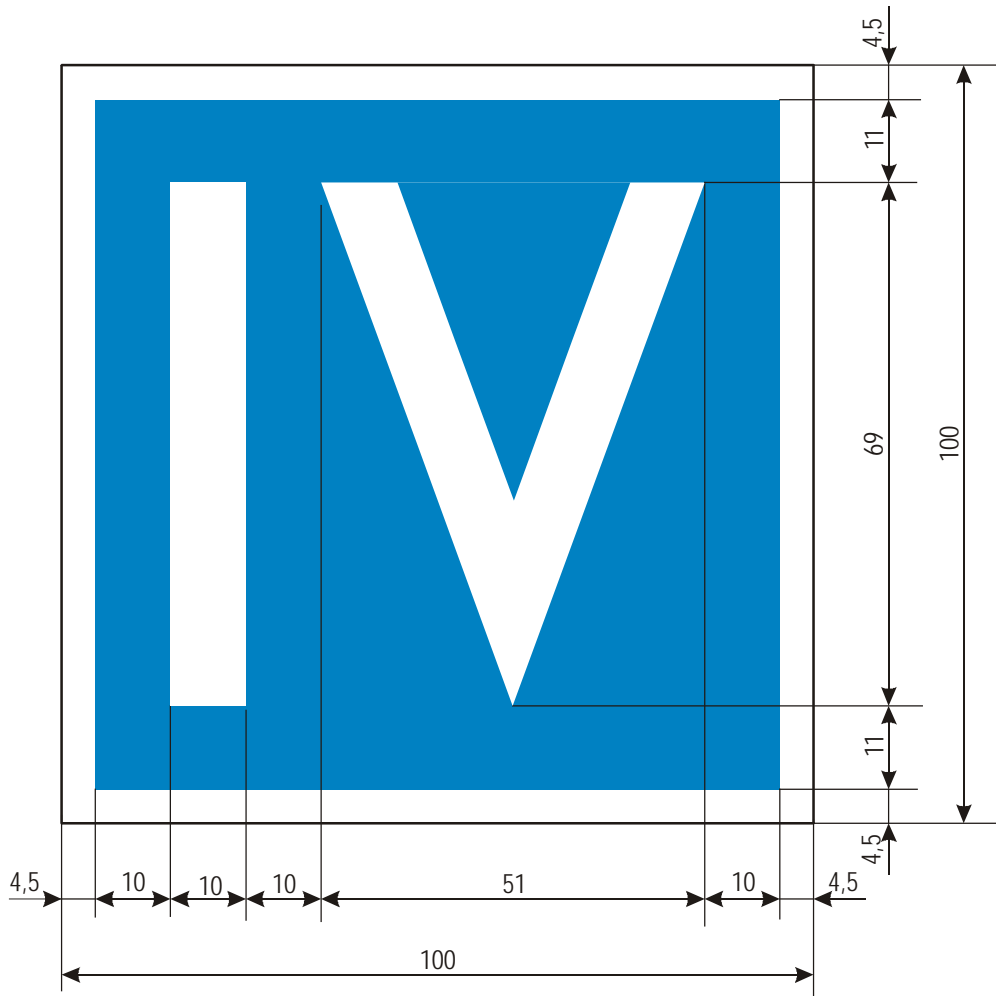

E.5.4 Berthing area reserved for pushing-navigation vessels that are not required to carry the marking prescribed in article 3.14 of CEVNI on the side of the waterway on which the sign is placed

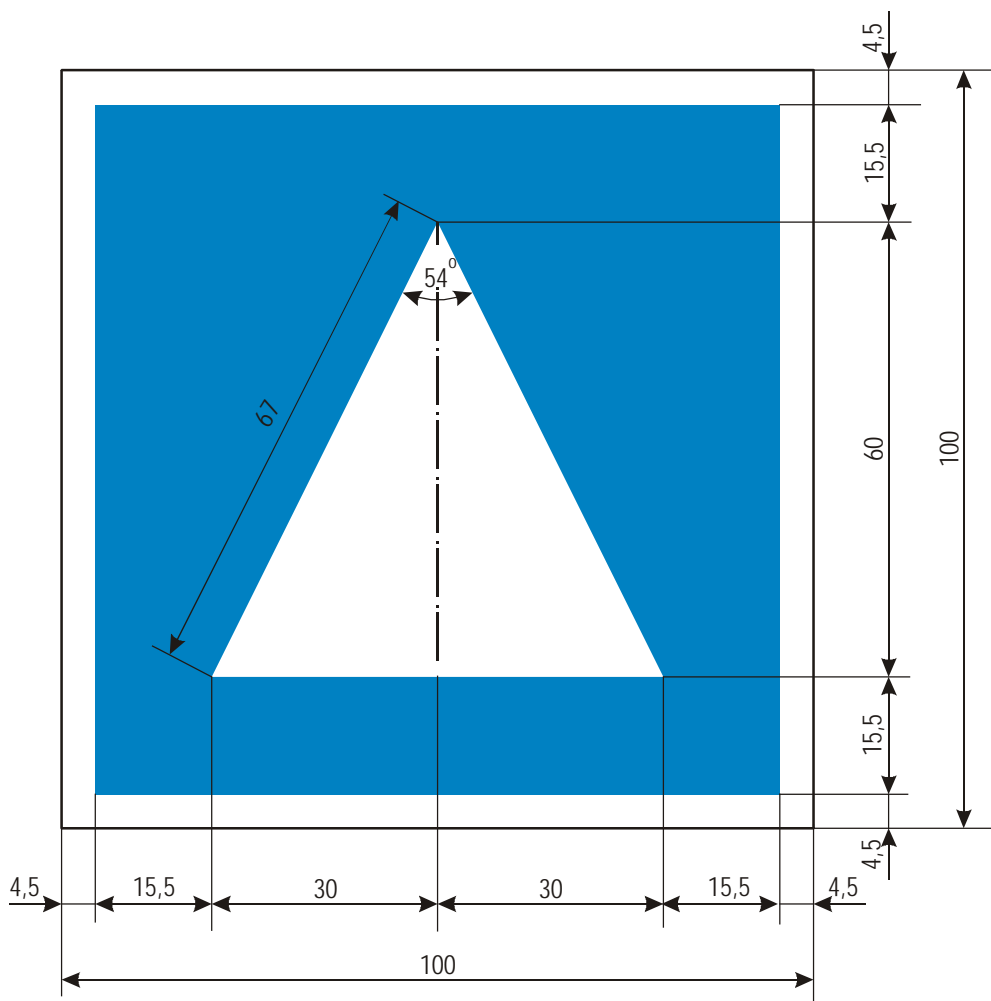

E.5.5 Berthing area reserved for pushing-navigation vessels that are required to carry one blue light or one blue cone under article 3.14, para. 1 of CEVNI on the side of the waterway on which the sign is placed

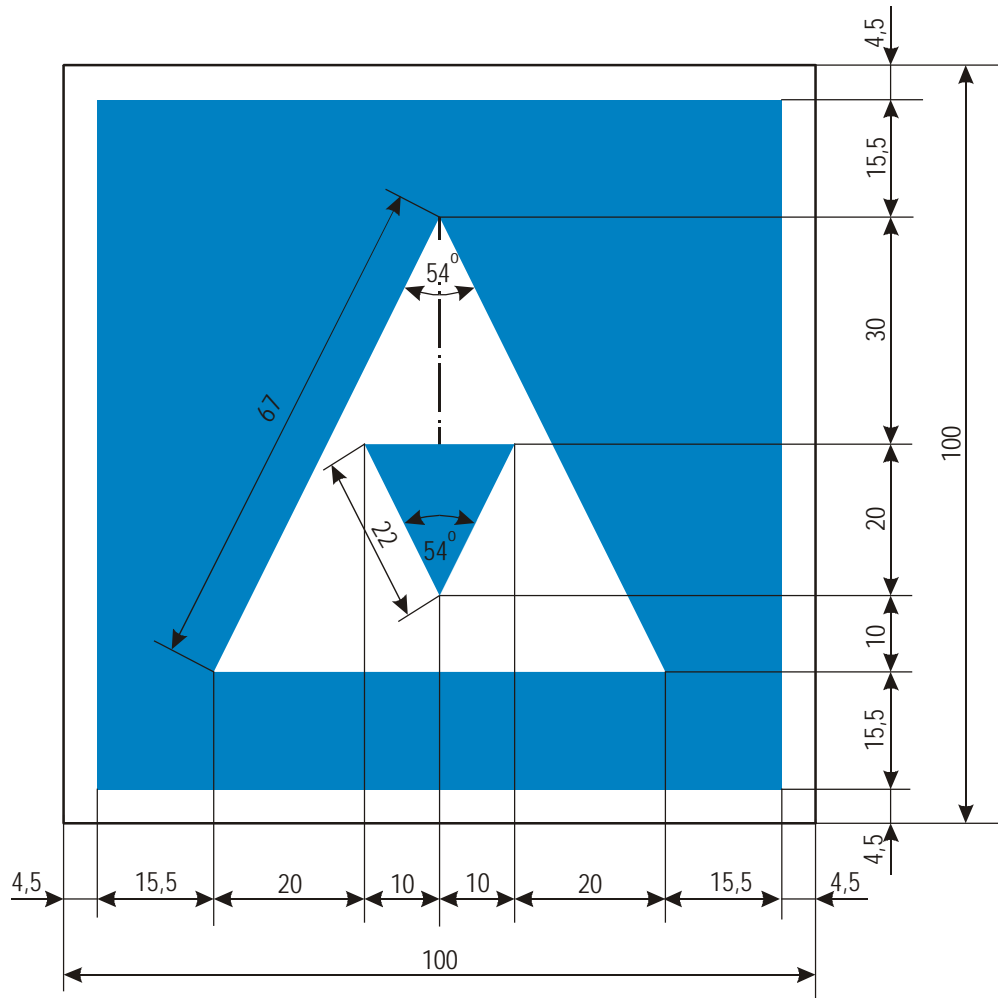

E.5.7 Berthing area reserved for pushing-navigation vessels that are required to carry three blue lights or three blue cones under article 3.14, para. 3 of CEVNI on the side of the waterway on which the sign is placed

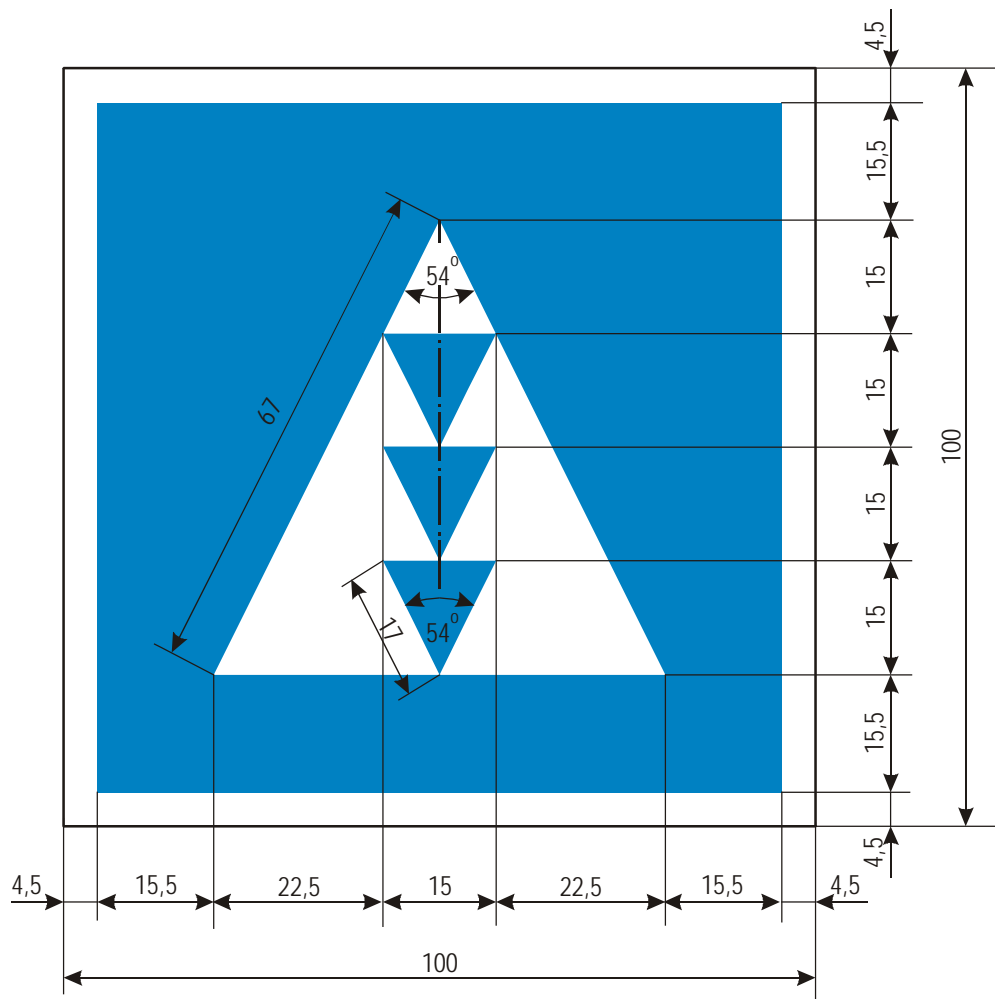

E.5.8 Berthing area reserved for vessels other than pushing-navigation vessels that are not required to carry the marking prescribed in article 3.14 of CEVNI on the side of the waterway on which the sign is placed

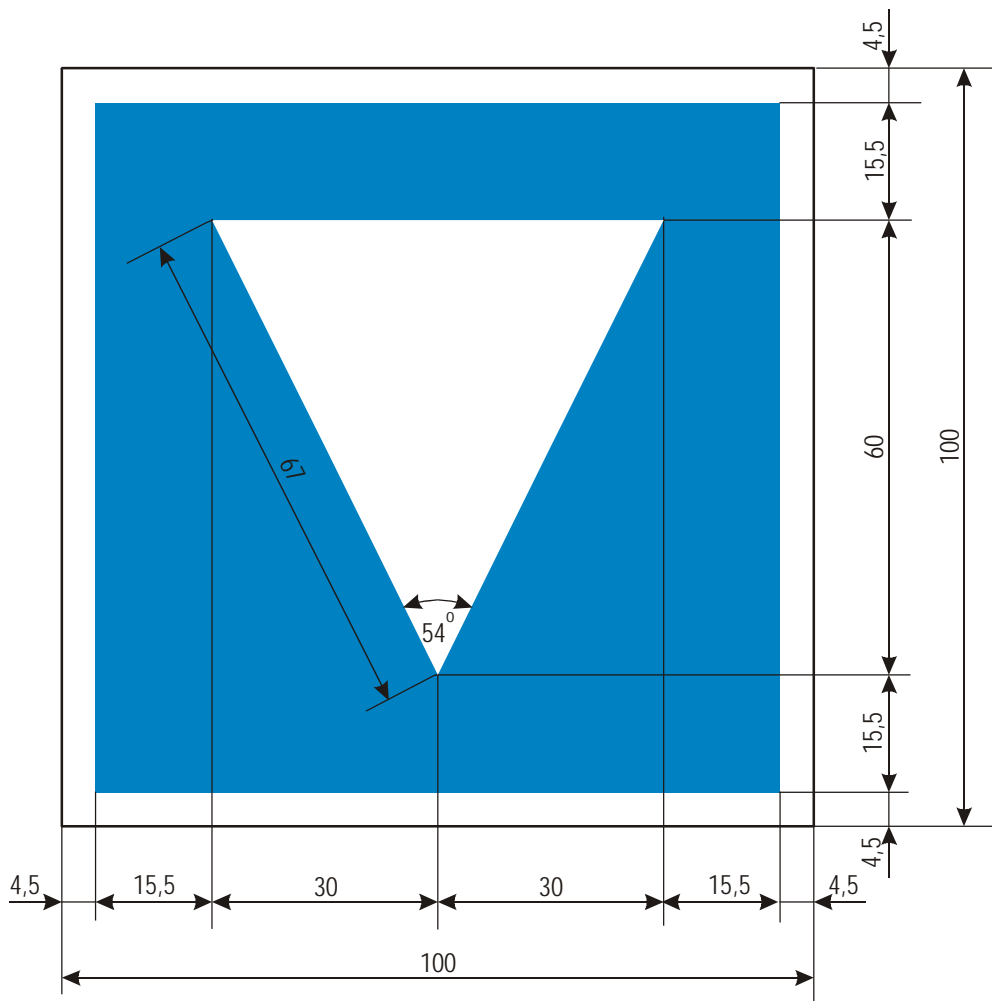

E.5.9 Berthing area reserved for vessels other than pushing-navigation vessels that are required to carry one blue light or one blue cone under article 3.14, para. 1 of CEVNI on the side of the waterway on which the sign is placed

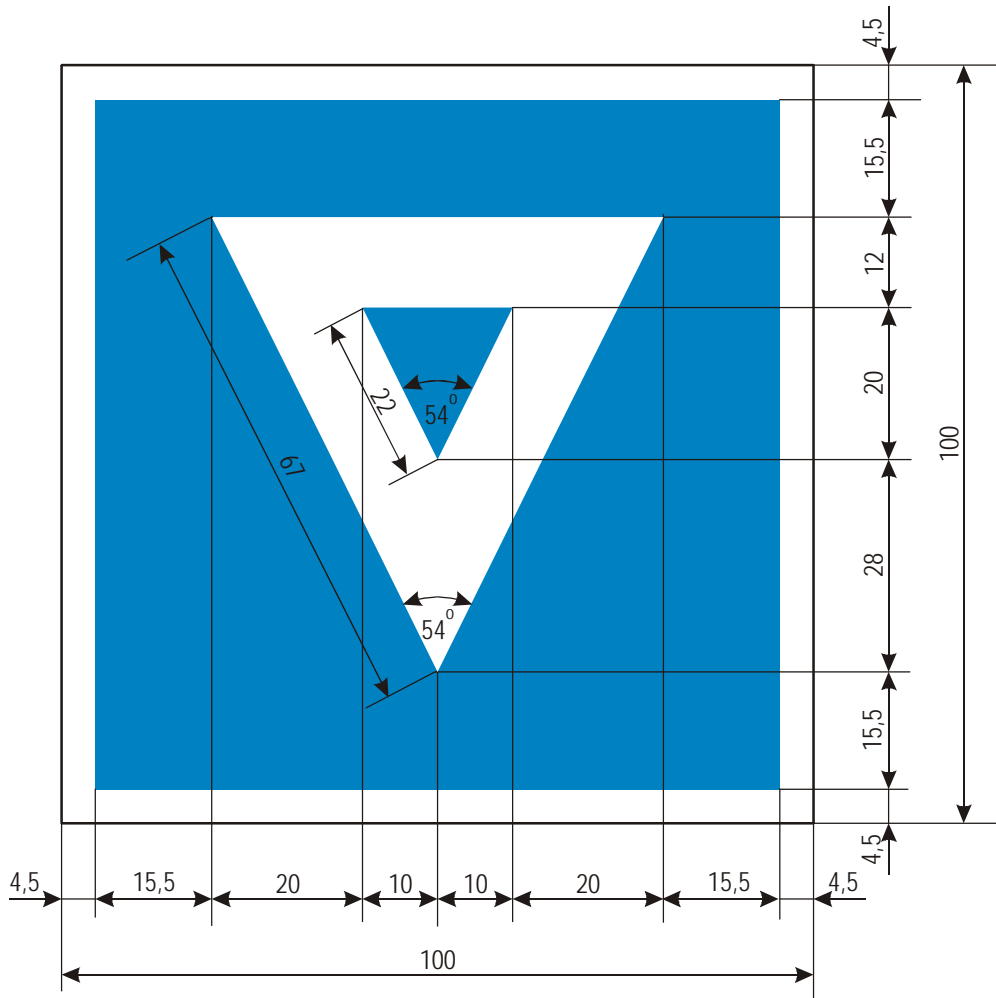

E.5.10 Berthing area reserved for vessels other than pushing-navigation vessels that are required to carry two blue lights or two blue cones under article 3.14, para. 2 of CEVNI on the side of the waterway on which the sign is placed

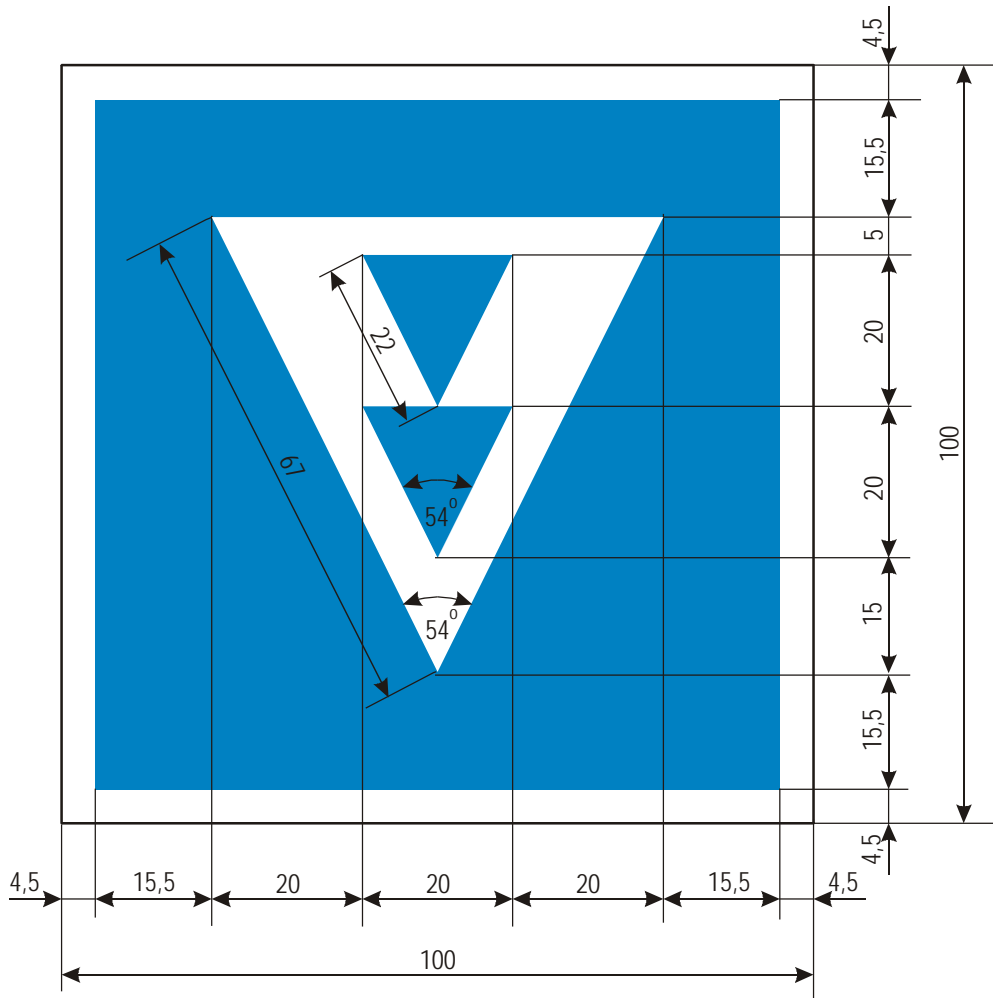

E.5.12 Berthing area reserved for all vessels that are not required to carry the marking prescribed in article 3.14 of CEVNI, on the side of the waterway on which the sign is placed

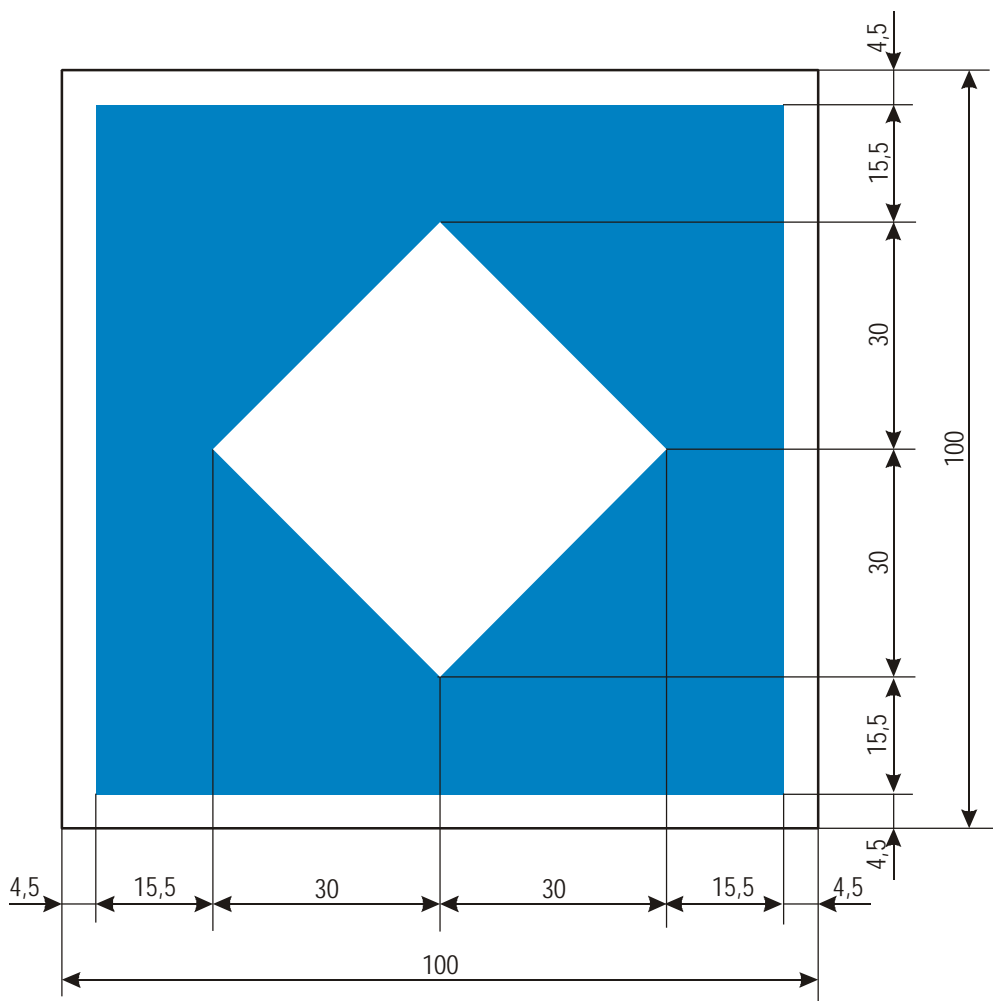

E.5.13 Berthing area reserved for all vessels that are required to carry one blue light or one blue cone under article 3.14, para. 1 of CEVNI, on the side of the waterway on which the sign is placed

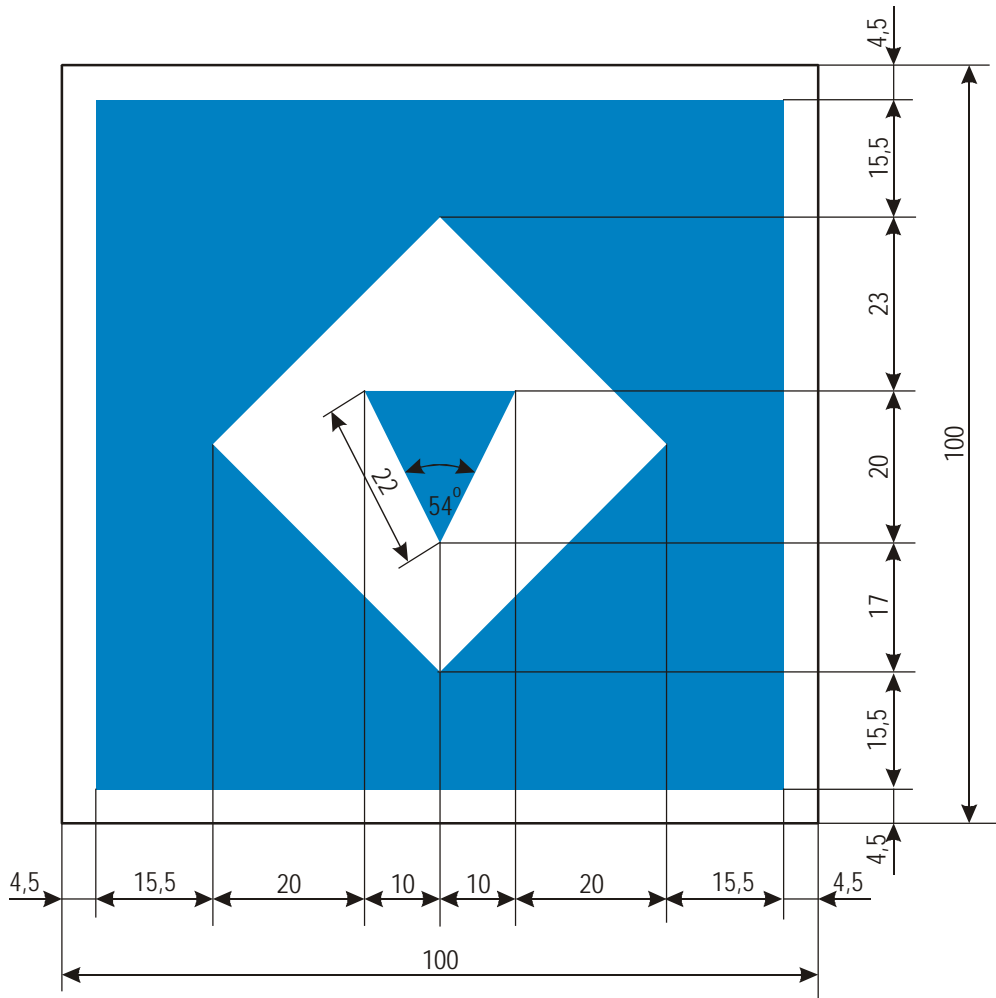

E.5.14 Berthing area reserved for all vessels that are required to carry two blue lights or two blue cones under article 3.14, para. 2 of CEVNI

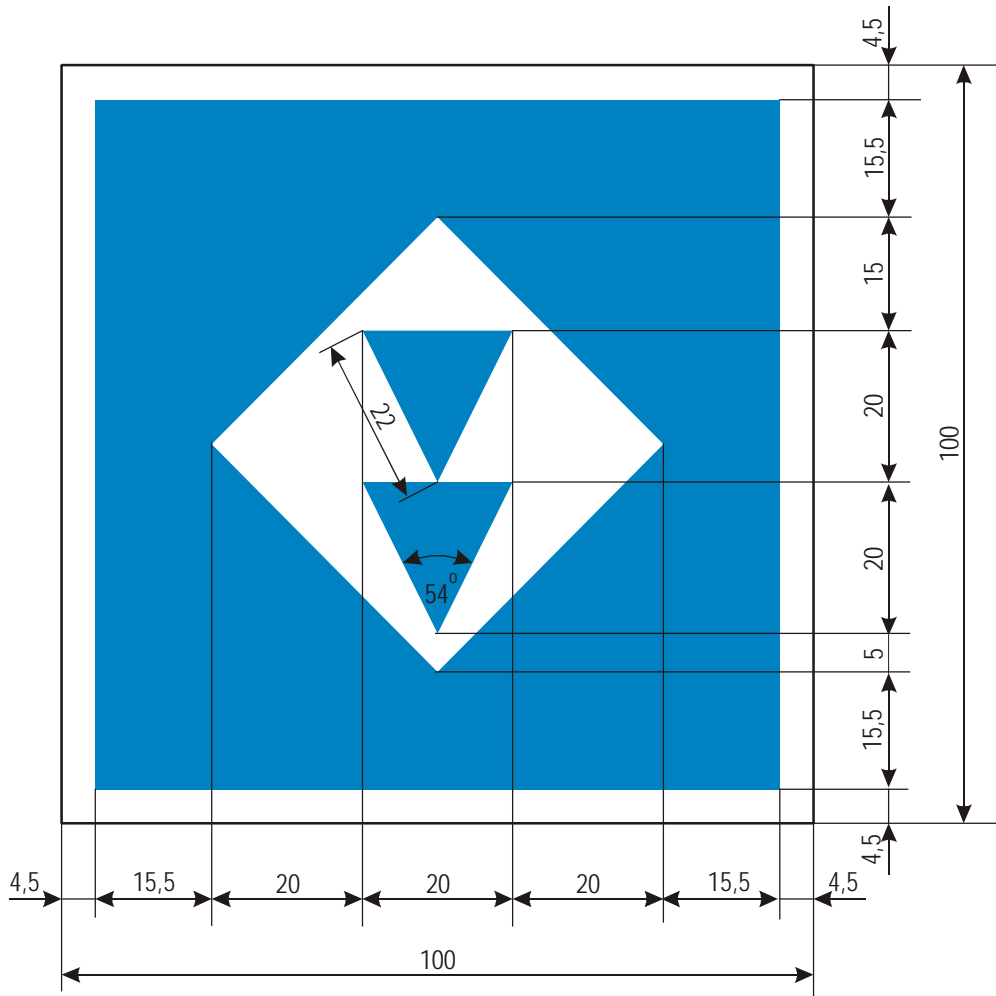

E.5.15 Berthing area reserved for all vessels that are required to carry three blue lights or three blue cones under article 3.14, para. 3 of CEVNI, on the side of the waterway on which the sign is placed

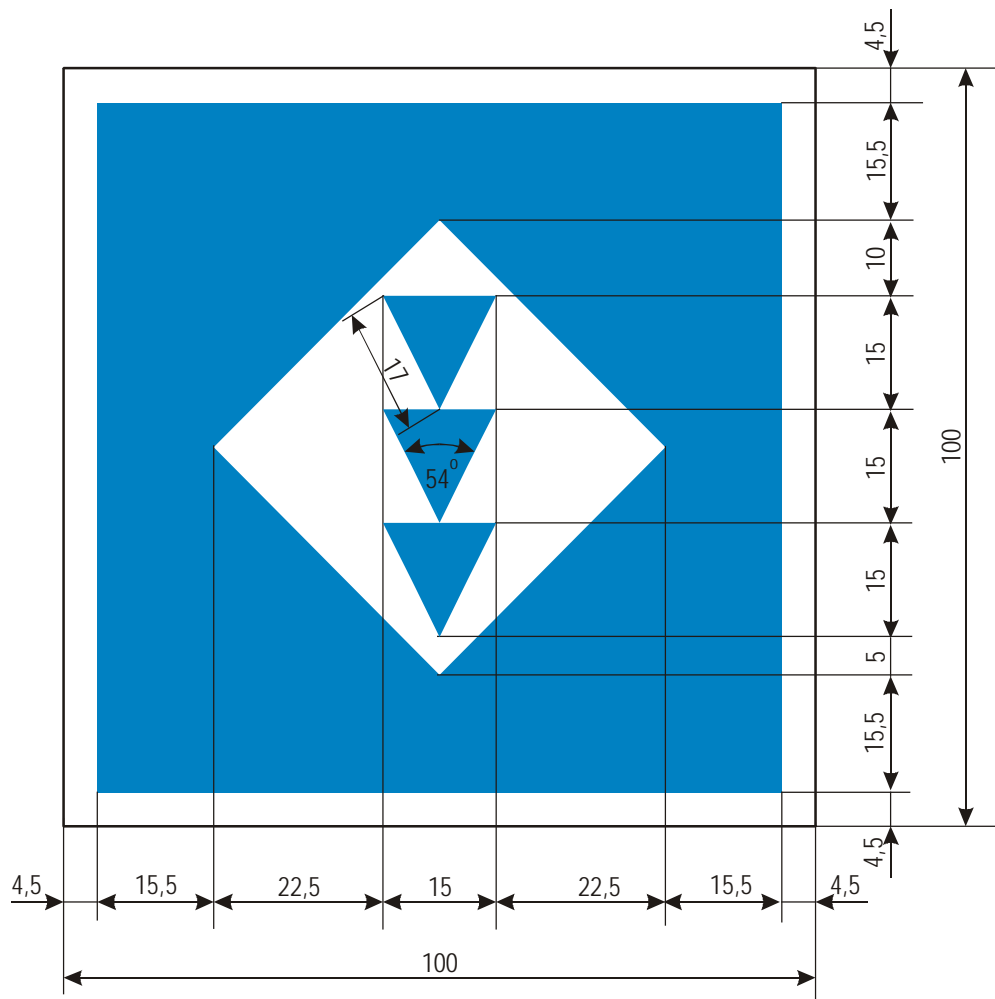

E.6 Anchoring or trailing of anchors, cables or chains permitted on the side of the waterway on which the sign is placed

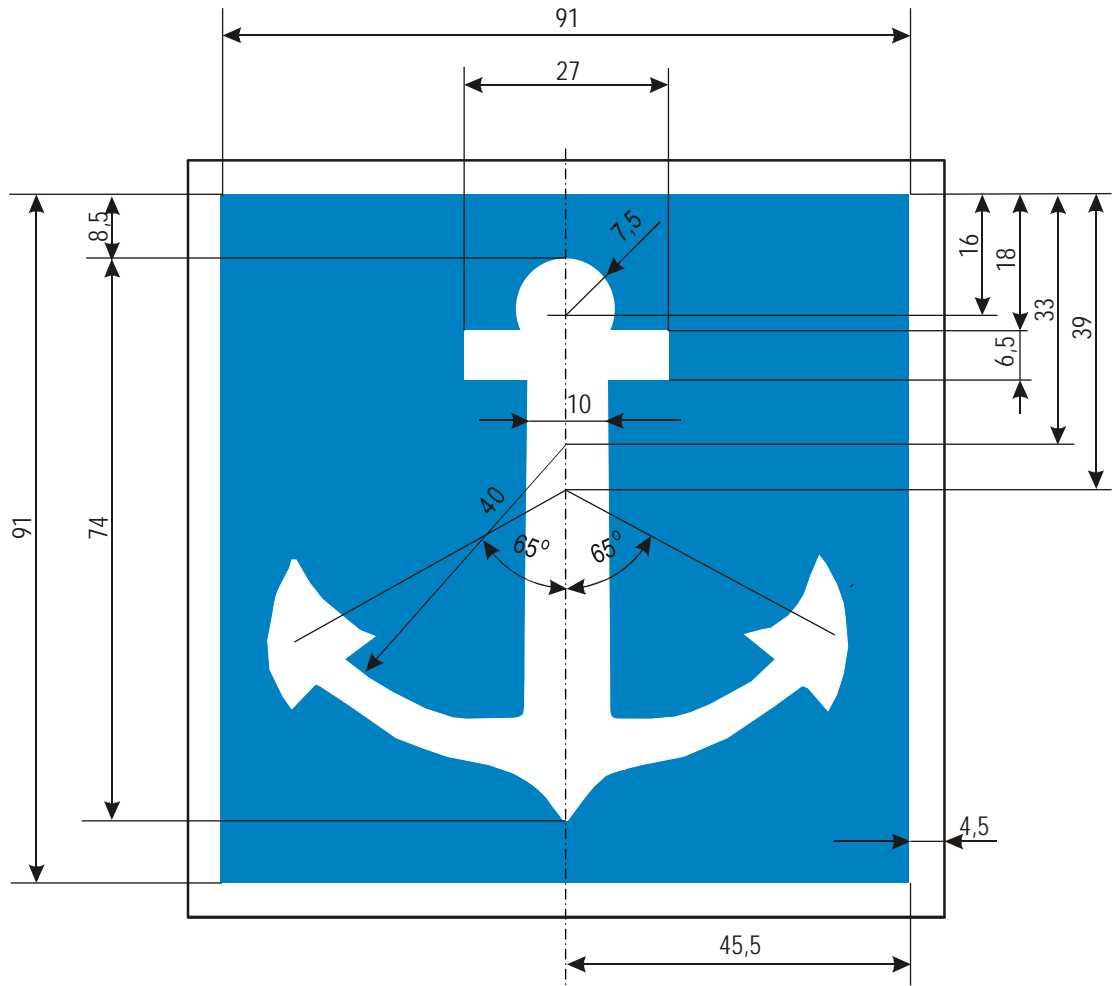

E.6.1 Use of spuds permitted

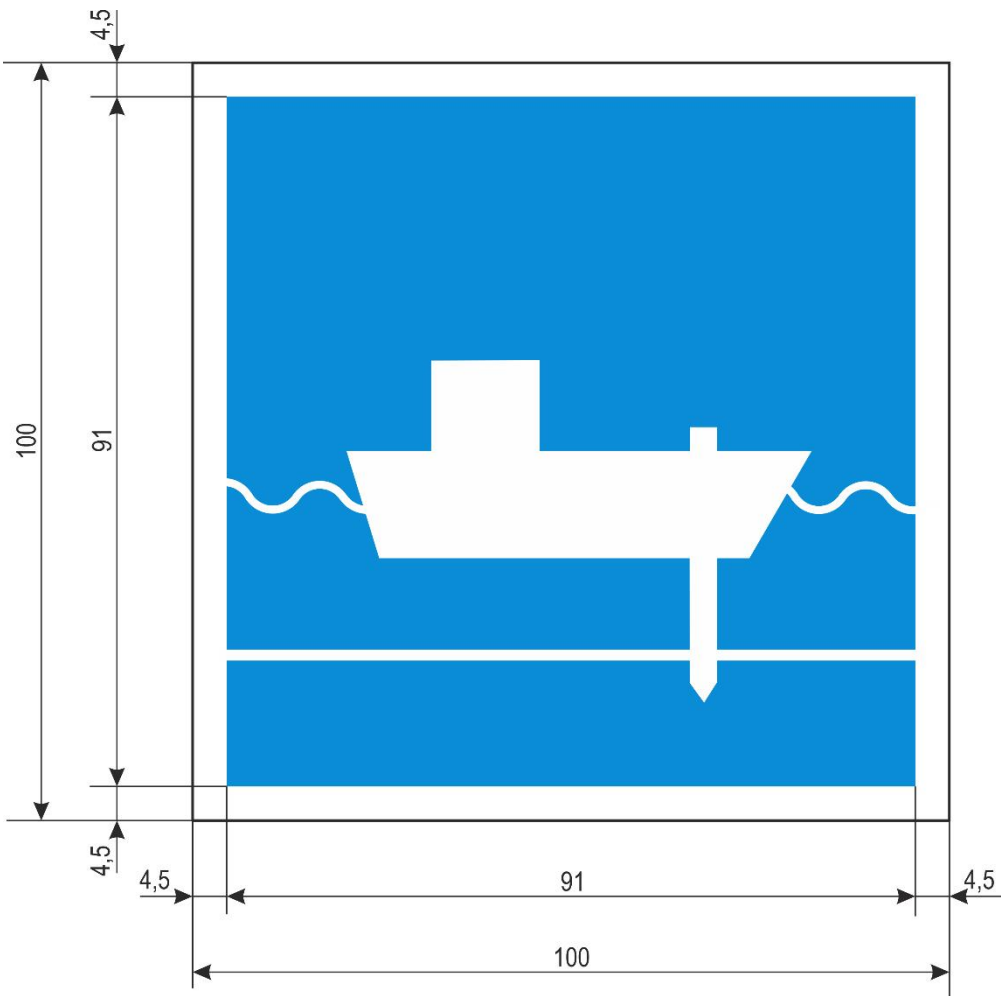

E.7 Making fast to the bank permitted on the side of the waterway on which the sign is placed

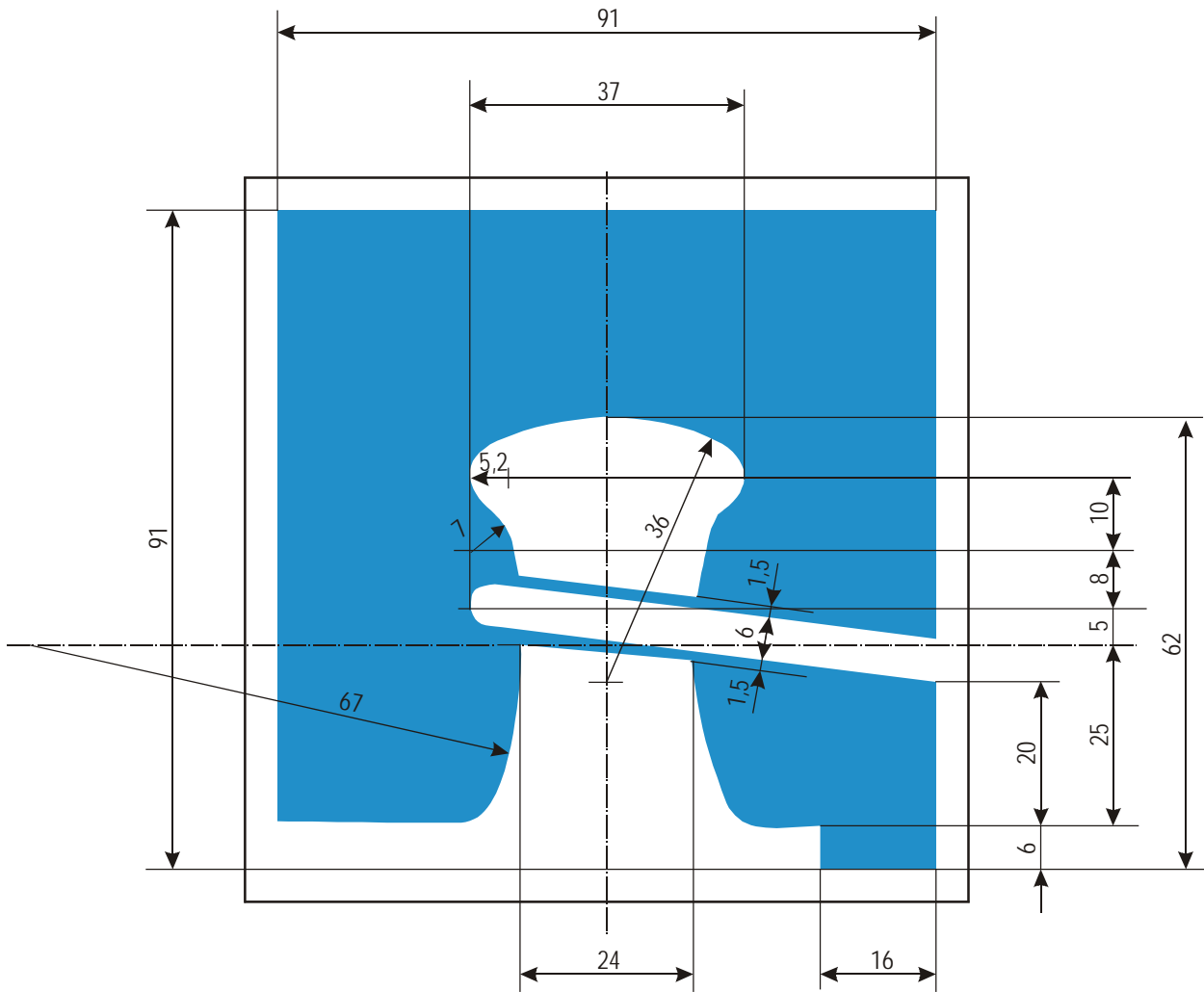

E.7.1 Berthing area reserved for loading and unloading vehicles

Maximum duration of berthing permitted may be added on an information plate below the board

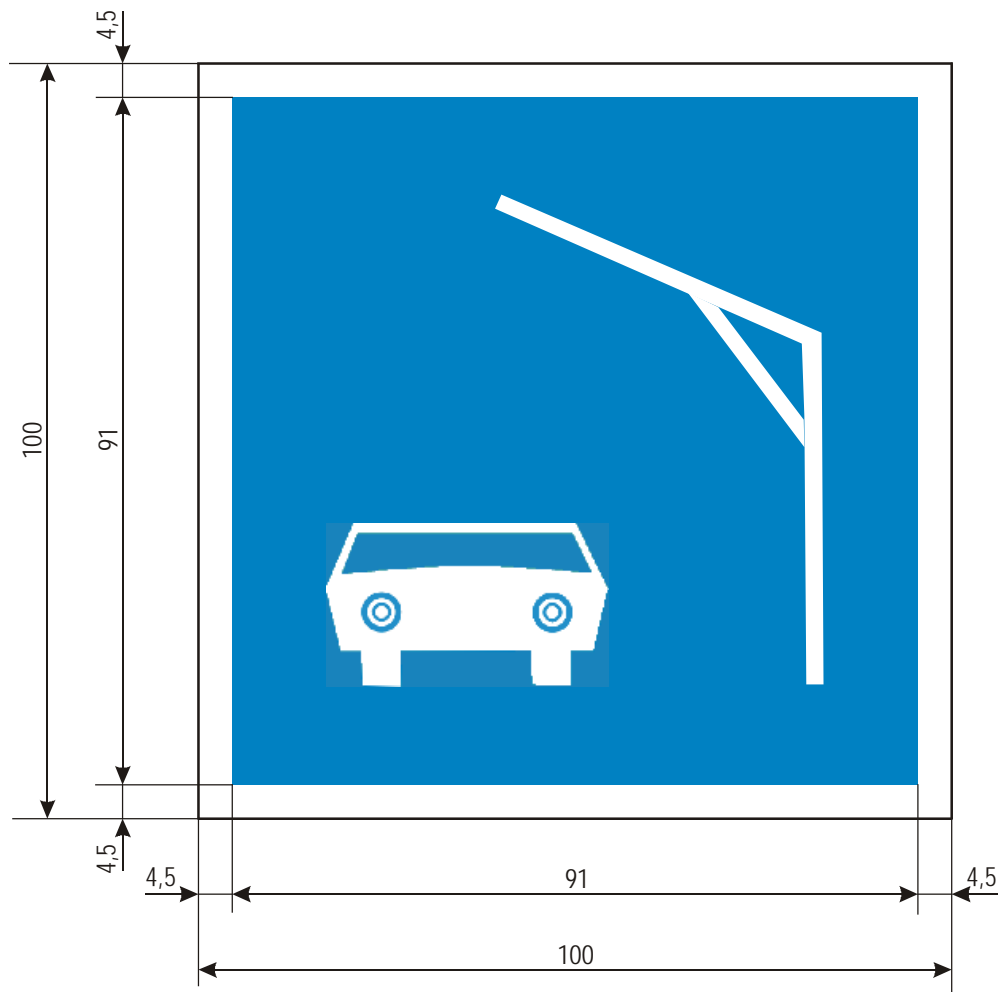

E.9 The waterways being approached are considered to be tributaries of this waterway
(a) E.9a

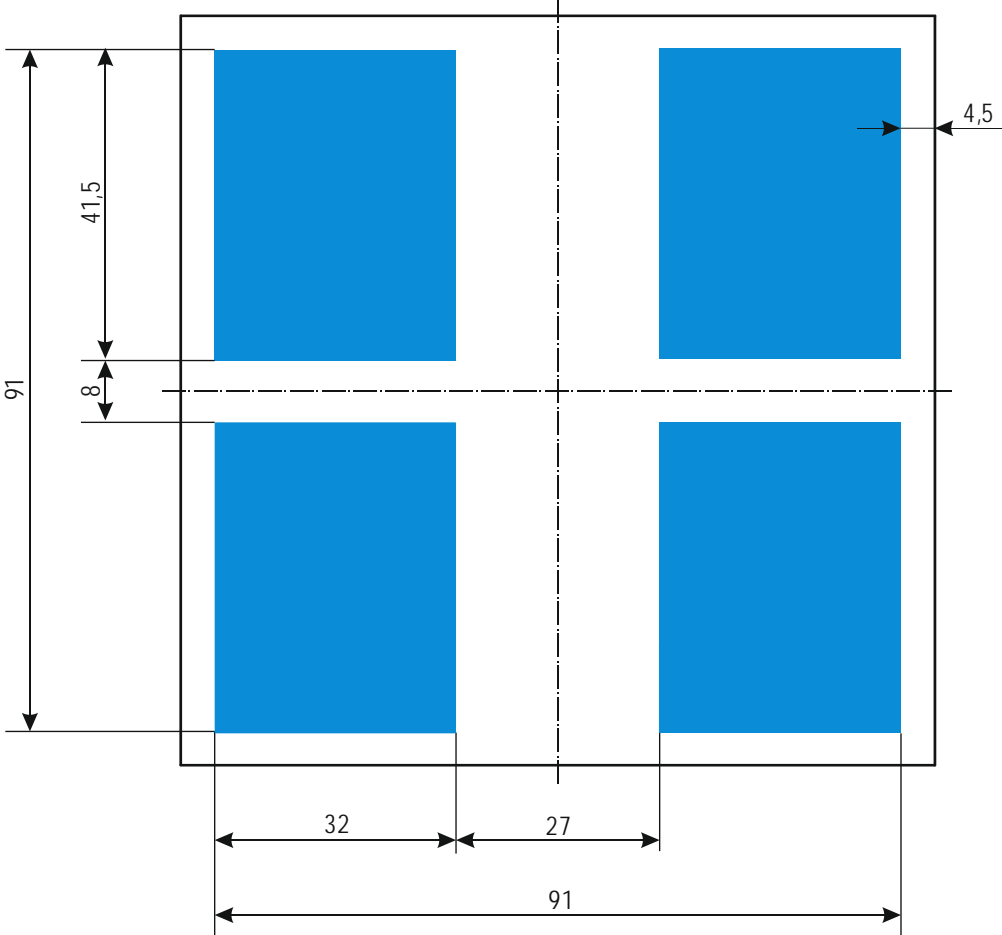

(b) E.9b

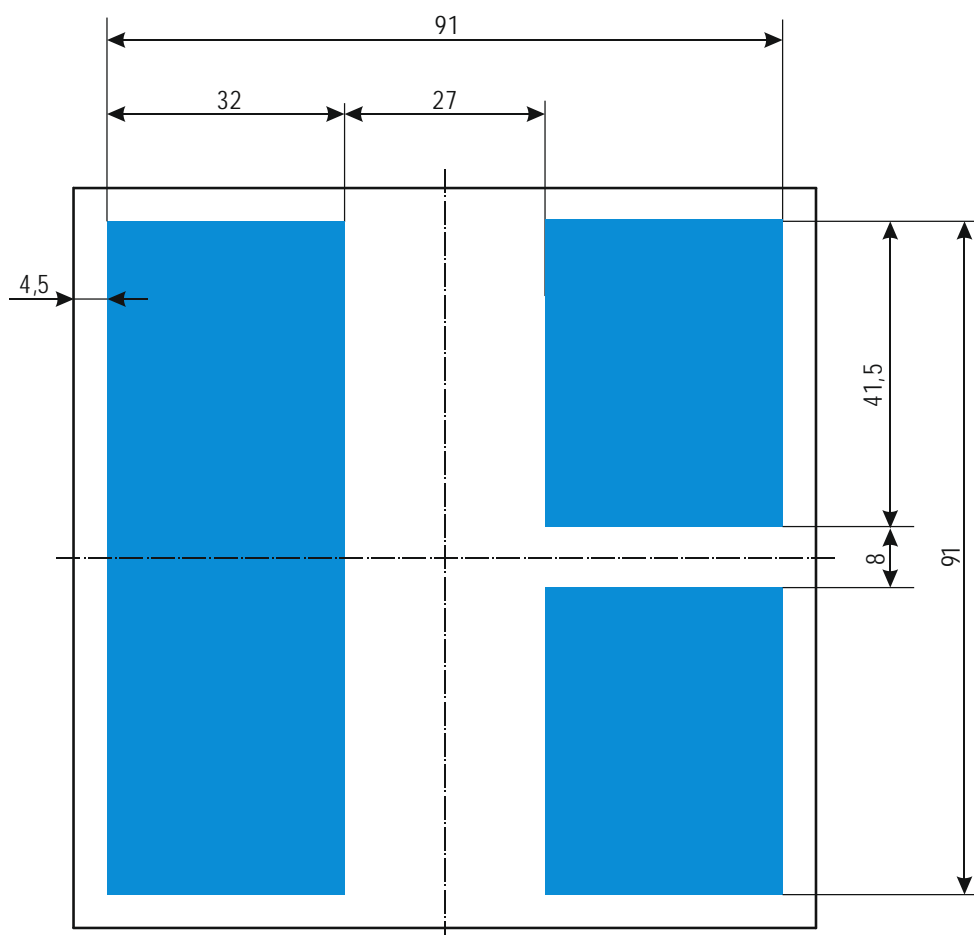

(c) E.9c

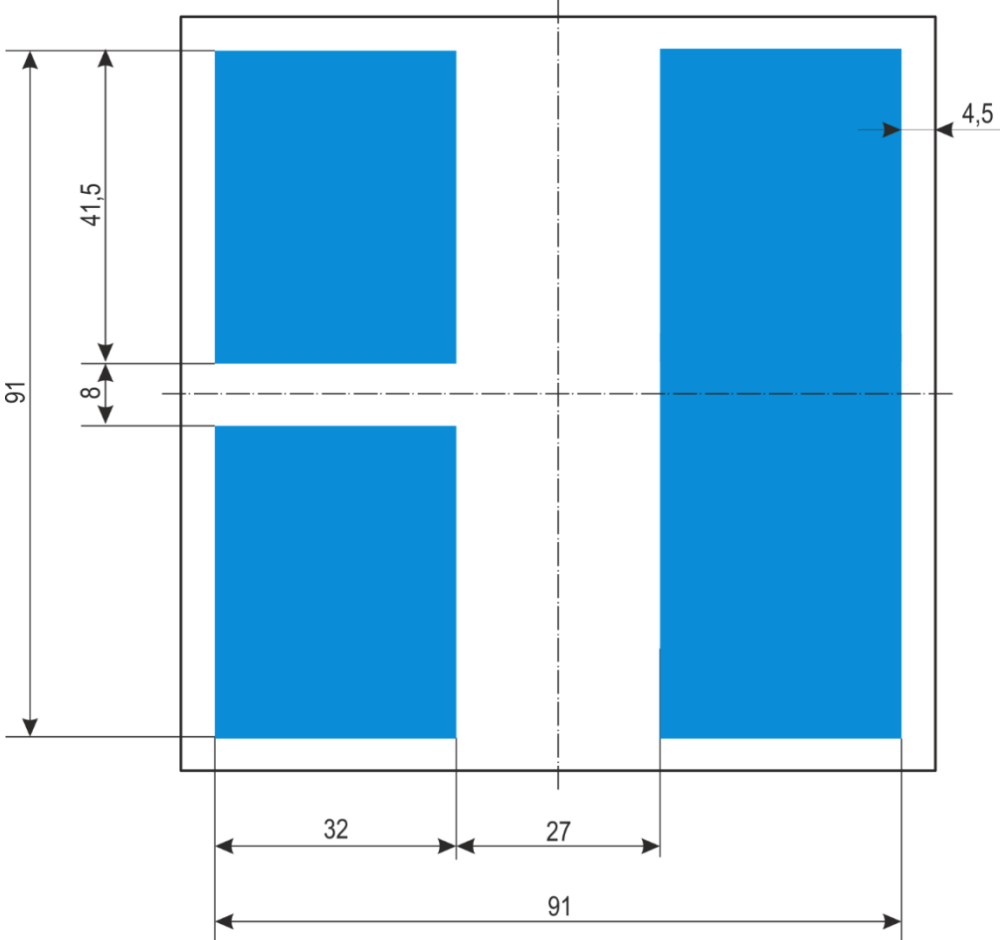

E.10 This waterway is considered to be a tributary of the waterway being approached

(a) E.10a

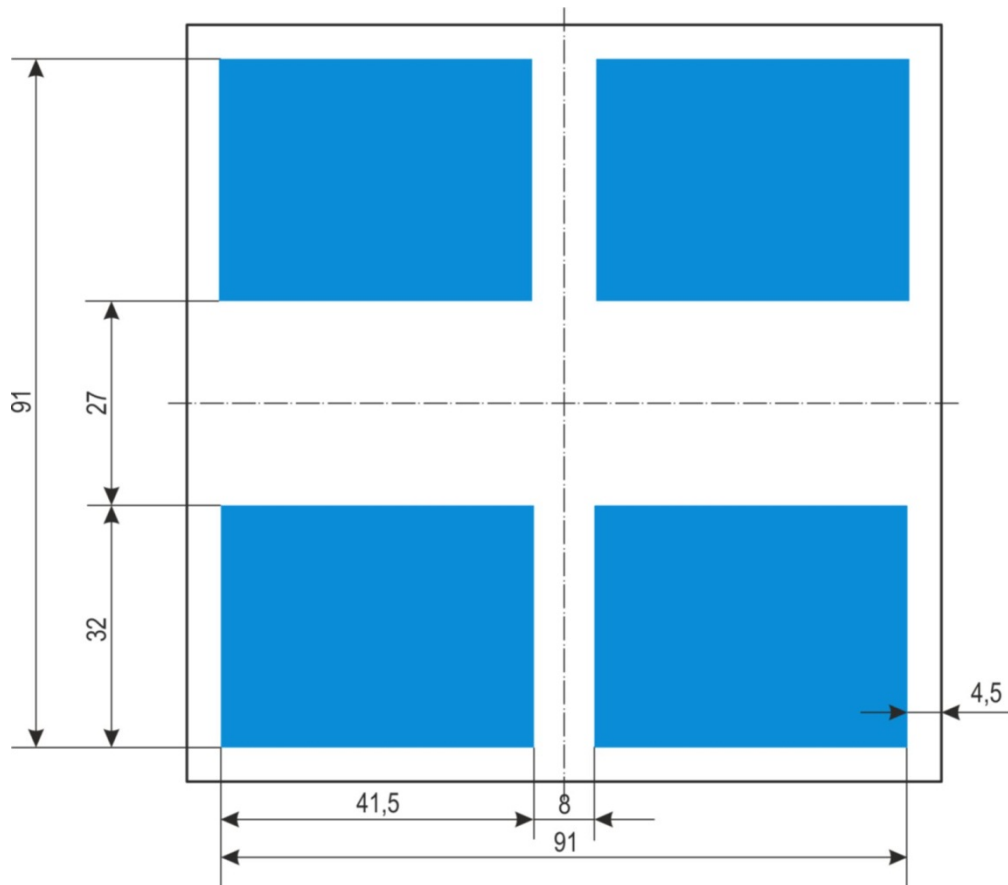

(b) E.10b

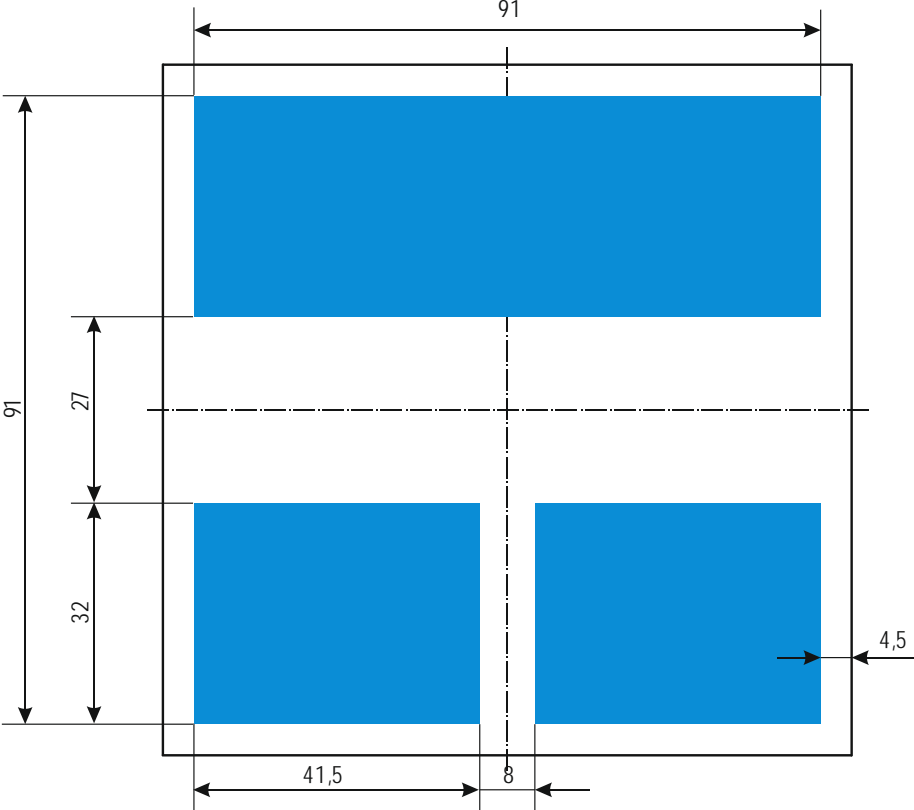

E.11 End of a prohibition or obligation applying to traffic in one direction only, or end of a restriction

(a) E.11a

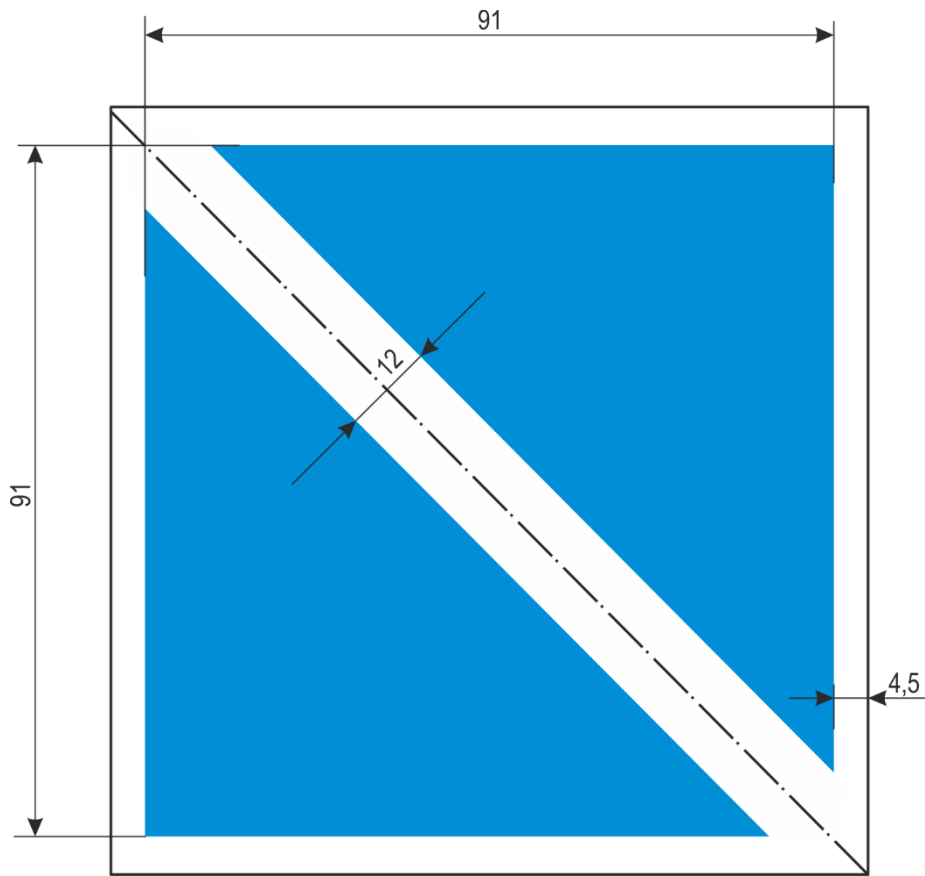

(b) E.11b

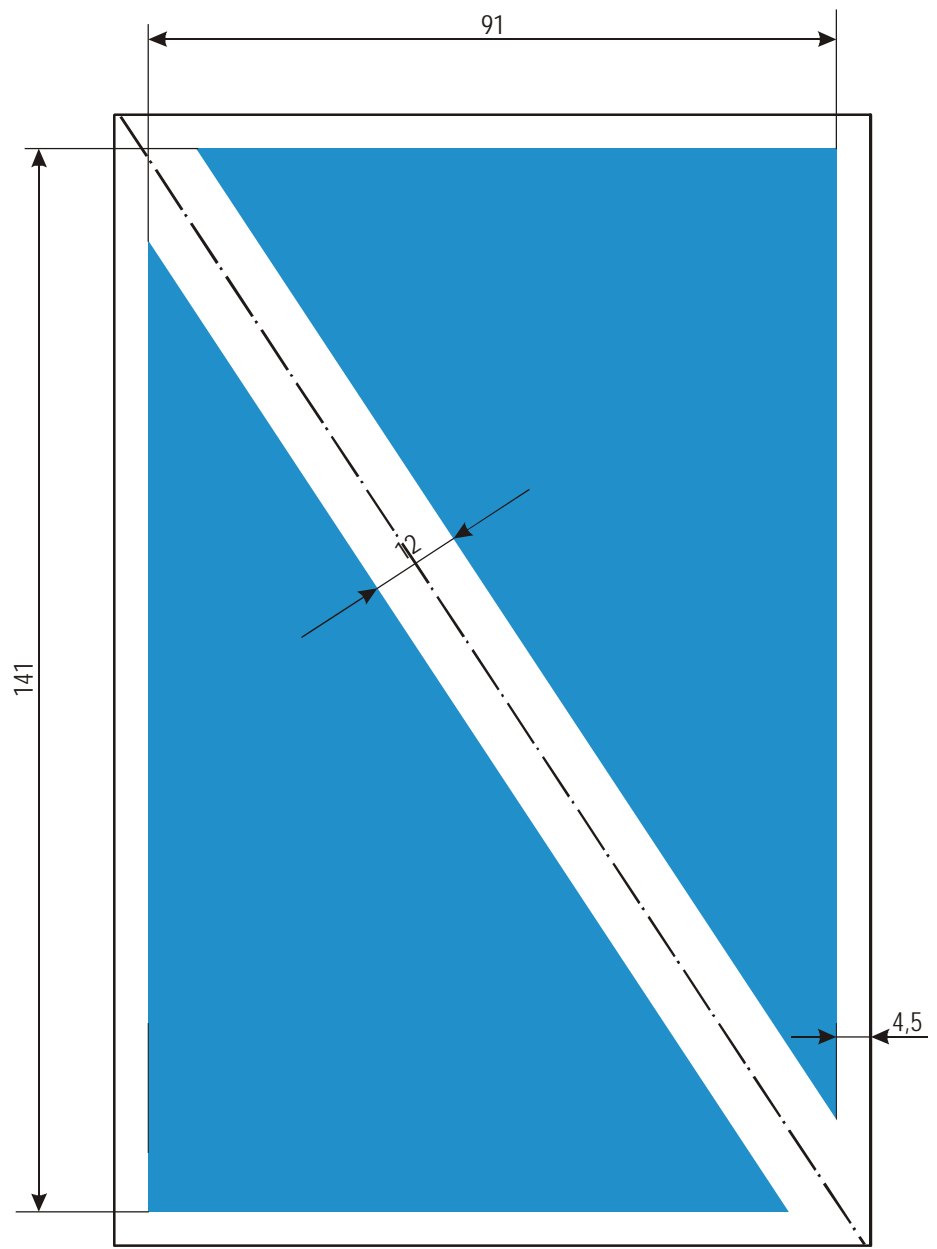

E.13 Drinking-water supply

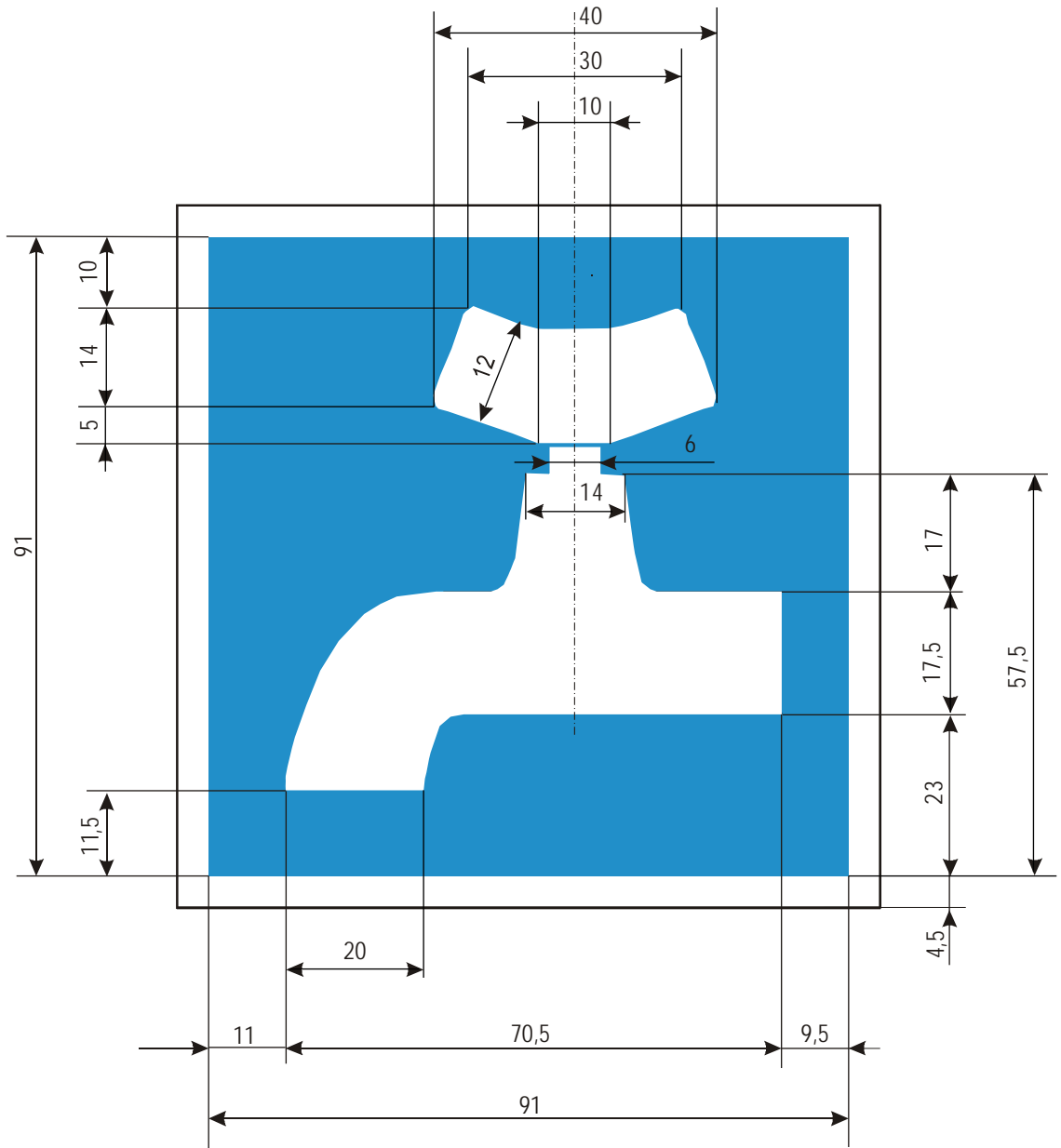

E.14 Telephone

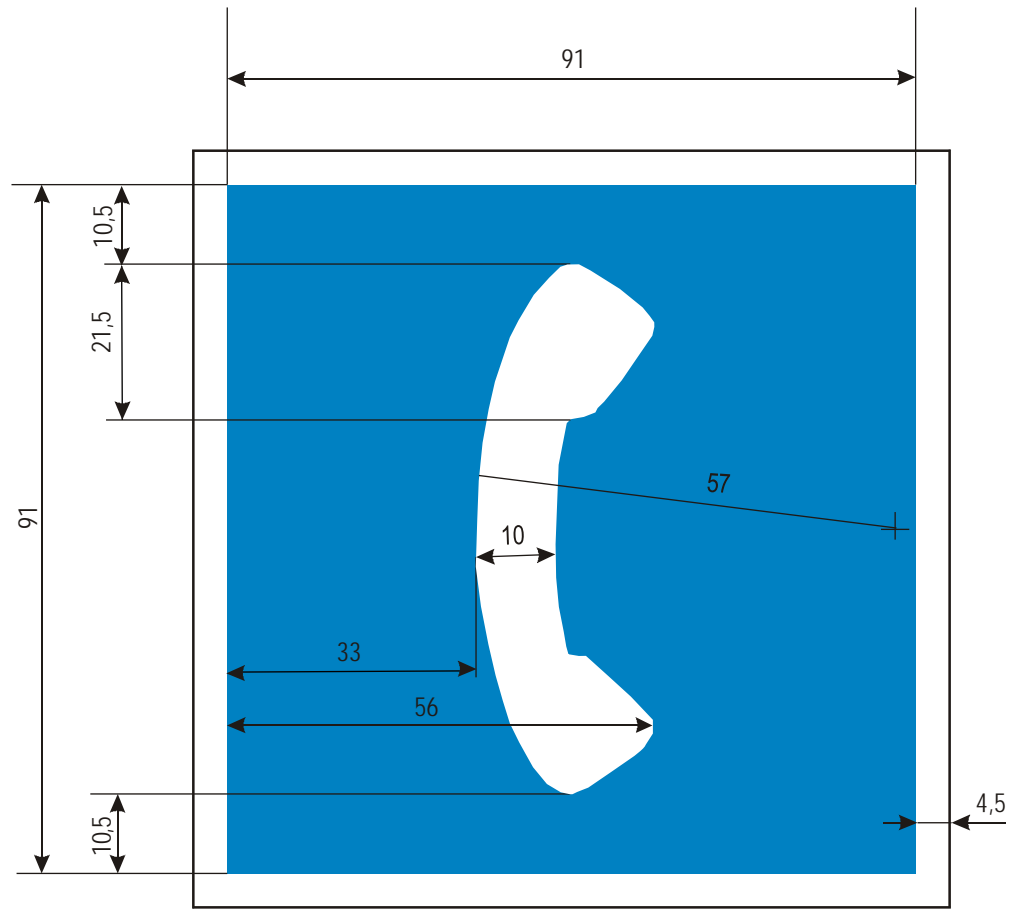

E.15 Motorized vessels permitted

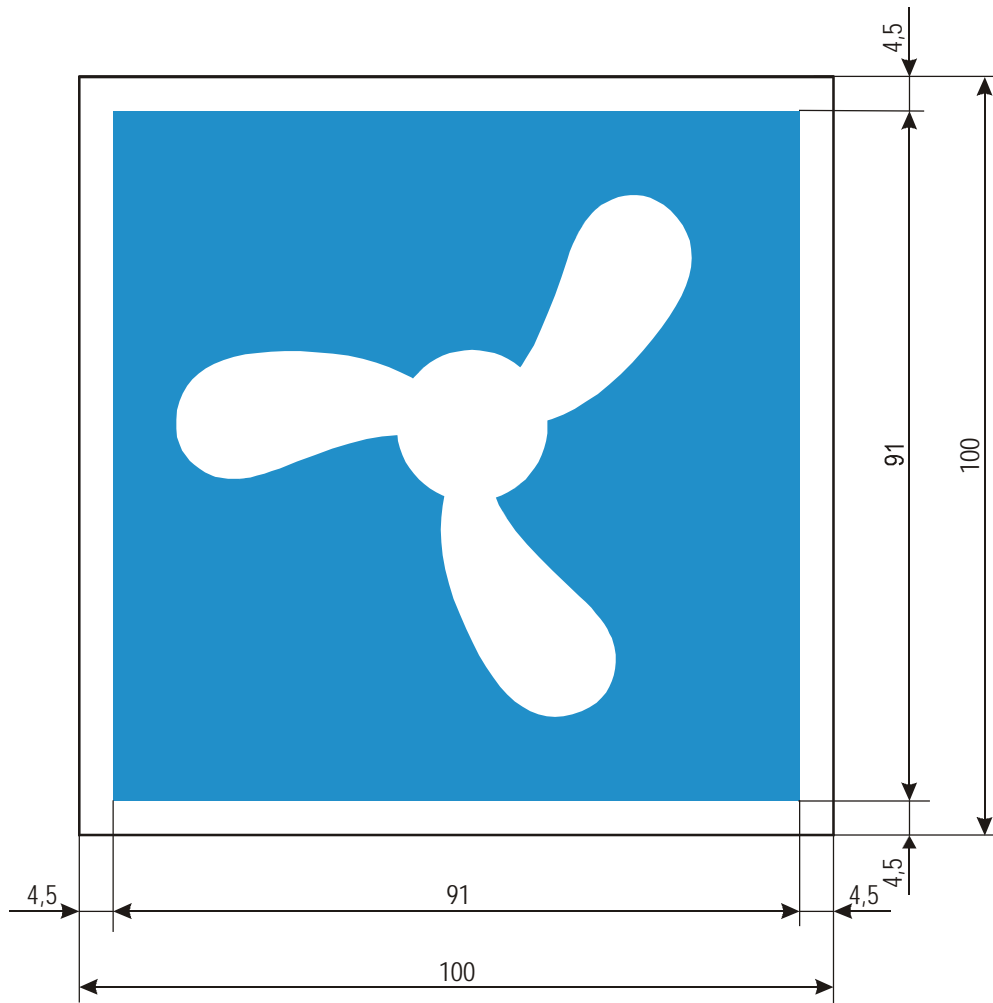

E.16 Sports or pleasure craft permitted

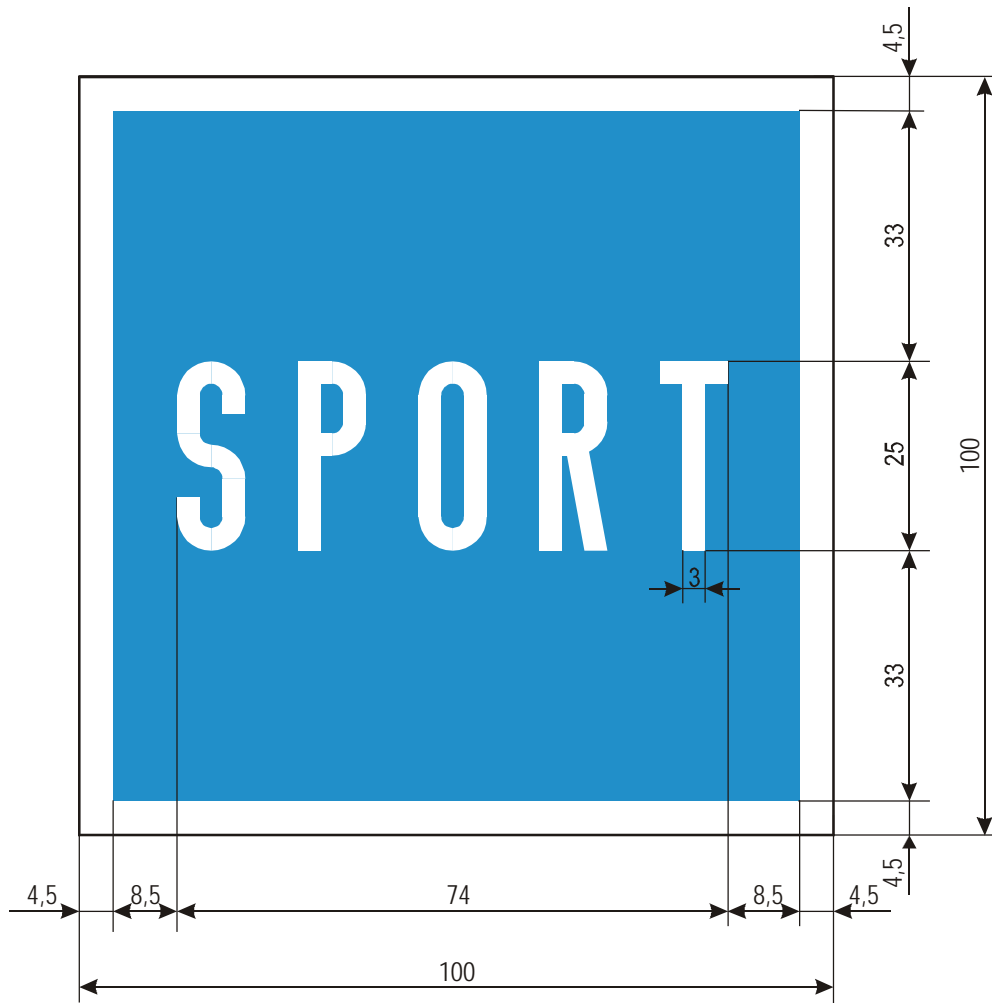

E.17 Water skiing permitted

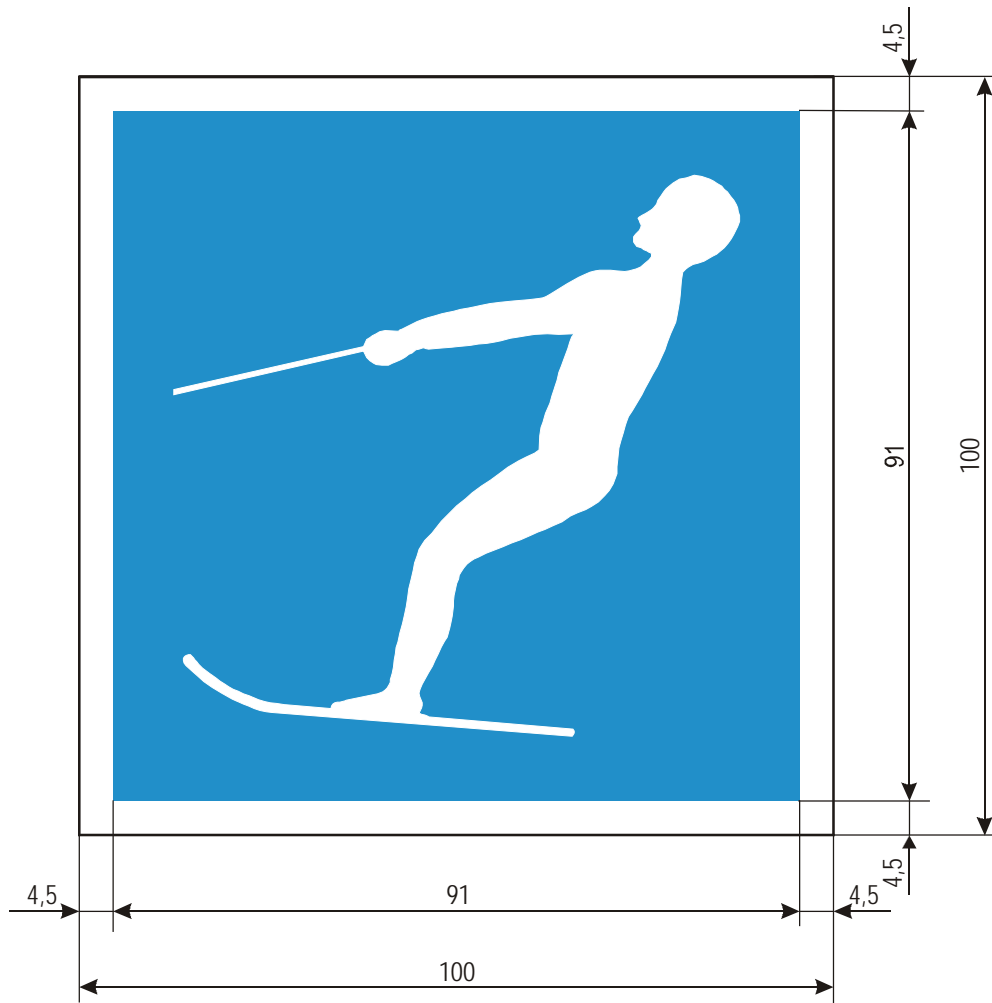

E.18 Sailing vessels permitted

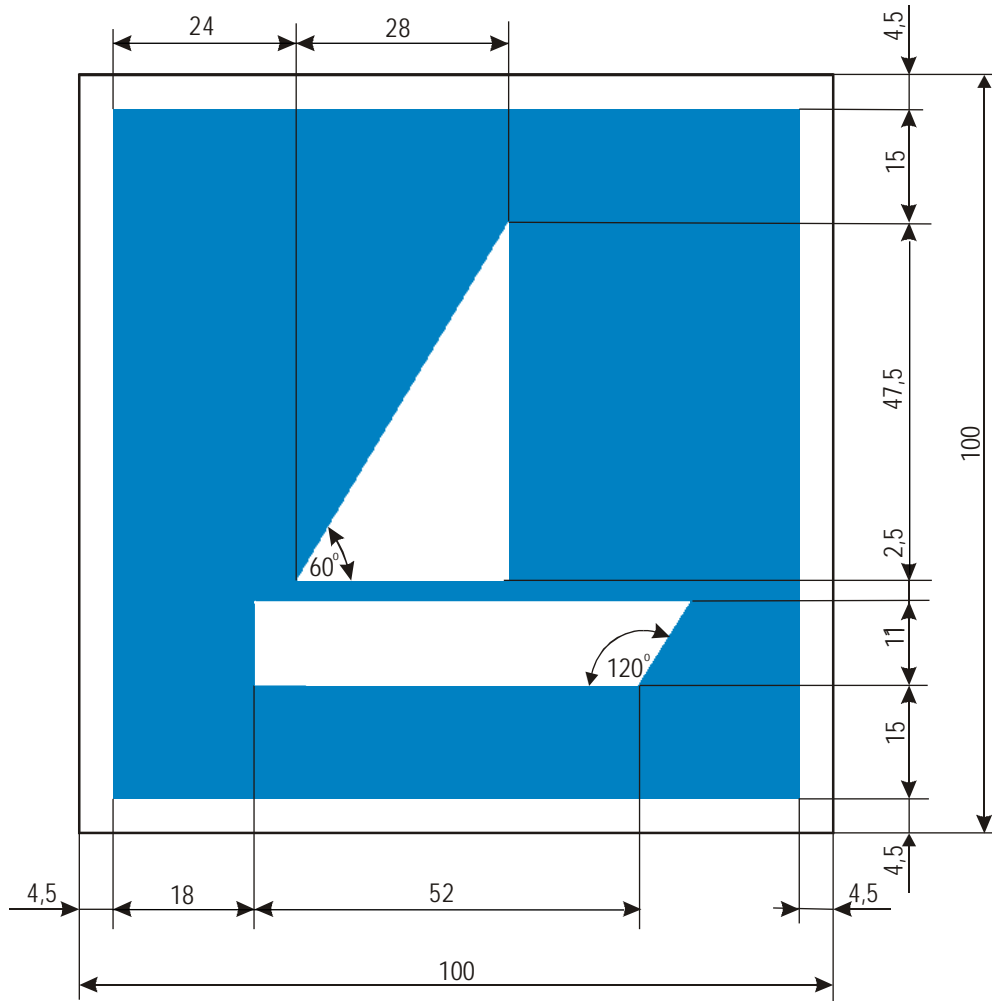

E.19 Craft other than motorized vessels or sailing craft permitted

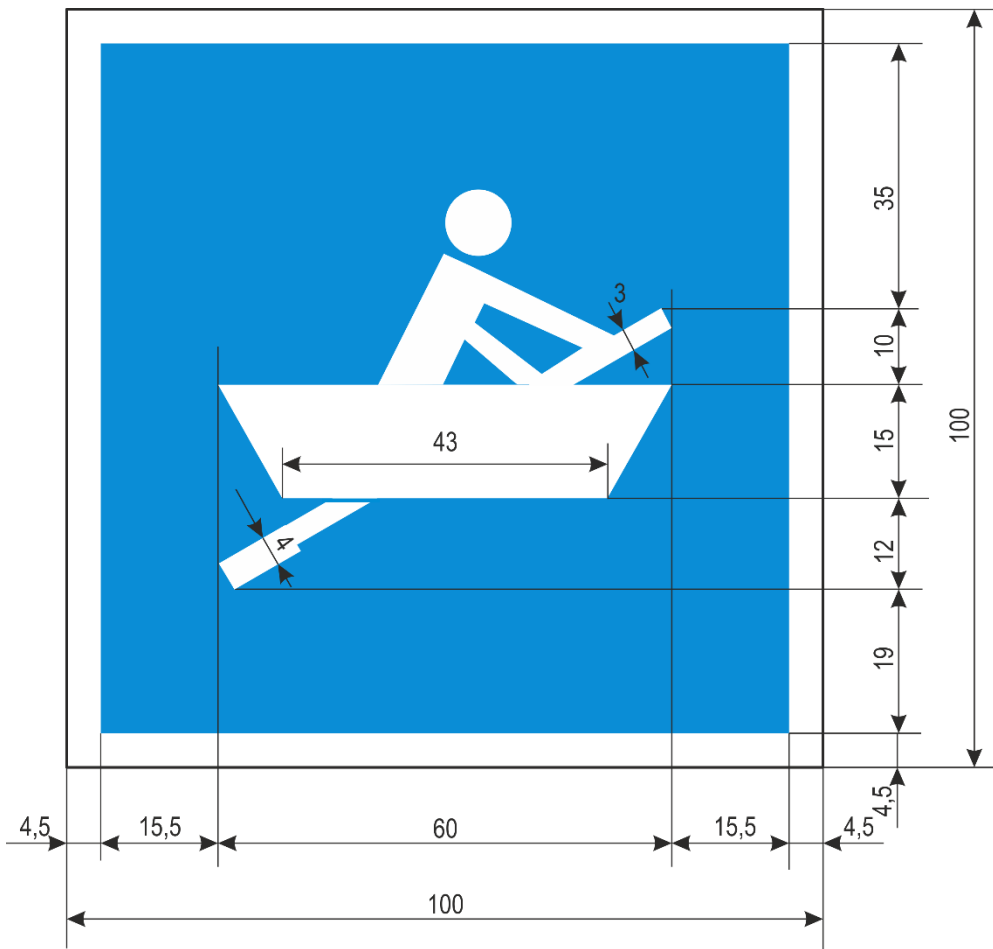

E.20 Use of sailboards permitted

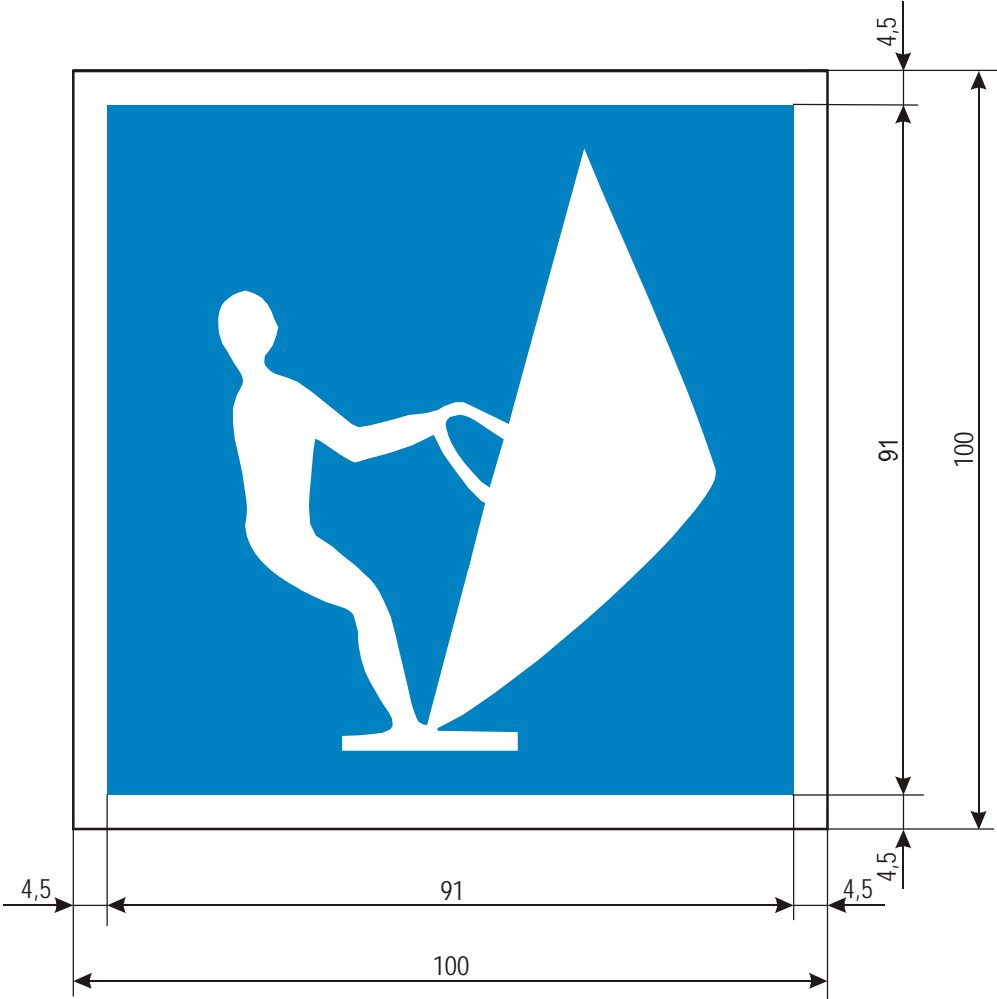

E.21 Zone authorized for high speed navigation of small sport and pleasure craft

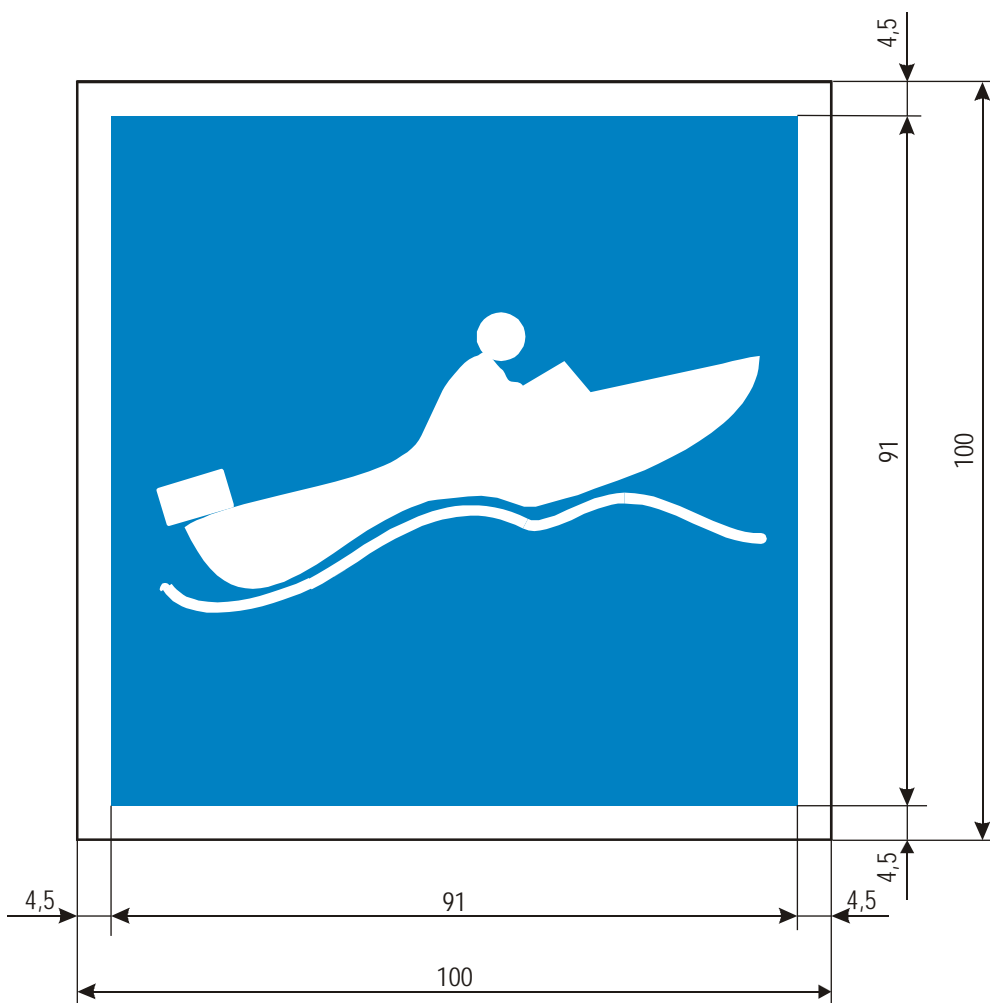

E.22 Launching or beaching of small craft permitted

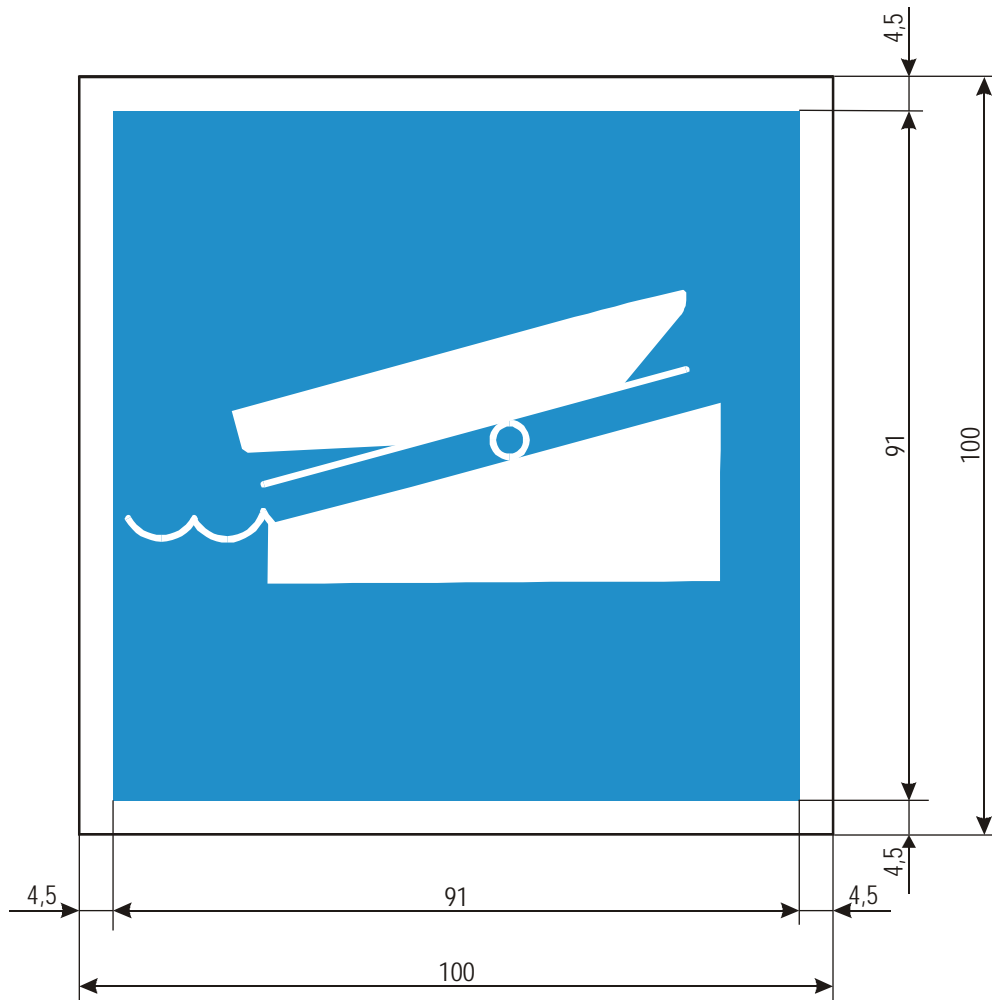

E.23 Possibility of obtaining nautical information by radio-telephone on the channel indicated

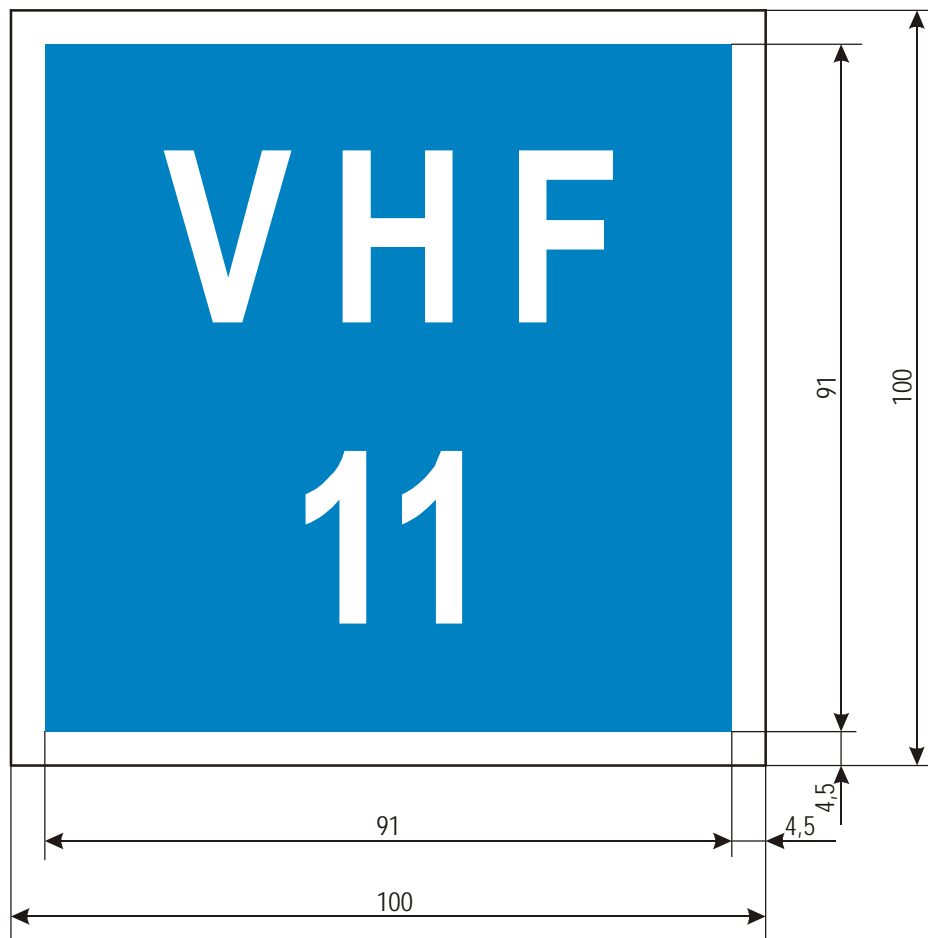

E.24 Water bikes permitted

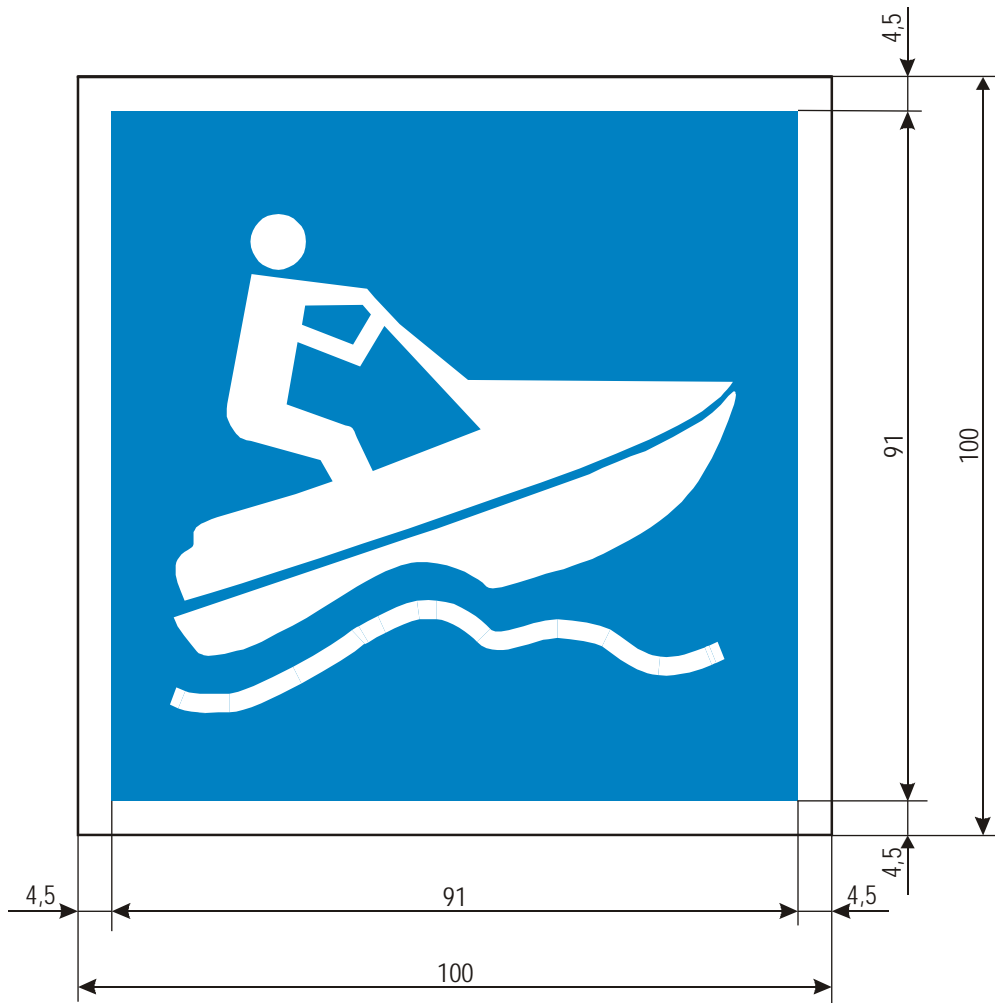

E.25 Electrical power supply point

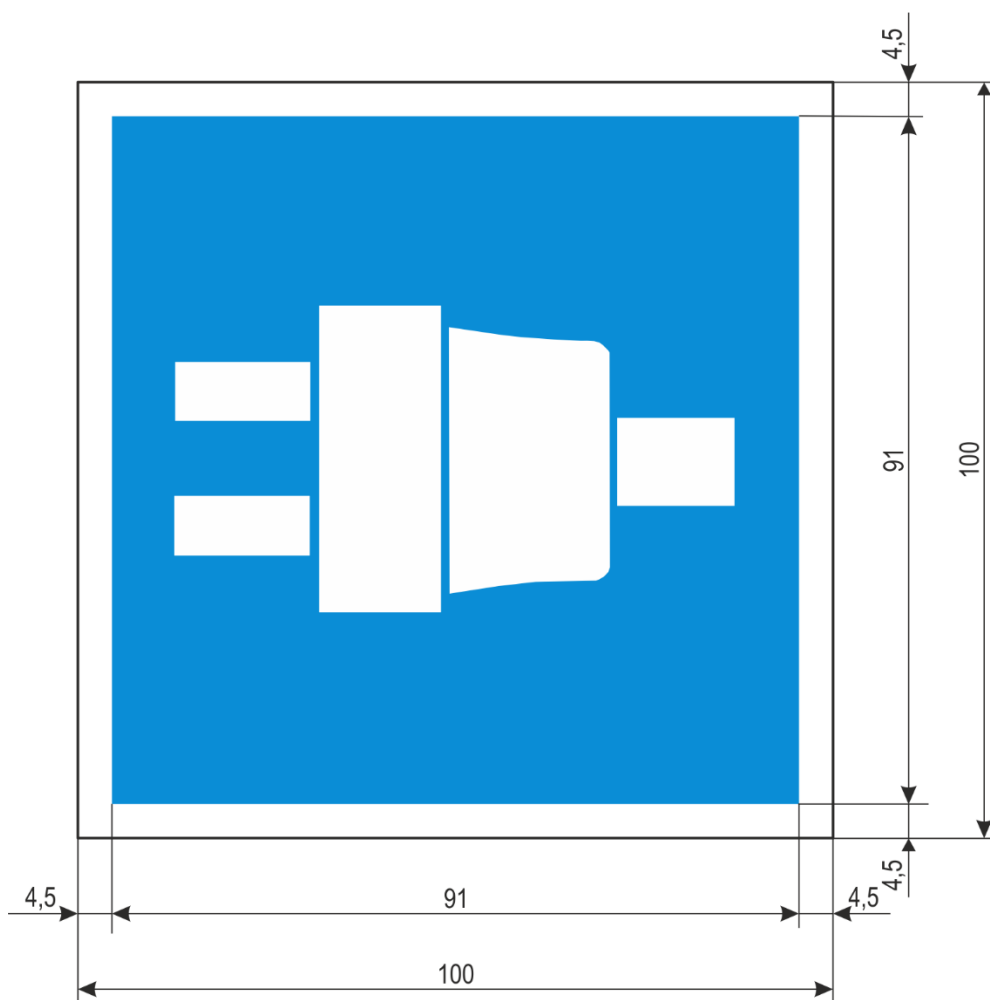

E.26 Winter harbour

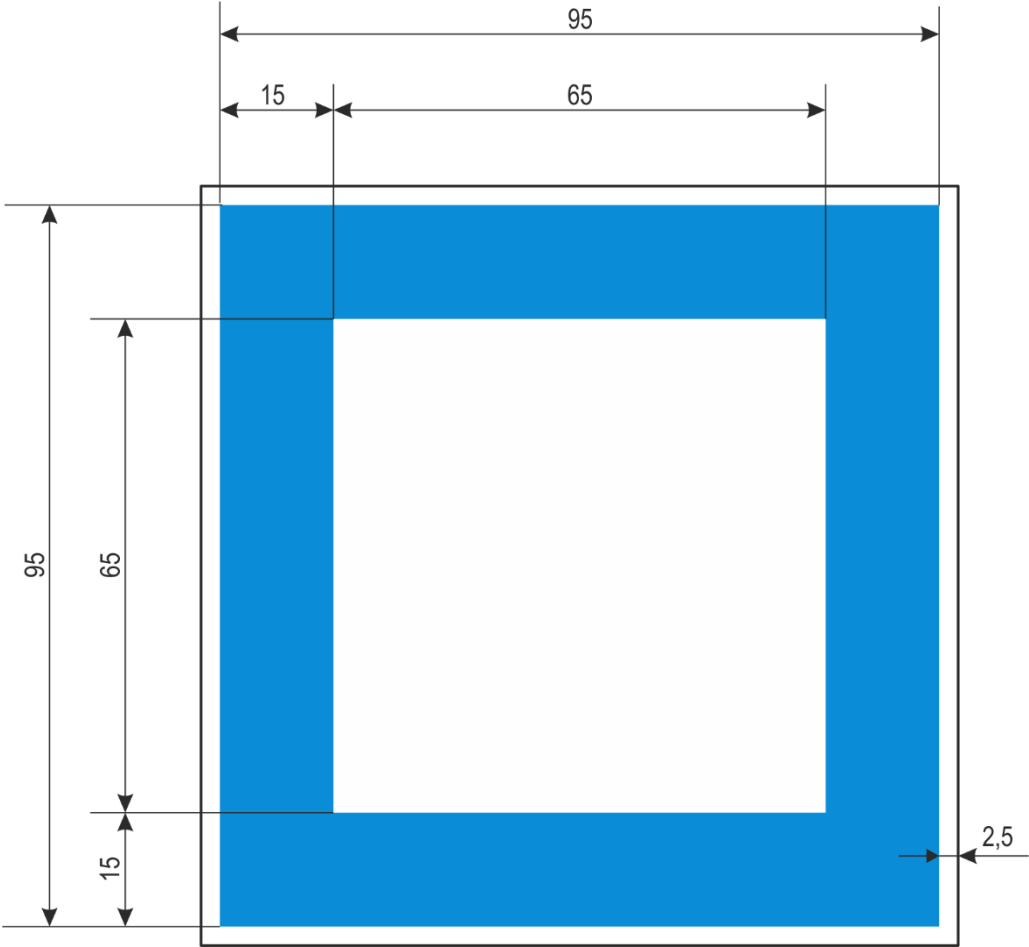

E.26.1 Maximum number of vessels permitted to berth in winter harbour

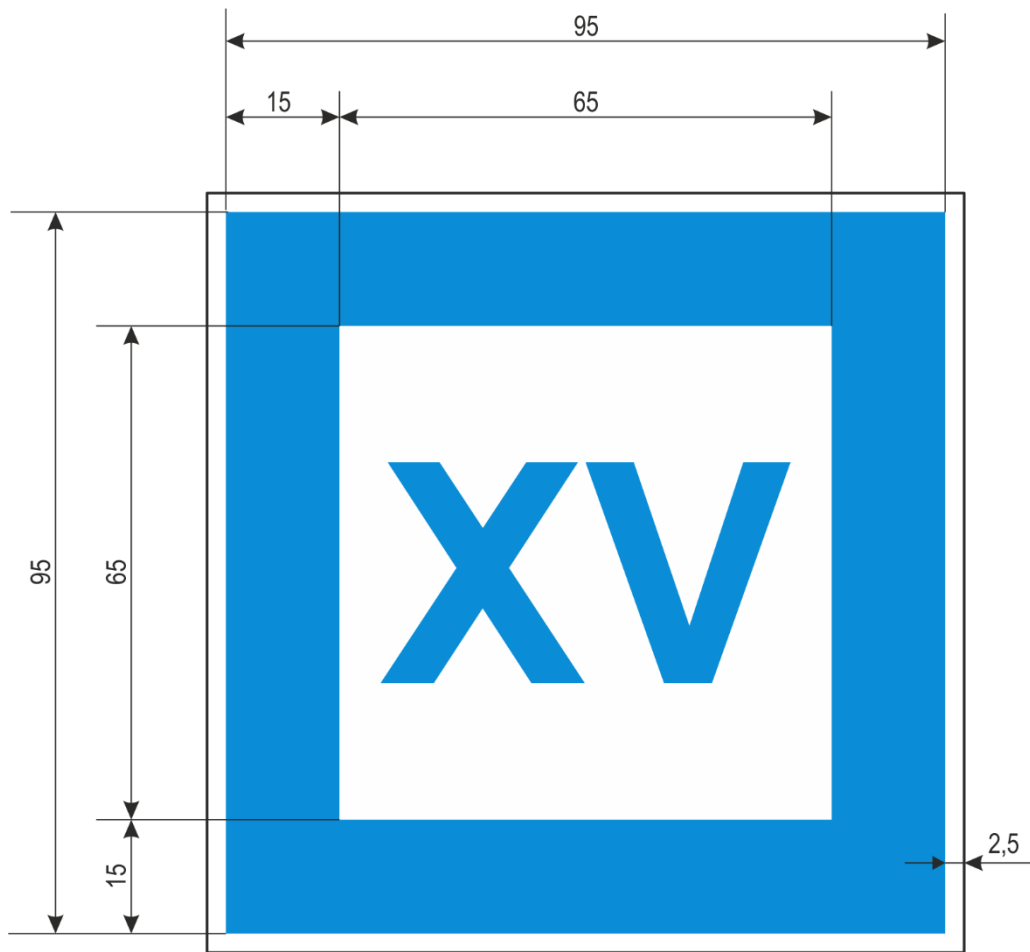

E.27 Winter shelter

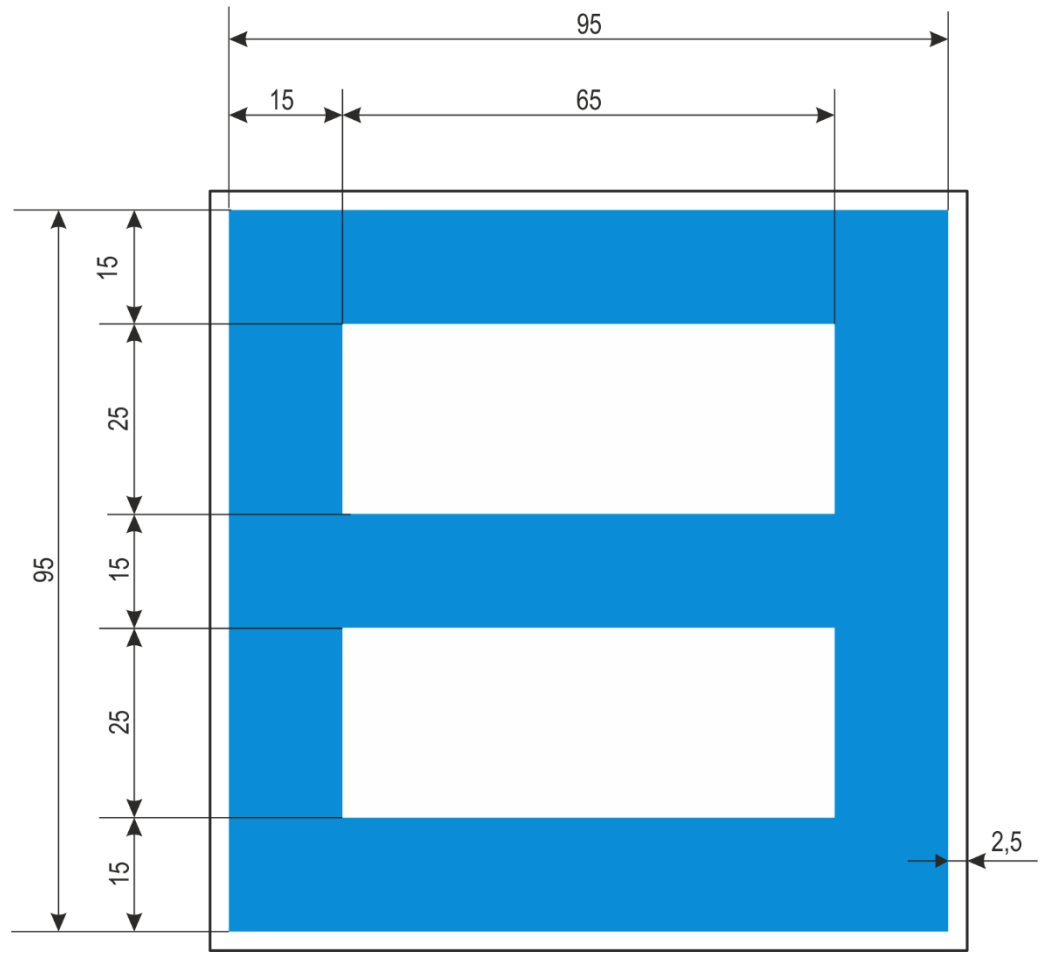

- E.27.1 Maximum number of vessels permitted to berth in winter shelter
Maximum number of vessels permitted to berth abreast
Maximum number of rows of vessels which are berthed abreast

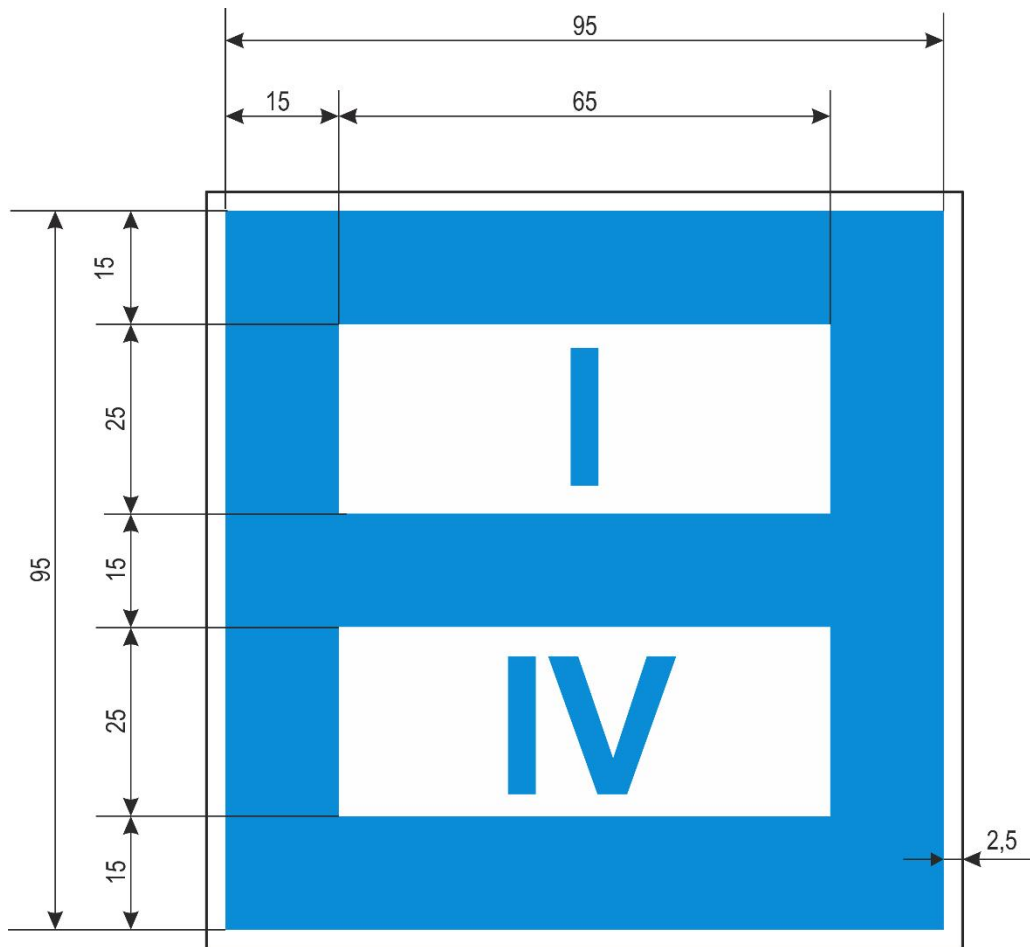

2.2 Auxiliary signs

- A. *Panels showing the distance at which the regulation applies or the special feature indicated by the main sign is to be found*

Example 1

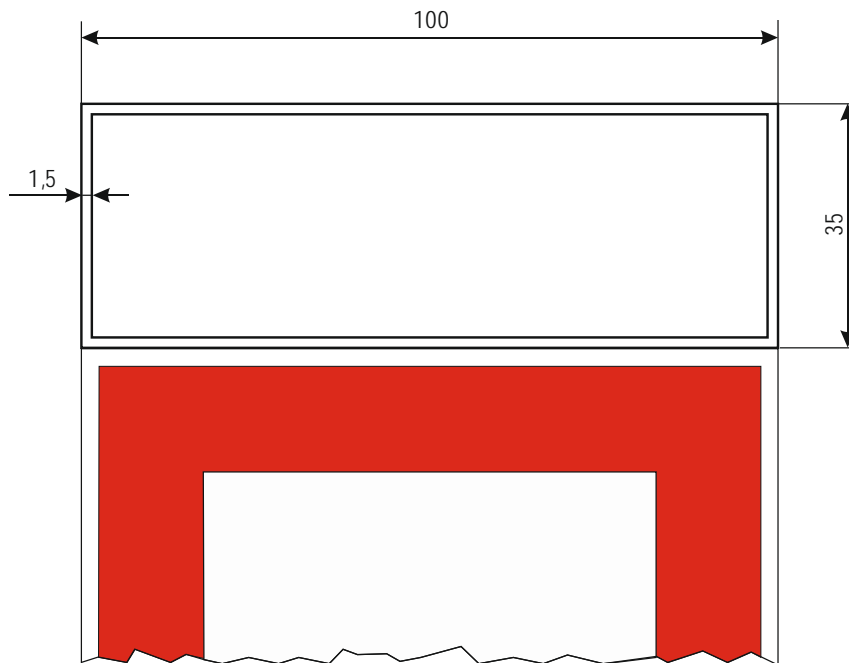

Example 2

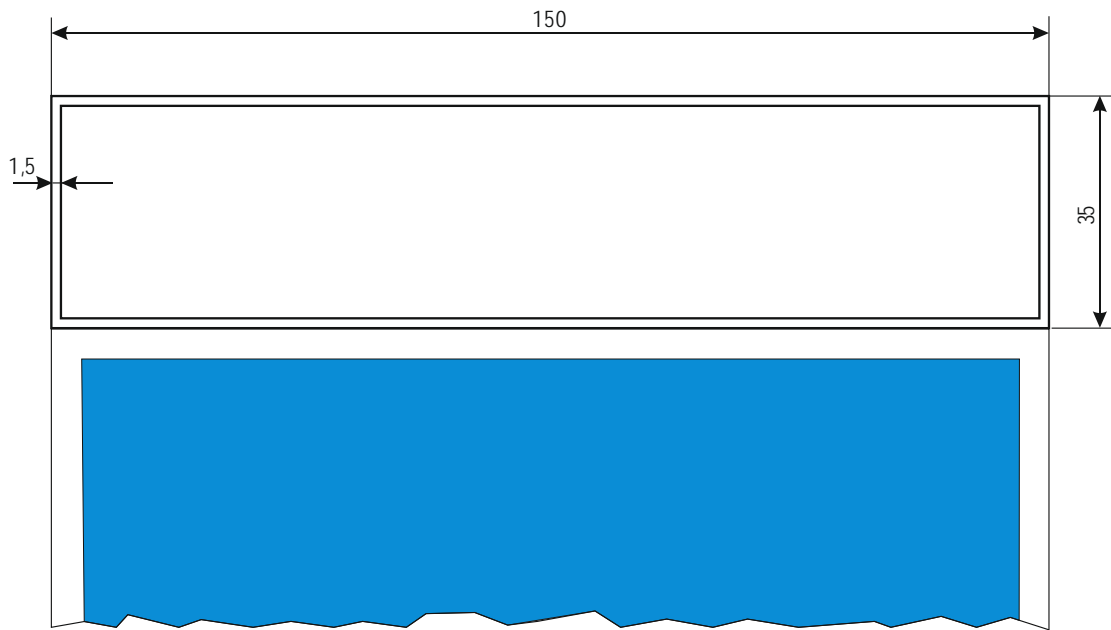

B. Pointers showing the direction of the section to which the main sign applies

Example

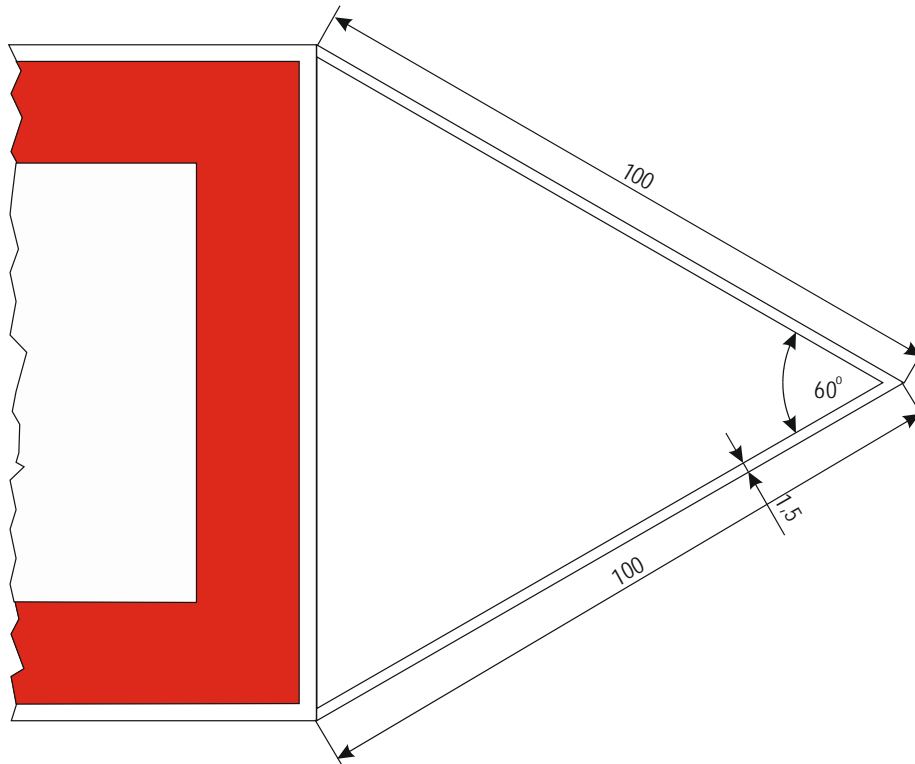

C. Panels giving explanations or additional information

Example

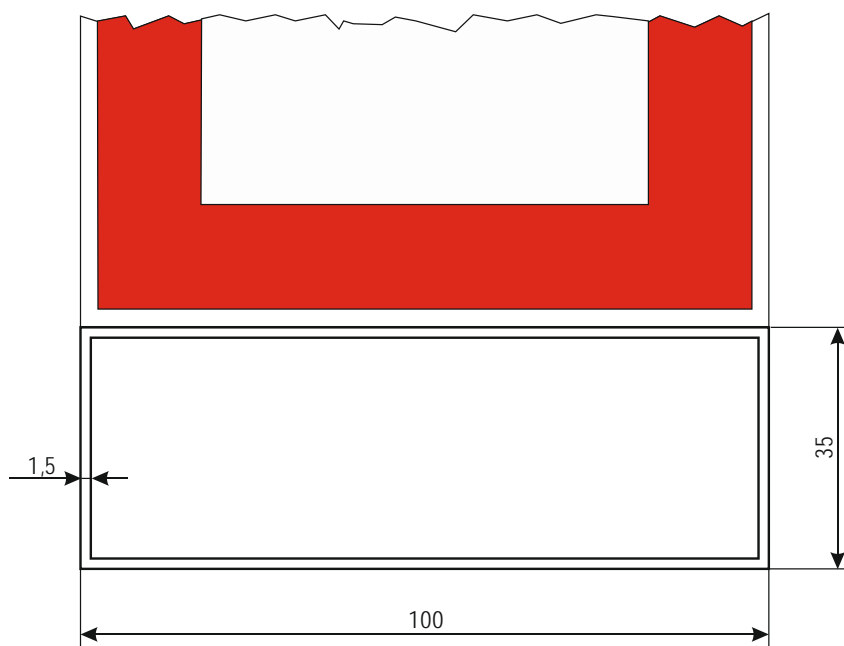

3. Minimal dimensions of the signs contained in annex 8 to the European Code for Inland Waterways

3.1 Buoyage of fairway limits in the waterway

A. Right-hand side of the waterway

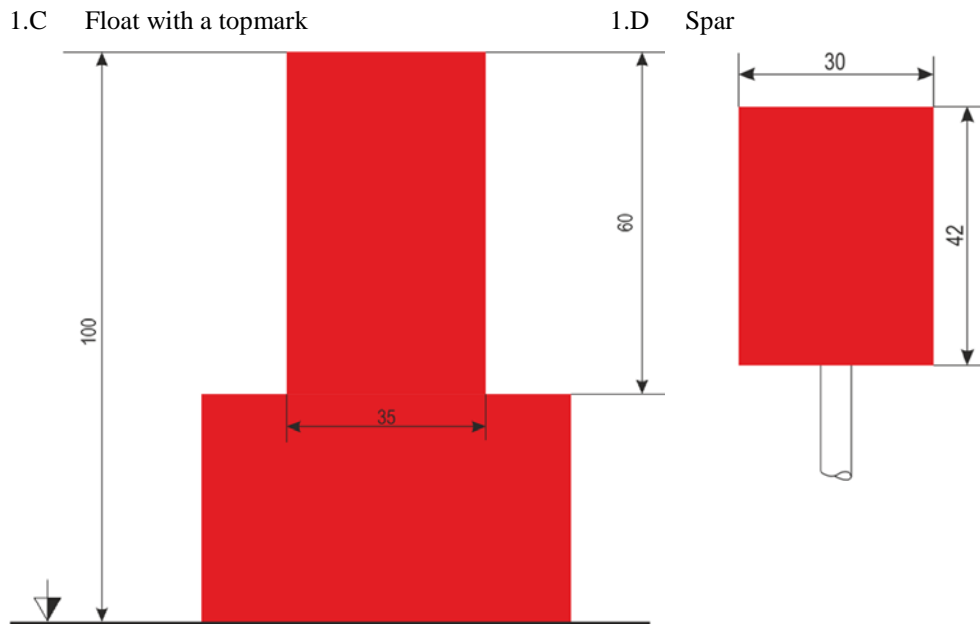

B. *Left-hand side of the waterway*

2.C Float with a topmark

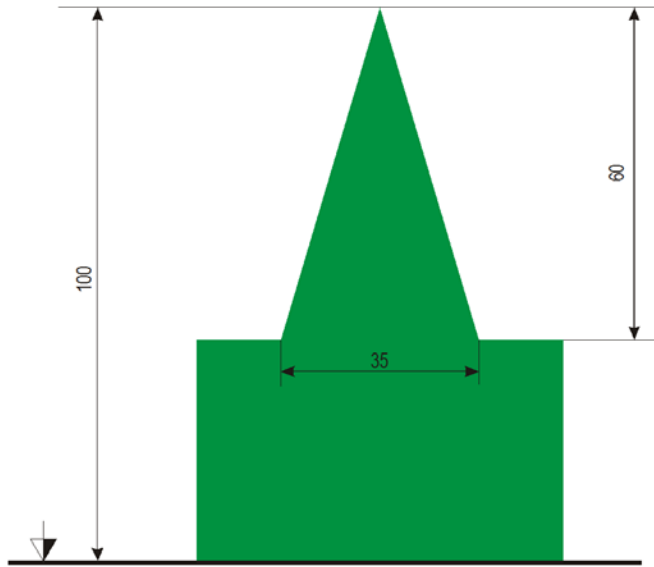

2.D Spar

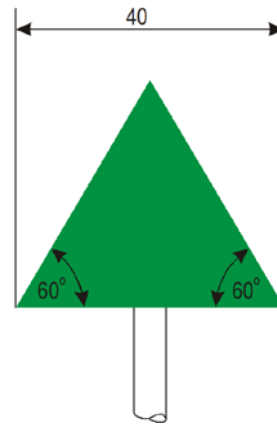

C. *Bifurcation of the waterway*

3.C Float with a topmark

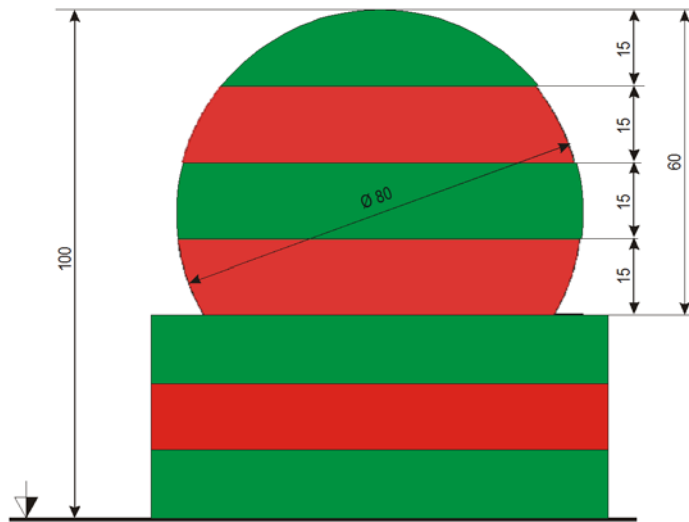

3.D Spar

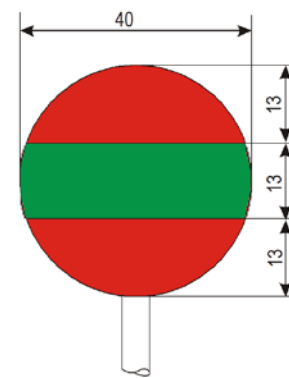

3.2 Bank marks indicating the position of the fairway

A. *Bank marks indicating the position of the fairway in relation to the banks*

(a) 4.B Channel near the right bank (without light)

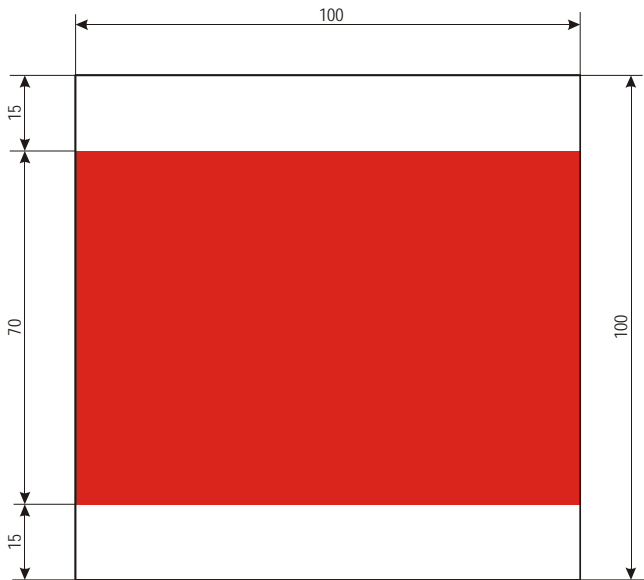

(b) 5.B Channel near the left bank (without light)

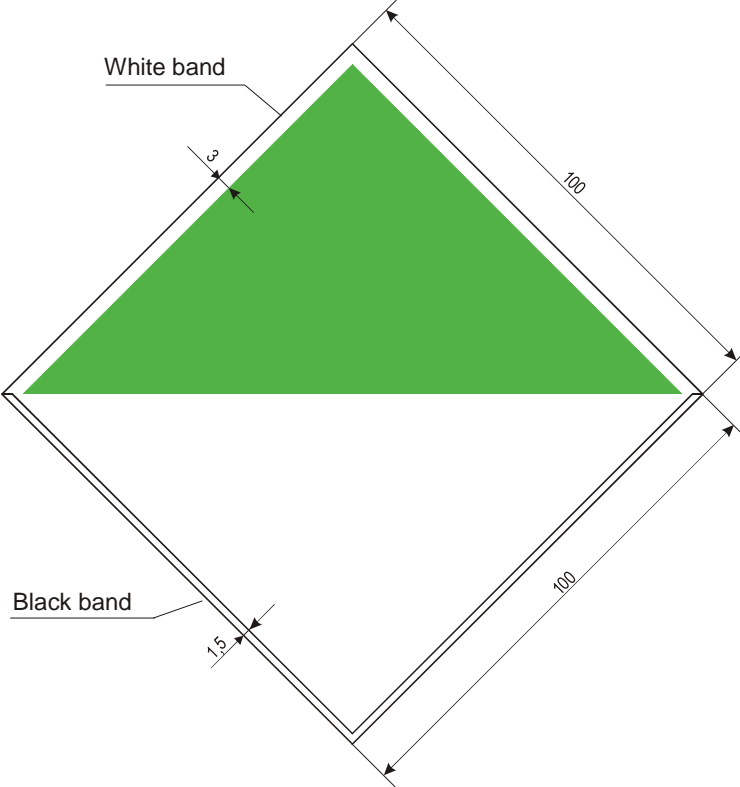

B. Cross-overs

(a) 4.D Right bank (without light)

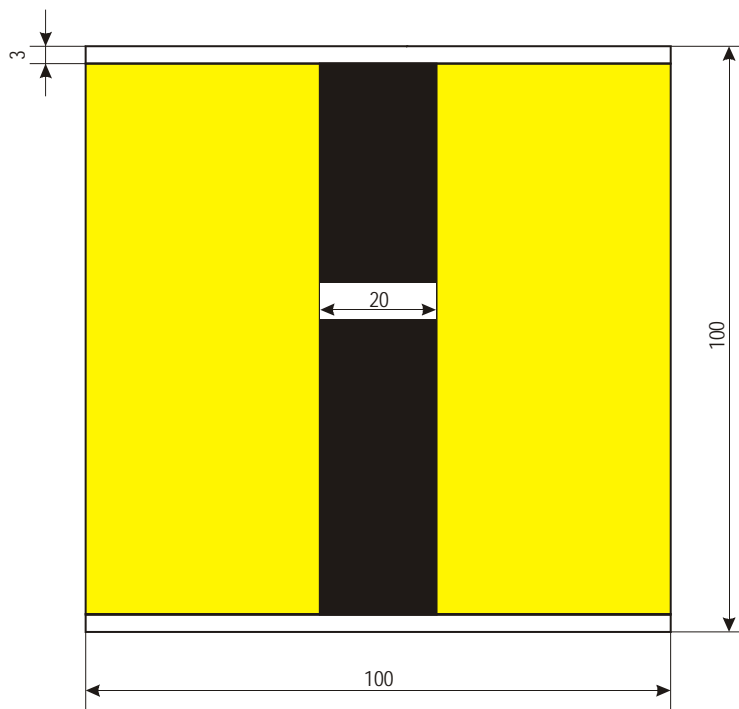

(b) 5.D Left bank (without light)

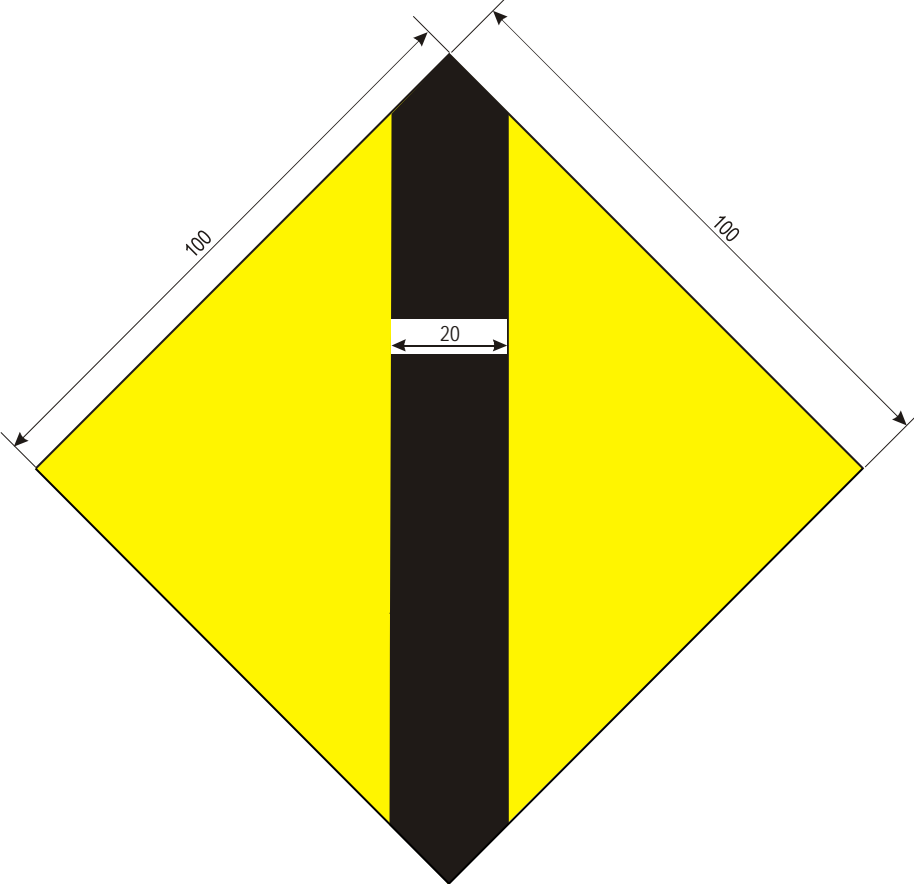

3.3 Buoyage and marking of danger points and obstacles

A. *Fixed marks*

(a) 4.F Right-hand side

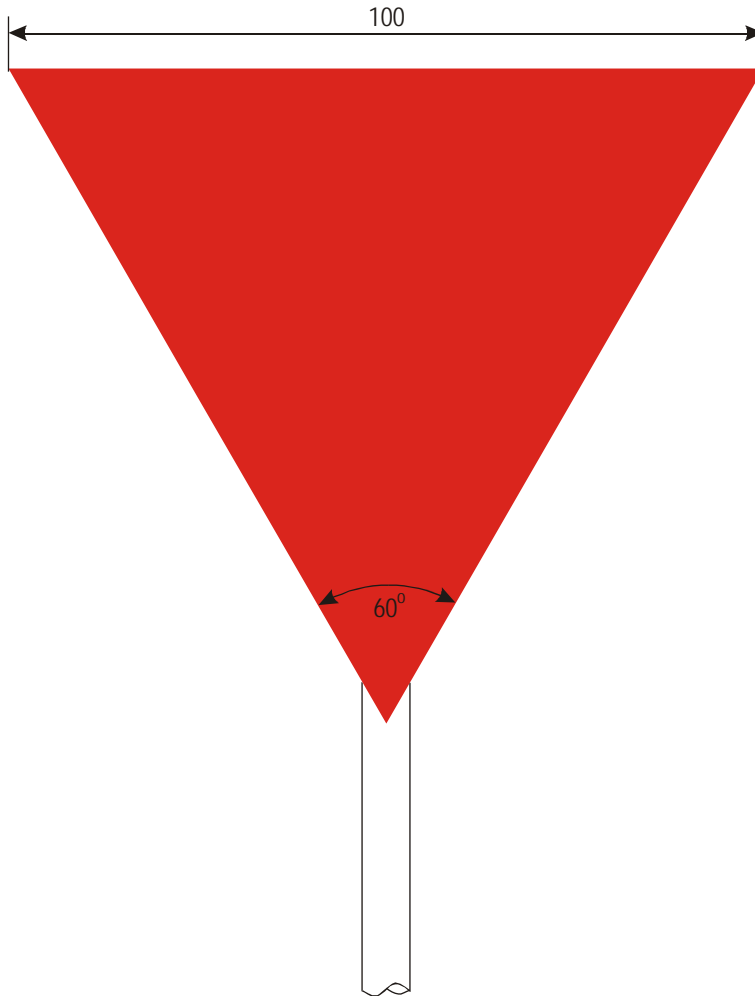

(b) 5.F Left-hand side

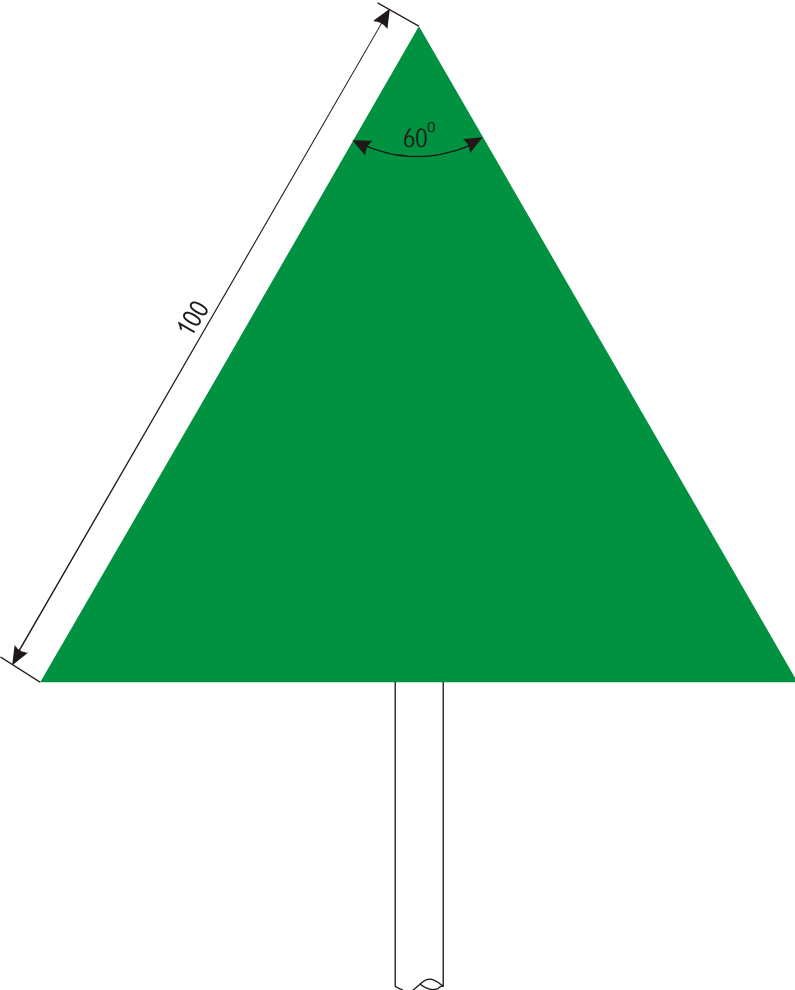

(c) 6.B Bifurcation

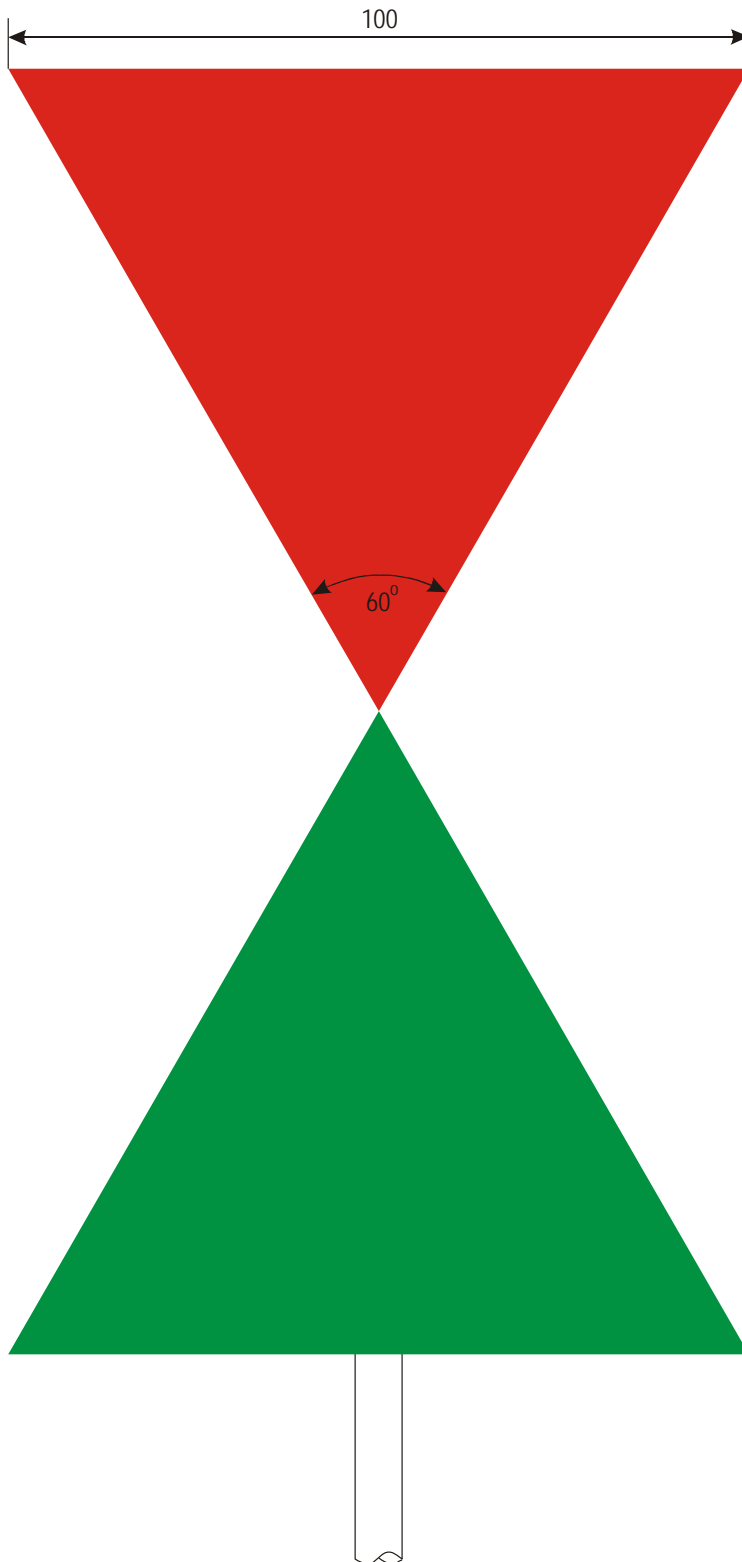

3.4 Radar reflectors on marking signs and signals and navigable passes through bridges

A. Radar reflectors on bridges

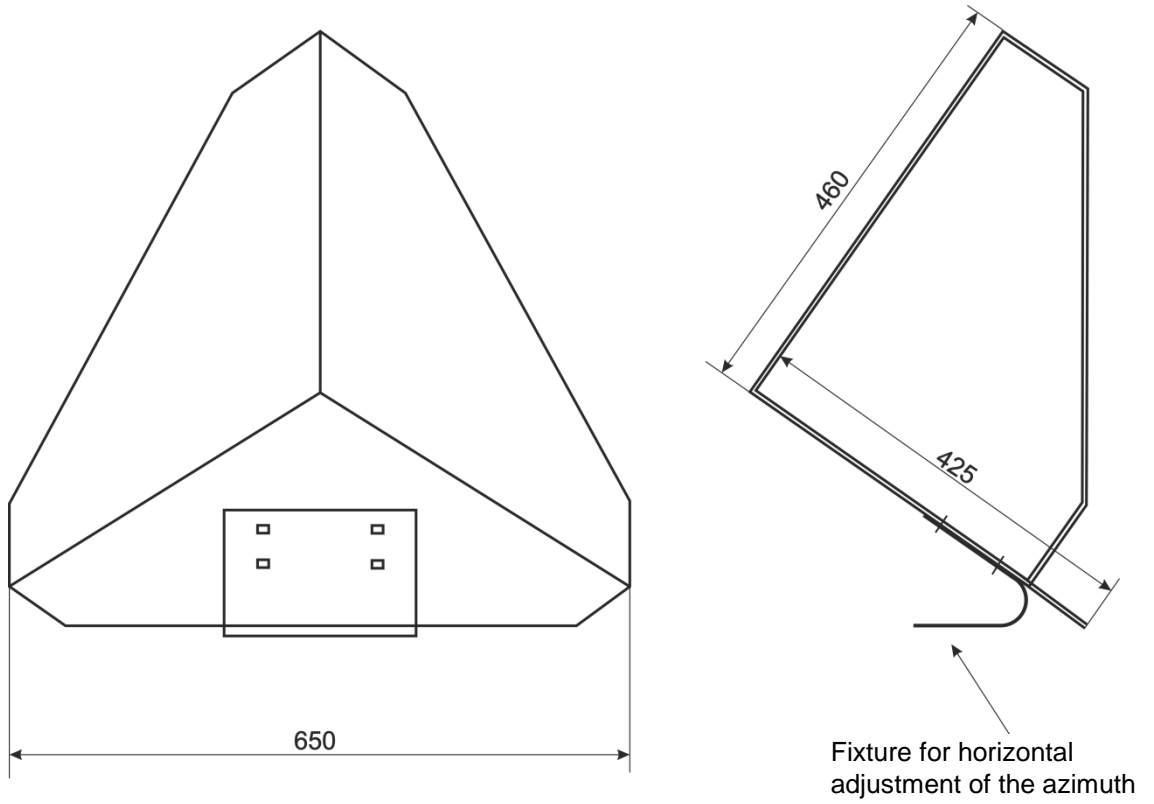

B. Radar reflectors on buoys and signs

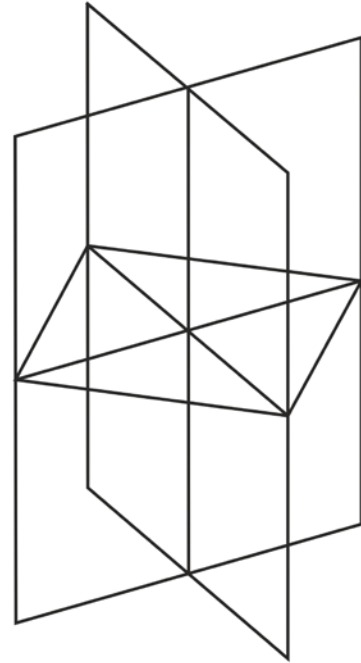
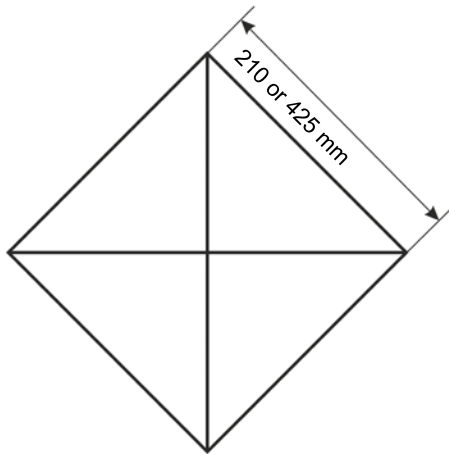
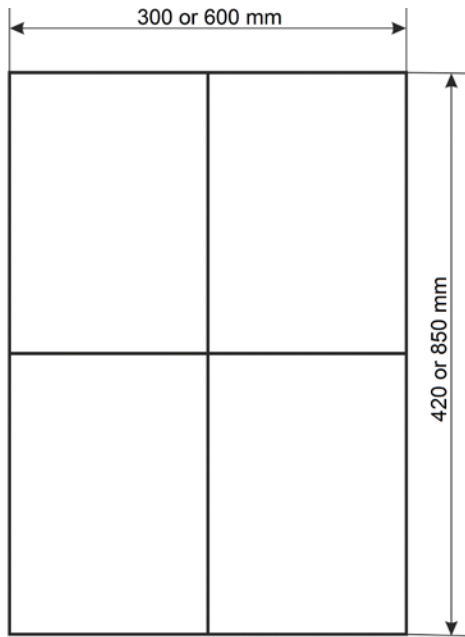

B. Appendix 2

Properties of lights

1. Categories of luminous intensity

Lanterns are classified according to their horizontally emitted photometric luminous intensity I_{ph} , in candelas (cd).

By analogy with luminous intensity for lights on board vessels, three distinct categories have been established, according to power.

Table 1

<i>Category</i>	<i>By analogy with light</i>	<i>Intensity of white light [cd]</i>	<i>Intensity of red/green/yellow light [cd]</i>
1	Ordinary	2-9	0.8-3.5
2	Bright	9-35	3.5-20
3	Strong	35-100	20-50

2. Acceptable colours of lights

The colours of lights are described in a standard chromatic diagram pursuant to ISO 11664/CIE S 014. The range of colours accepted in the standard chromatic diagram is determined according to standard CIE S 004/E-2001, Class A.

The chromatic coordinates for the acceptable ranges are as follows:

Table 2

<i>Colour</i>		<i>1</i>	<i>2</i>	<i>3</i>	<i>4</i>
White	<i>x</i>	0.300	0.440	0.440	0.300
	<i>y</i>	0.342	0.432	0.382	0.276
Yellow	<i>x</i>	0.536	0.547	0.613	0.593
	<i>y</i>	0.444	0.452	0.387	0.387
Red	<i>x</i>	0.660	0.680	0.690	0.710
	<i>y</i>	0.320	0.320	0.290	0.290
Green	<i>x</i>	0.009	0.284	0.209	0.028
	<i>y</i>	0.720	0.520	0.400	0.400

The yellow/red/green colour ranges are limited in addition by the curve of the colour spectrum. The ranges of colours are set out in figure 1.

Figure 1

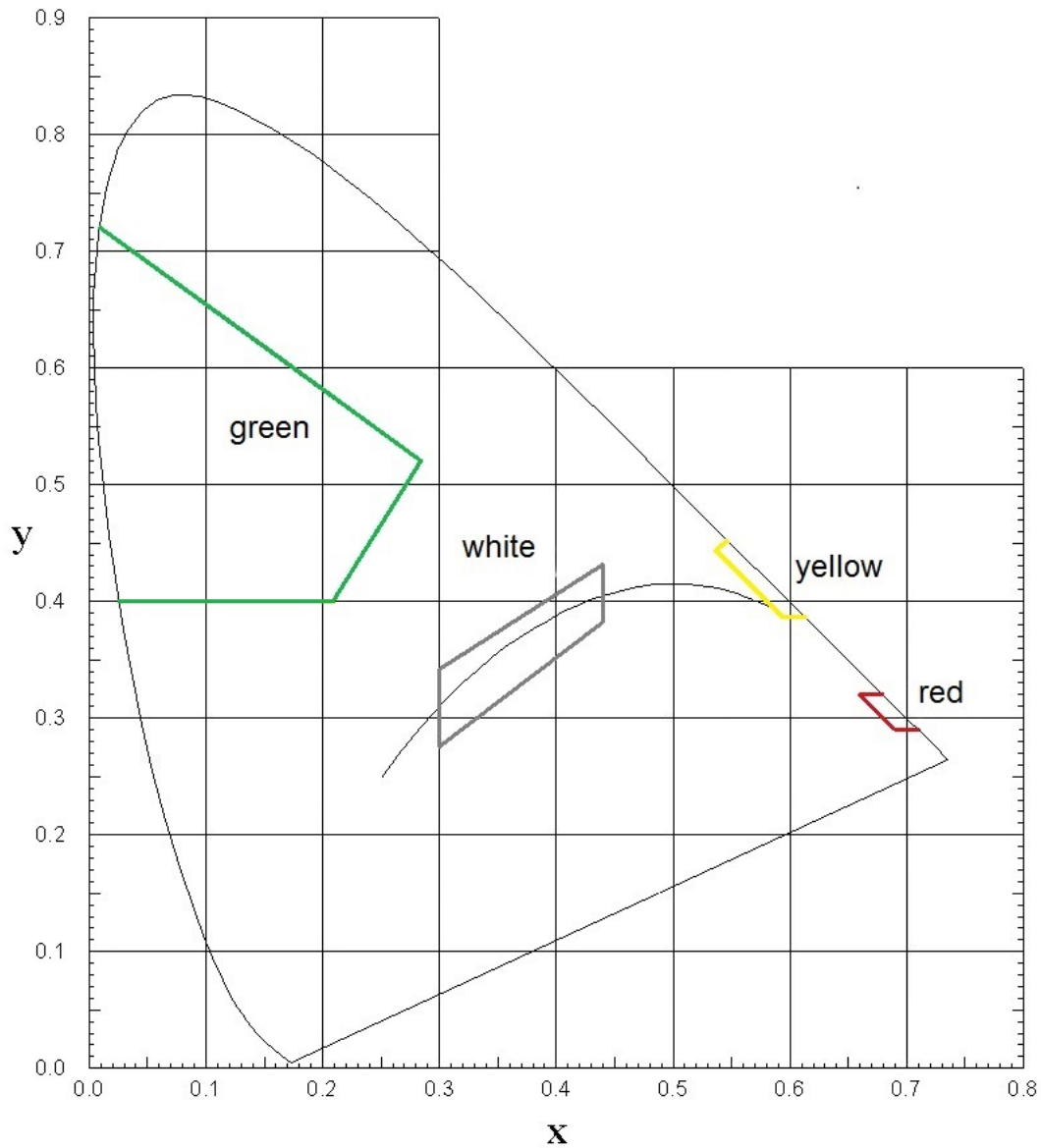

3. Calculation of light range

The range of a signal light intended for the guidance of shipping is calculated according to the procedure contained in IALA Recommendation E-200, Part 2 — Calculation, Definition and Notation of Luminous Range, which applies only to signal lights perceived as points by the observer.

Different criteria than those used to establish the range of on-board lights (navigation lights) have been developed for signals intended for the guidance of shipping, which use other values.

The calculations are performed using the following formula:

$$D^2 \times E_t = I_{\text{eff,B}} \times T_M^{\frac{D}{1852 \text{ m}}}$$

Where

D is the range of light;

$I_{\text{eff,B}}$ is the operational luminous intensity of the lantern;

T_M is the value for calculating visibility (describes the atmospheric transmissivity);

E_t is the established limit of luminosity.

The calculation must be done numerically; the formula cannot be solved according to D .

The parameters given are as follows:

$$T_M = 0.6;$$

$E_t = 2 \times 10^{-7}$ lx for buoys with lights and simple bank lights with no background lighting;

$E_t = 10^{-6}$ lx to mark a cross-fairway axis with 2 or 3 lights with no background lighting;

$E_t = 2 \times 10^{-6}$ lx for all lights with average background lighting (e.g. in a city);

$E_t = 2 \times 10^{-5}$ lx for all lights with substantial background light (e.g. industrial facilities).

The operational luminous intensity $I_{\text{eff,B}}$ is a derivative of the photometric values I_{ph} according to the following calculations:

$$I_{\text{eff,B}} = b \times k \times I_{\text{ph}}$$

Where $b = 0.75$ is the conventionally accepted loss factor owing to dirt and light source degradation.

The effective intensity of rhythmic lights is taken into account by the degree of transmission k , which is usually calculated according to IALA Recommendation E-200, Part 4 — Determination and Calculation of Effective Intensity.

For the light emitting diodes (LEDs) that are used in most cases and that permit very high frequency commutation, the calculations may be simplified to the following:

$$k = \frac{t}{0,2s + t}$$

Where t equals the shortest time of light for the rhythm of light used (e.g. 0.5 s for “Fkl. 1s” and 2 sec. for “Glt. 4s”).

Table 3

The typical range with visibility $T_M = 0.6$

<i>Background lighting</i>	<i>No</i>	<i>No</i>	<i>Average</i>	<i>Substantial</i>
<i>Light limit E_t [lx]</i>	2×10^{-7}	10^{-6} (marking of the axis)	2×10^{-6}	2×10^{-5}
<i>Luminous intensity $I_{\text{eff},B}$ [cd]</i>	<i>Range [m]</i>			
1	1 760	890	650	220
2	2 300	1 200	890	300
5	3 210	1 760	1 320	470
10	4 050	2 300	1 760	650
20	5 010	2 970	2 300	890
50	6 470	4 050	3 210	1 320
100	7 720	5 010	4 050	1 760
200	9 060	6 100	5 010	2 300
500	11 000	9 060	6 470	3 210

C. Appendix 3

Colours of reflected light for navigation signs

The colours of light reflected by navigation signs (day markings) must conform with CIE publication No. 39-2 (TC-1.6) 1983 “Recommendations for Surface Colours for Visual Signalling”.

The following is taken from the Recommendations:

Ordinary colours of materials (standard colours), in this case: red, yellow, green, blue, white and black;

Fluorescent colours of materials (luminescent in daylight), in this case: red, green.

The acceptable colours are given in ranges and with a standard chromaticity diagram, specifying as well the requirements for intensity coefficients (luminance factors). The chromaticity coordinates for the ranges and intensity coefficients are shown in Table 1. For colours adjacent to the spectral colour curve, the curve represents their external limit.

Table 1

<i>Colour of the reflected light</i>	<i>Intensity coefficient</i>	<i>1</i>		<i>2</i>		<i>3</i>		<i>4</i>	
		<i>x</i>	<i>y</i>	<i>x</i>	<i>y</i>	<i>x</i>	<i>y</i>	<i>x</i>	<i>y</i>
<i>Standard colours</i>									
Red	> 0.07	0.690	0.310	0.595	0.315	0.569	0.341	0.655	0.345
Yellow	> 0.45	0.522	0.477	0.470	0.440	0.427	0.483	0.465	0.534
Green	> 0.10	0.313	0.682	0.313	0.453	0.209	0.383	0.013	0.486
Blue	> 0.05	0.078	0.171	0.196	0.250	0.225	0.184	0.137	0.038
White	> 0.75	0.350	0.360	0.300	0.310	0.290	0.320	0.340	0.370
Black	< 0.03	0.385	0.355	0.300	0.270	0.260	0.310	0.345	0.395
<i>Colours luminescent in daylight</i>									
Red	> 0.25	0.690	0.310	0.595	0.315	0.569	0.341	0.655	0.345
Green	> 0.25	0.313	0.682	0.313	0.453	0.209	0.383	0.013	0.486

Figure 1 shows the admissible colour ranges on the standard chromaticity diagram. The ranges for ordinary colours and those that are luminescent in daylight (red/green) are identical; the colours differ only in their intensity coefficients.

Figure 1

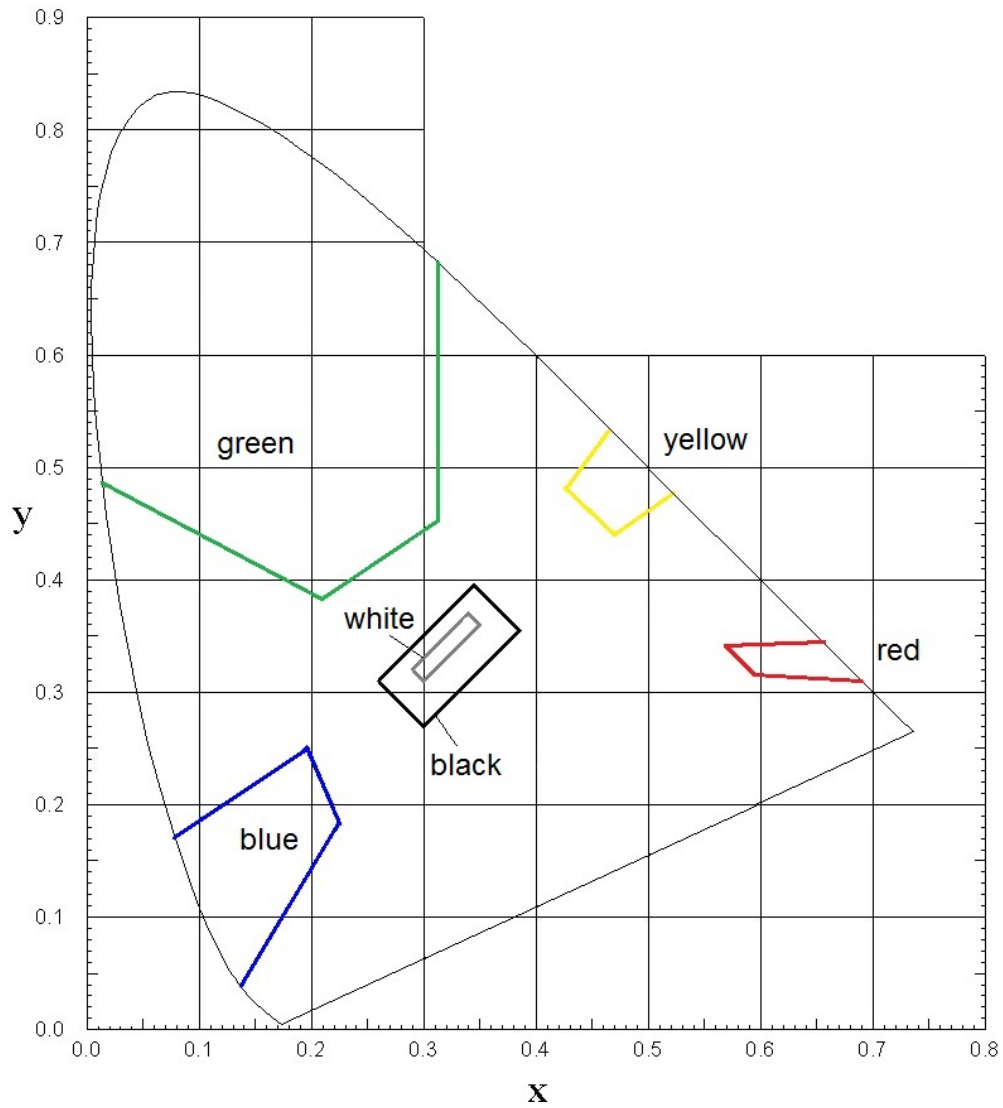

A simplified description of the admissible colours can be presented using the RAL numbers from the internationally recognized RAL-Classic colour system.³

The colours below correspond with the CIE Recommendations and are preferred for use in transport technologies.

³ www.ralcolor.com, www.ral-farben.de.

Table 2

<i>Number</i>	<i>Designation</i>	<i>Recommended use</i>
RAL 1023	Traffic yellow	Traffic signs, buoys
RAL 3020	Traffic red	Traffic signs
RAL 3024	Luminous red	Buoys, strongly visible traffic signs
RAL 3028	Pure red	Buoys, sufficiently visible traffic signs
RAL 5017	Traffic blue	Traffic signs
RAL 6024	Traffic green	Traffic signs
RAL 6037	Pure green	Buoys, sufficiently visible traffic signs
RAL 6038	Luminous green	Buoys, strongly visible traffic signs
RAL 9016	Traffic white	Traffic signs, buoys
RAL 9017	Traffic black	Traffic signs, buoys

It is recommended that navigation sign surfaces, when they are not a part of the signs themselves, should be RAL 7042 traffic grey A or RAL 7043 traffic grey B.

It may be advisable to use adhesive light-reflective films on markers that are not equipped with lights. For the colours of light-reflective films, reference may be made to the relevant international standards for road transport.

D. Appendix 4

Rhythmic lights

Table 1
Maximum periods of rhythmic characters of lights



<i>Class</i>	<i>Maximum period, s</i>
Isophase light	12
Single-occluding light	
Single-flashing light	15
Group very quick light	
Group-occluding light of two eclipses	
Long-flashing light	20
Group-flashing light of two flashes	
Group quick light	
Group-occluding light of three or more eclipses	
Group-flashing light of three or more flashes	30
Composite group-flashing light	
Morse Code light	



Note. The periods of rhythmic characters of lights should be selected in accordance with location-specific navigational requirements.



Table 2
Classification, specifications and application of rhythmic lights

Class	Abbreviation	General description	Specification	Particular use	
1	OCCULTING LIGHT	A light in which the total duration of light in a period is longer than the total duration of darkness and the intervals of darkness (eclipses) are usually of equal duration.	A light in which the total duration of light in a period is clearly longer than the total duration of darkness and all the eclipses are of equal duration.		
1.1	Single-occluding light	Oc	An occulting light in which an eclipse is regularly repeated.	The duration of an appearance of light should not be less than three times the duration of an eclipse. The period should not be less than 2 s.	A single-occluding white light indicates a safe-water mark. A single-occluding yellow light indicates a cross-over mark.
			 <p>Example: $l = 3 \text{ s}$; $d = 1 \text{ s}$; $p = 4 \text{ s}$</p>	$l \geq 3 d$ $p \geq 2 \text{ s}$	
1.2	Group-occluding light	Oc(#) e.g. Oc(2)	An occulting light in which a group of eclipses, specified in number, is regularly repeated.	The appearances of light between the eclipses in a group are of equal duration, and this duration is clearly shorter than the duration of the appearance of light between successive groups. The duration of an appearance of light between groups should not be less than three times the duration of an appearance of light within a group. The duration of an appearance of light within a group should not be less than the duration of an eclipse. In a group of two eclipses, the duration of an eclipse together with the duration of an appearance of light within the group should not be less than 1 s. In a group of three or more eclipses, the duration of an eclipse together with the duration of an appearance of light within the group should not be less than 2 s. The number of eclipses in a group should not be greater than four in general, and should be five only as an exception.	A group-occluding yellow light may indicate: - a special mark; - a cross-over mark.



Class	Abbreviation	General description	Specification	Particular use
			<p>Oc(2)</p> <p>Example: $l' = 6$ s; $l = 2$ s; $d = 1$ s; $c = 3$ s; $p = 10$ s</p>	$l' \geq 3 l$ $l \geq 3 d$ $c \geq 1$ s
1.3	Composite group-occluding light	Oc(#+#) e.g. Oc(2+1)	<p>A light similar to a group-occluding light except that successive groups in a period have different numbers of eclipses.</p> <p>Oc(2+1)</p> <p>Example: $l'' = 9$ s; $l' = 3$ s; $l = 1$ s; $d = 1$ s; $c = 2$ s; $p = 16$ s</p>	<p>This class of light character is not recommended because it is difficult to recognize.</p> $l'' \geq l'$ $l' \geq 3 l$ $l \geq d$ $c \geq 1$ s
2	ISOPHASE LIGHT	ISO	<p>A light in which all the durations of light and darkness are clearly equal.</p> <p>Example: $l = d = 2$ s; $p = 4$ s</p>	<p>The period should never be less than 2 s, but preferably it should not be less than 4 s in order to reduce the risk of confusion with occulting or flashing lights of similar periods.</p> $l = d$ $p \geq 2$ s
3	FLASHING LIGHT		<p>A light in which the total duration of light in a period is shorter than the total duration of darkness and the appearances of light (flashes) are usually of equal duration.</p>	<p>An isophase white light may indicate:</p> <ul style="list-style-type: none"> - a safe-water mark; - a bifurcation mark; - a mark outside the fairway indicating obstacles and danger points, if they can be passed on either side; - an advance signal. <p>A single-occluding white light indicates a safe-water mark.</p>
			<p>A light in which the total duration of light in a period is clearly shorter than the total duration of darkness and all the flashes are of equal duration.</p>	

<i>Class</i>	<i>Abbreviation</i>	<i>General description</i>	<i>Specification</i>	<i>Particular use</i>
3.1 Single-flashing light	FI	A flashing light in which a flash is regularly repeated (at a rate of less than 50 flashes per minute).	<p>The duration of the interval of darkness (eclipse) between two successive flashes should not be less than three times the duration of a flash.</p> <p>The period should not be less than 2 s (or not less than 2.5 s in those countries where a quick rate of 50 flashes per minute is used).</p>  <p>Example: $d = 3 \text{ s}$; $l = 1 \text{ s}$; $p = 4 \text{ s}$</p>	<p>A single-flashing red light may indicate:</p> <ul style="list-style-type: none"> - right-hand side of the fairway; - channel near the right bank. <p>A single-flashing green light may indicate:</p> <ul style="list-style-type: none"> • left-hand side of the fairway; • channel near the left bank. <p>A single-flashing yellow light may indicate:</p> <ul style="list-style-type: none"> - a special mark; - a cross-over mark.
3.2 Long-flashing light	LFI	A single-flashing light in which an appearance of light of not less than 2 s duration (long flash) is regularly repeated.	 <p>Example: $d = 8 \text{ s}$; $l = 2 \text{ s}$; $p = 10 \text{ s}$</p>	<p>$d \geq 3 l$</p> <p>$p \geq 2 \text{ s}$</p> <p>A long-flashing white light with a period of 10 s indicates a safe-water mark.</p>
3.3 Group-flashing light	FI(#) e.g. FI(2)	A flashing light in which a group of flashes, specified in number, is regularly repeated.	<p>The eclipses between the flashes in a group are of equal duration, and this duration is clearly shorter than the duration of the eclipse between successive groups.</p> <p>The duration of an eclipse between groups should not be less than three times the duration of an eclipse within a group.</p> <p>The duration of an eclipse within a group should not be less than the duration of a flash.</p> <p>In a group of two flashes, the duration of a flash together with the duration of the eclipse within the group should not be less than 1 s.</p>	<p>A group-flashing white light with a group of two flashes, in a period of 5 s or 10 s, indicates an isolated-danger mark.</p> <p>A group-flashing white light with a group of three flashes indicates a bifurcation mark.</p>



Class	Abbreviation	General description	Specification	Particular use
			<p>In a group of three or more flashes, the duration of a flash together with the duration of an eclipse within a group should not be less than 2 s (or not less than 2.5 s in those countries where a quick rate of 50 flashes per minute is used).</p> <p>The number of flashes in a group should not be greater than five in general, and should be six only as an exception.</p>	<p>A group-flashing yellow light with a group of four, five or (exceptionally) six flashes may indicate :</p> <ul style="list-style-type: none"> - a special mark; - a cross-over mark.
	FI(2)		 <p>Example: $d' = 6$ s; $d = 2$ s; $l = 1$ s; $c = 3$ s; $p = 10$ s</p>	$d' \geq 3d$ $d \geq 1$ $c \geq 1$ s
	FI(2)		 <p>Example: $d' = 6$ s; $d = 2$ s; $l = 1$ s; $c = 3$ s; $p = 10$ s</p>	$d' \geq 3d$ $d \geq 1$ $c \geq 1$ s
3.4	Composite group-flashing light	FI(# + #) e.g. FI(2 + 1)	<p>A flashing light in which a group of flashes, specified in number, is regularly repeated.</p> <p>Light characters should be restricted to (2+1) flashes in general, and should be (3+1) flashes only as an exception.</p>	<p>A composite group-flashing yellow light indicates a special mark.</p> <p>A composite group-flashing red or green light with a group of (2 + 1) flashes indicates a modified lateral (preferred-channel) mark.</p>
	FI(2+1)		 <p>Example: $d'' = 9$ s; $d' = 3$ s; $d = 1$ s; $l = 1$ s; $c = 2$ s; $p = 16$ s</p>	$d'' \geq d'$ $d' \geq 3d$ $d \geq 1$ $c \geq 1$ s

Class	Abbreviation	General description	Specification	Particular use
4	QUICK LIGHT	A light in which flashes are repeated at a rate of not less than 50 flashes per minute but less than 80 flashes* per minute.	A light in which identical flashes are repeated at the rate of 60 flashes per minute.	
4.1	Continuous quick light	Q	A quick light in which a flash is regularly repeated.  Example: $1 = d = 0.5 \text{ s}$; $p = 1 \text{ s}$	$d \geq 1$ $1 \text{ s} \leq p \leq 1.2 \text{ s}$ A continuous quick white light may indicate: - a north cardinal mark; - a bifurcation mark; - a mark outside the channel indicating obstacles and danger points, if they can be passed on either side.
4.2	Group quick light	Q(#) e.g. Q(3) e.g. Q(9) e.g. Q(6) + LFI	A quick light in which a specified group of flashes is regularly repeated. The number of flashes in a group should be three or nine. An exceptional light character is reserved to indicate a south cardinal mark.	A group quick white light with a group of three flashes, in a period of 10 s, indicates an east cardinal mark.
			Q(3)  Example: $d' = 7.5 \text{ s}$; $1 = d = 0.5 \text{ s}$; $c = 1 \text{ s}$; $p = 10 \text{ s}$	$d \geq 1$ $d' \geq d$ $1 \text{ s} \leq c \leq 1.2 \text{ s}$
			Q(9)  Example: $d' = 6.5 \text{ s}$; $1 = d = 0.5 \text{ s}$; $c = 1 \text{ s}$; $p = 15 \text{ s}$	$d \geq 1$ $d' \geq d$ $1 \text{ s} \leq c \leq 1.2 \text{ s}$ A group quick white light with a group of nine flashes, in a period of 15 s, indicates a west cardinal mark.

* The competent authorities should choose the rates for all their quick-lights and very quick lights: either 60 and 120 flashes per minute or 50 and 100 flashes per minute.

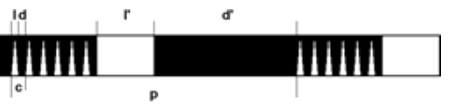
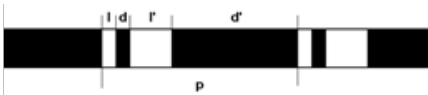
Class	Abbreviation	General description	Specification	Particular use
			<p>Q(6)+LFI</p>  <p>Example: $d' = 7$ s; $l' = 2$ s; $l = d = 0.5$ s; $c = 1$ s; $p = 15$ s</p>	<p>$d \geq 1$</p> <p>$l' \geq 2$ s</p> <p>$1 \text{ s} \leq c \leq 1.2 \text{ s}$</p> <p>A group-quick white light with a group of six flashes followed by a long flash of not less than 2 s duration, in a period of 15 s, indicates a south cardinal mark.</p>
5.	VERY QUICK LIGHT	A light in which flashes are repeated at a rate of not less than 80 flashes per minute but less than 160 flashes* per minute.	A light in which identical flashes are repeated at the rate of 120 flashes per minute.	
5.1	Continuous very quick light	VQ	<p>A very quick light in which a flash is regularly repeated.</p>  <p>Example: $l = d = 0.25$ s; $p = 0.5$ s</p>	<p>$d \geq 1$</p> <p>$0.5 \text{ s} \leq p \leq 1.6 \text{ s}$</p> <p>A continuous quick scintillating white light indicates a north cardinal mark.</p>
5.2	Group very quick light	VQ(#) e.g. VQ(3) e.g. VQ(9) e.g. VQ(6)+LFI	<p>The number of flashes in a group should be three or nine. An exceptional light character is reserved for use to indicate a south cardinal mark.</p> <p>VQ(3)</p>  <p>Example: $d' = 3.75$ s; $l = d = 0.25$ s; $c = 0.5$ s; $p = 5$ s</p>	<p>$d' > 1.5$ s</p> <p>$d \geq 1$</p> <p>$0.5 \text{ s} \leq c \leq 0.6 \text{ s}$</p> <p>A group very quick white light with a group of six flashes, in a period of 5 s, indicates an east cardinal mark.</p>

Class	Abbreviation	General description	Specification	Particular use
			<p>VQ(9)</p>  <p>Example: $d' = 5.75$ s; $l = d = 0.25$ s; $c = 0.5$ s; $p = 10$ s</p>	<p>$d' > 1.5$ s</p> <p>$d \geq 1$</p> <p>$0.5 \text{ s} \leq c \leq 0.6 \text{ s}$</p> <p>A group very quick white light with a group of nine flashes, in a period of 10 s, indicates a west cardinal mark.</p>
			<p>VQ(6)+LF1</p>  <p>Example: $d' = 5$ s; $l' = 2$ s; $l = d = 0.25$ s; $c = 0.5$ s; $p = 10$ s</p>	<p>$d' \geq 1.5$ l'</p> <p>$l' \geq 2$ s</p> <p>$d \geq 1$</p> <p>$0.5 \text{ s} \leq c \leq 0.6 \text{ s}$</p> <p>A group very quick white light with a group of six flashes followed by a long flash of not less than 2 s duration, in a period of 10 s, indicates a south cardinal mark.</p>
6	ULTRA QUICK LIGHT	A light in which flashes are repeated at a rate of not less than 160 flashes per minute and not more than 300 flashes per minute.	A light in which identical flashes are repeated at the rate of 240 flashes per minute.	
6.1	Continuous ultra quick light	UQ	An ultra quick light in which a flash is regularly repeated.	
7	MORSE CODE LIGHT	Mo(#) e.g. Mo(A)	A light in which appearances of light of two clearly different durations are grouped to represent a character or characters in the Morse Code.	Light characters should be restricted to a single letter in the Morse Code in general, and should be two letters only as an exception. The duration of a "dot" should be about 0.5 s, and the duration of a "dash" should not be less than three times the duration of a "dot".
			<p>Mo(A)</p>  <p>Example: $l' = 1.5$ s; $l = 0.5$ s; $d = 0.5$ s; $d' = 4.5$ s; $p = 7$ s</p>	<p>$l' \geq 3$ l</p> <p>$d \geq 1$</p> <p>$l = 0.5$ s</p> <p>A Morse Code white light with the single character "A" indicates a safe-water mark.</p> <p>A Morse Code yellow light, but not with either of the single characters "A" or "U", indicates a special mark.</p>

Class	Abbreviation	General description	Specification	Particular use
8	FIXED AND FLASHING LIGHT	F+ relevant character abbreviation, e.g. FFl, FIsO	<p>A light in which a low intensity fixed light phase is combined with a flashing phase of higher luminous intensity compliant with preceding classes of rhythmic characters in this table.</p> <p>Implementation of an FFl rhythmic character is shown below. Other combinations may be implemented as necessary.</p>  <p>Example: $d = 3\text{ s}$; $l = 1\text{ s}$; $p = 4\text{ s}$</p>	$d \geq 3\text{ l}$ $l \leq 1\text{ s}$
9	ALTERNATING LIGHT	Al## e.g. AlWR	<p>A light showing different colours alternately.</p> <p>This class of light character should be used with care, and efforts should be made to ensure that the different colours appear equally visible to an observer.</p>  <p>Example: $l = d = 2\text{ s}$; $p = 4\text{ s}$</p>	$l \cong d$ $l \leq 1\text{ s}$
10	OCCULTING ALTERNATING LIGHT	OcAl	<p>A light showing different colours alternately and a light in which the total duration of light in a period is longer than the total duration of darkness and the intervals of darkness (eclipses) are of equal duration.</p> <p>This class of light is particular to the use of New Danger Marking, and efforts should be made to ensure that the different colours appear equally visible to an observer.</p> <p>OcAlBY</p>  <p>$l = 1\text{ s}$; $d = 0.5\text{ s}$; $p = 3\text{ s}$</p>	<p>An occulting- alternating blue and yellow light indicates a New Danger mark.</p>

E. Appendix 5

Recommendations for the lighting of traffic signs⁴

1. General provisions

The lighting of signs shall be turned on only at night. During daytime, the sign must be identifiable with natural lighting.

The lighting may be arranged either with an external, backward-facing floodlight located in front of the sign or with lighting from the inside of translucent panels (internally backlit signs) as shown in figure 1.

Figure 1

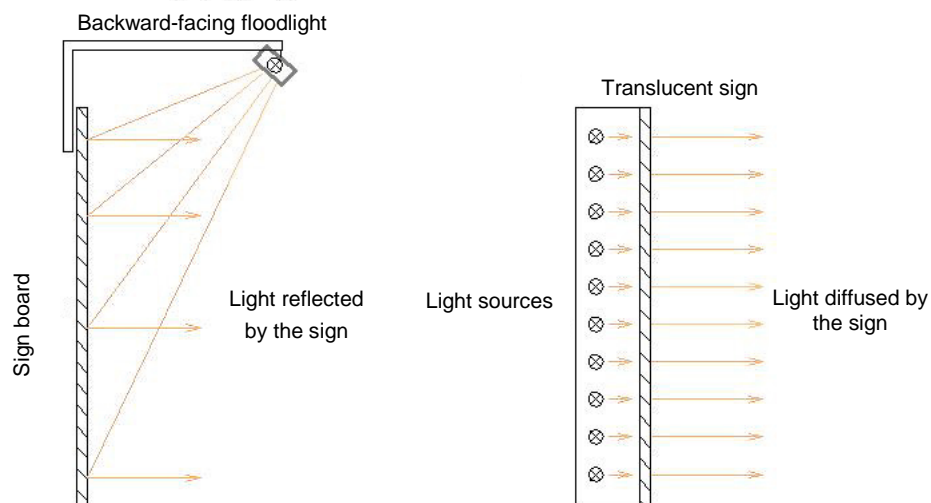

2. External backward-facing lighting of signs

External backward-facing lighting from a floodlight located above the sign is generally arranged with floodlights affixed above or below the sign board. For tall signs it is advisable to affix two floodlights (above and below). For wide signs it is possible to affix several floodlights in a line.

To avoid undesirable dark spots and glare, the floodlights must be located in such a way that they do not block a view from an angle of 7 degrees from the horizontal, drawn from the sign's top or bottom edge.

⁴ This appendix is based on the provisions of European standard EN 12899-1 "Fixed, vertical road traffic signs". Administrations can apply other international or national standards provided that the same safety level is ensured.

Figure 2

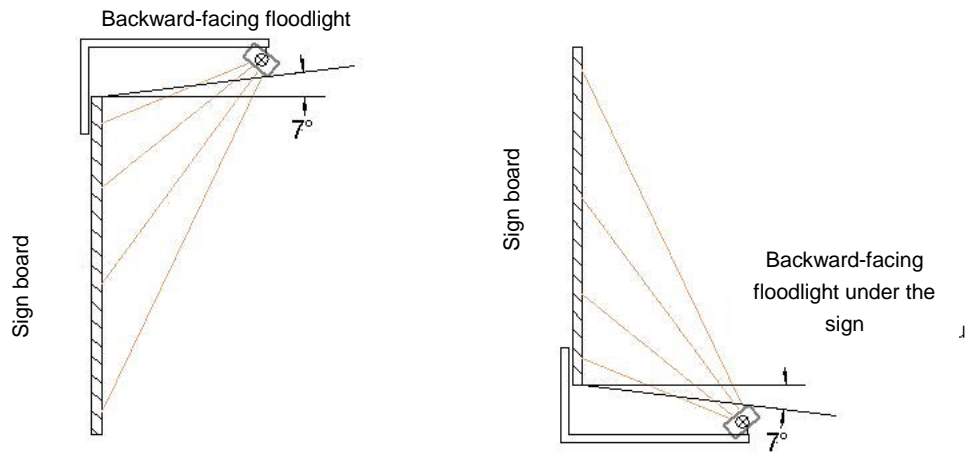

The type of lighting is always determined by the readability of the sign illuminated by the backward-facing light. Minimum dimensions of signs are given in appendix 1 to these Guidelines.

With some boards, the illuminated surface is identical to the board itself. If several boards conveying a single message are installed, for instance with additional text plates, the lighting requirements refer to the overall surface of the combined boards.

The recommended dimensions of the backward-illuminated surface of a sign board are shown in figure3:

- (a) a single board;
- (b) a board with an additional plate.

Figure 3

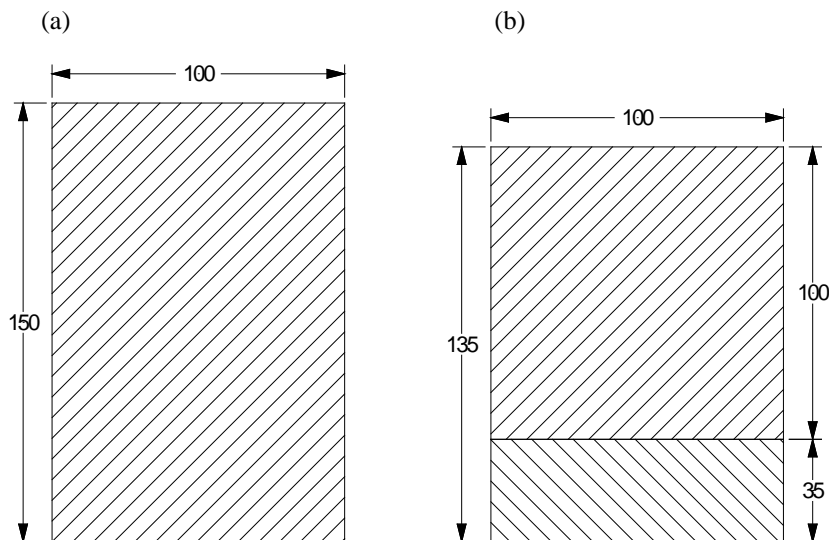

As for the backward-illuminated surface, the following lighting parameters are recommended:

in areas with insignificant background light levels (for example, outside of city limits), the luminosity measured on-site should range from 40 lx to 100 lx;⁵

in areas with increased background light levels (for example, within city limits), the luminosity measured on-site should range from 100 lx to 400 lx.⁶

The uniformity of lighting is established by the ratio between the minimum luminosity (E_{\min}) and the maximum luminosity (E_{\max}) on the back-illuminated surface. In all cases $E_{\min}:E_{\max} \geq 1:10$.⁷

For the lighting, a white lamp with a colour temperature between 3500 K and 4500 K is used. Care must be taken to ensure that the sign colours are reproduced when the backward-facing light is white.

3. Internally backlit signs

It is recommended to use intensity class L1⁸ for signs in areas with insignificant background light and intensity class L2 for those with increased background light levels.

As for the uniformity of the lighting, the aim should be to reach class U1 (1:10).

⁵ Class E1 of EN 12899.

⁶ Class E2 of EN 12899.

⁷ Class UE1 of EN 12899.

⁸ Intensity and uniformity classes in EN 12899.

F. Appendix 6

Examples of variable-message traffic signs⁹

1. Mechanical boards

A. Scrolling sign boards

Boards with a scrolled band of sign images are useful as variable message traffic signs, in particular for displaying the signs in annex 7 to CEVNI.

The sign images are placed on a band that is scrolled vertically on rollers. The rollers place the currently valid image in the window for display.

Figure 1

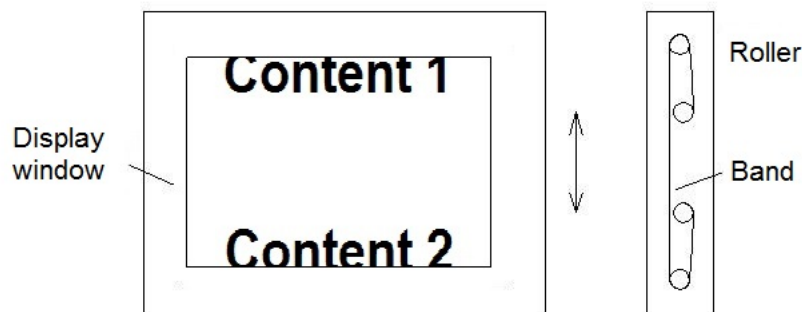

The advantage of scrolling sign boards is that they make it possible to display a large number of signs.

B. Trivision boards

Trivision boards are used preferably to display two different signs from annex 7 to CEVNI. This technique is limited to displaying three distinct sign images. Generally, the third position is reserved as blank, with a grey surface.

Figure 2

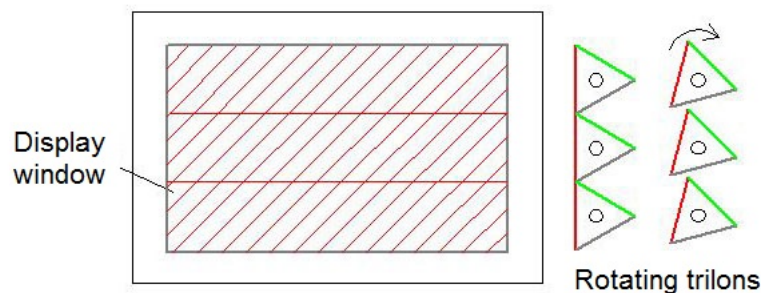

⁹ This appendix is based on the provisions of European standard EN 12966-1 “Vertical road signs — Variable message signs — Part 1: Product standard”. Administrations can apply other international or national standards provided that the same safety level is ensured.

In comparison with boards using scrolling bands, the advantage of trilons is that they are mechanically more robust. At the same time, it is not necessary to produce sign images on a flexible surface, which makes it possible to use paints and films of proven value for use on navigation signs.

C. Other mechanical boards

There are many mechanical systems for information boards (for example, including flip-disk boards), with many designed for use in indoor spaces (such as transport terminals or stations). For navigation signs, which generally have to bear the brunt of weather conditions, the service life of such systems is often negligible; they often require servicing.

2. Electronic boards

Purely electronic systems for information boards have the basic advantage of incorporating absolutely no moving parts. The ones that are best known are boards using LEDs, liquid crystals or optical fibres. Such messages are displayed as white or yellow digits or letters on a black background. During manufacture, the characters are converted into groups of constituent dots to ensure that they can be read.

While mechanical boards are visible with natural light during daylight hours, electronic boards emit light both day and night. At the same time, a contrasting frame is required, the aim being to reduce the so-called phantom effects caused by sunlight. Reflection angles must be sufficiently large to reliably eliminate reflections on the fairway segments in question. As a direct consequence, electronic boards consume significantly more energy than mechanical ones.

At the same time, in daylight, the boards must be sufficiently luminous so that their messages can be seen even in clear and sunny weather. At night, they must be darkened so as to avoid unwanted brightness or dazzle. Adjustments are made by measuring the background luminous intensity and adapting the intensity of the board accordingly.¹⁰

The boards' reflection angles should also be observed.¹¹

For horizontally illuminated sectors there are classes with ranges up to $\pm 30^\circ$ (60°). Technically, it is possible to display sectors ranging up to $\pm 60^\circ$ (120°) at an acceptable cost.

A. Optical waveguide (optical fibre) boards

Optical fibre boards have been used for many years on variable message road traffic signs (for example, to display temporary speed limits). The sign's image is divided into distinct points of light, with each point backlit by an optical fibre.

When a digit is displayed, the optical fibres of the digit in question are grouped and backlit with a lamp. For each digit there is thus a separate lamp, and each point of light can be used for just one digit. The points thus cannot be individually controlled. Each image must in turn have a source lamp.

¹⁰ If standard EN 12966-1 is used for this purpose, the adjustment coefficient (the board's maximum-to-minimum luminosity ratio) exceeding 100:1 is applied.

¹¹ The luminance classes described in standard EN 12966-1 are intended for road traffic and would presuppose that the boards are installed at least as high as the minimum height of a bridge allowing for navigation.

Figure 3

Depiction of light points corresponding with lamps for two digits (for clarity, only some of the optical fibres are shown)

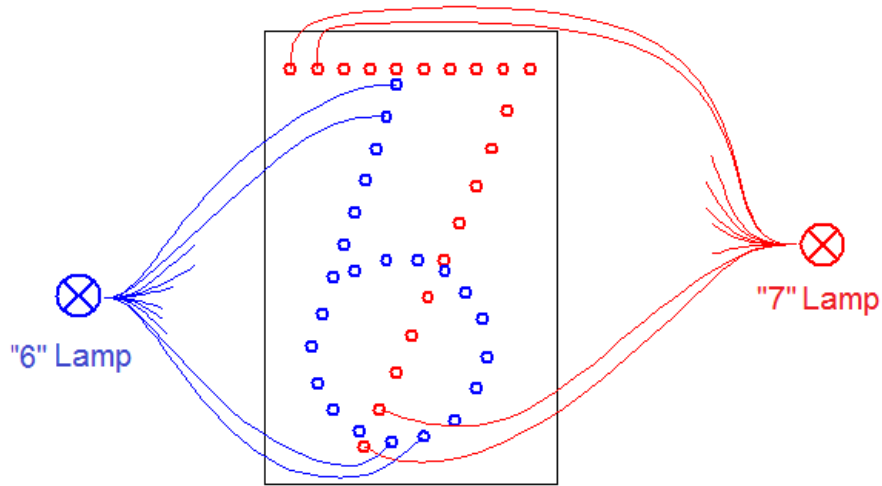

In recent years, optical fibre boards have to a great extent been replaced by LED matrix boards.

B. Light-emitting diode (LED) matrix boards

In the case of a LED matrix, each separate point of the image is displayed by a diode that can be independently turned on and off. In principle, such boards can be freely programmed (using a complete matrix), thus making it possible to display any message.

Figure 4

Board with individually controlled light emitting diodes displaying digits

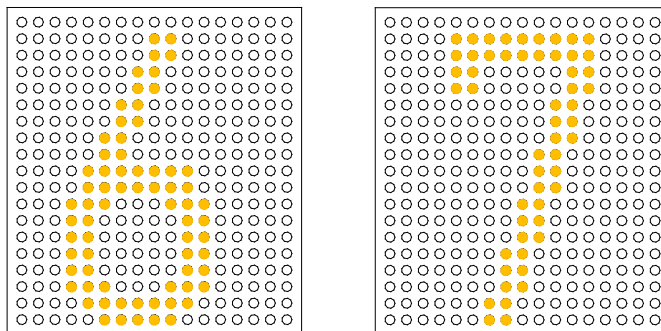

Often, though, only seven segments required to display digits are connected. As fewer diodes are used, the electronic control is simplified, which results in savings. To reduce costs, it is possible to pre-programme groups of LEDs to display only the messages that are required.

Figure 5
Board composed of seven segments with separate light emitting diodes

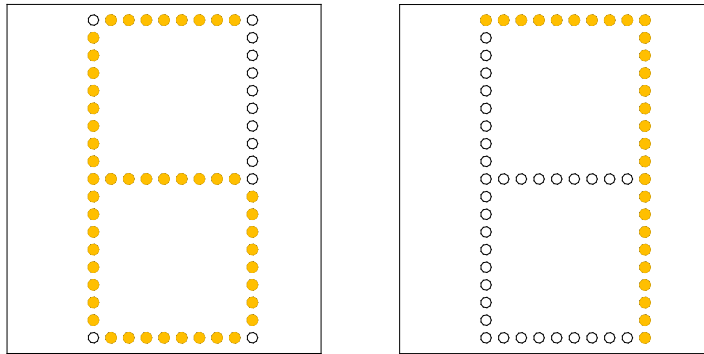

C. Liquid crystal displays (LCDs)

Boards using liquid crystal displays (LCDs) are composed of a regularly illuminated surface placed behind a film of liquid crystals, which blocks areas of the image, thus creating the desired figure. For large boards, monochrome images are preferred, although colour images are possible as well. Diodes have recently been employed to backlight the surface, while fluorescent lamps were previously used.

The advantage of this kind of board is that it produces a very sharp, detailed image, with such high luminosity and contrast that the boards can be used in daylight.

There is a technical disadvantage, though, as the optical characteristics of the liquid crystal film are such that only a small part (less than 25 per cent) of the generated light is displayed. For the same luminosity, boards of this kind require significantly more power than those using LED matrices.

In addition, liquid crystal displays shall be protected against temperature changes and humidity, which involves high costs.

