

# Impact Attenuating Devices to Protect Motorcyclists from Guardrail Posts

Informal document GRSP-65-35  
(65th GRSP, 13-17 May 2019,  
agenda item 28(a))



Federal Highway Research Institute (BAST)



# Post of Steel Guard Rail (Cross Section)



Bild 1: Einfache Schutzplanke mit Pfostenabstand 4,0 m (ESP/4,0)



Bild 2: Einfache Distanzschutzplanke mit Pfostenabstand 2,0 m (EDSP/2,0)

# What Can Happen to Motorcyclists?

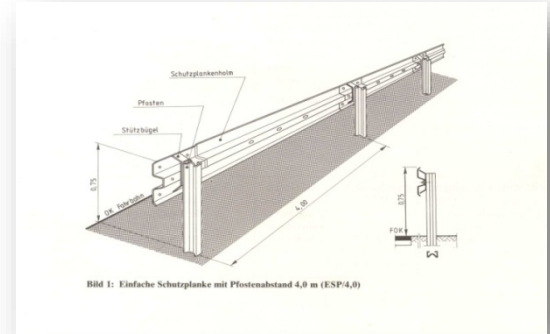
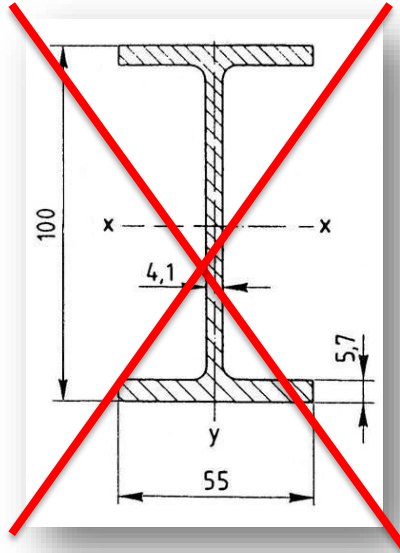
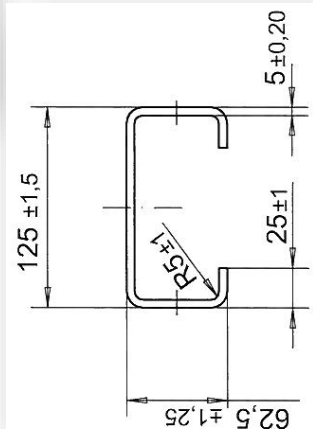
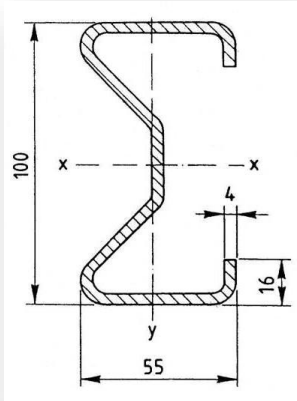

# What Can Happen to Motorcyclists?

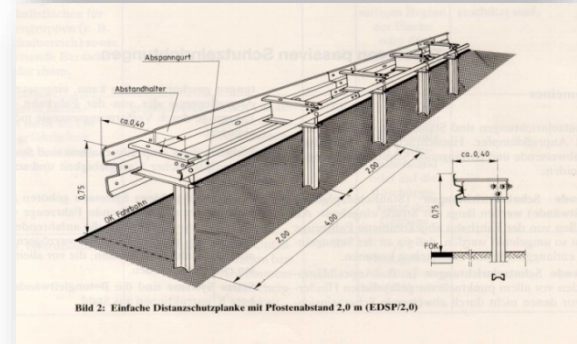

# Basics – Accident Data

In Germany we have about **26.000** accidents with injured motorcyclists per year.

**568** motorcyclists lose their lives each year.

In **1200** cases of all accidents with an injured motorcyclist a vehicle restraint system (VRS) was involved.



Picture: GIDAS

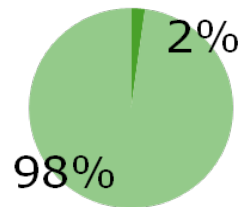

Only **2.2%** of all accidents of injured motorcyclists ends up in a fatality; but if VRS are involved the number increases to **14%**.

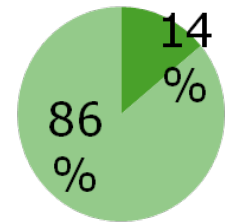

# Motorcyclist Protection Systems (MPS) in use

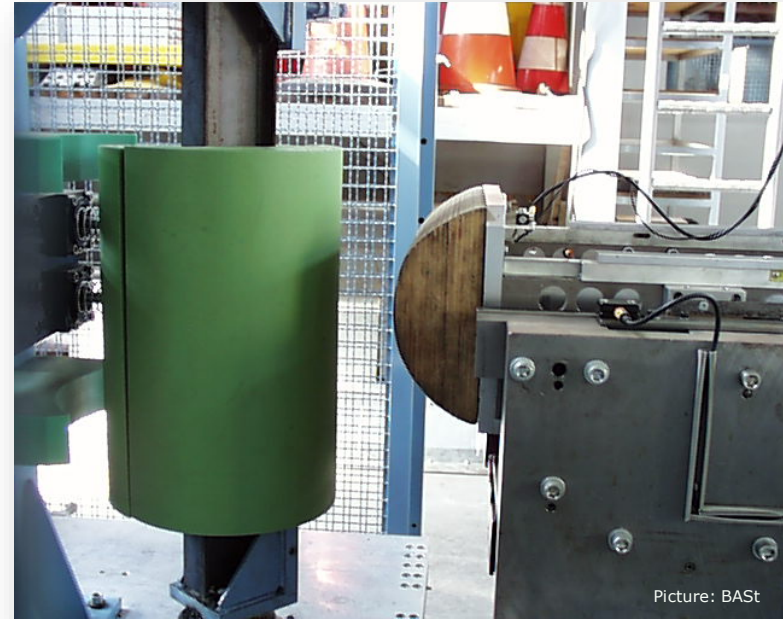
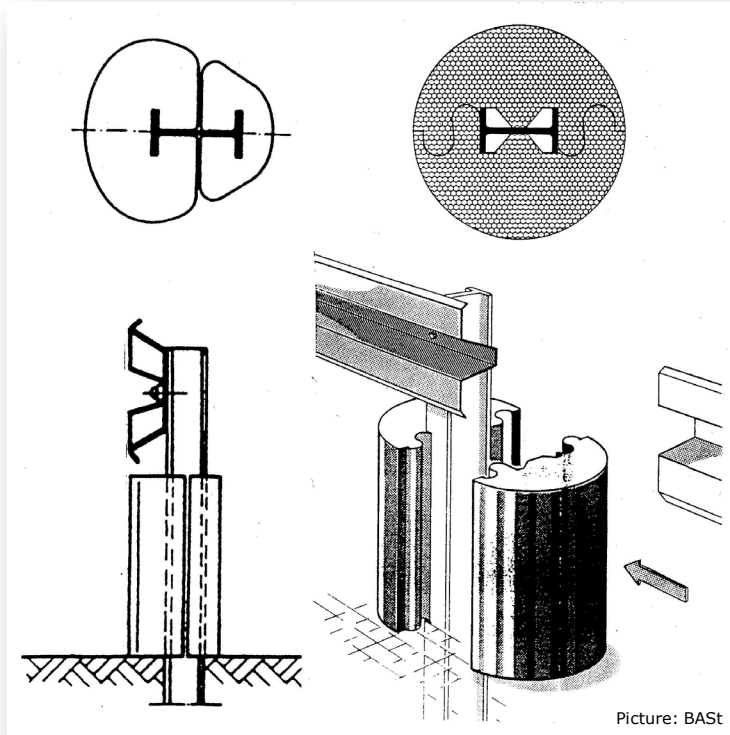

# Motorcyclist Protection Systems (MPS) in use

- Post Protection (SPU)
- ESP or EDSP with extra beam for underride protection
- Concrete Barrier

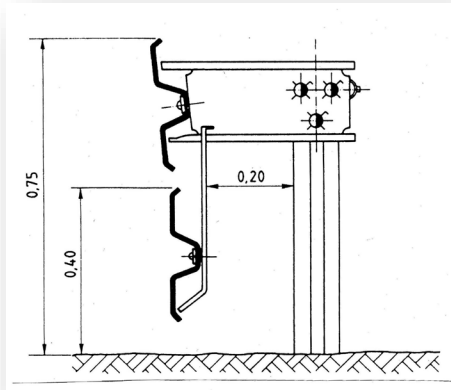

# Motorcyclist Protection Systems (MPS) in use

- Box beam with extra beam for underride protection





# Former Research

BAST started a research project to improve the situation.

The aim was the development of a system which is more „friendly“, e.g. less severe, for motorcyclists.



Pictures: DEKRA



## ➤ System Euskirchen Plus (ESP)

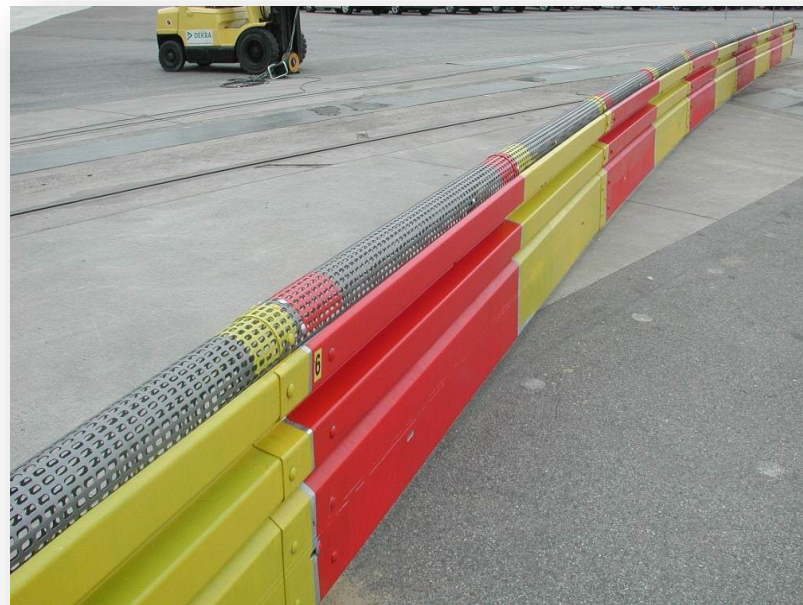
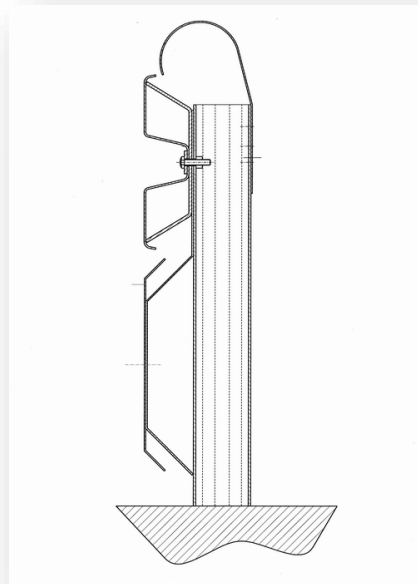

Pictures: BAST

## ➤ System Euskirchen Plus (ESP)





## ➤ System Euskirchen Plus (EDSP)



Pictures: BAST

# Additional Tests according to standard EN 1317

Containment	Level	Type	Velocity	Angel	Mass
Normal	N2	TB 32	110 km/h	20 °	1500 kg
		TB 11	100 km/h		900 kg



Pictures: BAST

# Current Research

- Identification of sharp elements of VRS



- Improving systems according to new standard EN 1317-8

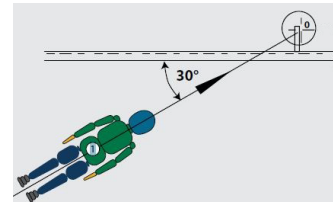

## Summary

- VRS need to be improved for motorcyclists!
- Protection for sliding and sitting impact

**Thank You  
for Your  
Attention!**



Picture: Menge, RP