

**Economic and Social Council**Distr.: General
23 March 2020

Original: English

Economic Commission for Europe

Inland Transport Committee

World Forum for Harmonization of Vehicle Regulations**Working Party on Pollution and Energy****Eighty-first session**

Geneva, 9-12 June 2020

Item 12 of the provisional agenda

Vehicles Interior Air Quality (VIAQ)**Proposal for an amendment to Mutual Resolution (M.R.3) of
the 1958 and the 1998 Agreements concerning Vehicle
Interior Air Quality (VIAQ)****Submitted by the Informal Working Group on Vehicles Interior Air
Quality (VIAQ)***

The text reproduced below was prepared by the Informal Working Group on Vehicles Interior Air Quality (VIAQ). The Informal Working Group on VIAQ presented a first draft of this proposal (GRPE-80-21) at the eightieth session of GRPE (see report ECE/TRANS/WP.29/GRPE/80, para. 67).

* In accordance with the programme of work of the Inland Transport Committee for 2020 as outlined in proposed programme budget for 2020 (A/74/6 (part V sect. 20) para 20.37), the World Forum will develop, harmonize and update UN Regulations in order to enhance the performance of vehicles. The present document is submitted in conformity with that mandate.

GE.20-04354(E)



* 2 0 0 4 3 5 4 *

Please recycle The recycling symbol, consisting of three chasing arrows forming a triangle.



Proposal for an amendment to Mutual Resolution (M.R.3) of the 1958 and the 1998 Agreements concerning Vehicle Interior Air Quality (VIAQ)

Contents

	<i>Page</i>
I. Statement of technical rationale and justification.....	4
A. Introduction	4
B. Procedural background	4
C. Existing regulations and standards.....	5
D. Technical rationale and justification	6
E. Technical feasibility, anticipated costs and benefits	9
II. Interior air emissions from interior materials	10
1. Purpose	10
2. Scope and application	10
3. Definitions	10
4. Abbreviations.....	11
5. General provisions	11
6. Normative references.....	12
7. Requirements for the test vehicle.....	12
8. Requirements for the test apparatus, instrument, and equipment	13
9. Test procedure, test mode, and test conditions	15
10. Calculation, presentation of results, precision and uncertainty	18
11. Performance characteristics	18
12. Quality assurance/quality control	18
III. Emission entering to the vehicle cabin with exhaust gases	20
1. Purpose	20
2. Scope and application	20
3. Definitions	20
4. Abbreviations.....	20
5. General provisions	20
6. Normative references.....	21
7. Requirements for the test vehicle.....	21
8. Requirements for the test apparatus, instrument, equipment and facility	21
9. Test procedure, test mode, and test conditions	23
10. Calculation, presentation of results, precision and uncertainty	25
11. Performance characteristics	25
12. Quality assurance/quality control	25
Annexes	
I Whole vehicle chamber.....	28
II Sampling position for measurement of emissions from interior materials	29

III	Test schedule	30
IV	Test report of interior air emissions measurement from interior materials	32
V	Idle test setup.....	38
VI	Test report of emissions entering to the vehicle cabin with exhaust gases.....	39

I. Statement of technical rationale and justification

A. Introduction

1. A variety of materials are being used for the construction of the interiors of vehicles. The materials used in the manufacturing of the vehicle include plastics, adhesives, cleaning products, plasticizers, paint, sealers, lubrication compounds, and many others.
2. Various kinds of chemical substances may be emitted from the interior materials inside the vehicle cabin. Some of the chemical substances may contain components, such as Volatile Organic Compounds (VOCs) including carbonyls like the aldehydes, some of them are not harmful to the human body, but some of them are known to cause various health issues. The amount of chemical substances emitted from interior materials may be particularly high, especially during the early stages of vehicle life.
3. Another source of harmful substances coming into the cabin include vehicle exhaust gases, fuel vapors, and the outside air pollution. Main components include substances such as CO, NO, NO₂, SO₂, volatile organic compounds (VOC) and particulate matter (PM).
4. Health effects vary depending on the individual driver and passenger's health and physical condition as well as exposure time and concentration of chemical substances. This Mutual Resolution supports the effort to ensure that levels of these chemical substances are measured under real exposure conditions.
5. Many countries throughout the world have already introduced standards concerning vehicle interior air quality. Several countries have established regulations or guidelines regarding emissions from interior materials, exhaust gases. Although these test procedures are very similar, there are many differences in test conditions.
6. This Mutual Resolution outlines the provisions and harmonized test procedure for the measurement of interior emissions, taking into account existing standards. It will encourage the reduced use of materials, and chemicals that can be harmful to humans, improving of cabin sealing and air ventilation system. It also encourages the increased use of emission-friendly materials, improving the air quality inside the passenger cabin.
7. Experts also have an interest in global harmonization since it offers more efficient development, adaptation to technical progress, and potential collaboration. It also facilitates the exchange of information between interested parties.
8. The regulatory stringency of legislation is expected to be different from region to region for the foreseeable future due to the different levels of development, different regional cultures, and the costs associated with interior emission control technology. Therefore, the setting of interior emission limit values is not part of this recommendation.

B. Procedural background

9. At their November 2014 sessions, the World Forum for Harmonization of Vehicle Regulations (WP.29) and the Executive Committee of the 1998 Agreement (AC.3) endorsed the proposed action plan to, in a first stage, collect information, review existing standards and develop recommendations. AC.3 noted the several aspects linked to VIAQ including safety matters (ECE/TRANS/WP.29/1112, para. 133).
10. The Informal Working Group (IWG) on VIAQ under the Working Party on Pollution and Energy (GRPE) reported the new recommendation of vehicle interior air quality that focuses on the interior air emissions generated from interior materials, in a first stage and on exhaust gases entering to a vehicle cabin in the second stage of work.
11. The Mutual Resolution (M.R.3) provides the provisions and harmonized test procedure for the measurement of interior air emissions, taking into account existing standards.

C. Existing regulations and standards

12. Many countries throughout the world have already introduced standards concerning vehicle interior air quality. Several countries have established regulations or guidelines regarding emissions from interior materials. Although these test procedures are very similar, there are many differences in test conditions.

13. Experts also have an interest in global harmonization since it offers more efficient development, adaptation to technical progress, and potential collaboration. It also facilitates the exchange of information between interested parties.

14. The VIAQ IWG conducted comprehensive studies of the existing individual contents regarding management of the interior air quality of vehicles. The bases of this harmonized set of recommendations are national standards from Republic of Korea, China, and the International Organization for Standardization (ISO), as well as Original Equipment Manufacturers (OEM) voluntary standards like Japan Automobile Manufacturers Association (JAMA) (JAMA Report No. 98).

15. Examples of existing regulations and standards:

(a) Republic of Korea

Automobile Management Act Article 33_3, 18 December 2012 "Interior air quality management for newly produced vehicles".

Ministry of Land, Infrastructure and Transport Announcement No. 2019_144, 27 March 2019 "The management standards of the interior air quality of new manufactured vehicles".

Korea established whole vehicle VIAQ requirements with the 2007 publication of "The management standards of the interior air quality of new manufactured vehicles". This notification outlines test procedures and emissions limits for specific VOCs, consideration of motor vehicle manufactures and sellers, and the release of VIAQ test results.

(b) China

HJ/T 400_07 December 2007 "Determination of Volatile Organic Compounds and Carbonyl Com-pounds in Cabins of Vehicles".

GB/T 27630-2011 01 March 2012 "Guideline for air quality assessment of Passenger car".

In China's standard, the Ministry of Environmental Protection and State Administration of Quality Supervision, Inspection and Quarantine, prescribed different concentration limits for eight VOCs, and is currently under revision to become a mandatory national standard.

(c) Russian Federation

GOST 33554-2015 "Motor vehicles –Pollutant content in the interior of driver's cab and passenger compartment. Technical requirements and test methods".

In the Russian Federation, test methods and regulations have focused on carbon monoxide, nitrogen oxides, formaldehyde, saturated hydrocarbons and methane emissions from vehicle exhaust gases that can enter the vehicle interior air during driving. The national standard GOST 33554-2015 was developed in 2015 to set limits for concentration of combustion products and certain hydrocarbons in vehicle interior air.

The expert from the Russian Federation stated that the work should not only focus on the interior air emissions generated from interior materials but also on the air pollutants entering the vehicle together with the intake air and through leakages from outside. GRPE considered the inclusion in the scope of

interior air pollutants from the outside air as a possible extension of the mandate at a later stage (ECE/TRANS/WP.29/GRPE/71).

(d) ISO Standards

ISO 12219-1:2012 "Interior air of road vehicles - Part 1: Whole vehicle test chamber – Specification and method for the determination of volatile organic compounds in cabin interiors".

The ISO Group TC22/TC146 SC6 JWG13 harmonized the vehicle interior air test method based on existing Korean, German Association of the Automotive Industry (VDA) and JAMA testing methods. The ISO 12219-1 testing method is adjusted VOC exposure in common user conditions: when sitting in a vehicle, ambient mode, when entering the vehicle after parking in the sun, parking mode and during driving, driving mode.

The JAMA voluntary standard was adopted to ISO 12219-1 standard in 2013.

D. Technical rationale and justification

16. This section introduces the main working items discussed and the technical rationale for developing a harmonized test procedure for the measurement of interior air emissions emitted from interior materials and entering to the cabin with exhaust gases.

17. The concentration of VOC in the vehicle cabin air can easily be different depending on temperature, humidity, pressure, sunlight, vehicle storage conditions, vehicle age, etc. The concentration of CO, NO, NO₂, CH₂O, PM and other harmful substances in the vehicle interior air depends on fuel type, design of exhaust system, vehicle tightness, ventilation and air conditioning system mode, vehicle speed, wind direction and velocity, etc. Therefore, it is important to standardize the test procedures to ensure valid results.

1. Vehicle category

18. Vehicle category was discussed very intensively. The review of existing standards showed differences. Some only covered small passenger vehicles, other even included buses and heavy-duty vehicles.

19. It was generally agreed to include passenger vehicles. However, light duty trucks, which are used as passenger vehicles should be included. It was furthermore agreed to exclude busses used for public transport and trucks used only for transport of goods. Vehicle category 1-1 of UNECE (1998 Agreement) TRANS/WP.29/1045 would be used as defined in the Special Resolution No. 1. Although Vehicle category 1-1 is primarily passenger vehicles, it can be extended to other vehicle categories in order to align with their domestic classification due to the different classifications of vehicle categories from region to region.

2. New vehicle

20. For the purpose of measurement of interior air emissions from interior materials the vehicle tested is intended to be a new vehicle from serial production. A new vehicle is directly transported from the production line to the testing lab. The test vehicle shall be driven less than 80 km of driving, i.e. less than 80 km on the vehicle odometer. Shipping the vehicle is allowed.

21. For the purpose of measurement of interior air emissions entering into the cabin with exhaust gases the vehicle tested is intended to be a new vehicle from serial production. The tested vehicle shall be run-in for at least 3000 km.

22. Used vehicles, prototypes, or developed test vehicles are not included, because these vehicles are likely to be constructed with materials and components not from serial production or contaminated during their use phase by non-original materials, users, and use conditions.

3. Vehicle test age for the measurement of emissions from interior materials

23. The ideal condition for the test vehicle would be to measure on the production date, since the amount of chemical substances is particularly high in the early stage of vehicle life. The material emission rate and interior concentrations of substances decrease over time. The sooner the measurement is taken, the higher the concentration results. However, it is very difficult for the customer, or laboratory person to get the new vehicle on the production date, the concentration rapidly decreases during that time, and it will cause a big deviation of test results.

24. The test age of a vehicle should be close to the age of the vehicle at hand over to the customer. Existing standards therefore define an average time of approximately one month. Variations can be high, to create reproducible results it was decided to adapt to existing definitions, taking 28 ± 5 days as the vehicle test age range.

4. Test vehicle mileage for the measurement of emissions entering into the cabin with exhaust gases

25. The test mileage of a vehicle should be in the range from 3000 to 15000 km to ensure running-in the engine and other vehicle components.

5. Test modes for the purpose of measurement of interior air emissions from interior materials

26. In order to get reproducible and comparable results it was decided to create a test method which is done in a highly defined environment. This can only be achieved inside a laboratory. Thus, real driving testing in varying outside conditions is not possible. Typical laboratory methods used today to measure interior air quality are Ambient, Parking and Driving modes.

27. Ambient mode simulates vehicles parked in the garage overnight using standard ambient conditions of 21°C to 27°C with no air exchange. There were different opinions on test temperature for ambient mode. The expert of Korea presented the test results between 23°C and 25°C , which showed no significant deviation between these temperatures. Test temperature of the ambient mode was set up " 23.0°C - 25.0°C as close as possible to 25.0°C " taking into account the technical point. It was shown that a soak time of 16 ± 1 h is sufficient to bring all vehicle parts to the temperature of the ambient mode. Shorter soak times would give deviation in measurement results, long soak times would lead to longer working hours and less test capacity in the laboratory and therefore higher costs.

28. Parking mode simulates vehicles parked outside in the sunlight at elevated temperatures using a fixed radiation heat. Heating the vehicle to a constant temperature would not consider the difference between well and badly insulated vehicles. Therefore, applying a constant solar load better represents a real parking situation. It was analysed that a solar load of 400 ± 50 W/m^2 reflects best a worldwide average. A soak time of 4 h has been shown to be sufficient to reach a constant interior air temperature. The emissions of Formaldehyde are measured in parking mode as a marker for emissions at elevated temperatures.

29. Driving mode simulates driving under a parked idling condition after the vehicle has been parked in the sun. The mode starts at an elevated temperature with climate control system on. The concentrations measured in the driving mode are close to the concentration customers are facing when driving in a vehicle. Of all test modes these concentrations are best suited to be taken for toxicological exposure evaluation.

5. Test modes for the purpose of measurement of interior air emissions entering into the cabin with exhaust gases

30. In order to measure emissions entering into the cabin with exhaust gases the tests should be conducted outside to reproduce real driving conditions in idle and constant speed modes.

31. Idle mode simulates a vehicle parked outside with its rear facing the wind direction. In this case it is possible that exhaust gases enter into the vehicle cabin through leakages of the vehicle body and through the ventilation system. The worst conditions were observed

when recirculation of air in the vehicle cabin is ON and the wind speed was in a range from 1 to 3 m/s.

32. Constant speed movement mode simulates real driving conditions in the city.

6. Substances to be measured

33. There are multiple substances emitted from the new vehicle interior materials. The most relevant substances based on the groups knowledge and the current standards were considered Formaldehyde, Acetaldehyde, Benzene, Toluene, Xylene, Ethylbenzene, Styrene, and Acrolein.

34. The most harmful substances, contained in exhaust gases which could enter into the vehicle cabin are Nitrogen monoxide, Nitrogen dioxide, and Carbon monoxide.

35. However, due to the different levels of development, different regional cultures, and the costs associated with interior air quality control technology, the regulatory stringency is expected to be different from region to region for the foreseeable future. The setting of interior emission concentration limit values, therefore, is not part of this recommendation for the time being. These substances limit values will be set by Contracting Parties depending on their situation.

7. Transportation and storage conditions for the purpose of emissions from interior materials

36. The VIAQ test is easily affected by test environment, such as transportation conditions, storage conditions, temperature, humidity, and cabin ventilation. In new vehicles, the concentration of substances is gradually decreased over time. Therefore, it is important to set the conditions to reduce the flexibilities in the test procedures. The vehicle has to be taken out of transportation mode and needs to be switched into customer mode prior to testing.

37. The base condition of the vehicle should be, closed doors and windows, and Heating, Ventilation and Air Conditioning (HVAC) system in recirculation mode to avoid contamination from outside pollutants. Therefore, test vehicles should be kept in the original status as close as possible. In addition, due to weather conditions, especially during the summer and winter, it will be recommended to keep exposure to sun limited and follow the normal production storage process.

38. Storage conditions in the plant or factory site before transportation are difficult to control. Therefore, storage conditions in the plant were not included in this test procedure, but should follow the normal production process.

39. For the purpose of emissions entering into the cabin with exhaust gases there are no special requirements.

8. Repeated measurements

40. To establish quality control, it is recommended to measure several vehicles and take multiple air samples of one vehicle for one result. It could be shown that vehicle measures according to this method do not differ much. Therefore, it was decided because of cost reasons that measuring one vehicle and taking just one sample of VOC and one sample of Aldehydes are sufficient for one result. However, general quality measures must not be neglected and should be periodically assessed.

9. Vehicle families

41. Out of cost perspective it is recommended to group vehicles with similar vehicle interiors in vehicle families and measure only the worst case vehicle. For the purpose of emissions from interior materials the vehicles with dark exterior and interior colour should have the highest heat impact and therefore the highest emissions. Furthermore, worst case vehicles should be equipped with highest amount of interior extras like sunroof, active seats, climate system, etc. Outside compartment parts like engines, tyres, batteries etc. will not have an impact on indoor air emissions and can be neglected in worst vehicle concepts. For the

purpose of emissions entering into the cabin with exhaust gases only serial equipment for air purification is allowed in the test cars.

E. Technical feasibility, anticipated costs and benefits

42. This Mutual Resolution has been developed by drawing on the experience of many stakeholders, including regulatory authorities, vehicle manufacturers and technical consultants. This Mutual Resolution has been designed to update and improve upon existing standards. The requirements are based on existing concepts in present standards in different contracting parties.

43. Since this Mutual Resolution is based on existing standards, Contracting Parties are invited to adopt the test procedure for the measurement of interior emissions. Particular test modes would be subject to optional acceptance by Contracting Parties depending on their situations. Therefore, no economic or technical feasibility study was deemed necessary. When transposing this VIAQ recommendation into national standards, Contracting Parties are invited to consider the economic feasibility of the VIAQ recommendation within the context of their own country.

44. This Mutual Resolution does not hold regulatory status within Contracting Parties. Contracting Parties and manufactures refer to the VIAQ recommendation when used for the assessment on vehicle interior air quality with the technical prescriptions of their own standards or regulations.

45. The principal economic benefit of the VIAQ recommendation will be a reduction in the variety of tests for the same, or substantially similar, test requirements.

46. Depending on how different Contracting Parties implement this Mutual Resolution, there may be benefits to facilitate the trade of VIAQ management, with harmonized test requirements among the respective Contracting Parties. Encouraging the use of environmentally-friendly materials and improvement of air ventilation and purification systems for the vehicle industry might be rationalized with the harmonized test requirements.

47. Safety benefits resulting from this Mutual Resolution depend on the permissible substance limit level in the national standards.

48. It is not possible to assess, at this moment, the total costs linked to this Mutual Resolution. However, the harmonization of the test procedure will reduce the global cost of VIAQ management in the countries which will apply the VIAQ recommendation through an administrative procedure.

49. Safety benefits are anticipated, but it is not yet possible to assess them in terms of the overall effect on human health.

II. Interior air emissions from interior materials

1. Purpose

The part II of the Mutual Resolution contains the provisions and harmonized test procedure for the measurement of interior air emission from interior materials, concerning the protection of passengers and driver from chemical emissions emitted from interior materials used for the construction of vehicles.

2. Scope and application

This Mutual Resolution applies to category 1-1 vehicle, as defined in the Special Resolution No. 1.¹

3. Definitions

For the purpose of this recommendation, the following definitions apply:

- 3.1. "*Test vehicle*" means the new vehicle to be tested. The test age of the vehicles has to be $28d \pm 5$ day after the production date;
- 3.2. "*Production date*" is the date a new vehicle leaves the production line;
- 3.3. "*Test substances*" means substances to be measured in air. Measured substances are Volatile Organic Compounds (VOCs) and the carbonyl compounds. VOCs range in volatility from n-C6 to n-C16 whose boiling point is in the range from (50 °C to 100 °C) to (240 °C to 260 °C). Carbonyl compounds include the aldehydes and ketones. In the test procedure the measured compounds are grouped by the term (VOC) and (carbonyl compounds) because each group currently requires two unique active sampling and analytical methods for measuring the test substances;
 - 3.3.1. "*Carbonyl compounds*" means Formaldehyde, Acetaldehyde and Acrolein. Carbonyl compounds are to be measured according to ISO 16000-3;
 - 3.3.2. "*VOCs*" means Volatile Organic Compounds ranging in volatility from n-C6 to n-C16, e.g. Benzene, Toluene, Xylene, Ethylbenzene and Styrene. VOCs are to be measured according to ISO 16000-6;
 - 3.3.3. "*Alternative VOC Measurement Method*" means a method that is proven equivalent to ISO 16000-3 or 16000-6. Two possible alternative methods could be an advancement to the current active sampling and desorption method 16000-6 or a direct sampling measurement method;
- 3.4. "*Background concentration*" means the test substance concentrations in the whole-vehicle test chamber when the test vehicle is inside;
- 3.5. "*Ambient mode*" refer to the mode in which sampling of substances in the interior air of a test vehicle under standardized ambient temperature conditions is performed, defined by 23.0-25.0 °C, as close as possible to 25.0°C;
- 3.6. "*Parking mode*" refer to the mode in which sampling of substances in the interior air of a test vehicle under elevated temperatures resulting from defined external heat radiation is performed;
- 3.7. "*Driving mode*" refer to the mode in which sampling of substances in the interior air of a test vehicle, under standardized conditions starting at elevated temperatures and with the engine on using air conditioning. Driving is

¹ ECE/TRANS/WP.29/1045, as amended by Amends. 1 and 2 (Special Resolution No. 1, www.unece.org/trans/main/wp29/wp29wgs/wp29gen/wp29resolutions.html)

simulated with an idle test procedure of a vehicle driven after being parked in the sun;

- 3.8. "*Breathing zone*" the semi-sphere area with 50 cm radius in front of the driver's face;
- 3.9. "*Sampling train*" means the apparatus to collect the air sample inside the test vehicle cabin from the breathing zone and to collect the air sample from in the whole vehicle test chamber, trapping the test substances in sorbent tubes under standardized conditions;
- 3.10. "*Category 1 vehicle*" means a power driven vehicle with four or more wheels designed and constructed primarily for the carriage of (a) person(s);
- 3.11. "*Category 1-1 vehicle*" means a category 1 vehicle comprising not more than eight seating positions in addition to the driver's seating position. A category 1-1 vehicle cannot have standing passengers.

4. Abbreviations

4.1. General abbreviations

VIAQ	Vehicle Interior Air Quality
GC-MS	Gas Chromatograph – Mass Spectrometry
HPLC	High Performance Liquid Chromatograph
DNPH	Dinitrophenylhydrazine
VOCs	Volatile Organic Compounds
HVAC	Heating, Ventilation and Air Conditioning

4.2. Chemical symbols and abbreviations

CH ₂ O	Formaldehyde [CAS#: 50-00-0]
C ₂ H ₄ O	Acetaldehyde [CAS#: 75-07-0]
C ₃ H ₄ O	Acrolein, Acrylic Aldehyde [CAS#: 107-02-8]
C ₆ H ₆	Benzene [CAS#: 71-43-2]
C ₈ H ₁₀	Ethyl benzene [CAS#: 100-41-4]
C ₈ H ₈	Styrene [CAS#: 100-42-5]
C ₇ H ₈	Toluene [CAS#: 108-88-3]
C ₈ H ₁₀	Xylene [CAS#: 1330-20-7]

5. General provisions

- 5.1. When instructed to include this test procedure in national standards, Contracting Parties are invited to adopt this Mutual Resolution for the measurement of interior air emissions from interior materials.
- 5.2. This Mutual Resolution does not hold regulatory status within Contracting Parties. Contracting Parties refer to the VIAQ recommendation when used for the assessment on vehicle interior air quality with the technical prescriptions of their own standards or regulations.
- 5.3. There are several test methods available for assessing vehicle interior air quality and this Mutual Resolution takes into account these existing standards. There are three test modes, each with their own testing method. These test modes would be subject to optional acceptance by Contracting Parties

depending on their situations. Contracting Parties may optionally decide to the test mode.

- 5.4. This Mutual Resolution will encourage the reduced use of materials, and chemicals that can be harmful to humans. It also encourages the increased use of environmentally-friendly materials, improving the environmental air quality inside the passenger cabin.
- 5.5. Substances to be measured are Formaldehyde, Acetaldehyde, Benzene, Toluene, Xylene, Ethylbenzene, Styrene, and Acrolein.
- 5.6. Due to the different levels of development, different regional cultures, and the costs associated with interior emission control technology, the regulatory stringency is expected to be different from region to region for the foreseeable future. The setting of interior emission limit values, therefore, is not part of this recommendation for the time being.

6. Normative references

- 6.1. ISO 16000-3, Indoor air — Part 3: Determination of formaldehyde and other carbonyl compounds in indoor air and test chamber air — Active sampling method.
- 6.2. ISO 16000-6:2011, Indoor air — Part 6: Determination of volatile organic compounds in indoor and test chamber air by active sampling on Tenax TA® sorbent, thermal desorption and gas chromatography using Mass Spectrometry (MS) or Mass Spectrometry–Flame Ionization Detector (MS-FID).

7. Requirements for the test vehicle

- 7.1. Test vehicles should only be new vehicles from serial production. Used vehicles are not included. The selection of vehicles should be based on a worst case interior to minimize testing cost. Vehicles with dark exterior and preferably black or dark interior colour are recommended for elevated temperature modes. Furthermore, grouping vehicles in families with similar interior emissions is also recommended. This approach can be based on summing up vehicles with the same interior line and similar interior volume.
- 7.2. The new vehicle, one not driven more than 80 km and within $28 \text{ d} \pm 5 \text{ d}$ after the sign-off date in the production line to be tested shall have been manufactured by the normal production process.
- 7.3. Transportation conditions from the assembly plant to the storing place and to the test facility
 - 7.3.1. Transportation of the vehicle should follow the normal transportation process.
 - 7.3.2. All windows and doors should remain closed. HVAC outlets should remain closed to avoid contamination.
 - 7.3.3. Ensure that no external off-gassing materials will be transported in the same cargo area. Minimize high solar load during all transportations. Documentation of all deviations from the normal transportation process in the test protocol shall be reported in the comments.
 - 7.3.4. Influence of the driver shall be as low as possible. The vehicle driver and handlers shall avoid the following: no smoking, eating, transportation of external items, and no perfume, inside or near the test vehicle.
 - 7.3.5. Protection covers used shall be the protection that will be used normally for transportation of the remaining production vehicles. Absorbers are only allowed if used in the normal transportation process.
- 7.4. Storing conditions for the vehicle

- 7.4.1. All windows, doors, and HVAC outlets keep closed to avoid from contamination and avoid direct sunlight.
- 7.4.2. Do not use any cleaning agent to remove any residues. Dust wiping, vacuuming, and cleaning with clear water is possible. Clear water cleaning form outside is possible.
- 7.4.3. No extra fuelling, only the first fuel at production shall be within the fuelling system.
- 7.4.4. Workers should carefully deal with the vehicle to prevent contamination.
- 7.4.5. Remove all protecting covers, foils, papers, stickers, absorbers, etc. at least 24 hours before measurement.
- 7.5. Storing conditions for the vehicle 24 hours before measurement
- 7.5.1. Storage shall be for 24 hours, of soak time before measurement nearby the test facility. Control the soak storage temperature as close as possible to room temperature between 20-30 °C.

8. Requirements for the test apparatus, instrument, and equipment

- 8.1. Whole vehicle test chamber
 - 8.1.1. The whole vehicle test chamber shall be large enough to accommodate the complete test vehicle and include a heating, cooling, humidity, ventilation, and filter system for the air and solar lights if necessary.
 - 8.1.2. The whole vehicle test chamber shall be capable of maintaining a temperature between 23.0 to 25.0 °C.
 - 8.1.3. Relative Humidity (RH) during the ambient mode in the whole vehicle test chamber should be 50 percent RH \pm 10 percent RH.
 - 8.1.4. Relative humidity during the ambient, parking, and driving modes in the whole vehicle test chamber shall be documented.
 - 8.1.5. The maximum background concentration for each test substance shall not exceed 20 $\mu\text{g}/\text{m}^3$ for each single component or a maximum of 10 percent of the respective target or limit value, whichever is less. If this is not met, the source of the contamination shall be identified and removed or covered to exclude it from the test result.
 - 8.1.6. The air exchange rate of the whole vehicle test chamber should be a minimum of twice per hour.
- 8.2. Heating radiator
 - 8.2.1. Infrared radiator, halogen radiator or other radiators to simulate sunlight. Wavelengths <300 nm shall be filtered out. The heating radiators used shall be powered to create a radiation density at the reference measurement point in the middle of the roof surface of the test vehicle of $400 \text{ W}/\text{m}^2 \pm 50 \text{ W}/\text{m}^2$ equal to $350 \text{ W}/\text{m}^2$ to $450 \text{ W}/\text{m}^2$.
 - 8.2.2. The heating area shall cover at least the area of the test vehicle cabin and an additional 0.5 m more on each side of the lower part of the glazing footprint, see Annex I. Position the heating radiators on the roof with a shining angle of 90° to the heating area. The shining angle can be slightly modified to correct to achieve uniformity of the solar load. There shall be no heating radiators shining from the side. The heating area shall be calibrated in squares of 25 cm \times 25 cm with a radiation density of $400 \text{ W}/\text{m}^2 \pm 50 \text{ W}/\text{m}^2$. The required radiation density shall be available directly after the lamps are switched on. This should be within a few minutes. The irradiation shall be measured in accordance with ISO 9060.

- 8.2.3. Take care not to have too short a distance between radiator and surface in order to avoid hot spots.
- 8.3. Sampling trains
- 8.3.1. Requirements for VOCs and carbonyl compounds sampling and measurement of the air in the cabin of the test vehicle and in the whole vehicle test chamber.
- 8.3.2. Sampling from inside the test vehicle shall have four sampling trains or a single sample inlet but split into four parallel sampling trains. Two for the VOC measurements in parallel and two for the carbonyl compound measurements in parallel in the test vehicle. The second method sample is an analytical backup only. One sampling line with a manifold for the division of the sampling flow outside the test vehicle is allowed. The sample train consists of the sampling line, heated if necessary, the sorbent tube and the DNPH cartridge for carbonyl compounds, the gas meters and the pumps.
- 8.3.3. Sampling in the whole vehicle test chamber. Four sampling trains are used to determine the background concentration of VOCs and carbonyl compounds in the whole vehicle test chamber. The sampling trains are identical to those of paragraph 8.3.2., apart from the sampling line, which is much shorter and not heated.
- 8.3.4. Prior to sampling, the sampling system shall be checked under the sampling load conditions for air-tightness. Do not skip this critical step because leaks have a high impact on the test results due to the large backpressure of the tubes and cartridges. To check for leaks plug the inlet to the sample system. Then use a vacuum pump to bring the sampling system to 21 inches of Hg vacuum then close a valve between the sample system and the pump. After 30 seconds, the sample system vacuum must be greater than 20 inches of Hg to proceed. If not, find and fix leak and repeat to proceed. Do not change the sample trains in any way after the leak check procedure is performed. Other equivalent leak checks can be employed.
- 8.3.5. Sampling lines are the tubing between the sampling points inside the test vehicle or via the manifold outside the test vehicle to the VOC sorbent tubes or DNPH cartridges respectively, see Annex I.
- 8.3.6. The sampling line shall be constructed as follows:
- (a) As short as possible (maximum 5 m) with an internal diameter of 4 mm or more;
 - (b) Of inert, non-emitting and non-absorbing/non-adsorbing material, e.g. stainless steel or polytetrafluoroethylene (PTFE) or glass;
 - (c) Proven that there are no contaminations or sink effects in the sampling line;
 - (d) With heating device, if necessary, to prevent condensation or deposition on the inner walls. Best practice is to control temperature to about 20 °C above air temperature inside the test vehicle.
- 8.3.7. The tubing should be inserted between the door and the door frame or between the door frame and the glazing and should be sufficiently non-compressible to ensure an unimpeded flow of air.
- 8.3.8. The chamber sampling line in the whole vehicle test chamber is placed near the test vehicle and goes to sorbent tubes or DNPH cartridges in parallel. The chamber sampling line is identical to that described in the preceding vehicle sample line but no heating is necessary. This second sampling line is needed to monitor the background concentration of the whole vehicle test chamber. This measurement is taken after the 24 hours temperature acclimation phase and just prior to opening the vehicle doors for the VOC conditioning phase.
- 8.4. Analytical equipment and materials

- 8.4.1. The analytical equipment used for the determination of VOCs and carbonyl compounds or formaldehyde alone shall be in accordance with ISO 16000-6 (VOCs) or ISO 16000-3 (carbonyl compounds), respectively. Alternative VOC Measurement Methods can be used if the method is proven equivalent to ISO 16000-3 or 16000-6.
- 8.4.2. It shall be proven for the VOC sorbent tubes and the DNPH cartridges that there is no breakthrough. This can be identified by a back-up sorbent tube that is analysed separately, specified in ISO 16017-1.
- 8.5. Blank measurements
- 8.5.1. Field blanks
- 8.5.1.1. The samples used as field blanks for VOCs and carbonyl compounds shall be from the same batch and treated in the same way as those used for sampling and analysis, including all devices and handlings, except that no gas is drawn through the sampling trains. Never remove the caps of the field blanks.
- 8.5.1.2. A field blank procedure shall be performed at least before each measurement series. A series is consecutive measurements of several vehicles.
- 8.5.1.3. The field blank shall not be deducted from the measured value.
- 8.5.1.4. All field blanks shall be reported with the corresponding measured values.
- 8.5.1.5. The requirements for analytical and GC-MS blanks are specified in ISO 16000-3 and ISO 16000-6.

9. Test procedure, test mode, and test conditions

- 9.1. The preparation procedure is divided into three parts:
- (a) Conditioning of the whole vehicle test chamber;
 - (b) Conditioning of the test vehicle;
 - (c) Performing sampling and analytical measurements.
- 9.2. Preparation and preconditioning of the whole vehicle test chamber, the vehicle, sample trains, and the field blanks.
- 9.2.1. Preparation
- (a) Connect the test apparatus with the test vehicle. Attach the cables and sampling lines to the door frame so that, when the doors are closed, there is a nearly airtight sealing. Furthermore, the sampling line for VOCs and carbonyl compounds sampling shall be installed in the test vehicle. The sample is positioned as specified in Annex I;
 - (b) Connect the sampling line with the manifold and the manifold with the sampling trains for VOCs and carbonyl compounds measurements outside the test vehicle;
 - (c) Connect the test apparatus within the whole vehicle test chamber;
 - (d) Install the heating radiators and the other installations listed in 6.1.
- 9.2.2. Preconditioning of the whole vehicle test chamber
- 9.2.2.1. Adjust the temperature of the whole vehicle test chamber to 23.0-25.0 °C, as close as possible to 25.0 °C during the ambient mode test. There may be the need for a heating or cooling device. The humidity should be 50 percent RH \pm 10 percent RH in the ambient mode.
- 9.2.2.2. The whole vehicle test chamber should be under good ventilation, and the air exchange rate should be twice per hour or higher. The interior materials of the whole vehicle test chamber shall have no appreciable emissions regarding the

- indoor air inside the test vehicle, see paragraph 8.3.8. about measuring the background concentration. The probe is positioned 1.0 m from the vehicle, see paragraph 9.4.1.1. for when and Annex I for where to take the measurement.
- 9.2.2.3. The heating of the interior of the cabin and the surfaces of the test vehicle is performed by solar load radiators from outside the test vehicle during the driving mode.
- 9.2.3. Preconditioning of the test vehicle
- 9.2.3.1. The essential conditions for the surroundings are as follows. The temperature during the ambient mode is adjusted to 23.0 to 25.0°C, as close as possible to 25.0 °C via the whole test chamber conditioning system. The preconditioning is started by opening the door for 30 to 60 minutes. After this, the door is closed for 16h ± 1h soak time, see Annex III.
- 9.2.4. Background Samples and Field blanks
- 9.2.4.1. Prepare the background samples and field blanks before the measurements are started, see paragraph 8.5. Install background sorbent tube samples for VOCs and one DNPH cartridge for carbonyl compounds in the sampling trains to measure the background concentration of the whole vehicle test chamber. The field blanks shall be handled in the same way as those used for VOC or carbonyl compound measurements, but without drawing air through the sampling trains. The field blanks samples shall remain sealed and retained for analysis with the interior air samples.
- 9.2.4.2. Perform at least one field blank set for each measurement series. Analytical GC–MS or HPLC blanks shall be performed according to paragraph 8.5.
- 9.3. Overview of test mode conditions
- 9.3.1. Ambient mode
- Vehicle ambient mode is at the specified temperature, 23.0 to 25.0 °C, as close as possible to 25.0 °C for 16 ± 1 h, for example overnight. At the end of the soak period, the sampling of VOCs and carbonyl compounds in the interior air is to be performed.
- 9.3.2. Parking mode
- Vehicle parking period is at the specified solar load for 4 hours at the end of which the sampling of carbonyl compounds in the interior air is to be performed.
- 9.3.3. Driving mode
- This test mode that simulates the operation of the test vehicle after it is parking at elevated temperature within 30 min during which the sampling of VOCs and carbonyl compounds in the interior air is to be performed.
- 9.4. Test procedure
- Store vehicle at 20 to 30 °C for 24 hours before start.
- 9.4.1. Ambient mode
- 9.4.1.1. After the conditions of the whole test chamber have been controlled to 23.0-25.0 °C, as close as possible to 25.0 °C and 50 percent RH ± 10 percent RH and the air exchange rate in the test chamber has been adjusted to a recommended value of at least twice per hour, the test procedure is started. At this time, turn on the four sampling trains in the whole vehicle test chamber to determine the VOCs and carbonyl compounds background concentrations, two thermal desorption sampling trains for VOCs and two DNPH cartridge sampling trains for carbonyl compounds. The probe is positioned 1.0 m from the vehicle, see Annex I. The relative humidity and the temperature are measured in the same position. After the chamber sample is finished start the conditioning of the test vehicle by opening all doors for 30 to 60 minutes.

- Install the sampling train including the two VOC sorbent tubes and the two DNPH cartridges, and leak-check the sampling train. An overview of the number of samples to be taken is given in Annex III.
- 9.4.1.2. Continue by conditioning the whole-vehicle test chamber and close all doors of the test vehicle for $16 \text{ h} \pm 1 \text{ h}$, e.g. overnight, at 23.0 to 25.0 °C, as close as possible to 25.0 °C and 50 percent RH ± 10 percent RH and keep the air exchange rate in the whole vehicle test chamber at a minimum of twice per hour, this is a recommended value. There is no dynamic ventilation of the test vehicle.
- 9.4.1.3. Before the sampling starts, purge the dead volume of the sampling line. Turn on the pumps of the four sampling trains, two for VOCs and two for carbonyl compounds, each in parallel. Perform the sampling of air samples in the test vehicle cabin in the ambient mode at room temperature, 23.0 to 25.0 °C, as close as possible to 25.0 °C, for 30 min. Adjust the flow rate to maximum 0.2 l/min for VOCs and 1.0 l/min for carbonyl compound measurements. The measurement procedures specified in ISO 16000-6 and ISO 16000-3 shall be followed.
- 9.4.1.4. Turn off the pumps for the VOCs and carbonyl compounds sampling, read and register the measurement volumes and take the VOC sorbent tubes and DNPH cartridges, which are placed outside the vehicle cabin, out of the sampling train. Seal the sorbent tubes or cartridges and analyse according to ISO 16000-6 and ISO 16000-3.
- 9.4.2. Parking mode
- 9.4.2.1. Start the parking mode with the heating-up procedure. The following tasks shall be performed. Start heating with the heating radiators, see paragraph 8.2. The irradiation is adjusted to $400 \text{ W/m}^2 \pm 50 \text{ W/m}^2$ and maintained at that level for 4.5 hours, see Annex III. Adjust the air exchange rate to twice per hour or higher; this is a recommended value for the whole vehicle test chamber.
- 9.4.2.2. Install the two DNPH cartridges in the two sampling trains for the test vehicle measurement and two for the whole vehicle test chamber. Before the sampling begins, check the sampling train for leaks, see paragraph 8.3.3. and purge the dead volume. Turn the pumps of the four sampling trains on. Perform formaldehyde sampling in the test vehicle cabin at elevated temperatures for 30 min. The flow rate is adjusted to maximum 1.0 l/min for carbonyl compound measurements. The measurement procedure specified in ISO 16000-3 shall be followed.
- 9.4.2.3. Turn off the pumps for the formaldehyde sampling and take the DNPH cartridges out of the sampling train to be analysed according to ISO 16000-3. Read and register the measurement volumes.
- 9.4.3. Driving mode
- 9.4.3.1. Before starting of driving mode, install the two VOC sorbent tubes and the two DNPH cartridges, check the sampling train for leaks, see paragraph 8.3.3. and purge the dead volume. Connect the exhaust pipe of the test vehicle with the ventilation system of test chamber to remove the exhaust gases outdoors.
- 9.4.3.2. Open the driver's door, start the engine. Turn on the air conditioning. Set vehicle temperature at 23 °C in the case of an automatic conditioning system or the lowest operation for semi-automatic and manual conditioning systems. For test vehicles without automatic air-conditioning systems, the fan is in highest performance mode with fresh-air ventilation, see Annex III. Close the driver's door. Complete these steps of the procedure in 60 seconds; meaning, after a maximum of 60 seconds of engine running the driver's door shall be closed. The doors and windows of test vehicle shall remain closed during the entire driving mode. Engine must be running during the entire mode at the

vehicle's idling speed with the minimum frequency of idling declared by the manufacturer.

- 9.4.3.3. After 60 seconds of closing the door, turn on the pumps of the four sampling trains, two for VOCs and two for carbonyl compounds, each in parallel. The sampling of air samples in the test vehicle cabin is performed at elevated temperature for 30 min. The flow rate is adjusted to maximum 0.2 l/min for VOCs and 1.0 l/min for carbonyl compound measurements. The measurement procedures specified in ISO 16000-6 (VOCs) and ISO 16000-3 (carbonyl compounds) shall be followed.
- 9.4.3.4. Turn off the engine. Stop the pumps of the sampling trains and the heating radiators/lamps. The sampling volumes shall be read and registered. The VOC sorbent tubes and DNPH cartridges shall be taken out of the sampling train for the analysis as specified in ISO 16000-6 and ISO 16000-3. Stop the continuous measurements for temperature and relative humidity. This is the end of the test mode.

10. Calculation, presentation of results, precision and uncertainty

Calculation and presentation of results are performed according to ISO 16000-6 and ISO 16000-3. The precision and uncertainty shall also be followed as specified in ISO 16000-6 and ISO 16000-3. Data reporting shall use the format in Annex IV. Additions to the report should be agreed on between the client and the laboratory.

11. Performance characteristics

The detection limits and standard deviations for VOCs given in ISO 16000-6 and for carbonyl compounds in ISO 16000-3 shall be met in this measurement procedure. The condition to meet these performance characteristics is that there are no contaminations or sink effects in the sampling lines. This shall be proven before the measurements and shall be documented.

12. Quality assurance/quality control

An appropriate level of quality control shall be employed following ISO 16000-3 and ISO 16000-6, namely:

- (a) Field blanks are prepared according to 9.2.4.;
- (b) The field blank level is acceptable if artefact peaks are no greater than 10 percent of the typical areas of the VOCs and carbonyl compounds of interest;
- (c) Desorption efficiency of VOCs and carbonyl compounds should be checked according to ISO 16000-3 and ISO 16000-6;
- (d) The collection efficiency can be assessed by using back-up tubes or taking samples of different sampling volumes less than the safe sampling volume;
- (e) Repeatability of the measuring method shall be determined, e.g. using collection and analysis of duplicate samples — a coefficient of variation ≤ 15 percent (ISO 16000-3 and ISO 16000-6) from the duplicate measurements should be reached;
- (f) The recovery of C₆ to C₁₆ hydrocarbons shall be 95 percent mass fraction (ISO 16000-6);

- (g) Documentation illustrating traceable calibrations for temperature, humidity, and flow measurements.

III. Emission entering to the vehicle cabin with exhaust gases

1. Purpose

The part III of the Mutual Resolution contains the provisions and harmonized test procedure for the measurement of interior air quality concerning the protection of the driver and passengers from harmful emissions entering the vehicle cabin with exhaust gases.

2. Scope and application

This part of Mutual Resolution applies to category 1-1 vehicle, as defined in the Special Resolution No. 1.²

3. Definitions

For the purpose of this part, the following definitions apply:

- 3.1. "*Test vehicle*" means the new vehicle from series production to be tested, mileage from 3,000 – 15,000 km;
- 3.2. "*Test substances*" means the substances to be measured and are carbon monoxide (CO), nitrogen monoxide (NO), nitrogen dioxide (NO₂);
- 3.3. "*Background concentration*" means the test substance concentrations in the ambient air when the test vehicle engine is OFF;
- 3.4. "*Idle test*" refers to the test in which test substances are sampled from the interior air of a test vehicle parked outside with its rear facing the wind direction and with the engine running at minimal idle speed;
- 3.5. "*Constant speed test*" refer to the test in which test substances are sampled from the interior air of a test vehicle moving at a constant speed;
- 3.6. "*Sampling point*" means a point between the headrests of the front seats.

4. Abbreviations

4.1. General abbreviations

VIAQ	Vehicle Interior Air Quality
HVAC	Heating, Ventilation and Air Conditioning

4.2. Chemical symbols and abbreviations

CO	Carbon monoxide [CAS#: 201230-82-2]
NO	Nitrogen monoxide [CAS#: 10102-43-9]
NO ₂	Nitrogen dioxide [CAS#: 10102-44-0]

5. General provisions

- 5.1. When instructed to include this test procedure in national standards, Contracting Parties are invited to adopt this part of Mutual Resolution

² ECE/TRANS/WP.29/1045, as amended by Amends. 1 and 2 (Special Resolution No. 1, www.unece.org/trans/main/wp29/wp29wgs/wp29gen/wp29resolutions.html)

regarding the measurement of interior air emissions entering into the cabin with exhaust gases.

- 5.2. This part of the Mutual Resolution does not hold regulatory status within Contracting Parties. Contracting Parties refer to the VIAQ recommendation when used for the assessment on vehicle interior air quality with the technical prescriptions of their own standards or regulations.
- 5.3. There are several test methods available for assessing vehicle interior air quality and this Mutual Resolution takes into account these existing standards. There are two type of tests, each with their own testing methodology. These test modes would be subject to optional acceptance by Contracting Parties depending on their situations. Contracting Parties may optionally decide on the test type.
- 5.4. This part of Mutual Resolution will encourage the improvement of vehicle body and air heating, ventilation and conditioning system design to increase air quality inside the passenger cabin.
- 5.5. Due to the different levels of development, different regional cultures, and the costs associated with interior air quality control technology, the regulatory stringency is expected to be different from region to region for the foreseeable future. The setting of interior pollutant concentration limit values, therefore, is not part of this recommendation for the time being.

6. Normative references

- 6.1. ISO 16000-1:2004 Indoor air – Part 1: General aspects of sampling strategy.
- 6.2. UN Regulation No. 83 - Rev.5 – Uniform provisions concerning the approval of vehicles with regard to the emission of pollutants according to engine fuel requirements (Annex 4a - Appendix 7).

7. Requirements for the test vehicle

- 7.1. Test vehicles should only be new vehicles from serial production. Used vehicles are not included. The selection of vehicles should be based on a worst case to minimize testing cost. For the purpose of emissions entering into the cabin with exhaust gases equipment for air purification is only allowed in the test cars if it is serial equipment.
- 7.2. The new vehicle should have been run in for between 3000 and 15000 km.
- 7.3. General inspection of the test vehicle should be performed before testing.

8. Requirements for the test apparatus, instrument, equipment and facility

- 8.1. Test facility.
 - 8.1.1. During the tests contamination from outside sources has to be prevented. Therefore, background measurements of the test substances have to be done before and after the test and in constant speed mode. Background concentrations have to be less than 25% of limit concentration. Difference between measurements of background concentrations before and after the test runs should not be more than 10% of limit concentration.
 - 8.1.2. For the purpose of an idle test it is possible to use natural wind (if within the specification) or an air blower to provide uniform air flow along the tested vehicle with a velocity of 2 ± 1 m/s.
 - 8.1.3. Test facility for idle test is an open parking zone.

- 8.1.4. Test road for constant speed test is a paved road with a gradient of maximum 6.0%.
- 8.2. Measurement method.
- 8.2.1. Measurement of test substances concentration in interior air is possible with using of either on-line or off-line measurement.
- 8.2.2. On-line measurement should be the preferred method and is carried out directly inside the tested vehicle with appropriate gas analysis equipment.
- 8.2.3. Off-line measurement should only be used in case of impossibility to maintain on-line measurement equipment inside the vehicle and is carried out by sampling of interior air probes in sealed bags.
- 8.3. Sampling method.
- 8.3.1. Sampling method in case of off-line measurement should be as follows:
- 8.3.2. The sampling system shall consist of: inverter for power supply to sampling system, air pump with flow rate of 2 l/min, air flow meter, clock, sampling bag of at least 30 l and connecting tubes.
- 8.3.3. The flow rate and duration of sampling is set in accordance with the required sample volume necessary for two parallel samples from one sampling point and is regulated by the requirements of the appropriate measurement procedures and the analytical parameters of the gas analyzer used.
- In case of emissions measurement from exhaust gases with on-line gas analyzers for CO, NO, NO₂ at least 5 measurements during 15 minutes have to be collected and then use averaged value as a result.
- 8.4. Test substance concentration measurement methods.
- 8.4.1. For nitrogen oxides (NO, NO₂):
- Chemiluminescence (CLD);
 - High-sensitive electrochemical detection (ECD).
- 8.4.2. For carbon monoxide (CO):
- Infrared photoacoustic spectroscopy (IRPAS);
 - Electrochemical detection (ECD);
 - None dispersive Infrared detector (NDIR).
- 8.5. Test substance concentration measurement limits.
- 8.5.1. The measuring equipment should provide the lower and upper limits of measurable concentrations of the test substances at the presence of other components as in the table below.

<i>Test substance</i>	<i>Lower limit of measurement, not less than, mg/m³</i>	<i>Upper limit of measurement, not more than, mg/m³</i>
Nitrogen monoxide NO	0.03	4.0
Nitrogen dioxide NO ₂	0.02	2.0
Carbon monoxide CO	1.0	50.0

- 8.6. Additional measurement equipment.
- 8.6.1. For tests using additional measurement equipment the following are to be used: thermometer, relative humidity meter, barometer, anemometer. Limit of permissible basic error for the above mentioned equipment is presented in the table.

<i>Parameter</i>	<i>Limit of permissible basic error</i>
Temperature	±1°C
Relative humidity	±2.5%
Atmospheric pressure	±0.1 kPa
Wind velocity	±(0.2 +2% from measured value) m/s
Flow rate	±5%

9. Test procedure, test mode, and test conditions

- 9.1. The preparation procedure.
 - 9.1.1. Take out cabin air filter and replace by new uncontaminated one.
 - 9.1.2. Check vehicle for tightness (sealings, windows, doors, trunk, roof). A vehicle with defective components should not be tested.
 - 9.1.3. Ensure exhaust pipe is representative of serial production. Visually check exhaust pipe for tightness.
 - 9.1.4. Before testing substance concentration, the measurement equipment or sampling system should be placed inside the test vehicle and warmed up ahead of the test start time in accordance with the equipment manual.
- 9.2. Test conditions.
 - 9.2.1. Ambient temperature in the range from -7°C to 30°C.
 - 9.2.2. Relative humidity from 30% to 90%.
 - 9.2.3. Atmospheric pressure from 85 to 110 kPa
- 9.3. Idle test.
 - 9.3.1. Ensure the wind speed is equal to 2±1 m/s in case of testing at natural air movement.
 - 9.3.2. Park the vehicle in a position so the wind direction, natural or simulated, achieves a linear speed of air perpendicular to the rear of the test vehicle.
 - 9.3.3. Locate the sensors to measure wind speed, temperature and humidity on the vehicle center line behind the test vehicle 0.5 m from the rear of the vehicle and 1.0 m from ground. During sampling, the sensors shall continually monitor at this location.
 - 9.3.4. Verify the uniformity of the wind to ensure it is constant across the width of the vehicle within the airflow tolerance and perpendicular to the rear of the vehicle. To verify the uniformity, measure the wind speed at two additional points 0.5 m on each side of the vehicle prior to sampling (see Annex V). To verify the wind is perpendicular to the vehicle, use a multi-axis flow meter or another method to verify that the cross wind is less than 15% of the wind airflow at all three locations prior to testing.
 - 9.3.5. Start the engine and warm-up vehicle by driving for a minimum 15 minutes.
 - 9.3.6. After warm-up, park the vehicle by backing into the previous position, such that the wind will force the exhaust gases back towards the vehicle. Set the vehicle's climate system to air conditioner: OFF; recirculation: ON and make sure that outside flaps do not open during test; temperature: manual and coolest level; fan: highest level; dashboard vent: all open and horizontal, and rear vents: closed.

- 9.3.7. With the engine off, ventilate vehicle for 5 minutes with all doors and windows open. Then close the doors and windows. Check the door seals, windows, doors, trunk, and roof.
- 9.3.8. During sampling, no people shall be inside the test vehicle. With the engine off, measure the background test substances concentrations. Start measuring wind speed, temperature and humidity at the center point 0.5 m behind the vehicle and 1.0 m from ground. Sample at least 5 air measurements from a location between the front seats during 15 minutes and then use the averaged value as a result. If sampling into a bag for off-line analysis then take two samples, each over 15 minutes, one sample for the reported measurement and one as a backup in case of failure. Stop all measurements and proceed to the idle measurement.
- 9.3.9. Open the door, start the engine, confirm the climate system settings, exit and close the door. This operation should take about one minute. With the engine running in an idle condition measure the vehicle interior test substances concentration level. Start measuring wind speed, temperature and humidity at the center point 0.5 m behind the vehicle and 1.0 m from ground. Sample at least 5 air measurements from a location between the front seats, take during 15 minutes. If sampling into a bag for post analysis then take two samples, each over 15 minutes, one sample for the reported measurement and one as a backup in case of failure.
- 9.3.10. Stop all measurements, open the door and switch engine off. Take another background measurement according to paragraph 9.3.8. Vehicle idle test is complete.
- 9.4. Constant speed test.
- 9.4.1. Start the engine and warm-up vehicle by driving for a minimum 15 minutes.
- 9.4.2. After warm-up, park the vehicle and set the vehicle's climate system to air conditioner: ON; recirculation: ON and make sure that outside flaps do not open during test; temperature setting: 20°C in automatic climate system or middle position for manual system; fan: highest level; dashboard vent: all open and horizontal, and rear seat vents: closed.
- 9.4.3. With the engine off, ventilate vehicle for 5 minutes with all doors and windows open. Then close the doors and windows. Check the door seals, windows, doors, trunk, and roof.
- 9.4.4. During sampling, no people shall be inside the test vehicle. With the engine off measure the background test substances concentrations. Start measuring wind speed, temperature and humidity at 1.0 m from ground. Sample at least 5 air measurements from a location between the front seats during 15 minutes and then use averaged value as a result. If sampling into a bag for on-site analysis then take two samples, each over 15 minutes, one sample for the reported measurement and one as a backup in case of failure. Stop all measurements and proceed to the constant speed measurement.
- 9.4.5. Start the engine, confirm the climate system settings. Only two persons are allowed inside the car during the driving test. Start driving and accelerate smoothly to a speed of 50 km/h. Measure the vehicle interior test substance concentration level. Sample at least 5 air measurements from a location between the front seats during 15 minutes. If sampling into a bag for post analysis then take two samples over 15 minutes, one sample for the reported measurement and one as a backup in case of failure.
- 9.4.6. Stop all measurements, park the vehicle and switch engine off. Take another background measurement according to paragraph 9.4.4. Vehicle constant speed test is complete.

10. Calculation, presentation of results, precision and uncertainty

- 10.1. Calculation of results: take at least 5 measurements from gas analyzers and use mean values as results.
- 10.2. Data reporting shall use the format in Annex VI. Additions to the report should be agreed on between the client and the laboratory.

11. Performance characteristics

- 11.1. Calibration procedure.
 - 11.1.1. Calibration should be done according to GTR 15.
 - 11.1.2. Calibration can be done by certified gas mixtures or preparation with a gas mixture generator (dynamic gas divider) used for the preparation of binary calibration gas mixtures within the permissible relative deviation of the dilution ratio from the nominal value within $\pm 2\%$; calibration gas mixtures (CGM) of calibrated components (NO in nitrogen, NO₂ in nitrogen, CO in nitrogen) with concentration error $\pm 5\%$; diluent gas in a balloon (synthetic air or nitrogen) with minimum purity 99.999%; connecting tubes from chemically inert materials.
 - 11.1.3. Preliminarily prepare 3 to 4 variants of dynamic gas divider valves setting to achieve analyzed gas concentration levels in the measurement range.
 - 11.1.4. Consistently set certain analyzed gas concentration level and measure it with calibrated gas analyzer. The difference between the set and measured concentration values (the main relative measurement error), should not exceed 25%.
 - 11.1.5. In case of exceedance of allowable measurement error, perform the gas analyzer calibration procedure in accordance to the user manual.
 - 11.1.6. One point calibration should be checked before and after each test set.
- 11.2. Cleaning procedure for Tedlar Bags.
 - 11.2.1. The Tedlar Bag shall be filled with Nitrogen 5.0 to the half of the bag volume. Afterwards the bag is sealed by closing the port. The bag containing Nitrogen is heated up to 100°C for 24 hours in a dry oven. Afterwards the bag will be evacuated, filled again with Nitrogen to check the blind values using adsorbents like e.g. DNPH, Tenax or Carbotrap. If the check is passed, the bag can be used, otherwise the cleaning procedure has to be repeated.

12. Quality assurance/quality control

- 12.1. The tests proceeded in accordance to paragraph 9. of part III are valid if all quality requirements listed in this paragraph are fulfilled.
- 12.2. Quality control requirements for idle test are listed in the table below.

<i>Subclauses</i>	<i>Description</i>	<i>Criterion</i>	<i>Frequency</i>	<i>Comments</i>
9.3.1 9.3.3	Wind speed	2±1 m/s	Each test	
9.3.2 9.3.4	Wind direction	±15 deg.	Each test	Perpendicular to rear of the test vehicle
9.3.3	Relative humidity	30 to 90%	Each test	
9.3.3	Atmospheric pressure	85 to 110 kPa	Each test	
9.3.3	Ambient temperature	-7 to +30°C	Each test	
9.3.4	Uniformity of the wind	±0,2 m/s	Each test	Measure the wind speed at two additional points 0.5 m on each side of the vehicle prior to sampling (see Annex V).
9.3.8	Background test substance concentrations	<25% of MAC*	Before test	Control for all measured test substances
9.3.10	Background test substance concentrations	<25% of MAC* and not more than 10% of MAC from concentrations before test (p.9.3.8)	After test	Control for all measured test substances

*MAC – maximal allowable concentration set by contracting party

12.3. Quality control requirements for constant speed test are listed in the table below.

<i>Subclauses</i>	<i>Description</i>	<i>Criterion</i>	<i>Frequency</i>	<i>Comments</i>
9.4.4	Ambient temperature	-7 to +30°C	Each test	
9.4.4	Relative humidity	30 to 90%	Each test	
9.4.4	Atmospheric pressure	85 to 110 kPa	Each test	
9.4.4	Background test substance concentrations	<25% of MAC*	Before test	Control for all measured test substances
9.4.6	Background test substance concentrations	<25% of MAC* and not more than 10% of MAC from concentrations	After test	Control for all measured test substances

		before test (p.9.4.4)		
--	--	--------------------------	--	--

*MAC – maximal allowable concentration set by contracting party

12.4. Quality control requirements for gas analysis are listed in the table below.

<i>Subclauses</i>	<i>Description</i>	<i>Criterion</i>	<i>Frequency</i>	<i>Comments</i>
11.1	Gas analyzer calibration	±25%	Daily	Procedure in accordance to 11.1
11.2.1	Tedlar bag cleaning	Bag within nitrogen is heated up to 100°C for 24 hours	Before each test	

Annex I

Whole vehicle chamber

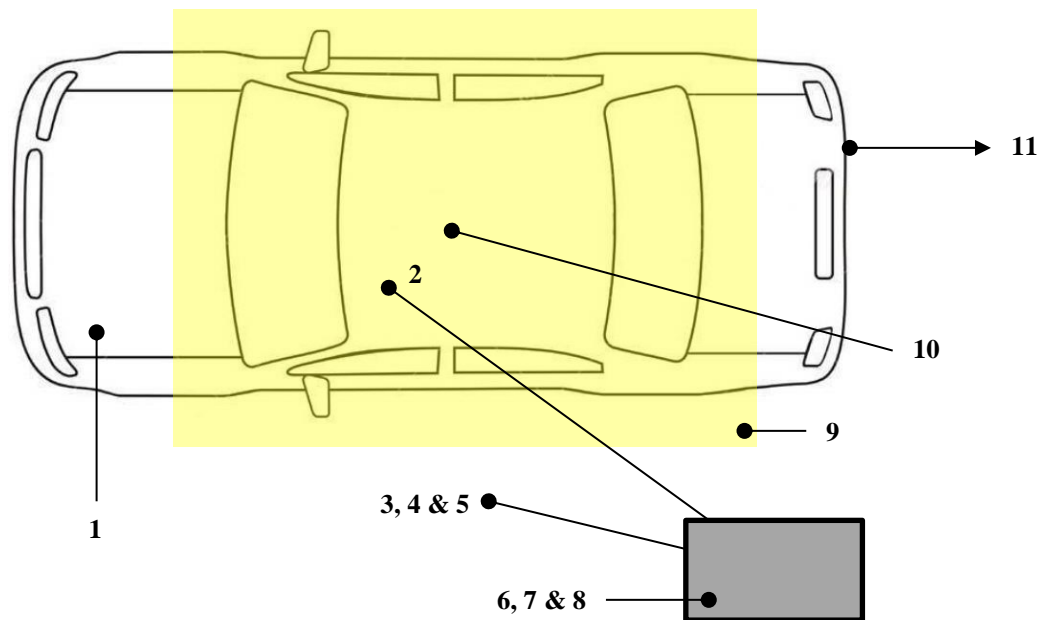

1. Test Vehicle.
2. Vehicle Sampling Point Location.
3. Chamber Sampling Point Location, 1 meter from vehicle 1 meter from floor.
4. Chamber Temperature Measurement Location.
5. Chamber Humidity Measurement Location.
6. Mass Flow Sample System.
7. Background Samples, 2 Tubes and 2 Cartridges, one is a backup.
8. Field Blank.
9. Solar Load Area, uniform area extending 0.5 meters beyond glass of vehicle.
10. Solar Load Measurement Location, top center of roof.
11. Exhaust Duct.

Annex II

Sampling position for measurement of emissions from interior materials

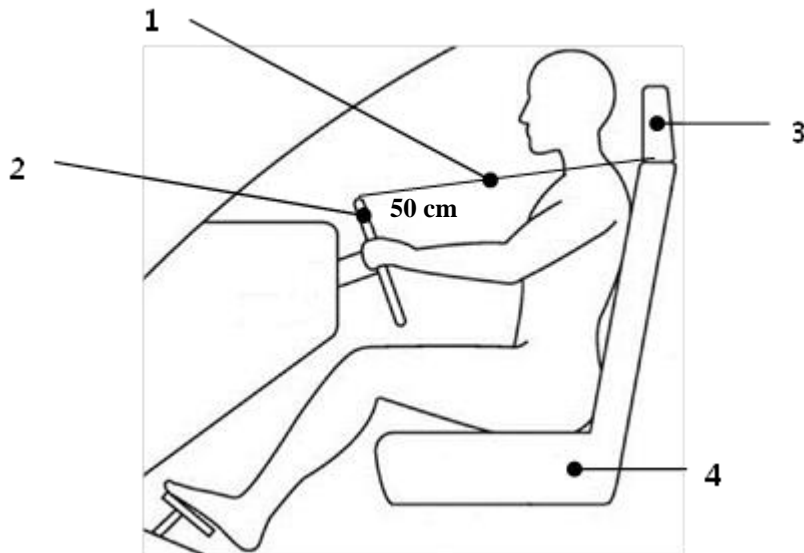

1. Vehicle Sampling Point Location, 50 centimeters from top of steering wheel to bottom of headrest.
2. Steering Wheel, in up and in most position.
3. Headrest in lowest position.
4. Seat in rearmost and lowest position with seatback at about 90° from seat bottom.

Annex III**Test schedule**

<i>Modes</i>	<i>Ambient Mode</i>					<i>Parking Mode</i>		<i>Driving Mode</i>
Supplementary Phases	Temperature Precondition	Sample	VOC Precondition	Soak	Sample	Soak	Sample	Sample
Duration	24 Hours	30 Minutes	30 to 60 Minutes	16 (+/- 1) Hours	30 Minutes	4 Hours	30 Minutes	30 Minutes
Start Time (hh:mm), Target times assume minimum of range	00:00	24:00	24:30	25:00	41:00	41:30	45:30	46:00
Chamber Temperature	20 °C to 30 °C	23.0 °C to 25.0 °C, as close as possible to 25.0 °C				As close as possible to 25.0 °C		
Chamber Humidity	50 % RH ± 10 % RH					As close as possible to 50 % RH		
Solar Load	OFF					400 ± 50 W/m ²		
Vehicle Age	28 ± 5 days and less than 80 km							
Vehicle Doors	CLOSED	OPEN	CLOSED				OPEN <1 min	
Vehicle Windows	CLOSED							
Vehicle Engine	OFF							ON
Vehicle Climate Settings Auto or Manual Systems	OFF							Auto or Face Mode
Air Conditioning	OFF							ON
Fan	OFF							Auto or High
Temperature Setting	OFF							23 °C or Lowest But Not MAX AC
Air Inlet Position	OPEN							Auto
Outlet Vents and Position	Fully OPEN and Upright							

<i>Modes</i>	<i>Ambient Mode</i>				<i>Parking Mode</i>		<i>Driving Mode</i>
Total Tube Samples ¹ Vehicle				2			2
Total Tube Samples ¹ Chamber	2						
Total Tube Samples ^{1,2} Field Blank	2						
Tube Sampling Times	30 Minutes			30 Minutes		30 Minutes	30 Minutes
Tube Sampling Flow Rate Ranges ³	0.1 L/min to 0.2 L/min			0.1 L/min to 0.2 L/min		0.1 L/min to 0.2 L/min	0.1 L/min to 0.2 L/min
Tube Sampling Volume Ranges ³	3 L to 6 L			3 L to 6 L		3 L to 6 L	3 L to 6 L
Total Cartridge Samples ¹ Vehicle				2		2	2
Total Cartridge Samples ¹ Chamber	2						
Total Cartridge Samples ^{1,2} Field Blank	2						
Cartridge Sampling Times	30 Minutes			30 Minutes		30 Minutes	30 Minutes
Cartridge Sampling Flow Rate Ranges ³	0.4 L/min to 1.0 L/min			0.4 L/min to 1.0 L/min		0.4 L/min to 1.0 L/min	0.4 L/min to 1.0 L/min
Cartridge Sample Volume Ranges ³	12 L To 30 L			12 L To 30 L		12 L To 30 L	12 L To 30 L

1. Analyse only one sample and report value. If both samples are analysed report the average.
2. Field Blanks are closed and shall not be opened to chamber or vehicle and no volume pulled through the sample. One common Field Blank result can be used for multiple vehicle tests per day of testing.
3. Sample flow rates and sample volumes shall be reported at standard temperature and pressure conditions. These same standard conditions shall be used in the calculation of VOC mass and concentration.

Annex IV

Test report of interior air emissions measurement from interior materials

Reporting Format and Data Exchange

The data exchange file shall be constructed as follows. VOC concentrations as well as any other relevant parameters shall be reported and exchanged as a csv-formatted data file. Parameter values shall be separated by a comma, ASCII-Code #h2C. The decimal marker of numerical values shall be a point, ASCII-Code #h2E. Lines shall be terminated by carriage return, ASCII-Code #h0D. No thousand separators shall be used.

Headers of the Reporting and Data Exchange File

<i>Line #</i>	<i>Parameter</i>	<i>Basic Data Type [A=Alpha or N=Numeric (max length, fractional digits)]</i>	<i>Data Type [Enumeration String, Decimal, Integer]</i>	<i>Total Digits</i>	<i>Fractional Digits</i>	<i>Minimum Value</i>	<i>Maximum Value</i>	<i>Allowed Values for: Enumeration or Description or Units</i>
1	Process Code	N(2)	Integer			0	99	Version of Test Report. 1 st dataset is N=0, highest value is the latest correction of existing dataset
2	Name of Witness	A(250)	String					Only if applicable. Full name of witness, company name and contact information for certification of test. Use "Self Certified" if no witness is required.
3	Test ID Code	A(50)	String					Serial Test Identification
4	Name of Vehicle Test Operator(s)	A(50)	String					Given (First) and Family (Last) Names
5	Name of Analytical Test Operator(s)	A(50)	String					First and last name of test operator
6	Vehicle Laboratory and Address	A(200)	String					Name of Vehicle Test Laboratory, Street, City, State, Country, Postal (ZIP) Code
7	Analytical Laboratory and Address	A(200)	String					Name of Sample Test Laboratory, Street, City, State, Country, Postal (ZIP) Code
8	Valid or Void	A(5)	String					Enter if the test value is void or valid
9	Test Comments	A(1000)	String					Test Report Comments

<i>Line #</i>	<i>Parameter</i>	<i>Basic Data Type [A=Alpha or N=Numeric (max length, fractional digits)]</i>	<i>Data Type [Enumeration String, Decimal, Integer]</i>	<i>Total Digits</i>	<i>Fractional Digits</i>	<i>Minimum Value</i>	<i>Maximum Value</i>	<i>Allowed Values for: Enumeration or Description or Units</i>
10	Production Date	A(10)	String					Ref. ISO 8601 (e.g. YYYY-MM-DD)
11	Transportation Date	A(10)	String					Ref. ISO 8601 (e.g. YYYY-MM-DD)
12	Storage Date	A(10)	String					Ref. ISO 8601 (e.g. YYYY-MM-DD)
13	Preconditioning Date	A(10)	String					Ref. ISO 8601 (e.g. YYYY-MM-DD)
14	Vehicle Test Date	A(10)	String					Ref. ISO 8601 (e.g. YYYY-MM-DD)
15	Analytical Test Date	A(10)	String					Ref. ISO 8601 (e.g. YYYY-MM-DD)
16	Elapsed days from the production date	N(3)	Integer					Time in days from production to end of sampling
17-20 ⁽¹⁾
21	Manufacturer Name	A(50)	String					Original Equipment Manufacturer (OEM)
22	Factory Name	A(50)	String					Place of Manufacturer
23	Vehicle Identification Number	A(17)	String					17-character vehicle identification number (VIN)
24	Vehicle Class (Category 1-1 Vehicle Only)	A(1)	Enumeration					A = Mini Vehicle B = Small Vehicle C = Medium Vehicle D = Large Vehicle E = Executive Vehicle F = Luxury Vehicle J = Sport Utility Vehicle (including off-road vehicles) M = Multi-Purpose Vehicle S = Sports Vehicle P = Small Pickup Truck T = Standard Pickup Truck
25	Model Name	A(50)	String					Manufacturer's Model Name
26	Exterior Color	A(50)	String					Paint Color
27	Interior Color	A(50)	String					Seat Trim Color
28	Interior Seat Material Type	A(50)	String					Description of Seat Cover Material (e.g.

Line #	Parameter	Basic Data Type [A=Alpha or N=Numeric (max length, fractional digits)]	Data Type [Enumeration String, Decimal, Integer]	Total Digits	Fractional Digits	Minimum Value	Maximum Value	Allowed Values for: Enumeration or Description or Units
								Leather, Cloth, color, etc.)
29	Odometer Reading	N(5)	Integer					Distance traveled [km] should be <80 km
30	Vehicle History	A(50)	String					Optional Description of Test Vehicle
31	Climate Control System Type/Characteristics	A(20)	String					Description of Climate Control System
32	AC Operator Control	A(1)	Enumeration					M = Manual A = Automatic
33-49 (1)
50	Chamber – Formaldehyde	N(4,1)	Decimal	5	1	0.0	9999.9	CAS#: 50-00-0 [µg/m ³]
51	Chamber – Acetaldehyde	N(4,1)	Decimal	5	1	0.0	9999.9	CAS#: 75-07-0 [µg/m ³]
52	Chamber – Acrolein	N(4,1)	Decimal	5	1	0.0	9999.9	CAS#: 107-02-8 [µg/m ³]
53	Chamber – Benzene	N(4,1)	Decimal	5	1	0.0	9999.9	CAS#: 71-43-2 [µg/m ³]
54	Chamber – Toluene	N(4,1)	Decimal	5	1	0.0	9999.9	CAS#: 108-88-3 [µg/m ³]
55	Chamber – Xylene	N(4,1)	Decimal	5	1	0.0	9999.9	CAS#: 1330-20-7 [µg/m ³]
56	Chamber – Ethylbenzene	N(4,1)	Decimal	5	1	0.0	9999.9	CAS#: 100-41-4 [µg/m ³]
57	Chamber – Styrene	N(4,1)	Decimal	5	1	0.0	9999.9	CAS#: 100-42-5 [µg/m ³]
58-69 (1)	Decimal	6	1	0.0	99999.9	...
70	Blank – Formaldehyde	N(4,1)	Decimal	5	1	0.0	9999.9	CAS#: 50-00-0 [µg/m ³]
71	Blank – Acetaldehyde	N(4,1)	Decimal	5	1	0.0	9999.9	CAS#: 75-07-0 [µg/m ³]
72	Blank – Acrolein	N(4,1)	Decimal	5	1	0.0	9999.9	CAS#: 107-02-8 [µg/m ³]

<i>Line #</i>	<i>Parameter</i>	<i>Basic Data Type [A=Alpha or N=Numeric (max length, fractional digits)]</i>	<i>Data Type [Enumeration String, Decimal, Integer]</i>	<i>Total Digits</i>	<i>Fractional Digits</i>	<i>Minimum Value</i>	<i>Maximum Value</i>	<i>Allowed Values for: Enumeration or Description or Units</i>
73	Blank – Benzene	N(4,1)	Decimal	5	1	0.0	9999.9	CAS#: 71-43-2 [µg/m ³]
74	Blank – Toluene	N(4,1)	Decimal	5	1	0.0	9999.9	CAS#: 108-88-3 [µg/m ³]
75	Blank – Xylene	N(4,1)	Decimal	5	1	0.0	9999.9	CAS#: 1330-20-7 [µg/m ³]
76	Blank – Ethylbenzene	N(4,1)	Decimal	5	1	0.0	9999.9	CAS#: 100-41-4 [µg/m ³]
77	Blank – Styrene	N(4,1)	Decimal	5	1	0.0	9999.9	CAS#: 100-42-5 [µg/m ³]
78-89 ⁽¹⁾	Decimal	6	1	0.0	99999.9	...
90	Ambient Mode Vehicle – Formaldehyde	N(4,1)	Decimal	5	1	0.0	9999.9	CAS#: 50-00-0 [µg/m ³]
91	Ambient Mode Vehicle – Acetaldehyde	N(4,1)	Decimal	5	1	0.0	9999.9	CAS#: 75-07-0 [µg/m ³]
92	Ambient Mode Vehicle – Acrolein	N(4,1)	Decimal	5	1	0.0	9999.9	CAS#: 107-02-8 [µg/m ³]
93	Ambient Mode Vehicle – Benzene	N(4,1)	Decimal	5	1	0.0	9999.9	CAS#: 71-43-2 [µg/m ³]
94	Ambient Mode Vehicle – Toluene	N(4,1)	Decimal	5	1	0.0	9999.9	CAS#: 108-88-3 [µg/m ³]
95	Ambient Mode Vehicle – Xylene	N(4,1)	Decimal	5	1	0.0	9999.9	CAS#: 1330-20-7 [µg/m ³]
96	Ambient Mode Vehicle – Ethylbenzene	N(4,1)	Decimal	5	1	0.0	9999.9	CAS#: 100-41-4 [µg/m ³]
97	Ambient Mode Vehicle – Styrene	N(4,1)	Decimal	5	1	0.0	9999.9	CAS#: 100-42-5 [µg/m ³]
98-109 ⁽¹⁾	Decimal	6	1	0.0	99999.9	...
110	Parking Mode Vehicle – Formaldehyde	N(4,1)	Decimal	5	1	0.0	9999.9	CAS#: 50-00-0 [µg/m ³]
111-129 ⁽¹⁾	Decimal	6	1	0.0	99999.9	...
130	Driving Mode Vehicle – Formaldehyde	N(4,1)	Decimal	5	1	0.0	9999.9	CAS#: 50-00-0 [µg/m ³]

<i>Line #</i>	<i>Parameter</i>	<i>Basic Data Type [A=Alpha or N=Numeric (max length, fractional digits)]</i>	<i>Data Type [Enumeration on String, Decimal, Integer]</i>	<i>Total Digits</i>	<i>Fractional Digits</i>	<i>Minimum Value</i>	<i>Maximum Value</i>	<i>Allowed Values for: Enumeration or Description or Units</i>
131	Driving Mode Vehicle – Acetaldehyde	N(4,1)	Decimal	5	1	0.0	9999.9	CAS#: 75-07-0 [µg/m ³]
132	Driving Mode Vehicle – Acrolein	N(4,1)	Decimal	5	1	0.0	9999.9	CAS#: 107-02-8 [µg/m ³]
133	Driving Mode Vehicle – Benzene	N(4,1)	Decimal	5	1	0.0	9999.9	CAS#: 71-43-2 [µg/m ³]
134	Driving Mode Vehicle – Toluene	N(4,1)	Decimal	5	1	0.0	9999.9	CAS#: 108-88-3 [µg/m ³]
135	Driving Mode Vehicle – Xylene	N(4,1)	Decimal	5	1	0.0	9999.9	CAS#: 1330-20-7 [µg/m ³]
136	Driving Mode Vehicle – Ethylbenzene	N(4,1)	Decimal	5	1	0.0	9999.9	CAS#: 100-41-4 [µg/m ³]
137	Driving Mode Vehicle – Styrene	N(4,1)	Decimal	5	1	0.0	9999.9	CAS#: 100-42-5 [µg/m ³]
138-149 ⁽¹⁾	Decimal	6	1	0.0	99999.9	...
150	Storage Temperature	N(2,1)	Decimal	3	1	0.0	99.9	Unit [°C]
151	Storage Humidity	N(2,1)	Decimal	3	1	0.0	99.9	Unit [% RH]
152	Preconditioning Temperature	N(2,1)	Decimal	3	1	0.0	99.9	Unit [°C]
153	Preconditioning Humidity	N(2,1)	Decimal	3	1	0.0	99.9	Unit [% RH]
154	Ambient Mode Vehicle Cabin Temperature	N(2,1)	Decimal	3	1	0.0	99.9	Unit [°C]
155	Ambient Mode Vehicle Cabin Humidity	N(2,1)	Decimal	3	1	0.0	99.9	Unit [% RH]
156	Ambient Mode Chamber Temperature	N(2,1)	Decimal	3	1	0.0	99.9	Unit [°C]
157	Ambient Mode Chamber Humidity	N(2,1)	Decimal	3	1	0.0	99.9	Unit [% RH]

<i>Line #</i>	<i>Parameter</i>	<i>Basic Data Type [A=Alpha or N=Numeric (max length, fractional digits)]</i>	<i>Data Type [Enumeration String, Decimal, Integer]</i>	<i>Total Digits</i>	<i>Fractional Digits</i>	<i>Minimum Value</i>	<i>Maximum Value</i>	<i>Allowed Values for: Enumeration or Description or Units</i>
158	Parking Mode Vehicle Cabin Temperature	N(3,1)	Decimal	4	1	0.0	999.9	Unit [°C]
159	Parking Mode Vehicle Cabin Humidity	N(2,1)	Decimal	3	1	0.0	99.9	Unit [% RH]
160	Parking Mode Chamber Temperature	N(2,1)	Decimal	3	1	0.0	99.9	Unit [°C]
161	Parking Mode Chamber Humidity	N(2,1)	Decimal	3	1	0.0	99.9	Unit [% RH]
162	Driving Mode Vehicle Cabin Temperature	N(2,1)	Decimal	3	1	0.0	99.9	Unit [°C]
163	Driving Mode Vehicle Cabin Humidity	N(2,1)	Decimal	3	1	0.0	99.9	Unit [% RH]
164	Driving Mode Chamber Temperature	N(2,1)	Decimal	3	1	0.0	99.9	Unit [°C]
165	Driving Mode Chamber Humidity	N(2,1)	Decimal	3	1	0.0	99.9	Unit [% RH]
166-179 ⁽¹⁾

(1) - Additional parameters may be added here to characterize test conditions.

Annex V

Idle test setup

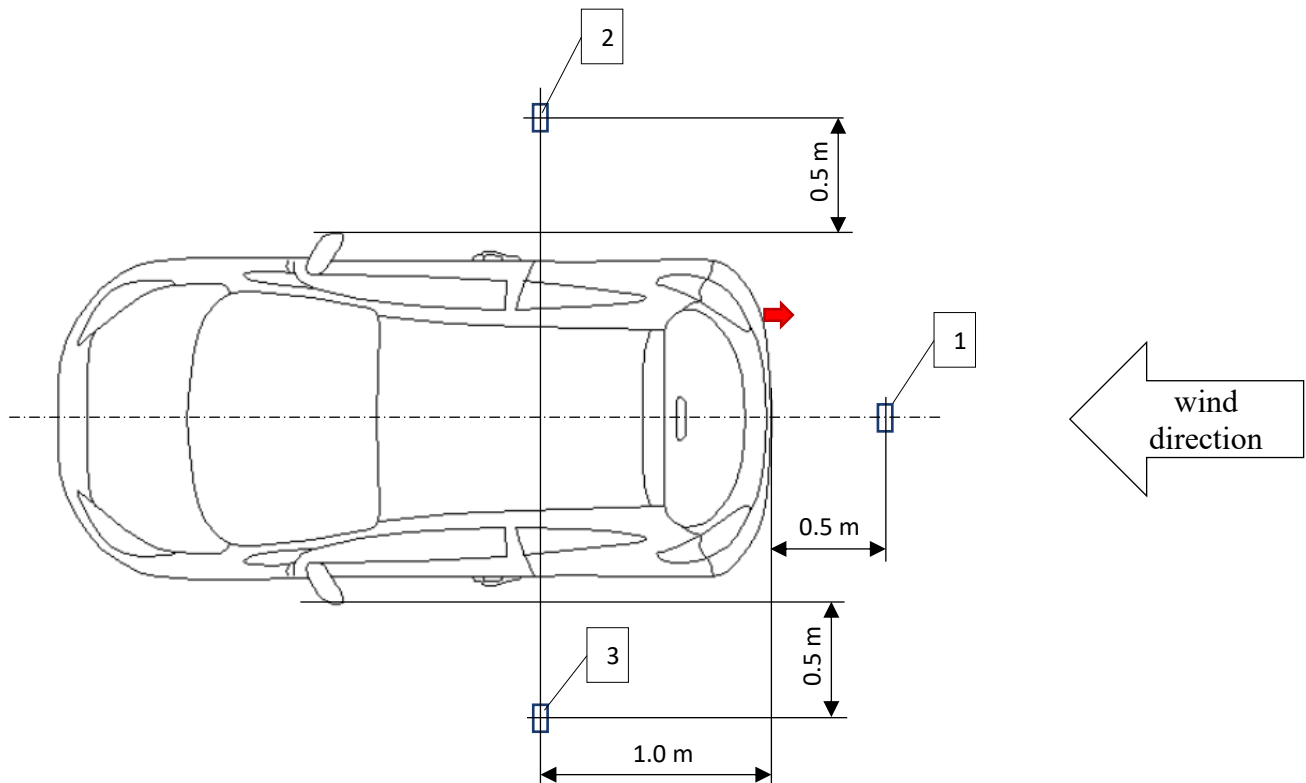

1. Anemometer (constantly monitor center location).
- 2,3. Anemometers (side location).

Annex VI

Test report of emissions entering to the vehicle cabin with exhaust gases

Reporting Format and Data Exchange

The data exchange file shall be constructed as follows. Test substance concentrations as well as any other relevant parameters shall be reported and exchanged as a csv-formatted data file. Parameter values shall be separated by a comma, ASCII-Code #h2C. The decimal marker of numerical values shall be a point, ASCII-Code #h2E. Lines shall be terminated by carriage return, ASCII-Code #h0D. No thousand separators shall be used.

Headers of the Reporting and Data Exchange File

<i>Line #</i>	<i>Parameter</i>	<i>Basic Data Type [A=Alpha or N=Numeric (max length, fractional digits)]</i>	<i>Data Type [Enumeration String, Decimal, Integer]</i>	<i>Total Digits</i>	<i>Fractional Digits</i>	<i>Minimum Value</i>	<i>Maximum Value</i>	<i>Allowed Values for: Enumeration or Description or Units</i>
1	Process Code	N(2)	Integer			0	99	Version of Test Report. 1 st dataset is N=0, highest value is the latest correction of existing dataset
2	Name of Witness	A(250)	String					Only if applicable. Full name of witness, company name and contact information for certification of test. Use "Self-Certified" if no witness is required.
3	Test ID Code	A(50)	String					Serial Test Identification
4	Name of Vehicle Test Operator(s)	A(50)	String					Given (First) and Family (Last) Names
5	Name of Analytical Test Operator(s)	A(50)	String					First and last name of test operator
6	Vehicle Laboratory and Address	A(200)	String					Name of Vehicle Test Laboratory, Street, City, State, Country, Postal (ZIP) Code
7	Analytical Laboratory and Address	A(200)	String					Name of Sample Test Laboratory, Street, City, State, Country, Postal (ZIP) Code
8	Valid or Void	A(5)	String					Enter if the test value is void or valid
9	Test Comments	A(1000)	String					Test Report Comments

<i>Line #</i>	<i>Parameter</i>	<i>Basic Data Type [A=Alpha or N=Numeric (max length, fractional digits)]</i>	<i>Data Type [Enumeration String, Decimal, Integer]</i>	<i>Total Digits</i>	<i>Fractional Digits</i>	<i>Minimum Value</i>	<i>Maximum Value</i>	<i>Allowed Values for: Enumeration or Description or Units</i>
10	Production Date	A(10)	String					Ref. ISO 8601 (e.g. YYYY-MM-DD)
11	Vehicle Test Date	A(10)	String					Ref. ISO 8601 (e.g. YYYY-MM-DD)
12	Analytical Test Date	A(10)	String					Ref. ISO 8601 (e.g. YYYY-MM-DD)
13	Manufacturer Name	A(50)	String					Original Equipment Manufacturer (OEM)
14	Factory Name	A(50)	String					Place of Manufacturer
15	Vehicle Identification Number	A(17)	String					17-character vehicle identification number (VIN)
16	Vehicle Class (Category 1-1 Vehicle Only)	A(1)	Enumeration					A = Mini Vehicle B = Small Vehicle C = Medium Vehicle D = Large Vehicle E = Executive Vehicle F = Luxury Vehicle J = Sport Utility Vehicle (including off-road vehicles) M = Multi-Purpose Vehicle S = Sports Vehicle P = Small Pickup Truck T = Standard Pickup Truck
17	Model Name	A(50)	String					Manufacturer's Model Name
18	Exterior Color	A(50)	String					Paint Color
19	Odometer Reading	N(5)	Integer					Distance traveled [km] should be from 3000 till 15000 km
20	Vehicle History	A(50)	String					Optional Description of Test Vehicle
21	Climate Control System Type/Characteristics	A(20)	String					Description of Climate Control System
22	AC Operator Control	A(1)	Enumeration					M = Manual A = Automatic
23	Cabin Filter Type	A(1)	Enumeration					D = Dust Filter C = Carbon Filter N = No Filter

<i>Line #</i>	<i>Parameter</i>	<i>Basic Data Type [A=Alpha or N=Numeric (max length, fractional digits)]</i>	<i>Data Type [Enumeration on String, Decimal, Integer]</i>	<i>Total Digits</i>	<i>Fractional Digits</i>	<i>Minimum Value</i>	<i>Maximum Value</i>	<i>Allowed Values for: Enumeration or Description or Units</i>
24	Cabin Air Cleaning Device	A(1)	Enumeration					N = Not Equipped Y = Equipped
25-29 ⁽¹⁾
30	Wind speed	N(2,1)	Decimal	3	1	0.0	99.9	[m/s]
31	Ambient temperature	N(2,1)	Decimal	3	1	-99.9	+99.9	[deg. Celsius]
32	Ambient pressure	N(3,1)	Decimal	4	1	0.0	999.9	[kPa]
33	Relative humidity	N(2,1)	Decimal	3	1	0.0	99.9	[percent]
34-39 ⁽¹⁾
40	Background – Carbon Monoxide – before test	N(4,1)	Decimal	5	1	0.0	9999.9	CAS#: 201230-82-2 [mg/m ³]
41	Background – Nitrogen Monoxide – before test	N(4,1)	Decimal	5	1	0.0	9999.9	CAS#: 10102-43-9 [µg/m ³]
42	Background – Nitrogen Dioxide – before test	N(4,1)	Decimal	5	1	0.0	9999.9	CAS#: 10102-44-0 [µg/m ³]
43	Background – Carbon Monoxide – after test	N(4,1)	Decimal	5	1	0.0	9999.9	CAS#: 201230-82-2 [mg/m ³]
44	Background – Nitrogen Monoxide – after test	N(4,1)	Decimal	5	1	0.0	9999.9	CAS#: 10102-43-9 [µg/m ³]
45	Background – Nitrogen Dioxide – after test	N(4,1)	Decimal	5	1	0.0	9999.9	CAS#: 10102-44-0 [µg/m ³]
46-49 ⁽¹⁾
50	Idle Test – Carbon Monoxide	N(4,1)	Decimal	5	1	0.0	9999.9	CAS#: 201230-82-2 [mg/m ³]
51	Idle Test – Nitrogen Monoxide oxide	N(4,1)	Decimal	5	1	0.0	9999.9	CAS#: 10102-43-9 [µg/m ³]

<i>Line #</i>	<i>Parameter</i>	<i>Basic Data Type [A=Alpha or N=Numeric (max length, fractional digits)]</i>	<i>Data Type [Enumeration String, Decimal, Integer]</i>	<i>Total Digits</i>	<i>Fractional Digits</i>	<i>Minimum Value</i>	<i>Maximum Value</i>	<i>Allowed Values for: Enumeration or Description or Units</i>
52	Idle Test – Nitrogen Dioxide	N(4,1)	Decimal	5	1	0.0	9999.9	CAS#: 10102-44-0 [µg/m ³]
53-59 ⁽¹⁾
60	Constant Speed Test – Carbon Monoxide	N(4,1)	Decimal	5	1	0.0	9999.9	CAS#: 201230-82-2 [mg/m ³]
61	Constant Speed Test – Nitrogen monoxide	N(4,1)	Decimal	5	1	0.0	9999.9	CAS#: 10102-43-9 [µg/m ³]
62	Constant Speed Test – Nitrogen Dioxide	N(4,1)	Decimal	5	1	0.0	9999.9	CAS#: 10102-44-0 [µg/m ³]
63-69 ⁽¹⁾

(1) Additional parameters may be added here to characterize test conditions.