



C L E P A
*European Association of
Automotive Suppliers*

Informal Document No. 1
(80th GRSG session 2-6 April 2001,
agenda item 6)

Note by the secretariat: This document is identical to document TRANS/WP.29/GRSG/2000/29, but clearly marking the differences with Regulation No. 43 (TRANS/WP.29/GRSG/58, para. 58)

DRAFT
(28 June 1999)

**GLOBAL STANDARD FOR
SAFETY GLAZING MATERIALS
FOR MOTOR VEHICLES AND
MOTOR VEHICLE EQUIPMENT**

SAFETY STANDARD

**GLOBAL STANDARD FOR SAFETY GLAZING MATERIALS FOR MOTOR VEHICLES AND MOTOR VEHICLE
EQUIPMENT – SAFETY STANDARD**

CONTENTS

REGULATION

1. Scope
2. Definitions
3. Markings
4. General Requirements
5. Particular Requirements
6. Tests

ANNEXES

- Annex 1** — Windscreen Design Parameters
- Annex 2** — Identification Marks for Safety Glazing Materials
- Annex 3** — General Test Conditions
- Annex 4** — Toughened Glass Windscreens
- Annex 5** — Uniformly Toughened Glass Panes
- Annex 6** — Ordinary Laminated Glass Windscreens
- Annex 7** — Laminated Glass Panes other than Windscreens
- Annex 8** — Treated Laminated Glass Windscreens
- Annex 9** — Safety Glass Panes Faced with Plastics Material (on the inner face)
- Annex 10** — Glass Plastics Windscreens
- Annex 11** — Glass Plastics Panes other than Windscreen
- Annex 12** — Double Glazed Units
- Annex 13** — Rigid Plastic Glazings other than Windscreens
- Annex 14** — Flexible Plastic Glazings other than Windscreens
- Annex 15** — Rigid Plastic Double-Glazed Units
- Annex 16** — Measurement of the Heights of Segment and Position of the Points of Impact
- Annex 17** — Procedures for Determining Test Areas on Windscreens of [M₁ Category Vehicles] in Relation to the "V" Points
- Annex 18** — Procedure for Determining the "H" Point and the Actual Torso Angle for Seating Positions in Motor Vehicles.

GLOBAL STANDARD FOR SAFETY GLAZING MATERIALS FOR MOTOR VEHICLES AND MOTOR VEHICLE EQUIPMENT – SAFETY STANDARD

1. SCOPE

- 1.1. This Standard applies to safety glazing materials intended for installation as windscreens or other panes, or as partitioning, on power-driven vehicles and their trailers, to the exclusion however of glazings for lighting and light-signalling devices and instrument panels, and of special bullet or aggression resistant glazings.

This Standard does not concern the installation of safety glazing materials on power-driven vehicles and their trailers or double windows.

2. DEFINITIONS

For the purposes of this Standard:—

- 2.1. "**Toughened-Glass Pane**" means a glass pane consisting of a single layer of glass which has been subjected to special treatment to increase its mechanical strength and to condition its fragmentation after shattering;
- 2.2. "**Laminated-Glass Pane**" means a glass pane consisting of two or more layers of glass held together by one or more interlayers of plastics material; it may be:-
- 2.2.1. "**Ordinary**", when none of the layers of glass of which it is composed has been treated; or
- 2.2.2. "**Treated**", when at least one of the layers of glass of which it is composed has been specially treated to increase its mechanical strength and to condition its fragmentation after shattering;
- 2.3. "**Safety-Glass Pane Faced with Plastic Material**" means a glass pane as defined in Paragraph 2.1 or 2.2 with a layer of plastics material on its inner face;
- 2.4. "**Glass-Plastics Pane**" means a pane of laminated glass having one layer of glass and one or more layers of plastics material, at least one of which acts as interlayer. The plastics layer(s) shall be on the inner face when the glazing is fitted on the vehicle;
- 2.5. "**Plastic Glazing**" is a glazing material that contains as an essential ingredient one or more organic polymeric substances of large molecular weight, is solid in its finished state and, at some stage in its manufacture or processing into finished articles, can be shaped by flow;
- 2.5.1. "**Rigid Plastic Glazing**" means a plastic glazing material which does not deflect vertically more than 50 mm in the flexibility test (A 3/12);
- 2.5.2. "**Flexible Plastic Glazing**" means a plastic glazing material which deflects vertically more than 50 mm in the flexibility test (A 3/12);
- 2.6. "**Double Window**" means an assembly of two glazing panes separately installed within the same opening in the vehicle;
- 2.7. "**Double-Glazed Unit**" means an assembly of two glazing panes permanently assembled in manufacture and separated by a uniform gap;
- 2.7.1. "**Symmetrical Double-Glazing**" means a double-glazed unit where the two component glazings are of the same type (toughened glass, laminated glass, rigid plastic) and have the same principal and/or secondary

characteristics;

- 2.7.2. **"Asymmetrical Double-Glazing"** means a double-glazed unit where the two component glazings are of different type (toughened glass, laminated glass, rigid plastic) or have different principal and/or secondary characteristics;
- 2.8. **"Principal Characteristic"** means a characteristic which appreciably modifies the optical and/or mechanical properties of a safety glazing material in a way not without significance to the function which it is intended to perform in a vehicle. The term also covers the trade name of the glazing manufacturer;
- 2.9. **"Secondary Characteristic"** means a characteristic capable of modifying the optical and/or mechanical properties of a safety glazing material in a way which is of significance to the function which it is intended to perform in a vehicle. The extent of such modification is assessed in relation to the indices of difficulty;
- 2.10. The term **"Indices of Difficulty"** covers a two-stage grading system applying to the variations observed in practice in each secondary characteristic. A change from Index "1" to Index "2" indicates the need for additional tests;
- 2.11. **"Developed Area of a Windscreen"** means the minimum rectangular area of glass from which a windscreen can be manufactured [see Annex 1];
- 2.12. **"Inclination Angle of a Windscreen"** means the angle included between on the one hand a vertical line and on the other hand a straight line passing through the top and bottom edges of the windscreen, both lines being contained in a vertical plane containing the longitudinal axis of the vehicle [see Annex 1];
- 2.12.1. Measurement of the inclination angle shall be performed on a vehicle standing on level ground, and in the case of a passenger-transport vehicle the vehicle shall be in running order, shall be fully charged with fuel, coolant and lubricant, and shall be equipped with tools and the spare wheel or wheels (if they are provided as standard equipment by the vehicle manufacturer); allowance shall be made for the mass of a driver, and also, in the case of a passenger-transport vehicle, for that of one front-seat passenger, the mass of the driver and that of the passenger each being deemed to be 75 ± 1 kg;
- 2.12.2. Vehicles equipped with hydropneumatic, hydraulic or pneumatic suspension or with a device for automatic adjustment of ground clearance according to load shall be tested in the normal running conditions specified by the manufacturer;
- 2.13. **"Group of Windscreens"** means a group comprising windscreens of differing sizes and shapes subjected to an examination of their mechanical properties, their mode of fragmentation and their behaviour in environmental-aggression resistance tests;
- 2.13.1. **"Flat Windscreen"** means a windscreen exhibiting no normal curvature resulting in a height of segment greater than 10 mm per linear metre;
- 2.13.2. **"Curved Windscreen"** means a windscreen exhibiting a normal curvature resulting in a height of segment greater than 10 mm per linear metre;
- 2.14. **"Height of Segment 'h'"** means the maximum distance, measured at right angles approximately to the glass pane, separating the inner surface of the pane from a plane passing through the ends of the pane. (See Annex 16, Figure 1);
- 2.15. **"Type of Safety Glazing Material"** means a glazing as defined in Paragraphs 2.1. to 2.7. not exhibiting any essential differences, with respect, in particular, to the principal and secondary characteristics defined in Annexes 4 to 15;
- 2.15.1. Although a change in the principal characteristics implies that the product is of a new type, it is recognised that in certain cases a change in shape and dimension does not necessarily require a complete set of tests to be carried out. For certain of the tests prescribed in the individual Annexes, glazings may be grouped if it

evident that they have similar principal characteristics;

- 2.15.2. Types of glazing exhibiting differences only as regards their secondary characteristics may be deemed to be of the same type; certain tests may however be carried out on samples of such panes if the performance of those tests is explicitly stipulated in the test conditions;
- 2.16. "**Curvature 'r'**" means the approximate value of the smallest radius of arc of the windscreen as measured in the most curved area;
- 2.17. "**HIC**" (**Head Injury Criteria**) value means a value for the characteristics of skull-brain injury arising from the deceleration forces which result from a blunt perpendicular impact with the glazing;
- 2.18. "**Safety glazing material requisite for driver visibility**" means safety glazing material used as a windscreen or a front side or door window mounted in the 180° angle forward to the driver;
- 2.19. "**Shadeband**" means an area outside the requisite vision area that has had the luminous transmittance reduced by methods such as interlayer tinting or ceramic frit application in order to reduce glare;
- 2.20. "**Obscuration Band**" means an opaque ceramic frit section around the periphery of the glazing to protect the attaching adhesive from UV degradation and to mask that adhesive and underlying body components;
- 2.21. "**Interlayer**" means a plastic material used to hold together the layers of a laminate.

3. **MARKINGS**

- 3.1. Every piece of safety glazing material shall bear the trade name of the glazing manufacturer. The marking shall be clearly legible and indelible.

4. **GENERAL REQUIREMENTS**

- 4.1. All glazing materials shall be such that, in the event of shattering, the danger of bodily injury is reduced as far as possible. All glazing materials shall be sufficiently resistant to the incidents likely to occur in normal traffic, and to atmospheric and temperature conditions, chemical action, combustion and abrasion.
- 4.2. Safety glazing materials shall in addition be sufficiently transparent, shall not cause any noticeable distortions of objects as seen through the windscreen, and shall not give rise to any confusion between the colours used in road-traffic signs and signals. In the event of the windscreen shattering, the driver must still be able to see the road clearly enough to be able to brake and stop his vehicle safely.

5. **PARTICULAR REQUIREMENTS**

All types of safety glazing shall, depending on the category to which they belong, comply with the following particular requirements:—

- 5.1. As regards toughened-glass windscreens, the requirements contained in Annex 4;
- 5.2. As regards uniformly-toughened glass panes, the requirements contained in Annex 5;
- 5.3. As regards ordinary laminated-glass windscreens, the requirements contained in Annex 6;
- 5.4. As regards ordinary laminated-glass panes other than windscreens, the requirements contained in Annex 7;
- 5.5. As regards treated laminated-glass windscreens, the requirements contained in Annex 8.
- 5.6. As regards safety-glass panes faced with plastics material, in addition to the relevant requirements listed above, the requirements contained in Annex 9;
- 5.7. As regards glass-plastics windscreens, the requirements contained in Annex 10;

- 5.8. As regards glass-plastics panes other than windscreens, the requirements contained in Annex 11;
- 5.9. As regards double-glazed units, the requirements contained in Annex 12.
- 5.10. As regards rigid plastic glazings, the requirements contained in Annex 13.
- 5.11. As regards flexible plastic glazings, the requirements contained in Annex 14.
- 5.12. As regards rigid plastic double-glazed units, the requirements contained in Annex 15.

6. TESTS

6.1. The following tests are prescribed in this Regulation:—

6.1.1. *Fragmentation Test*

The purpose of this test is :—

6.1.1.1. To assess the liability of fragments of safety glazing to cause injury in the event of fracture.

6.1.1.2. In the case of windscreens, to check residual visibility after shattering.

6.1.2. *Mechanical Strength Test*

6.1.2.1. *Ball-impact Test*

There are two forms of test, one using a 227 g ball and one using a 2 260 g ball.

6.1.2.1.1. 227 g ball test: The purpose of this test is to assess the adhesion of the interlayer of laminated glass and the mechanical strength of uniformly-toughened glass and plastic glazings.

6.1.2.1.2. 2 260 g ball test: The purpose of this test is to assess ball penetration resistance of laminated glass.

6.1.2.2. *Headform Test*

The purpose of this test is to verify the compliance of safety glazing with the requirements relating to the limitation of injury in the event of impact of the head against the windscreen, laminated glass and panes of glass-plastic and rigid plastic other than windscreens, together with the double-glazed units used in the side windows.

6.1.3. *Test of Resistance to the Environment*

6.1.3.1. *Test of resistance to Abrasion*

The purpose of this test is to determine whether the resistance of a safety glazing to abrasion exceeds a specified value.

6.1.3.2. *Test of resistance to High Temperature*

The purpose of this test is to determine whether the safety glazing material will withstand exposure to high temperatures over an extended period of time without its appearance becoming substantially altered.

6.1.3.3. *Resistance-to-Radiation Test*

The purpose of this test is to determine whether the light transmittance of laminated-glass panes, glass-plastics panes or glass panes faced with plastics material when exposed to radiation over an extended

period of time is significantly reduced thereby or whether the glazing is significantly discoloured.

6.1.3.4. *Resistance-to-Humidity Test*

The purpose of this test is to determine whether laminated-glass panes, glass-plastic panes, glass panes faced with plastic material and rigid plastic material will withstand, without significant deterioration, the effects of prolonged exposure to atmospheric humidity.

6.1.3.5. *Resistance-to-Temperature-Changes Test*

The purpose of this test is to check that plastics material(s) used in safety glazing as defined in Paragraphs 2.3. and 2.4. above will withstand the effects of prolonged exposure to extremes of temperature without significant deterioration.

6.1.3.6. *Resistance to Simulated Weathering Test*

The purpose of this test is to verify that plastic safety glazing is resistant to simulated weathering conditions.

6.1.3.7. *Cross Cut Test*

The purpose of this test is to examine whether any abrasive resistant coating of a rigid plastic glazing has sufficient adherence.

6.1.4. *Optical Qualities*

6.1.4.1. *Light-Transmission Test*

The purpose of this test is to determine whether the regular transmission of the safety glazing exceeds a specified value.

6.1.4.2. *Optical-Distortion Test*

The purpose of this test is to verify that the distortion of objects as seen through the windscreen is not of such extent as to be likely to confuse the driver.

6.1.4.3. *Secondary-Image-Separation Test*

The purpose of this test is to verify that the angular separation of the secondary image from the primary image does not exceed a specified value.

6.1.5. *Burning-Behaviour (Fire-Resistance) Test*

The purpose of this test is to verify that a safety glazing material as defined in Paragraphs 2.3, 2.4 and 2.5. above has a sufficiently low burn rate.

6.1.6. *Test of Resistance to Chemicals*

The purpose of this test is to determine whether the safety glazing material as defined in Paragraphs 2.3, 2.4 and 2.5. above will withstand the effects of exposure to chemicals likely to be normally present or used within the vehicle (e.g. cleaning compounds) without significant deterioration.

6.1.7. *Flexibility and Fold Test*

The purpose of this test is to determine whether a plastic glazing material falls within the rigid or flexible category.

6.2. **Tests Prescribed for Glazing Materials of the Categories Defined in Paragraphs 2.1. to 2.5. of this**

Regulation

6.2.1. Safety glazing materials shall be subjected to the tests listed in the following tables: 6.2.1.1 and 6.2.1.2.

6.2.1.1. Safety Glass panes shall be subjected to the tests in the following table.

Tests	Windscreen							Glass panes other than windscreens		
	Toughened glass		Ordinary laminated glass		Treated laminated glass		Glass-plastics	Toughened glass	Laminated glass	Glass-plastics
	I	I-P	II	II-P	III	III-P	IV			
Fragmentation:	A4/2	A4/2	-	-	A8/4	A8/4	-	A5/2	-	-
Mechanical strength										
- 227 g ball	-	-	A6/4.3	A6/4.3	A6/4.3	A6/4.3	A6/4.3	A5/3.1	A7/4	A7/4
- 2 260 g ball	-	-	A6/4.2	A6/4.2	A6/4.2	A6/4.2	A6/4.2	-	-	-
Headform test 1/	A4/3	A4/3	A6/3	A6/3	A6/3	A6/3	A10/3	-	A7/3	A11/3
Abrasion										
Outer face	-	-	A6/5.1	A6/5.1	A6/5.1	A6/5.1	A6/5.1	-	A6/5.1	A6/5.1
Inner face	-	A9/2	-	A9/2	-	A9/2	A9/2	A9/2 2/	A9/2 2/	A9/2
High temperature	-	-	A3/5	A3/5	A3/5	A3/5	A3/5	-	A3/5	A3/5
Radiation	-	A3/6	A3/6	A3/6	A3/6	A3/6	A3/6	-	A3/6	A3/6
Humidity	-	A3/7	A3/7	A3/7	A3/7	A3/7	A3/7	A3/7 2/	A3/7	A3/7
Light transmission	A3/9.1	A3/9.1	A3/9.1	A3/9.1	A3/9.1	A3/9.1	A3/9.1	A3/9.1	A3/9.1	A3/9.1
Optional distortion	A3/9.2	A3/9.2	A3/9.2	A3/9.2	A3/9.2	A3/9.2	A3/9.2	A3/9.2 3/	-	-
Secondary image	A3/9.3	A3/9.3	A3/9.3	A3/9.3	A3/9.3	A3/9.3	A3/9.3	A3/9.3 3/	-	-
Resistance to temperature changes	-	A3/8	-	A3/8	-	A3/8	A3/8	A3/8 2/	A3/8 2/	A3/8
Fire resistance	-	A3/10	-	A3/10	-	A3/10	A3/10	A3/10 2/	A3/10 2/	A3/10
Resistance to chemicals	-	A3/11	-	A3/11	-	A3/11	A3/11	A3/11 2/	A3/11 2/	A3/11

(1) Furthermore this test shall be carried out on double-glazed units pursuant to Annex 12 Paragraph 3 (A12/3).

(2) If coated on the inner side with plastics material.

(3) This test shall only be carried out on uniformly-toughened glass-panes to be used as windscreens of slow-moving vehicles which, by construction, cannot exceed 40 km/h.

Note: A reference such as A4/3 in the table indicates the Annex (4) and Paragraph (3) of that Annex, where the relevant test is described and the acceptance requirements are specified.

6.2.1.2. Plastic glazing materials shall be subjected to the tests listed in the following table.

Test	Plastics Other Than Windscreens				
	Rigid Plastics		Double Glazing		Flexible Plastics
	Motorised Vehicles	Trailers and Unoccupied Vehicles	Motorised Vehicles	Trailers and Unoccupied Vehicles	
Flexibility	A3/12	A3/12	A3/12	A3/12	A3/12
227 g ball	A13/5	A13/5	A15/5	A15/5	A14/4
Headform ⁽¹⁾	A13/4	-	A15/4	-	-
Light transmission ⁽²⁾	A3/9.1	-	A3/9.1	-	A3/9.1
Fire Resistance	A3/10	A3/10	A3/10	A3/10	A3/10
Chemical Resistance	A3/11	A3/11	A3/11	A3/11	A3/11
Abrasion	A13/6.1	-	A15/6.1	-	-
Weathering	A13/6.2	A13/6.2	A15/6.2	A15/6.2	A14/5
Humidity	A13/6.4	A13/6.4	A15/6.4	A15/6.4	-
Cross-Cut ⁽²⁾	A3/13	-	A3/13	-	-

(1) Test requirements are dependant on the location of the glazing within the vehicle.

(2) Applies only if the glazing is to be used in a location requisite for driving visibility.

ANNEX 1

WINDSCREEN DESIGN PARAMETERS

For each windscreen the following particulars shall be available:

- Vehicle manufacturer
- Type of vehicle
- Vehicle category
- Developed area (F)
- Height of segment (h)
- Curvature (r)
- Installation angle (α)
- Seat-back angle (β)
- R-point coordinates (A, B, C) relative to the centre of the upper edge of the windscreen.

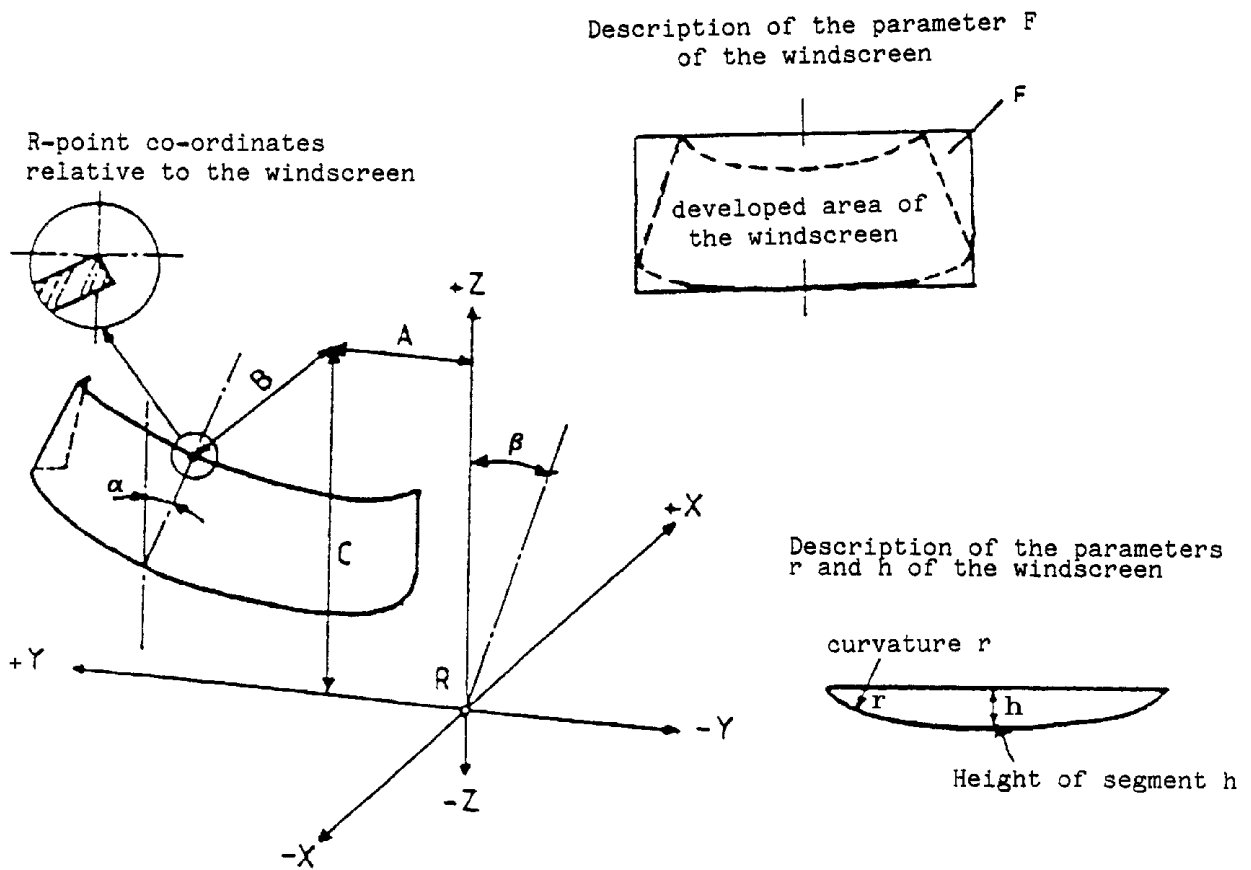

ANNEX 2

IDENTIFICATION MARKS FOR SAFETY GLAZING MATERIALS

The following additional symbols shall be included in the marking:

1. In the case of a windscreen:

- I. for toughened glass (I/P if faced) ⁽¹⁾
- II. for ordinary laminated glass (II/P if faced) ⁽¹⁾
- III. for treated laminated glass (III/P if faced) ⁽¹⁾
- IV. for glass-plastics glazing.

2. For glazing other than windscreens:

- V. In the case of a glazing other than a windscreen covered by the provisions of Annex 3, Paragraph 9.1.4.2.
- VI. In the case of a double-glazed unit.
- VII. In the case of uniformly-toughened glass panes which can be used as windscreens for slow-moving vehicles which, by construction, cannot exceed 40 km/h.
- VIII. In the case of rigid plastic glazing. In addition the appropriate application will be signified by:
 - /A for panes like partitions, separating and side windows
 - /B in locations where there is little or no chance of head impact
- IX. in the case of flexible-plastic glazing
- X. in the case of a rigid plastic double-glazed unit

⁽¹⁾ As defined in Paragraph 2.3.

ANNEX 3

GENERAL TEST CONDITIONS

1. FRAGMENTATION TEST

- 1.1. The glass pane to be tested shall not be rigidly secured; it may however be fastened on an identical glass pane by means of adhesive tape applied all round the edge.
- 1.2. To obtain fragmentation, a hammer of about 75 g or some other appliance giving equivalent results shall be used. The radius of curvature of the point shall be $0,2 \pm 0,05$ mm.
- 1.3. The test shall be carried out at the prescribed point of impact within 3 minutes after breaking.

2. BALL-IMPACT TESTS

2.1. 227 g Ball Test

2.1.1. Apparatus

- 2.1.1.1. Hardened-steel ball with a mass of 227 ± 2 g and a diameter of approximately 38 mm.
- 2.1.1.2. Means for dropping the ball freely from a height to be specified, or a means for giving the ball a velocity equivalent to that obtained by the free fall. When a device to project the ball is used, the tolerance on velocity shall be $\pm 1\%$ of the velocity equivalent to that obtained by the free fall.
- 2.1.1.3. Supporting fixture, such as that shown in Figure 1, composed of steel frames, with machined borders 15 mm wide, fitting one over the other and faced with rubber gaskets about 3 mm thick and 15 mm wide and of hardness 50 IRHD.

The lower frame rests on a steel box about 150 mm high. The test piece is held in place by the upper frame, the mass of which is about 3 kg. The supporting frame is welded onto a sheet of steel about 12 mm thick resting on the floor with an interposed sheet of rubber about 3 mm thick and of hardness 50 IRHD.

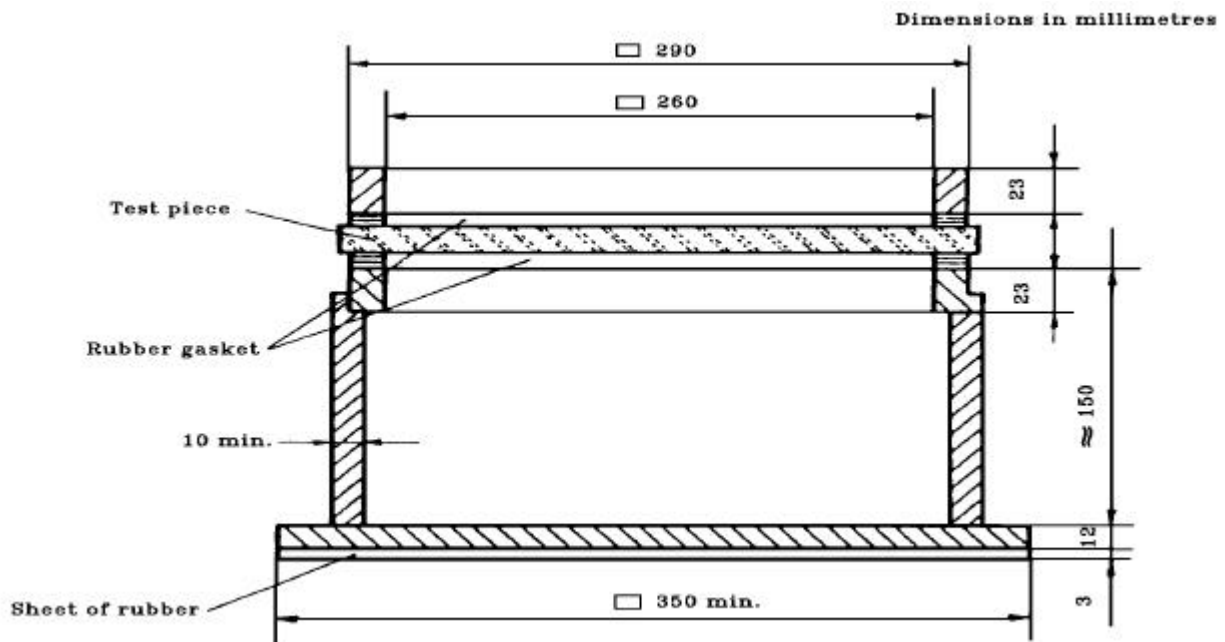

Figure 1

Support for Ball Tests

2.1.2. *Test conditions*

Temperature:	$20 \pm 5^{\circ}\text{C}$;
Pressure:	860 to 1060 mbar;
Relative humidity:	$60 \pm 20\%$

2.1.3. *Test piece*

The test piece shall be a flat square of side $300 \begin{matrix} +10 \\ -0 \end{matrix}$ mm or shall be cut from the flattest part of a windscreen or other curved pane of safety glazing.

Alternatively a curved pane of safety glazing may be tested. In this case care shall be taken to ensure adequate contact between the safety glazing and the support.

If finished products are used, they may be supported on a rigid support fixture, corresponding to the shape of the finished products, constructed to support the part in a position so that the 227 g hardened-steel ball will impact the external surface of the finished products. The support fixture shall have a peripheral support ledge about 15 mm wide covered with rubber of hardness 50 IRHD about 3 mm thick and shall rest on a sheet of the same material. The point of impact shall be the geometric centre ± 50 mm of the finished products.

2.1.4. *Procedure*

Condition the test piece at the specified temperature for at least four hours immediately preceding the test.

Place the test piece in the fixture (Paragraph 2.1.2.3.). The plane of the test piece shall be perpendicular, within 3° , to the incident direction of the ball.

In the case of flexible plastic glazing the test piece shall be clamped to the support.

The point of impact shall be within 25 mm of the geometric centre of the test piece for a drop height less than or equal to 6 m, and within 50 mm of the centre of the test piece for a drop height greater than 6 m. The ball shall strike that face of the test piece which represents the outside face of the safety-glazing pane when mounted on the vehicle. The ball shall be allowed to make only one impact.

2.2. **2 260 g Ball Test**

2.2.1. *Apparatus*

2.2.1.1. Hardened-steel ball with a mass of $2\ 260 \pm 20$ g and a diameter of approximately 82 mm.

2.2.1.2. Means for dropping the ball freely from a height to be specified, or means for giving the ball a velocity equivalent to that obtained by the free fall. When a device to project the ball is used, the tolerance on velocity shall be $\pm 1\%$ of the velocity equivalent to that obtained by the free fall.

2.2.1.3. The supporting fixture shall be as shown in Figure 1 and identical with that described in Paragraph 2.1.1.3.

2.2.2. *Test conditions*

Temperature:	$20^{\circ} \pm 5^{\circ}\text{C}$;
Pressure:	860 to 1060 mbar;

Relative humidity: $60 \pm 20\%$

2.2.3. *Test piece*

The test piece shall be a flat square of side 300 ± 10 - 0 mm or shall be cut out from the flattest part of a windscreen or other curved pane of safety glazing.
Alternatively, the whole windscreen or other curved pane of safety glazing may be tested. In this case care shall be taken to ensure adequate contact between the safety glazing pane and the support.

2.2.4. *Procedure*

Condition the test piece at the specified temperature for at least four hours immediately preceding the test.

Place the test piece in the fixture (Paragraph 2.1.1.3.). The plane of the test piece shall be perpendicular, within 3°, to the incident direction of the ball.

In the case of glass-plastics glazing the test piece shall be clamped to the support.

The point of impact shall be within 25 mm of the geometric centre of the test piece.

The ball shall strike that face of the test piece which represents the inward face of the safety-glass pane when the latter is mounted on the vehicle.

The ball shall be allowed to make only one impact.

3. HEADFORM TESTS

3.1. Headform Test Without Deceleration Measurement

3.1.1. Apparatus

Headform weight with a spherical or semi-spherical headform made of laminated hardwood covered with replaceable felt and with or without a cross-beam made of wood. There is a neck-shaped intermediate piece between the spherical part and the cross-beam and a mounting rod on the other side of the cross-beam.

The dimensions shall be in accordance with Figure 2.

The total mass of the apparatus shall be $10 \pm 0,2$ kg.

3.1.2. Means for dropping the headform weight freely from a height to be specified, or means for giving the weight a velocity equivalent to that obtained by the free fall.

When a device to project the headform weight is used, the tolerance on velocity shall be $\pm 1\%$ of the velocity equivalent to that obtained by the free fall.

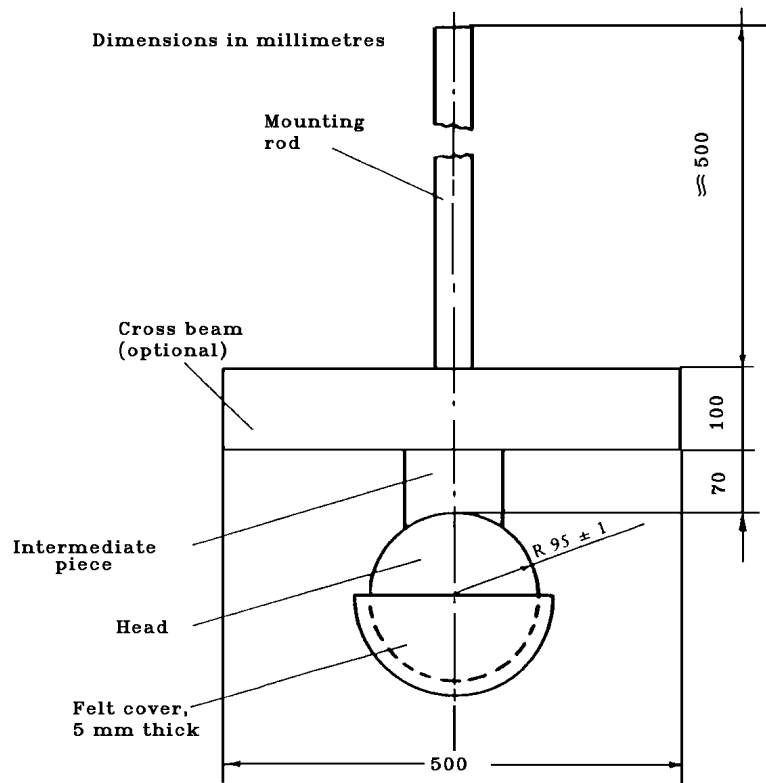

Figure 2

Headform Weight

3.1.3. Supporting fixture, as shown in Figure 3, for testing flat test pieces. The fixture is composed of two steel frames, with machined borders 50 mm wide, fitting one over the other and faced with rubber gaskets about 3 mm thick and 15 ± 1 mm wide and of hardness 70 IRHD.

The upper frame is held pressed against the lower frame by at least eight bolts.

3.1.4. **Test conditions**

Temperature: $20 \pm 5^\circ\text{C}$;

Pressure: 860 to 1060 mbar;

Relative humidity: $60 \pm 20\%$

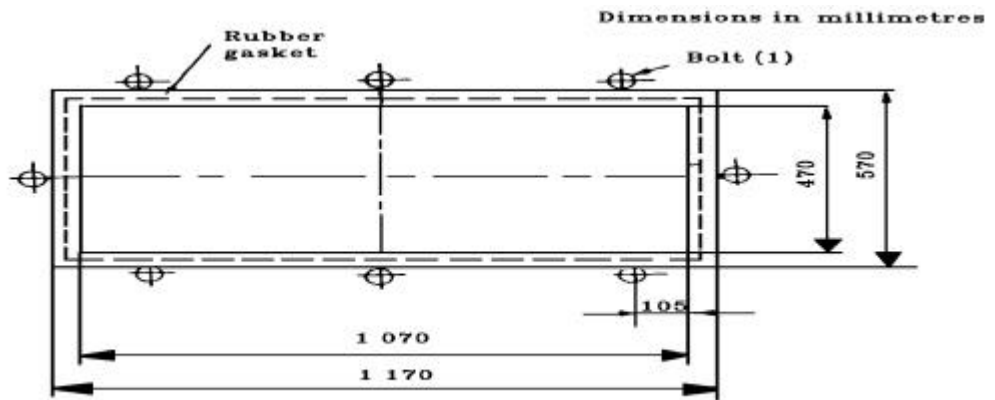

Figure 3

Support for headform tests

3.1.5. **Procedure**

3.1.5.1. *Test on a flat test piece*

The flat test piece, having a length of 1 100 ⁺⁵ -2 mm and a width of 500 ⁺⁵ -2 mm, shall be kept at a constant temperature of 20 ± 5°C for at least four hours immediately preceding the test.

Fix the test piece in the supporting frames (Paragraph 3.1.3.); the torque on the bolts shall ensure that the movement of the test piece during the test will not exceed 2 mm. The plane of the test piece shall be substantially perpendicular to the incident direction of the weight. The weight shall strike the test piece within 40 mm of its geometric centre on that face which represents the inward face of the safety-glass pane when the latter is mounted on the vehicle, and shall be allowed to make only one impact.

The impact surface of the felt cover shall be replaced after 12 tests.

3.1.5.2. *Tests on a complete windscreen (used only for a drop height of less than or equal to 1,5 m).*

Place the windscreen freely on a support with an interposed strip of rubber of hardness 70 IRHD and thickness about 3 mm, the width of contact over the whole perimeter being about 15 mm.

The support shall consist of a rigid piece corresponding to the shape of the windscreen so that the headform weight strikes the internal surface. If necessary the windscreen shall be clamped to the support.

The support shall rest on a rigid stand with an interposed sheet of rubber of hardness 70 IRHD and thickness about 3 mm. The surface of the windscreen shall be substantially perpendicular to the incident direction of the headform weight.

The headform weight shall strike the windscreen at a point within 40 mm of its geometric centre on that face which represents the inward face of the safety-glass pane when the latter is mounted on the vehicle, and shall be allowed to make only one impact.

The impact surface of the felt cover shall be replaced after 12 tests.

(1) The minimum recommended torque for M 20 is 30 Nm.

3.2. Headform Test With Deceleration Measurement

3.2.1. Apparatus

In the case of headform tests with simultaneous determination of HIC-values the drop body is the phantom head as in Figure 2.1. The total mass of the phantom head should be 10.0 + 0.2/- 0.0 kg.

In the middle of the base plate (24) the triaxial mounting block (26) is mounted in the centre of gravity to receive the acceleration gauges (27). The acceleration gauges should be arranged vertically to each other.

The basin (18) and cover (19) situated under the base plate (24) share, to a great extent, the elastic properties of the human skull. The elastic properties of the phantom head on impact are determined by the hardness and the thickness of the intermediate ring (13) and the basin.

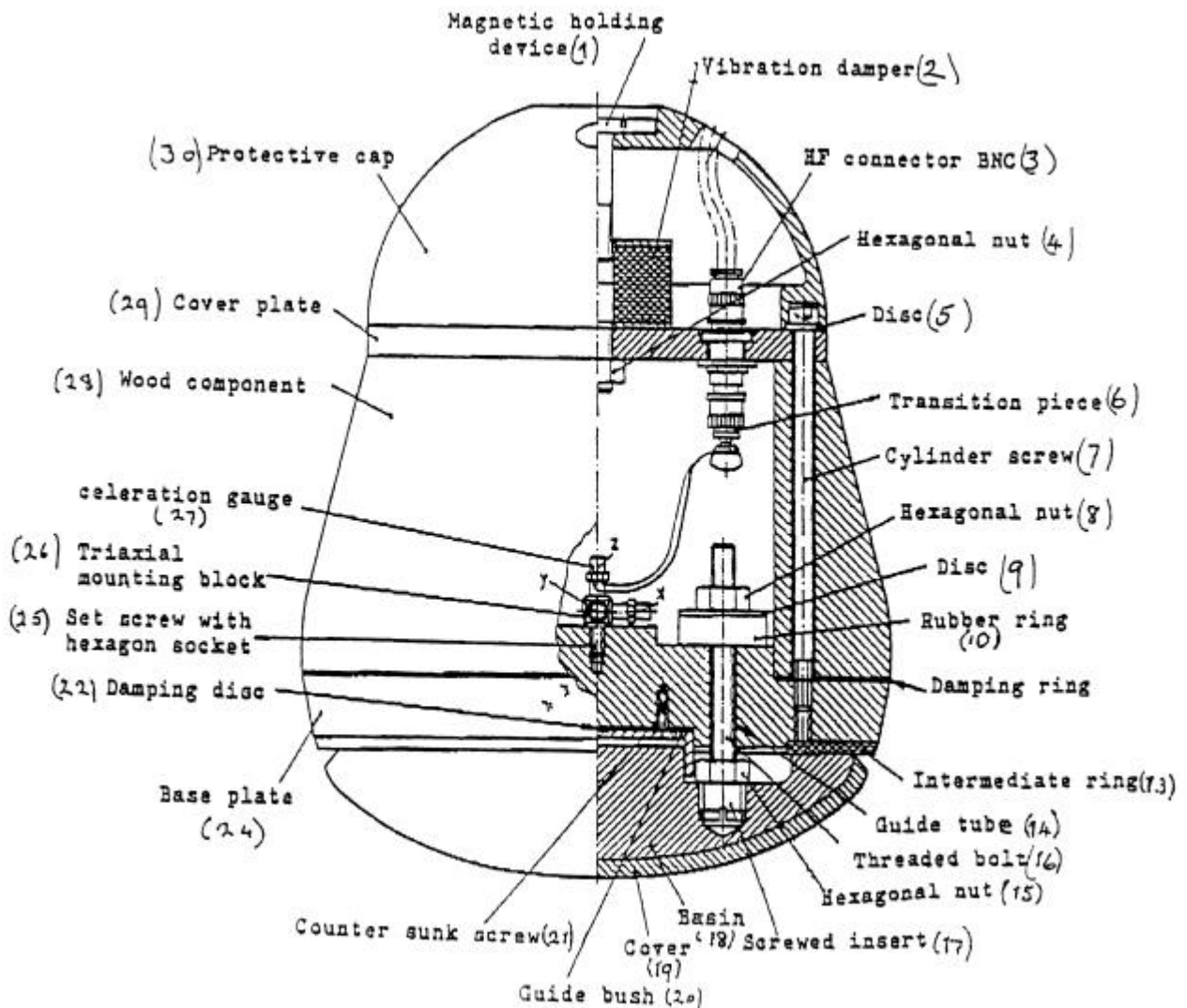

Figure 2.1
10-kg-Headform

List of pieces for the 10 kg headform concerning figure 2.1

Position No.	Number of pieces	Standard notation	Material	Remarks
1	1	Magnetic holding device	Steel DIN 17100	
2	1	Vibration damper	Rubber/steel	Diameter: 50 mm Thickness: 30 mm Worm: M10
3	4	HF connector BNC		
4	1	Hexagonal nut DIN 985		
5	6	Disc DIN 125		
6	3	Transition piece		
7	6	Cylinder screw DIN 912		
8	3	Hexagonal nut		
9	3	Disc	Steel DIN 17100	Diameter of hole: 8 mm Outer diameter: 35 mm Thickness: 1,5 mm
10	3	Rubber ring	Rubber, hardness 60 IRHD	Diameter of hole: 8 mm Outer diameter: 30 mm Thickness: 10 mm
11	1	Damping ring	Packing with paper	Diameter of hole: 120 mm Outer diameter: 199 mm Thickness: 0,5 mm
13	1	Intermediate ring	Butadien-rubber, hardness IRHD about 80	Diameter of hole: 129 mm Outer diameter: 192 mm Thickness: about 4 mm
14	3	Guide tube	Polytetrafluorethen (PTFE)	Inner diameter: 8 mm Outer diameter: 10 mm Length: 40 mm
15	3	Hexagonal nut		
16	3	Threaded bolt DIN 976		
17	3	Screwed insert	Cast alloy DIN 1709-GD-CuZn37Pb	
18	1	Basin	Polyamid 12	
19	1	Cover	Butadien-rubber	Thickness: 6 mm

				Rib on one side
20	1	Guide bush	Steel DIN 17100	
21	4	Counter sunk screw		
22	1	Damping disc	Packing with paper	Diameter: 65 mm Thickness: 0,5 mm
24	1	Base plate	Steel DIN 17100	
25	1	Set screw with hexagon socket	Class of strength 45 H	
26	1	Triaxial mounting block		
27	3	Acceleration gauge		
28	1	Wood component	Hornbeam, glued in layers	
29	1	Cover plate	Alloy (AlMg5)	
30	1	Protective cap	Polyamid 12	

A headform giving an equivalent result may be used. (2)

(2) The headform defined in US 40 CFR Part 572.

3.2.2. Adjustment and Calibration

To perform the headform test the phantom head is fixed to the cross arm of the guide system (Figure 2.2) and moved to the required drop height by means of a lifting device. During the headform test the cross arm with the

phantom head is released. After passing the height adjustable light barrier the phantom head is released from the cross arm, the cross arm's fall is dampened and the phantom head falls onto the sample.

No impulse may be given to the phantom head by the drop appliance or by the measuring cable, so that it is accelerated only by gravity and falls vertically.

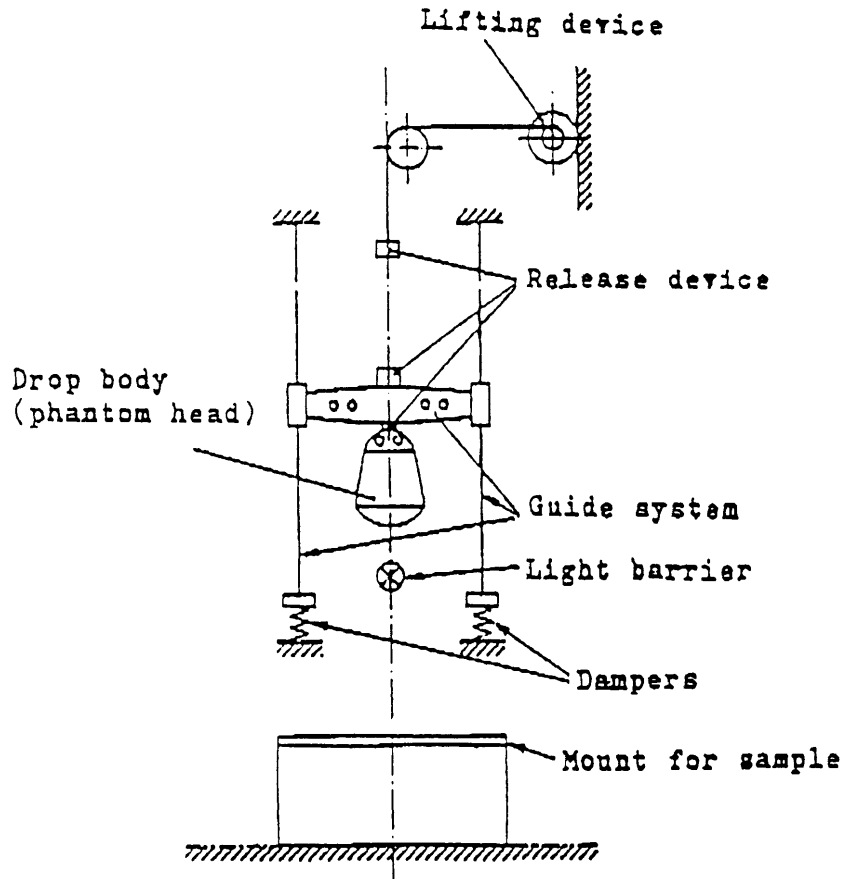

Figure 2.2

**Test apparatus for the headform experiment
with deceleration measurement**

3.2.2.1. Measuring device which allows to determine HIC-values with the headform described under 3.2.1.

3.2.2.2. Equipment to calibrate the phantom head.

The drop appliance must allow drop heights between 50 mm and 254 mm to be adjusted exactly to within 1 mm. A guide system is not necessary for these small drop heights.

A steel impact plate which is made of steel is 600 mm x 600 mm in size and at least 50 mm thick. The impact surface must be polished:

surface roughness $R_{max} = 1 \mu\text{m}$, flatness tolerance $t = 0.05 \text{ mm}$.

3.2.2.3. Calibration and adjustment of the phantom head

Before each test series and no later than each 50 tests within a series, the phantom head must be calibrated and adjusted if necessary.

The impact plate must be clean and dry and during the test must lie non-positively on a concrete base.

The phantom head is allowed to hit the impact plate vertically. The drop heights (measured from the lowest point of the phantom head to the surface of the impact plate) are 50, 100, 150 and 254 mm. The deceleration curves should be recorded.

The greatest deceleration a_z from the various drop heights on the z-axis must lie within the limits given in the table:

Drop height mm	Greatest deceleration a_z as a multiple of acceleration due to gravity g
50	64 ± 5
100	107 ± 5
150	150 ± 7
254	222 ± 12

The deceleration curves should be based on a unimodal vibration. The deceleration curve of the drop height of 254 mm must run at least 1.2 ms and at most 1.5 ms over 100 g.

If the requirements given in 3.2.2.3. are not met, the elastic properties of the phantom head must be adjusted varying the thickness of the intermediate ring (13) in the base plate (24). Corrections can be carried out by adjusting the three self-locking hexagonal nuts (8) on the threaded bolts (16) with which the basin (18) is fixed to the base plate (24). The rubber rings (10) under the hexagon nuts (8) should not be brittle or cracked.

The cover (19) of the impact surface and the intermediate ring (13) should always be replaced immediately if damaged, especially when the phantom head can no longer be adjusted.

3.2.3. Supporting fixture for testing flat test pieces is as described in 3.1.3.

3.2.4. Test conditions are specified in 3.1.4.

3.2.5. Tests on complete panes (used for a drop height between 1.5 m and 3 m). Place the pane freely on a support with an interposed strip of rubber of hardness 70 IRHD and thickness of about 3 mm.

pane
shall
of
The pane shall be clamped to the supporting structure by means of appropriate devices. The surface of the shall be substantially perpendicular to the incident direction of the headform weight. The headform weight strike the pane at a point within 40 mm of its geometric centre on that face which represents the inward face of the plastic pane when the latter is mounted on the vehicle, and shall be allowed to make only one impact.

be
After the headform test, it should be checked whether a glazing edge has moved more than 2 mm in the mount and whether the requirement for the point of impact was met. The acceleration components a_x and a_y should be smaller for vertical impact than $0.1 a_z$.

3.2.6. Evaluation

The deceleration curves should be evaluated as follows:

deceleration
The resulting deceleration $a_{res}(t)$ in the centre of gravity according to equation (1) from the measured curves $a_x(t)$, $a_y(t)$ and $a_z(t)$ is to be compounded as multiples of the acceleration due to gravity g

$$(1) \quad a_{res}(t) = (a_x^2(t) + a_y^2(t) + a_z^2(t))^{1/2}$$

brain-
injuries using the following equation (2):
The time for which a deceleration of 80 g with a_{res} is continually exceeded and the greatest deceleration of a_{res} should be determined. The HIC-value should be calculated as a measurement of the danger of blunt skull-

$$(2) \quad HIC = (t_2 - t_1)^{-1.5} \left(\int_{t_1}^{t_2} a_{res}(t) dt \right)^{2.5}$$

The integral limits t_1 and t_2 should be selected in such a way that the integral takes a maximal value.

4. TEST OF RESISTANCE TO ABRASION

4.1. Apparatus

4.1.1. Abrading instrument, ⁽³⁾ shown diagrammatically in Figure 4 and consisting of:—

A horizontal turntable, with centre clamp, which revolves counter-clockwise at 65 to 75 rev/min;

Two weighted parallel arms each carrying a special abrasive wheel freely rotating on a ball-bearing horizontal spindle; each wheel rests on the test specimen under the pressure exerted by a mass of 500 g.

The turntable of the abrading instrument shall rotate regularly, substantially in one plane (the deviation from this plane shall not be greater than $\pm 0,05$ mm at a distance of 1,6 mm from the turntable periphery).

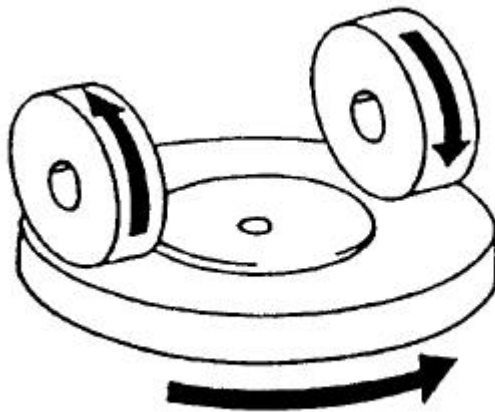

Figure 4

Diagram of Abrading Instrument

The wheels shall be mounted in such a way that when they are in contact with the rotating test piece they rotate in opposite directions so as to exert, twice during each rotation of the test piece, a compressive and abrasive action along curved lines over an annular area of about 30 cm².

4.1.2. Abrasive wheels ⁽⁴⁾, each 45 to 50 mm in diameter and 12,5 mm thick, composed of a special finely-screened abrasive embedded in a medium hard rubber. The wheels shall have a hardness of 72 ± 5 IRHD, as measured at four points equally spaced on the centreline of the abrading surface, the pressure being applied vertically along a diameter of the wheel and the readings being taken 10 seconds after full application of the pressure.

The abrasive wheels shall be prepared for use by very slow rotation against a sheet of flat glass to ensure that their surface is completely even.

4.1.3. Light source consisting of an incandescent lamp with its filament contained within a parallelepiped measuring 1,5 mm x 1,5 mm x 3 mm. The voltage at the lamp filament shall be such that the colour temperature is 2856 ± 50 K. This voltage shall be stabilised within $\pm 1/1000$. The instrument used to check the voltage shall be of appropriate accuracy.

⁽³⁾ A suitable abrading instrument is supplied by Teledyne Taber (United States of America).

⁽⁴⁾ Suitable abrasive wheels may be obtained from Teledyne taber (United States of America).

4.1.4. Optical system consisting of a lens with a focal length f of at least 500 mm and corrected for chromatic aberrations. The full aperture of the lens shall not exceed $f/20$. The distance between the lens and the light source shall be adjusted in order to obtain a light beam which is substantially parallel.

A diaphragm shall be inserted to limit the diameter of the light beam to 7 ± 1 mm. This diaphragm shall be situated at a distance of 100 ± 50 mm from the lens on the side remote from the light source.

4.1.5. Equipment for measuring scattered light (see Figure 5), consisting of a photoelectric cell with an integrating sphere 200 to 250 mm in diameter. The sphere shall be equipped with entrance and exit ports for the light. The entrance port shall be circular and have a diameter at least twice that of the light beam. The exit port of the sphere shall be provided with either a light trap or a reflectance standard, according to the procedure described in Paragraph 4.4.3. below. The light trap shall absorb all the light when no test piece is inserted in the light beam.

The axis of the light beam shall pass through the centre of the entrance and exit ports. The diameter b of the light-exit port shall be equal to $2 a \cdot \tan 4^\circ$, where a is the diameter of the sphere. The photoelectric cell shall be mounted in such a way that it cannot be reached by light coming directly from the entrance port or from the reflectance standard.

The surfaces of the interior of the integrating sphere and the reflectance standard shall be of substantially equal reflectance and shall be matt and non-selective.

The output of the photoelectric cell shall be linear within $\pm 2\%$ over the range of luminous intensities used. The design of the instrument shall be such that there is no galvanometer deflection when the sphere is dark.

The whole apparatus shall be checked at regular intervals by means of calibration standards of defined haze.

If haze measurements are made using equipment or methods differing from those defined above, the results shall be corrected, if necessary, to bring them into agreement with those obtained by the apparatus described above.

4.2. **Test conditions**

Temperature: $20 \pm 5^\circ\text{C}$;

Pressure: 860 to 1060 mbar;

Relative humidity: $60 \pm 20\%$

4.3. **Test pieces**

The three test pieces shall be flat squares of side 100 mm having both surfaces substantially plane and parallel and having a fixing hole $6,4 \pm 0,2$ mm in diameter drilled in the centre, if necessary.

- 0

4.4. Procedure

The abrasion test shall be carried out on that surface of the test piece which represents the outside face of the laminated-glass pane when the latter is mounted on the vehicle and also on the inner face if of plastics material.

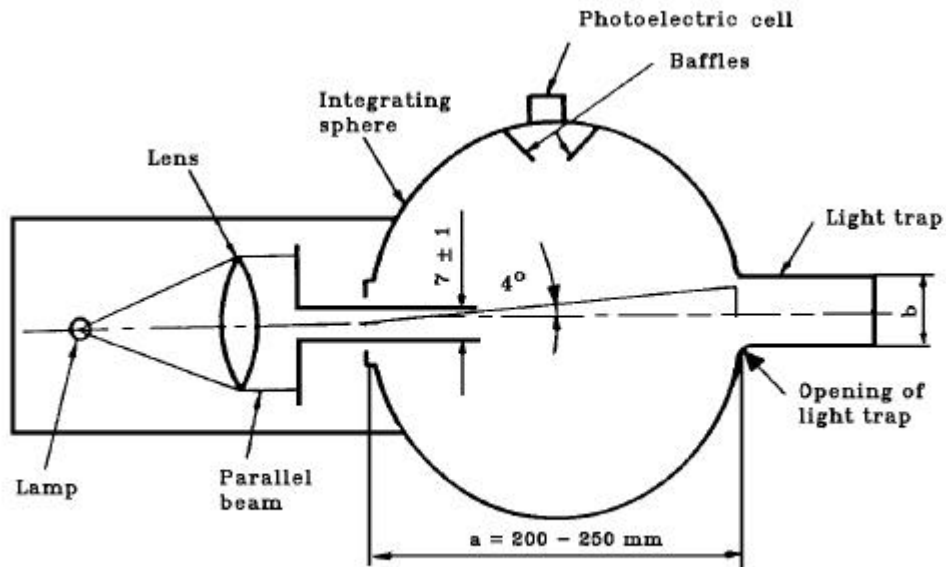

Figure 5

Hazemeter

4.4.1. Immediately before and after the abrasion, clean the test pieces in the following manner:

- a) wipe with a linen cloth under clean running water,
- b) rinse with distilled or demineralised water,
- c) blow dry with oxygen or nitrogen,
- d) remove possible traces of water by dabbing softly with a damp linen cloth. If necessary, dry by pressing lightly between two linen cloths.

Any treatment with ultrasonic equipment shall be avoided. After cleaning, the test pieces shall be handled only by their edges and shall be stored to prevent damage to, or contamination of, their surfaces.

4.4.2. Condition the test pieces for a minimum time of 48 hours at $23 \pm 5^\circ\text{C}$ and $50 \pm 20\%$ relative humidity.

4.4.3. Immediately place the test piece against the entrance port of the integrating sphere. The angle between the normal (perpendicular) to the surface of the test piece and the axis of the light beam shall not exceed 8°.

Take four readings as indicated in the following table:—

Reading	With test piece	With light trap	With reflectance standard	Quality represented
T ₁	No	No	Yes	Incident light
T ₂	Yes	No	Yes	Total light transmitted by test-piece
T ₃	No	Yes	No	Light scattered by instrument
T ₄	Yes	Yes	No	Light scattered by instrument and test piece

Repeat readings for T₁, T₂, T₃ and T₄ with other specified positions of the test piece to determine uniformity.

Calculate the total transmittance $T_t = T_2/T_1$.

Calculate the diffuse transmittance T_d as follows: -

$$T_d = \frac{T_4 - T_3(T_2/T_1)}{T_1}$$

Calculate the percentage haze, or light, or both, scattered, as follows: -

$$\text{Haze, or light or both, scattered} = \frac{T_d}{T_t} \times 100\%$$

Measure the initial haze of the test piece at a minimum of four equally-spaced points in the unabraded area in accordance with the formula above. Average the results for each test piece. In lieu of the four measurements, an average value may be obtained by rotating the piece uniformly at 3 rev/sec or more.

For each type of safety glazing, carry out three tests with the same load. Use the haze as a measure of the subsurface abrasion, after the test piece has been subjected to the abrasion test.

Measure the light scattered by the abraded track at a minimum of four equally-spaced points along the track in accordance with the formula above. Average the results for each test piece. In lieu of the four measurements, an average value may be obtained by rotating the piece uniformly at 3 rev/sec or more.

4.5. The abrasion test will be carried out only at the discretion of the laboratory conducting the test with due regard to the information already at its disposal.

Except for glass-plastics materials, changes in the interlayer or material thickness will not normally necessitate further testing.

.6. Indices of difficulty of the secondary characteristics

No secondary characteristics are involved.

5. TEST OF RESISTANCE TO HIGH TEMPERATURE

5.1. Procedure

Heat to 100°C three samples, three finished parts or three square test pieces of at least 300 mm x 300 mm which have been cut by the laboratory from three windscreens or three glass panes other than windscreens as the case may be, one edge of which corresponds to the upper edge of the glazing.

Maintain this temperature for a period of two hours, then allow the samples or test pieces to cool to room temperature.

If the safety-glass pane has both external surfaces of inorganic material, the test may be carried out by immersing the sample vertically in boiling water for the specified period of time, care being taken to avoid undue thermal shock.

If samples are cut from windscreens, one edge of each such sample shall be part of an edge of the windscreen.

5.2. Indices of difficulty of the secondary characteristics

	<u>Colourless</u>	<u>Tinted</u>
Colouring of the interlayer:	1	2

The other secondary characteristics are not involved.

5.3. **Interpretation of results**

5.3.1. The test for resistance to high temperature shall be considered to give a positive result if bubbles or other defects are not formed more than 15 mm from an uncut edge or 25 mm from a cut edge of the test piece or sample or more than 10 mm away of any cracks which may occur during the test.

5.3.2. A set of test pieces or samples shall be considered satisfactory from the point of view of the test for resistance to high temperature if either of the following conditions is fulfilled:—

5.3.2.1. All the tests give a satisfactory result; or

5.3.2.2. One test having given an unsatisfactory result, a further series of tests carried out on a new set of test pieces or samples gives satisfactory results.

6. RESISTANCE-TO-RADIATION TEST

6.1. **Test method**

6.1.1. *Apparatus*

6.1.1.1. Radiation source consisting of a medium-pressure mercury-vapour arc lamp with a tubular quartz bulb of ozone-free type; the bulb axis shall be vertical. The nominal dimensions of the lamp shall be 360 mm in length by 9,5 mm in diameter. The arc length shall be 300 ± 4 mm. The lamp shall be operated at 750 ± 50 W.

Any other source of radiation which produces the same effect as the lamp specified above may be used. To check that the effects of another source are the same, a comparison shall be made by measuring the amount of energy emitted within a wavelength range of 300 to 450 nanometres, all other wavelengths being removed by the use of suitable filters.

In the case of safety-glass panes for which there is no satisfactory correlation between this test and the conditions of use it will be necessary to review the test conditions.

6.1.1.2. Power-supply transformer and capacitor capable of supplying to the lamp (Paragraph 6.1.1.1.) a starting peak voltage of 1 100 V minimum and an operating voltage of 500 ± 50 V.

6.1.1.3. Device for mounting and rotating the test pieces at 1 to 5 rev/min about the centrally-located radiation source in order to ensure even exposure.

6.1.2. *Test pieces*

The size of the test pieces shall be 76 mm x 300 mm.

6.1.2.2. The test pieces shall be cut by the laboratory from the upper part of the glass panes in such a way that:

In the case of glass panes other than windscreens, the upper edge of the test piece coincides with the upper edge of the glass pane,

In the case of windscreens, the upper edge of the test piece coincides with the upper limit of the zone in which regular transmittance shall be measured, determined in accordance with Paragraph 9.1.2.2. of this Annex.

6.1.3. *Procedure*

Check the regular light transmittance, determined according to Paragraphs 9.1.1. to 9.1.2. of this Annex, of three test pieces before exposure. Protect a portion of each test piece from the radiation, and then place the test pieces in the test apparatus 230 mm from and parallel lengthwise to the lamp axis. Maintain the temperature of the test pieces at $45 \pm 5^\circ\text{C}$ throughout the test.

That face of each test specimen which would constitute a glazed exterior part of the vehicle shall face the lamp. For the type of lamp specified in Paragraph 6.1.1.1. the exposure time shall be 100 hours.

After exposure, measure the regular light transmittance again in the exposed area of each test piece.

6.1.4. Each test piece or sample (total number 3 pieces) shall be subjected, in accordance with the procedure above, to radiation such that the radiation on each point of the test piece or sample produces on the interlayer used the same effect as that which would be produced by solar radiation of $1\,400\text{ W/m}^2$ for 100 hours.

6.2. **Indices of difficulty of the secondary characteristics**

	<u>Colourless</u>	<u>Tinted</u>
Colouring of glass	2	1
Colouring of interlayer	1	2

The other secondary characteristics are not involved.

6.3. **Interpretation of results**

6.3.1. The test for resistance to radiation shall be deemed to have given a positive result if the following conditions are fulfilled:—

6.3.1.1. The total light transmittance when measured pursuant to Paragraphs 9.1.1. and 9.1.2. of this Annex does not fall below 95% of the original value before irradiation and in any event does not fall:

6.3.1.1.1. Below 70% in the case of vehicle glazings which are required to comply with the specifications regarding the driver's field of view in all directions;

6.3.1.2. The test piece or sample may however show a slight coloration after irradiation when examined against a white background, but no other defect may be apparent.

6.3.2. A set of test pieces or samples shall be considered acceptable if all the tests give a satisfactory result.

6.4. Resistance to Simulated Weathering

6.4.1. Test Method

6.4.1.1. Apparatus

6.4.1.1.1. Long Arc Xenon Lamp

The exposure apparatus⁽⁵⁾ shall utilize a long arc xenon lamp as the source of irradiation, but other methods giving the required level of ultraviolet radiant exposure shall be allowed.

The long arc xenon lamp is advantageous in that it can, when correctly filtered and maintained, yield a spectrum most closely approximating that of natural sunlight. To this end, the quartz xenon burner tube shall be fitted with suitable borosilicate glass optical filter(s)⁽⁶⁾. The xenon lamps employed shall be operated, from a suitable 50 or 60 Hz power supply suitable reactance transformers and electrical equipment.

The exposure apparatus shall include equipment necessary for measuring and/or controlling the following:

- Irradiance
- Black standard temperature
- Water Spray
- Operating schedule or cycle

The exposure apparatus shall be made from inert materials which do not contaminate the water employed in the test.

Irradiance shall be measured at the test specimen surface and shall be controlled according to the recommendations of the exposure apparatus manufacturer.

Total ultraviolet⁽⁷⁾ radiant exposure (Joules per square metre) shall be measured or computed and shall be considered the primary measure of test specimen exposure.

6.4.1.2. Test Specimens

The dimensions of the test specimen shall normally be those specified in the appropriate test method for the property or properties to be measured after exposure.

The number of control and test specimens for each test condition or exposure stage shall be determined, in addition to those required for visual evaluations by the number required by the test methods.

6.4.1.3. Procedure

Measure, according to Paragraph 9.1 of this annex the luminous transmission of the test specimen(s) to be exposed. Measure, according to Paragraph 4 of this annex, the resistance to abrasion of the surface(s) of the control specimen(s). That face of each test specimen, which would represent the surface glazed to the exterior of the road vehicle, shall face the lamp. Other exposure conditions shall be as follows:

6.4.1.3.1. The irradiance shall not vary more than $\pm 10\%$ over the whole test specimen area.

6.4.1.3.2. At appropriate intervals, clean lamp filters by washing with detergent and water. Xenon arc filters shall be replaced according to the recommendations of the equipment manufacturer.

⁽⁶⁾ Such as Corning 7740 Pyrex or Heraeus Suprax

6.4.1.3.3. The temperature within the exposure apparatus during the dry portion of the cycle shall be controlled by circulation of sufficient air to maintain a constant black standard temperature.

In the Xenon arc exposure apparatus, this temperature shall be $70 \pm 3^{\circ}\text{C}$ as indicated by a Black Standard Thermometer or equivalent.

The black panel thermometer shall be mounted in the test specimen rack and readings shall be taken at the point where maximum heat is developed due to light exposure.

6.4.1.3.4. The relative humidity within the exposure apparatus shall be controlled at $50 \pm 5\%$ during the dry portions of the cycle.

6.4.1.3.5. The deionized water used in the spray cycle shall contain less than 1 ppm silicon dioxide solids and shall leave no permanent deposit or residue on the test specimens which would interfere with subsequent measurements.

6.4.1.3.6. The pH of the water shall be between 6.0 and 8.0, and the conductivity shall be less than 5 microsismens.

6.4.1.3.7. The temperature of the water in the line where it enters the exposure apparatus shall be the ambient water temperature.

6.4.1.3.8. The water shall strike the test specimens in the form of a fine spray in sufficient volume to wet the test specimens uniformly, immediately upon impact.

Water spray will be directed only against the test specimen surface facing the light source. No recirculation of the spray water or immersion of the test specimens in the water shall be permitted.

6.4.1.3.9. The test specimens shall be rotated about the arc in order to provide uniform distribution of the light. All positions in the exposure apparatus shall be filled with test specimens or surrogates to ensure that a uniform temperature distribution is maintained. Test specimens shall be held in frames with backs exposed to the cabinet environment. However, reflections from cabinet walls shall not be permitted to strike the back surface of specimens. If necessary, samples may be backed to block such reflections so long as free circulation of air at the specimen surface is not impeded.

6.4.1.3.10. The exposure apparatus shall be operated to provide continuous light and intermittent water spray in 2 h cycles. Each 2 h cycle shall be divided into periods during which the test specimens are exposed to light without water spray for 102 minutes and to light with water spray for 18 minutes.

6.4.1.4. Evaluation

After exposure, the test specimens may be cleaned, if necessary, by a practice recommended by their manufacturer to remove any residues present.

Evaluate the exposed test specimens visually with respect to the following properties.

- Bubbles
- Colour
- Haze
- Noticeable decomposition

Measure the luminous transmission of the exposed specimens.

6.4.1.5. Expression of Results

Report visual evaluations of exposed test specimens, comparing the appearance of each with that of the unexposed control.

The luminous transmittance measured must not differ from the original tests on unexposed samples by more than 5% and shall not fall below 70 % for vehicle glazing which is located in a position requisite for driving visibility.

7. RESISTANCE-TO-HUMIDITY TEST

7.1. Procedure

Keep three samples, three finished parts, or three square test pieces of at least 300 mm x 300 mm in a vertical position for two weeks in a closed container in which the temperature is maintained at $50 \pm 2^\circ\text{C}$ and the relative humidity at $95 \pm 4\%$.

In the case of rigid plastic glazings and rigid plastic double glazed units the number of samples shall be ten.

The test pieces shall be prepared in such a way that:

- at least one edge of the test pieces coincides with an original edge of the glass pane,
- if several test pieces are tested at the same time, adequate spacing shall be provided between them.

Precautions shall be taken to prevent condensate from the walls or ceiling of the test chamber from falling on the test pieces.

7.2. Indices of difficulty of the secondary characteristics

	<u>Colourless</u>	<u>Tinted</u>
Colouring of interlayer	1	2

The other secondary characteristics are not involved.

7.3. **Interpretation of results**

7.3.1. Safety glazing shall be deemed to be satisfactory from the point of view of resistance to humidity if no significant change is observed more than 10 mm from the uncut edges and more than 15 mm from the cut edges after ordinary and treated laminated glass panes have been maintained for two hours in the ambient atmosphere, and plastics-faced and glass-plastics panes have been maintained for 48 hours in the ambient atmosphere.

7.3.2. A set of test pieces or samples shall be considered acceptable if all the tests give a satisfactory result.

8. **TEST OF RESISTANCE TO TEMPERATURE CHANGES**

8.1. **Test method**

Two test pieces 300 x 300 mm shall be placed in an enclosure at a temperature of $-40^{\circ}\text{C} \pm 5^{\circ}\text{C}$ for a period of 6 hours; they shall then be placed in the open air at a temperature of $23^{\circ}\text{C} \pm 2^{\circ}\text{C}$ for one hour or until temperature equilibrium has been reached by the test pieces. These shall then be placed in circulating air at a temperature of $72^{\circ}\text{C} \pm 2^{\circ}\text{C}$ for 3 hours. After being placed again in the open air at $23^{\circ}\text{C} \pm 2^{\circ}\text{C}$ and cooled to that temperature, the test pieces shall be examined.

8.2. **Indices of difficulty of secondary characteristics**

	<u>Colourless</u>	<u>Tinted</u>
Colouring of the interlayer or of the plastics coating	1	2

The other secondary characteristics are not involved.

8.3. **Interpretation of results**

The test for resistance to temperature changes shall be considered to have given a satisfactory result if the test pieces do not show any evidence of cracking, clouding, separation of layers apparent deterioration.

9. **OPTICAL QUALITIES**

9.1. **Light transmission test**

9.1.1. *Apparatus*

9.1.1.1. Light source consisting of an incandescent lamp with its filament contained within a parallelepiped measuring 1,5 mm x 1,5 mm x 3 mm. The voltage at the lamp filament shall be such that the colour temperature is 2856 ± 50 K. This voltage shall be stabilised within $\pm 1/1000$. The instrument used to check the voltage shall be of appropriate accuracy.

9.1.1.2. Optical system consisting of a lens with a focal length f of at least 500 mm and corrected for chromatic aberrations. The full aperture of the lens shall not exceed $f/20$. The distance between the lens and the light source shall be adjusted in order to obtain a light beam which is substantially parallel.

A diaphragm shall be inserted to limit the diameter of the light beam to 7 ± 1 mm. This diaphragm shall be situated at a distance of 100 ± 50 mm from the lens on the side remote from the light source. The point of measurement shall be taken at the centre of the light beam.

9.1.1.3. Measuring equipment

The receiver shall have a relative spectral sensitivity in substantial agreement with the relative spectral luminous efficiency for the ICI⁽⁸⁾ standard photometric observer for photopic vision. The sensitive surface of the receiver shall be covered with a diffusing medium and shall have at least twice the cross-section of the light beam emitted by the optical system. If an integrating sphere is used, the aperture of the sphere shall have a cross-sectional area at least twice that of the parallel portion of the beam.

The linearity of the receiver and the associated indicating instrument shall be better than 2% of the effective part of the scale.

The receiver shall be centred on the axis of the light beam.

9.1.2. Procedure

The sensitivity of the measuring system shall be adjusted in such a way that the instrument indicating the response of the receiver indicates 100 divisions when the safety glazing material is not inserted in the light path. When no light is falling on the receiver, the instrument shall read zero.

Place the safety glazing material at a distance from the receiver equal to approximately five times the diameter of the receiver. Insert the safety glazing material between the diaphragm and the receiver and adjust its orientation in such a way that the angle of incidence of the light beam is equal to $0 \pm 5^\circ$. The regular transmittance shall be measured on the safety-glass pane, and for every point measured the number of divisions, n , shown on the indicating instrument, shall be read. The regular transmittance τ is equal to $n/100$.

9.1.2.1. In the case of windscreens, alternative test methods may be applied using either a test piece cut from the flattest part of a windscreen or a specially-prepared flat square with material and thickness characteristics identical to those of the actual windscreen, the measurements being taken normal (perpendicular) to the glass pane.

9.1.2.2. For the windscreens of [M₁ vehicles⁽⁹⁾] the test shall be carried out in the Zone B specified in Annex 17 to this Regulation. For all other vehicles the test shall be carried out in Zone I defined in Paragraph 9.2.5.2.3. of this Annex.

However, for agricultural and forestry tractors and for construction-site vehicles for which it is not possible to determine zone I, the test shall be carried out in Zone I' as defined in Paragraph 9.2.5.3. of this Annex.

9.1.3. Indices of difficulty of the secondary characteristics

	<u>Colourless</u>	<u>Tinted</u>
Colouring of the glass	1	2
Colouring of the interlayer (in the case of laminated windscreens)	1	2
	<u>Not Included</u>	<u>Included</u>
Shade and/or obscuration bands	1	2

The other secondary characteristics are not involved.

9.1.4. *Interpretation of results*

9.1.4.1. The regular transmittance measured according to Paragraph 9.1.2. on three samples or test pieces shall not be less than 70 % for all places essential for driver vision.

9.1.4.2. In the case of safety glazing in places not essential for the driver vision (e.g. sun roofs), the regular light transmission of the safety glazing measured on three samples or test pieces may be less than 70%. Safety glazing with a regular light transmittance less than 70% shall be appropriately marked.

9.2. **Optical distortion test**

9.2.1. *Scope*

The method specified is a projection method which permits evaluation of the optical distortion of a safety-glass pane.

9.2.1.1. Definitions

9.2.1.1.1. Optical deviation: The angle between the true and the apparent direction of a point viewed through the safety-glass pane, the magnitude of the angle being a function of the angle of incidence of the line of sight, the thickness and inclination of the glass pane, and the radius of curvature at the point of incidence.

9.2.1.1.2. Optical distortion in a direction M-M': The algebraic difference in angular deviation $\Delta \alpha$ measured between two points M and M' on the surface of the safety glass pane, the distance between the two points being such that their projections in a plane at right angles to the direction of vision are separated by a given distance Δx (see Figure 6).

Anti-clockwise deviation should be regarded as positive and clockwise deviation as negative.

9.2.1.1.3. Optical distortion at a point M: The optical-distortion maximum for all directions M-M' from the point M.

9.2.1.2. Apparatus

This method entails the projection of an appropriate slide (raster) onto the display screen through the safety-glass pane being tested. The change caused in the shape of the projected image by the insertion of the safety-glass pane in the line of light provides a measure of the distortion.

The apparatus shall comprise the following items, arranged as shown in Figure 9.

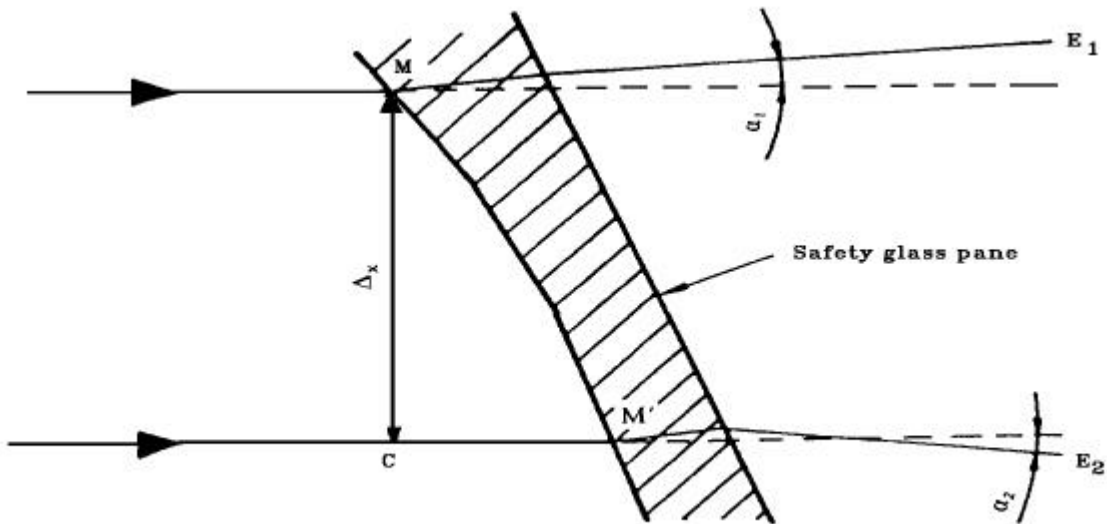

Figure 6
Diagrammatic Representation of Optical Distortion

Notes

$\Delta\alpha = \alpha_1 - \alpha_2$, i.e. the optical distortion in the direction M-M',

$\Delta x = MC$, i.e. the distance between two straight lines parallel to the direction of vision and passing through the points M and M'.

9.2.1.2.1. Projector, of good quality, with a high-intensity point light source, having for example the following characteristics:—

- focal length at least 90 mm;
- aperture approximately 1/2,5;
- 150 W quartz halogen lamp (if used without a filter);
- 250 W quartz halogen lamp (if a green filter is used).

The projector is shown schematically in Figure 7. A diaphragm of 8 mm in diameter is positioned approximately 10 mm from the front lens.

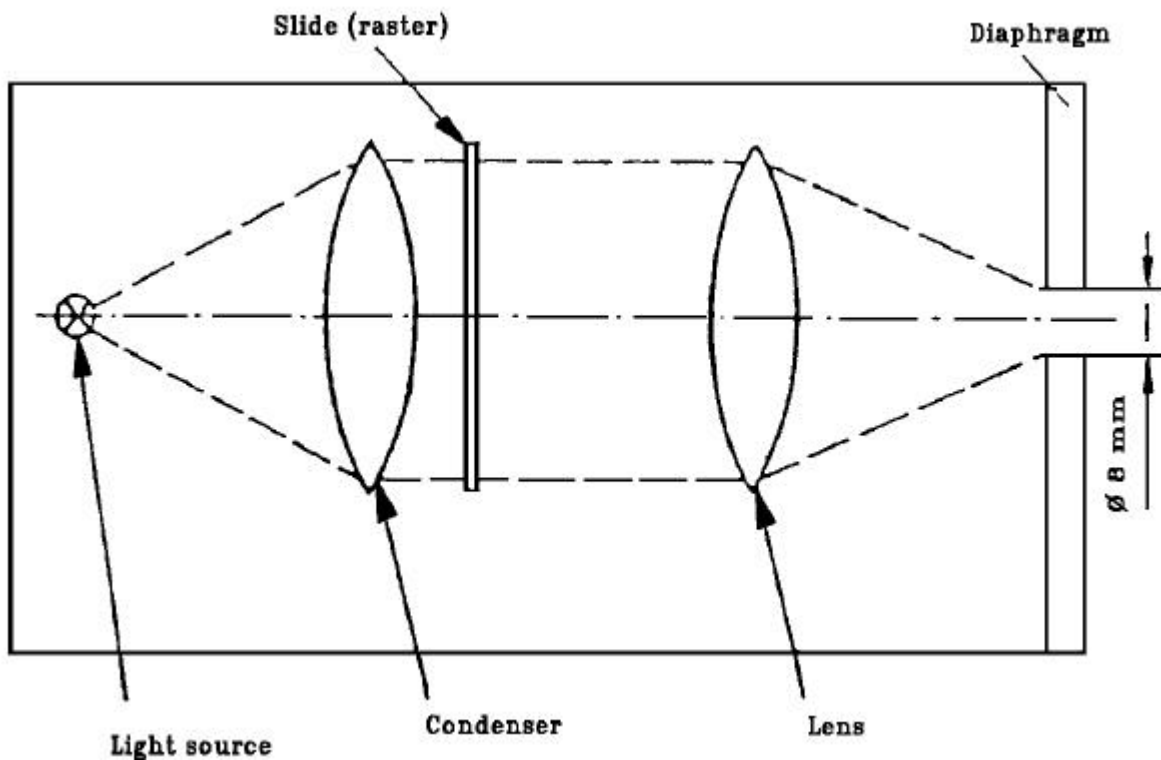

Figure 7
Optical Arrangement of the Projector

9.2.1.2.2. Slides (rasters) consisting, for example, of an array of bright circular shapes on a dark background (see Figure 8). The slides shall be of sufficiently high quality and contrast to enable measurement to be carried out with an error of less than 5%. In the absence of the safety-glass pane to be examined, the dimensions of the circular shapes shall be such that when the circular shapes are projected they form an array of circles of diameter

Install Equation Editor and double
click here to view equation.

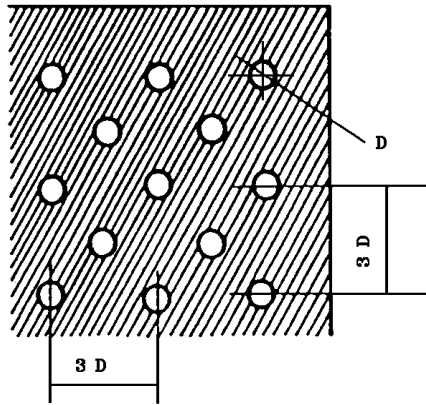
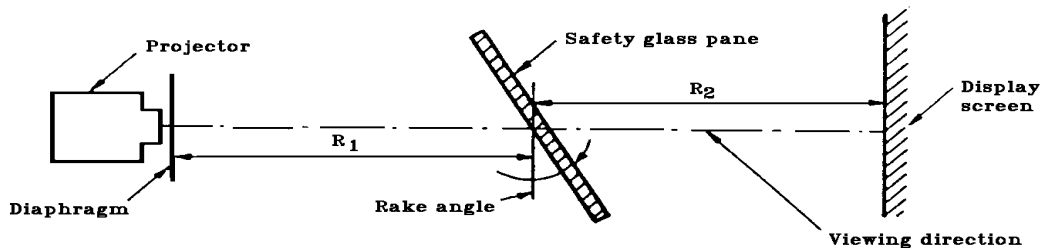

Figure 8
Enlarged Section of the Slide



$R_1 = 4 \text{ m}$
 $R_2 = 2 \text{ m to } 4 \text{ m (4 m preferred)}$

Figure 9
Arrangement of the Apparatus for the Optical Distortion Test

- 9.2.1.2.3. Support stand, preferably one permitting vertical and horizontal scanning, as well as rotation of the safety-glass pane.
- 9.2.1.2.4. Checking template for measuring changes in dimensions where a rapid assessment is required. A suitable design is shown in Figure 10.

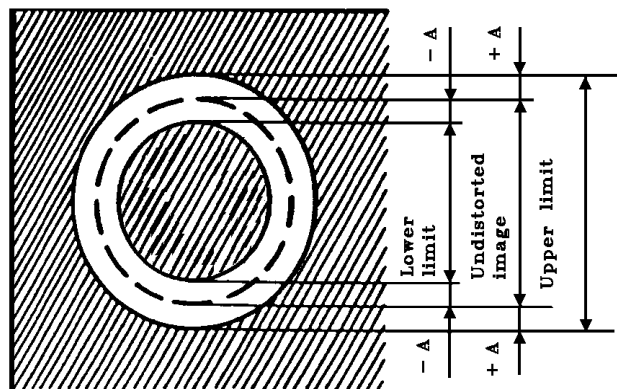

Figure 10
Design for a Suitable Checking Template

9.2.1.3. Procedure

9.2.1.3.1. General

Mount the safety-glass pane on the support stand (Paragraph 9.2.1.2.3.) at the designed rake angle. Project the test image through the area being examined. Rotate the safety-glass pane or move it either horizontally or vertically in order to examine the whole of the specified area.

9.2.1.3.2. Assessment using a checking template

Where a rapid assessment with a possible margin of error of up to 20% is sufficient, calculate the value of A (see Figure 10) from the limit value $\Delta\alpha_L$ for the change in deviation and the value of R_2 , the distance from the safety-glass pane to the display screen:—

$$A = 0,145 \Delta\alpha_L \times R_2$$

The relationship between the change in diameter of the projected image Δd and the change in angular deviation $\Delta\alpha$ is given by

$$\Delta d = 0,29 \Delta\alpha \times R_2,$$

where:—

Δd is in millimetres;
A is in millimetres;
 $\Delta\alpha_L$ is in minutes of arc;
 $\Delta\alpha$ is in minutes of arc;
 R_2 is in metres.

9.2.1.3.3. Measurement using a photoelectric device

Where a precise measurement with a possible margin of error of less than 10% of the limit value is required, measure Δd on the projection axis, the value of the spot width being taken at the point where the luminance is 0,5 times the maximum spot-luminance value.

9.2.1.4. Expression of Results

Evaluate the optical distortion of the safety-glass panes by measuring Δd at any point of the surface and in all directions in order to find Δd_{max} .

9.2.1.5. Alternative Method

In addition, a strioscopic technique is permitted as an alternative to the projection techniques, provided that the accuracy of the measurements given in Paragraphs 9.2.1.3.2. and 9.2.1.3.3. is maintained.

9.2.1.6. The distance Δx shall be 4 mm.

9.2.1.7. The windscreen shall be mounted at the same angle of inclination as on the vehicle.

9.2.1.8. The projection axis in the horizontal plane shall be maintained approximately normal to the trace of the windscreen in that plane.

9.2.2. The measurements shall be performed:

9.2.2.1. For vehicle [Category M_1] in Zone A, extended to the median plane of the vehicle, and in the corresponding part of the windscreen symmetrical to it about the longitudinal median plane of the vehicle, and also in Zone B.

9.2.2.2. For vehicles of [Categories M and N other than M₁], in Zone I as defined in Paragraph 9.2.5.2. of this Annex.

9.2.2.3. For agricultural and forestry tractors and for construction-site vehicles for which it is not possible to determine Zone I, in Zone I' as defined in Paragraph 9.2.5.3. of this Annex.

9.2.2.4. Vehicle Type

The test shall be repeated if the windscreen is to be fitted to a vehicle of a type in which the forward field of vision differs from that of the vehicle type for which the windscreen has already been approved.

9.2.3. Indices of difficulty of the secondary characteristics

9.2.3.1. *Nature of the material*

<u>Polished (Plate) Glass</u>	<u>Float Glass</u>	<u>Sheet Glass</u>
1	1	2

9.2.3.2. Other secondary characteristics

No other secondary characteristics are involved.

9.2.4. *Number of samples*

Four samples shall be submitted for testing.

9.2.5. *Definitions of Zones*

9.2.5.1. Zones A and B of windscreens for [vehicle Category M₁] are defined in Annex 15 to this Regulation.

9.2.5.2. Zones of windscreens for [vehicle Categories M and N other than M₁] are defined on the basis of:—

9.2.5.2.1. **the eye point**, which is the point located 625 mm above the point R of the driver's seat in the vertical plane parallel to the longitudinal median plane of the vehicle for which the windscreen is intended, passing through the axis of the steering wheel. The eye point is hereunder designated "O";

9.2.5.2.2. **the straight line OQ** which is the horizontal straight line passing through the eye point O and perpendicular to the median longitudinal plane of the vehicle.

9.2.5.2.3. Zone I is the windscreen zone determined by the intersection of the windscreen with the four planes defined below:—

P₁ a vertical plane passing through O and forming an angle of 15° to the left of the median longitudinal plane of the vehicle;

P₂ a vertical plane symmetrical to P₁ about the median longitudinal plane of the vehicle;

If this is not possible (in the absence of a symmetrical median longitudinal plane, for instance) P₂ shall be the plane symmetrical to P₁ about the longitudinal plane of the vehicle passing through point O.

P₃ a plane passing through the straight line OQ and forming an angle of 10° above the horizontal plane;

P₄ a plane passing through the straight line OQ and forming an angle of 8° below the horizontal plane.

9.2.5.3. For agricultural and forestry tractors and for construction-site vehicles for which it is not possible to determine Zone I, Zone I' consists in the whole surface of the windscreen.

9.2.6. *Interpretation of results*

A windscreen type shall be considered satisfactory with respect to optical distortion if, in the four samples submitted for testing, optical distortion does not exceed the values given below for each zone.

Vehicle category	Zone	Maximum optical distortion values
M ₁	A. extended according to paragraph 9.2.2.1.	2' of an arc
	B.	6' of an arc
M and N Categories other than M ₁	I	2' of an arc
Agricultural vehicles etc. for which it is not possible to determine zone I	I'	2' of an arc

9.2.6.1. For [vehicles of Categories M and N], no measurements shall be made in a peripheral area 25 mm wide.

9.2.6.2. For agricultural and forestry tractors and for construction-site vehicles, no measurements shall be made in peripheral area 100 mm wide.

9.2.6.3. In the case of split windscreens, no measurements shall be made in a strip 35 mm from the edge of the pane which is to be adjacent to the dividing pillar.

9.2.6.4. A maximum value of 6' of arc is permitted for all portions of Zone I or Zone A which are less than 100 mm from the edge of the windscreen.

9.2.6.5. Slight deviations from the requirements may be allowed in Zone B provided they are localised and recorded in the report.

9.3. **Secondary-Image-Separation Test**

9.3.1. *Scope*

Two test methods are recognised:—

- target test; and
- collimation-telescope test.

9.3.1.1. Target test

9.3.1.1.1. Apparatus

This method involves viewing an illuminated target through the safety-glass pane. The target may be designed in such a way that the test can be carried out on a simple 'go-no go' basis.

The target shall preferably be of one of the following types; that is to say, either

- a) an illuminated 'ring' target whose outer diameter, D , subtends an angle of η minutes of arc at a point situated at x metres (Figure 11 a)), or
- b) an illuminated 'ring and spot' target whose dimensions are such that the distance, D , from a point on the edge of the spot to the nearest point on the inside of the circle subtends an angle of η minutes of arc at a point situated at x metres (Figure 11 b)), where

η is the limit value of secondary-image separation,

x is the distance from the safety-glass pane to the target (not less than 7 m),

D is given by the formula : $D = x \cdot \text{tg } \eta$

The illuminated target consists of a light box, approximately 300 mm x 300 mm x 150 mm, whose front is most conveniently constructed of glass masked with opaque black paper or coated with matt black paint.

The box shall be illuminated by a suitable light source. It may be convenient to use other forms of target, such as that shown in Figure 14. It is also acceptable to replace the target system by a projection system and to view the resulting images on a screen.

9.3.1.1.2. Procedure

Mount the safety-glass pane at the specified rake angle on a suitable stand in such a way that the observation is carried out in the horizontal plane passing through the centre of the target.

The light box shall be viewed, in a dark or semi-dark room, through each part of the area being examined, in order to detect the presence of any secondary image associated with the illuminated target.

Rotate the safety-glass pane as necessary to ensure that the correct direction of view is maintained. A monocular may be used for viewing.

9.3.1.1.3. Expression of results

Determine whether:—

When target (a) (see Figure 11 a)) is used, the primary and secondary images of the circle separate, i.e. whether the limit value of η is exceeded, or

When target (b) (see Figure 11 b)) is used, the secondary image of the spot shifts beyond the point of tangency with the inside edge of the circle, i.e. whether the limit value of η is exceeded.

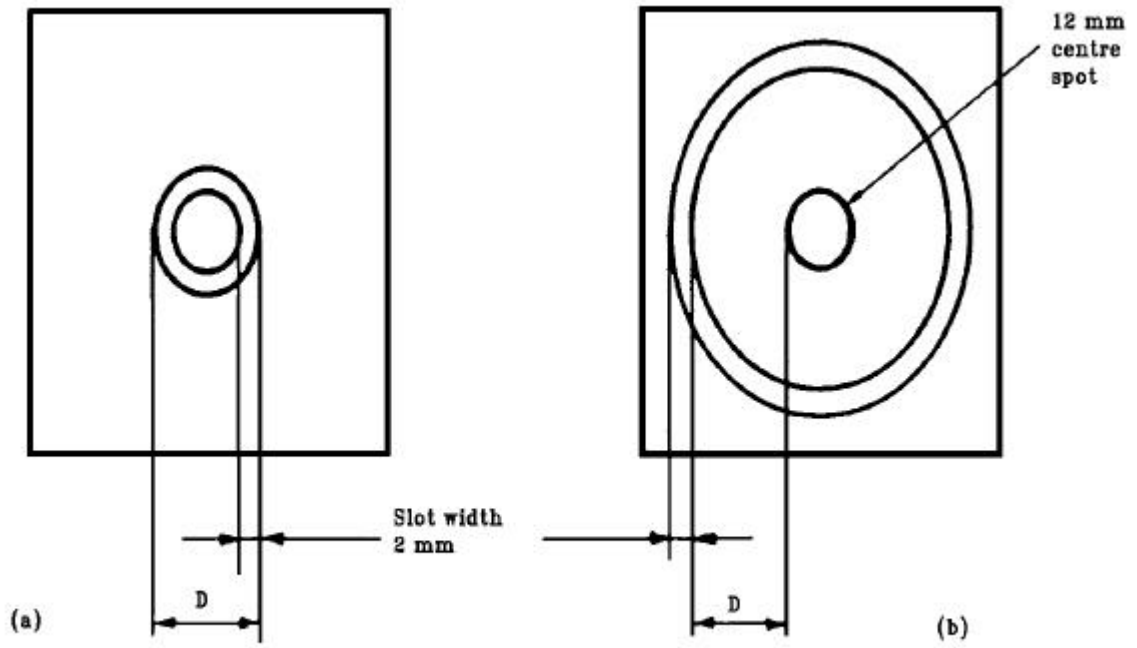

Figure 11

Dimensions of target

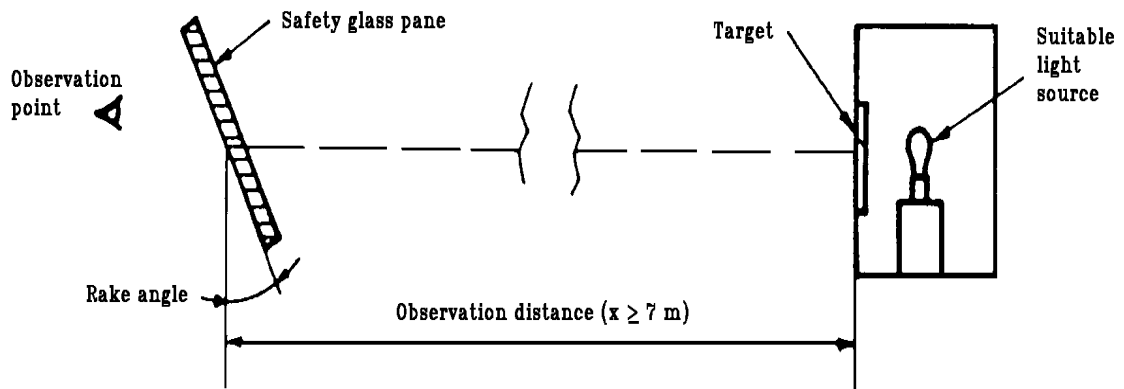
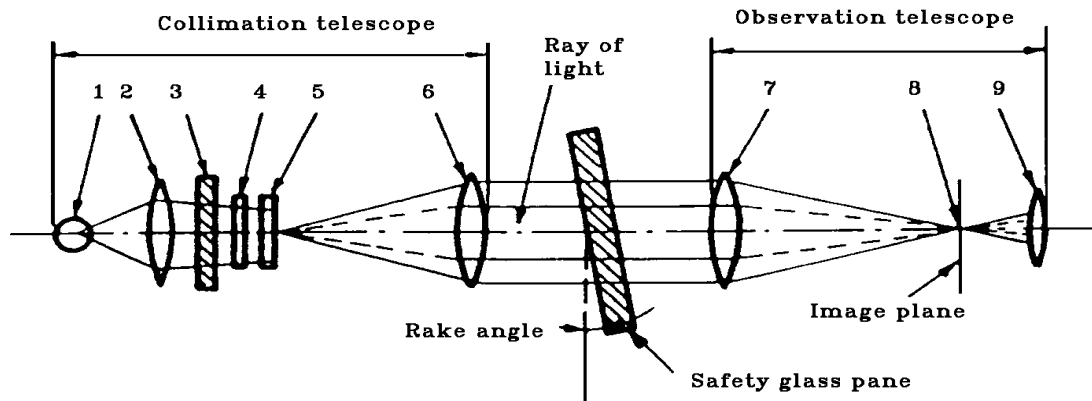

Figure 12

Arrangement of Apparatus



- (1) Lamp bulb
- (2) Condenser aperture > 8.6 mm
- (3) Ground-glass screen aperture > condenser aperture
- (4) Colour filter with central hole approximately 0.3 mm in diameter, diameter > 8.6 mm
- (5) Polar co-ordinate plate, diameter > 8.6 mm
- (6) Achromatic lens, $f \geq 86$ mm, aperture 10 mm
- (7) Achromatic lens, $f \geq 86$ mm, aperture 10 mm
- (8) Black spot, diameter approximately 0.3 mm
- (9) Achromatic lens, $f = 20$ mm, aperture < 10 mm.

Figure 13

Apparatus for Collimation-Telescope Test

9.3.1.2. Collimation-telescope test

If necessary, the procedure described in this paragraph shall be applied.

9.3.1.2.1. Apparatus

The apparatus comprises a collimator and a telescope and may be set up in accordance with Figure 13. However, any equivalent optical system may be used.

9.3.1.2.2. Procedure

The collimation telescope forms at infinity the image of a polar co-ordinate system with a bright point at its centre (see Figure 14).

In the focal plane of the observation telescope, a small opaque spot with a diameter slightly larger than of the projected bright point is placed on the optical axis, thus obscuring the bright point.

When a test piece which exhibits a secondary image is placed between the telescope and the collimator, a second, less bright point appears at a certain distance from the centre of the polar co-ordinate system. The secondary-image separation can be read out as the distance between the points seen through the observation telescope (see Figure 14).

(The distance between the dark spot and the bright point at the centre of the polar co-ordinate system represents the optical deviation.)

9.3.1.2.3. Expression of Results

The safety-glass pane shall first be examined by a simple scanning technique to establish the area giving the strongest secondary image. That area shall then be examined by the collimator-telescope system at the appropriate angle of incidence. The maximum secondary -image separation shall be measured.

9.3.1.3. The direction of observation in the horizontal plane shall be maintained approximately normal to the trace of the windscreen in that plane.

9.3.2. The measurement shall be performed in the zones as defined in Paragraph 9.2.2. above according to the vehicle categories.

9.3.2.1. Vehicle Type

The test shall be repeated if the windscreen is to be fitted to a vehicle of a type in which the forward field of vision different from that of the vehicle type for which the windscreen has already been approved.

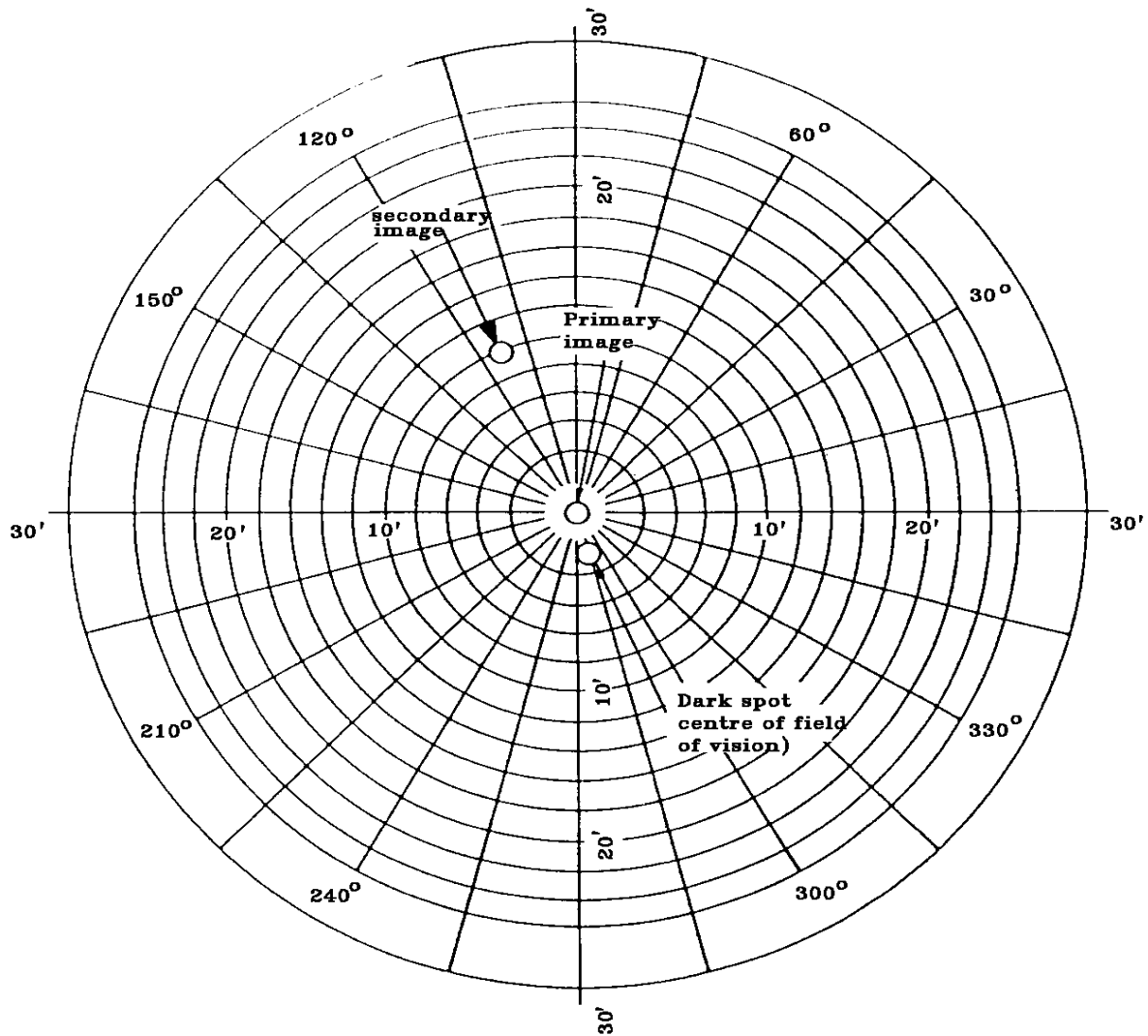

Figure 14

Example of Observation by the Collimation-Telescope Test Method

9.3.3. Indices of difficulty of the secondary characteristics

9.3.3.1. Nature of the material

Polished (Plate) Glass

Float Glass

Sheet Glass

1

1

2

9.3.3.2. Other secondary characteristics

No other secondary characteristics are involved.

9.3.4. *Number of samples*

Four samples shall be submitted for testing.

9.3.5. *Interpretation of results*

A windscreen type shall be considered satisfactory with respect to secondary-image separation if, in the four samples submitted for testing, separation of the primary and secondary image does not exceed the values given below for each zone.

Vehicle category	Zone	Maximum optical distortion values
M ₁	A. extended according to paragraph 9.2.2.1.	15' of an arc
	B.	25' of an arc
M and N Categories other than M ₁	I	15' of an arc
Agricultural vehicles etc. for which it is not possible to determine zone I	I'	15' of an arc

9.3.5.1. For [vehicles of Categories M and N], no measurements shall be made in a peripheral area 25 mm wide.

9.3.5.2. For agricultural and forestry tractors and for construction-site vehicles, no measurements shall be made in a peripheral area 100 mm wide.

9.3.5.3. In the case of split windscreens, no measurements shall be made in a strip 35 mm from the edge of the glass pane which is to be adjacent to the dividing pillar.

9.3.5.4. A maximum value of 25' of arc is permitted for all portions of Zone I or Zone A which are less than 100 mm from the edge of the windscreen.

9.3.5.5. Slight deviations from the requirements may be allowed in Zone B provided they are localized and recorded on the report.

10. BURNING BEHAVIOUR (FIRE-RESISTANCE) TEST

10.1. Purpose and scope of application

This method enables the horizontal burning rate of materials used in the passenger compartment of motor vehicles (for example private passenger cars, lorries (trucks), estate cars, motor coaches) after exposure to a small flame to be determined.

This method permits testing of materials and components of a vehicle interior equipment individually or in combination up to a thickness of 13 mm. It is used to judge the uniformity of production lots of such materials with respect to their burning behaviour.

Because of the many differences between the real-world situation (application and orientation within a vehicle, conditions of use, ignition source, etc.) and the precise test conditions prescribed herein, this method cannot be considered as suitable for evaluation of all true in-vehicle burning characteristics.

10.2. Definitions

10.2.1. **Burning Rate:** The quotient of the burnt distance measured according to this method and the time taken to burn that distance.

It is expressed in millimetres per minute.

10.2.2. **Composite Material:** A material composed of several layers of similar or different materials intimately held together at their surfaces by cementing, bonding, cladding, welding, etc.

When different materials are connected together intermittently (for example, by sewing, high-frequency welding, riveting), then in order to permit the preparation of individual samples in accordance with Paragraph 10.5. below such materials shall not be considered as composite materials.

10.2.3. **Exposed Side:** The side which is facing towards the passenger compartment when the material is mounted in the vehicle.

10.3. Principle

A sample is held horizontally in a U-shaped holder and is exposed to the action of a defined low-energy flame for 15 seconds in a combustion chamber, the flame acting on the free end of the sample.

The test determines whether and when the flame is extinguished or the time which the flame requires to proceed over a measured distance.

10.4. **Apparatus**

10.4.1. Combustion chamber (Figure 15), preferably of stainless steel, having the dimensions given in Figure 16.

The front of the chamber contains a flame-resistant observation window, which may cover the entire front and which can be constructed as an access panel.

The bottom of the chamber has vent holes, and the top has a vent slot all around.

The combustion chamber is placed on four feet, 10 mm high. The chamber may have a hole at one end for the introduction of the sample holder containing the sample; in the opposite end, a hole is provided for the gas-supply line. Melted material is caught in a pan (see Figure 17) which is placed on the bottom of the chamber between vent holes without covering any vent hole area.

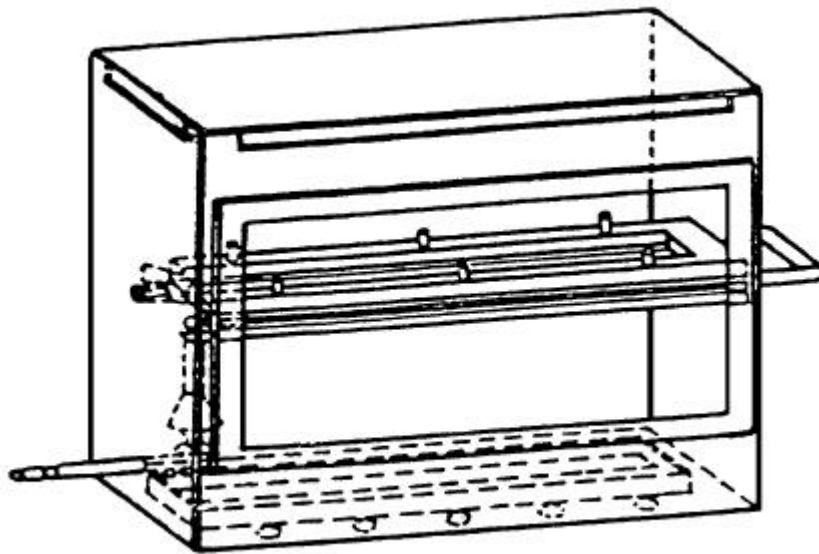

Figure 15

**Example of Combustion Chamber with Sample
Holder and Drip Pan**

10.4.2. Sample holder, consisting of two U-shaped metal plates or frames of corrosion-proof material. Dimensions are given in Figure 18.

The lower plate is equipped with pins and the upper one with corresponding holes, in order to ensure a consistent holding of the sample. The pins also serve as measuring points at the beginning and end of the burning distance.

A support shall be provided in the form of heat-resistant wires 0,25 mm in diameter spanning the frame at 25 mm intervals over the bottom U-shaped frame (see Figure 19).

The plane of the lower side of samples shall be 178 mm above the floor plate. The distance of the front edge of the sample holder from the end of the chamber shall be 22 mm; the distance of the longitudinal sides of the sample holder from the sides of the chamber shall be 50 mm (all inside dimensions). (See Figures 15 and 16.)

10.4.3. *Gas burner*

The small ignition source is provided by a Bunsen burner having an inside diameter of 9,5 mm. It is so located in the test cabinet that the centre of its nozzle is 19 mm below the centre of the bottom edge of the open end of the sample (see Figure 16).

10.4.4. *Test gas*

The gas supplied to the burner shall have a calorific value of about 38 MJ/m³ (for example natural gas).

10.4.5. Metal comb, at least 110 mm in length, with seven or eight smooth rounded teeth per 25 mm.

10.4.6. Stop-watch, accurate to 0,5 seconds.

10.4.7. *Fume cupboard*

The combustion chamber may be placed in a fume-cupboard assembly provided that the latter internal volume is at least 20 times, but not more than 110 times greater than the volume of the combustion chamber and provided that no single height, width, or length dimension of the fume cupboard is greater than 2.5 times either of the other two dimensions.

Before the test, the vertical velocity of the air through the fume cupboard shall be measured 100 mm forward of and to the rear of the ultimate site of the combustion chamber. It shall be between 0,10 and 0,30 m/s in order to avoid possible discomfort to the operator from combustion products. It is possible to use a fume cupboard with natural ventilation and an appropriate air velocity.

Dimensions in millimetres
Tolerances according to ISO 2768

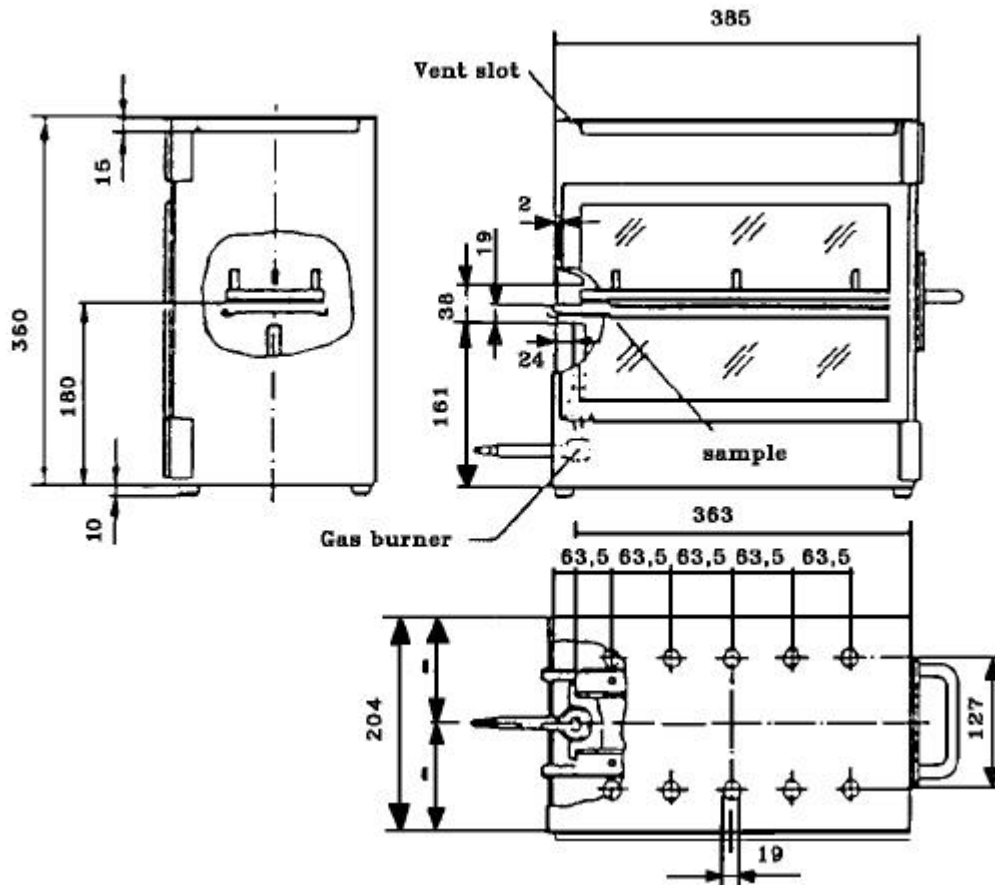

Figure 16
Example of combustion chamber

Dimensions in millimetres
Tolerances according to ISO 2768

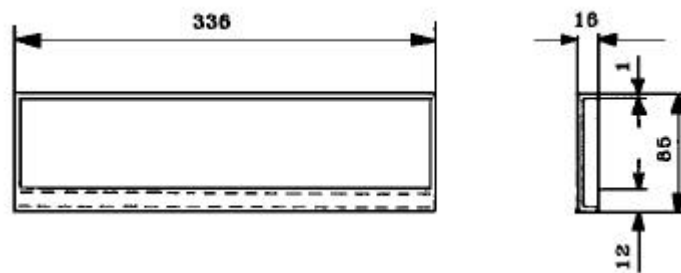

Figure 17
Typical drip pan

Dimensions in millimetres
Tolerances according to ISO 2768

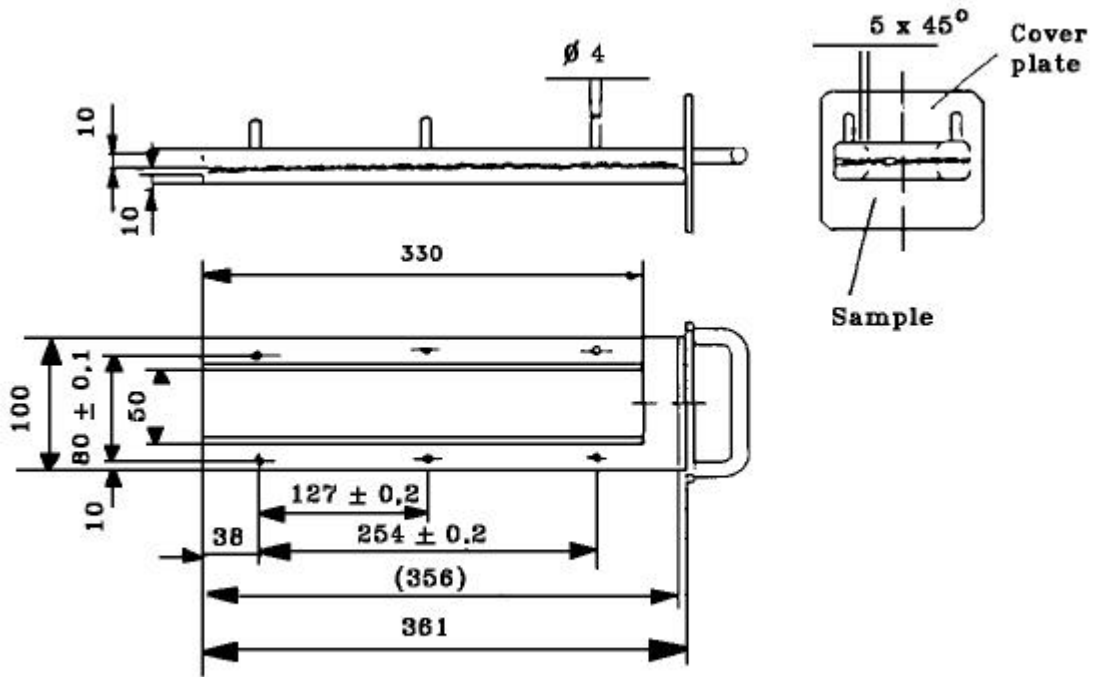

Figure 18
Example of sample holder

Dimensions in millimetres
Tolerances according to ISO 2768

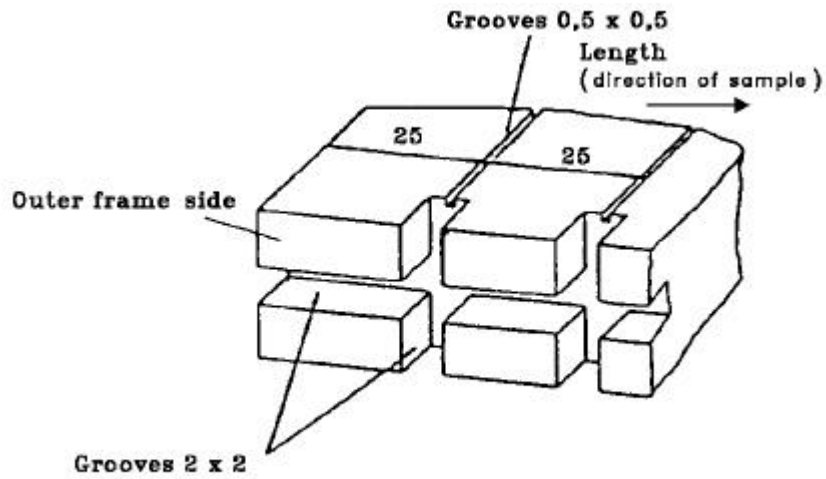

Figure 19
Example of section of lower U-frame design for wire support facility

10.5. **Samples**

10.5.1. *Shape and dimensions*

The shape and dimensions of samples are given in Figure 20. The thickness of the sample corresponds to the thickness of the product to be tested. It shall not be more than 13 mm. When sample-taking so permits, the sample shall have a constant section over its entire length.

When the shape and dimensions of a product do not permit taking a sample of the given size, the following minimum dimensions shall be observed:—

- a) For samples having a width of 3 to 60 mm, the length shall be 356 mm. In this case the material is tested over the product width;
- b) For samples having a width of 60 to 100 mm, the length shall be at least 138 mm. In this case the potential burning distance corresponds to the length of the sample, the measurement starting at the first measuring point;
- c) Samples less than 60 mm wide and less than 356 mm long, and samples 60 to 100 mm wide and less than 138 mm long, cannot be tested according to the present method, nor can samples less than 3 mm wide.

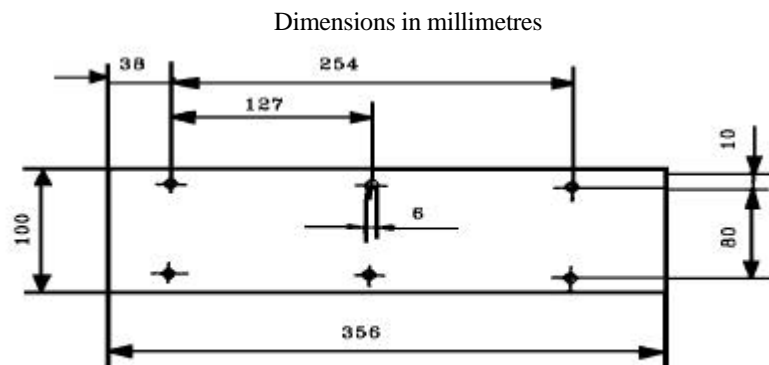

Figure 20
Sample

10.5.2. *Sampling*

Five samples shall be taken from the material under test. In materials having burning rates differing according to the direction of the material (this being established by preliminary tests) the five (or more) samples shall be taken and be placed in the test apparatus in such a way that the highest burning rate will be measured.

When the material is supplied in set widths, a length of at least 500 mm covering the entire width shall be cut. From the piece so cut, the samples shall be taken at not less than 100 mm from the edge of the material and at points equidistant from each other.

Samples shall be taken in the same way from finished products when the shape of the product so permits. If the thickness of the product is over 13 mm it shall be reduced to 13 mm by a mechanical process applied to the side which does not face the passenger compartment.

Composite materials (see Paragraph 10.2.2.) shall be tested as if they were homogeneous.

In the case of materials comprising superimposed layers of different composition which are not composite materials, all the layers of material included within a depth of 13 mm from the surface facing towards the passenger compartment shall be tested individually.

10.5.3. *Conditioning*

The samples shall be conditioned for at least 24 hours, but not more than 7 days, at a temperature of $23 \pm 2^\circ\text{C}$ and a relative humidity of $50 \pm 5\%$, and shall be maintained under these conditions until immediately prior to testing.

10.6. **Procedure**

10.6.1. Place samples with napped or tufted surfaces on a flat surface, and comb twice against the nap using the comb (Paragraph 10.4.5.).

10.6.2. So place the sample in the sample holder (Paragraph 10.4.2.) that the exposed side faces downwards, towards the flame.

10.6.3. Adjust the gas flame to a height of 38 mm using the mark in the chamber, the air intake of the burner being closed. The flame shall burn for at least one minute, for stabilisation, before the first test is started.

10.6.4. Push the sample holder into the combustion chamber so that the end of the sample is exposed to the flame, and after 15 seconds cut off the gas flow.

10.6.5. Measurement of burning time starts at the moment when the foot of the flame passes the first measuring point. Observe the flame propagation on the side (upper or lower) which burns faster.

10.6.6. Measurement of burning time is completed when the flame has come to the last measuring point or when the flame is extinguished before reaching that point. If the flame does not reach the last measuring point, measure the burnt distance up to the point where the flame was extinguished. Burnt distance is the part of the sample destroyed, on the surface or inside, by burning.

10.6.7. If the sample does not ignite or does not continue burning after the burner has been extinguished, or the flame goes out before reaching the first measuring point, so that no burning time is measured, note in the test report that the burning rate is 0 mm/min.

10.6.8. When running a series of tests or performing repeat tests, make sure before starting a test that the temperature of the combustion chamber and sample holder does not exceed 30°C .

10.7. **Calculation**

The burning rate B, in millimetres per minute, is given by the formula:-

$$B = \frac{s}{t} \times 60$$

where:

s is the burnt distance, in millimetres;

t is the time, in seconds, taken to burn the distance s.

10.8. **Indices of difficulty of the secondary characteristics**

No secondary characteristics are involved.

10.9. **Interpretation of results**

10.9.1 **The safety glazing shall be considered satisfactory from the point of view of the fire-resistance test if the rate**

of burning does not exceed 90 mm/min.

11. TEST OF RESISTANCE TO CHEMICALS

11.1 Chemicals used for the test

11.1.1. **Non-abrasive soap solution:** 1% by weight of potassium oleate in deionized water;

11.1.2. **Window-cleaning solution:** an aqueous solution of isopropanol and dipropylene glycol monomethyl ether in concentration between 5 and 10% by weight each and ammonium hydroxide in concentration between 1 and 5% by weight;

11.1.3. **Undiluted denatured alcohol:** 1 part by volume methyl alcohol in 10 parts by volume ethyl alcohol;

11.1.4. **Petrol or equivalent reference petrol:** a mixture of 50% by volume toluene, 30% by volume 2,2,4-trimethylpentane, 15% by volume 2,4,4-trimethyl-1-pentene and 5% by volume ethyl alcohol; N.B. The composition of the petrol used shall be recorded in the test report.

11.1.5. **Reference kerosene:** a mixture of 50% by volume n-octane and 50% by volume n-decane.

11.2. Test method

11.2.1. Test procedure under load

11.2.1.1. The test specimen shall be simply supported as a horizontal level arm between a fixed supporting edge at one end in such a way that the entire width will rest on a cutting edge (fulcrum) which is 51 mm from the fixed end support. A load shall be suspended from the free end of the test specimen at a distance of 102 mm from the fulcrum as shown in Figure

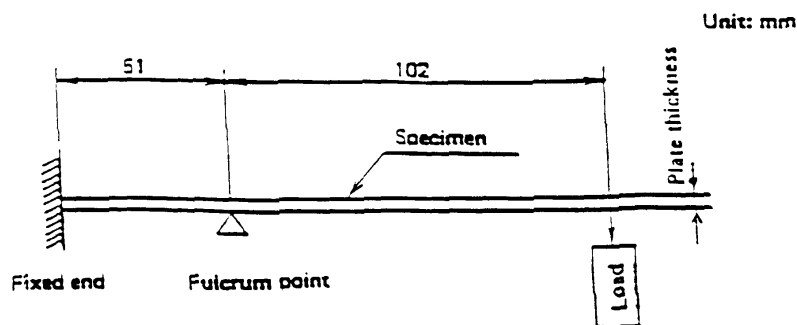

Method of setting up the test specimen

11.2.1.2. The load mass shall be $28.7t^2$ g where t is the thickness in mm of the test specimen. The resulting stress on the outer fibre of the test specimen is approximately 6.9 MPa.

Example: For a 3 mm thick test specimen placed horizontally between a downward fixed edge and an upward fulcrum edge separated by 51 mm the applied downward load at 102 mm from the fulcrum is to be 258 g.

- 11.2.1.3. While the test specimen is stressed, one of the prescribed chemicals shall be applied to the top surface of the test specimen above the fulcrum point. The chemical shall be applied with a soft, 13 mm wide brush, wetted before each stroke. Ten individual strokes at 1 s intervals across the width of the test specimen, avoiding the end and edges, shall be required.

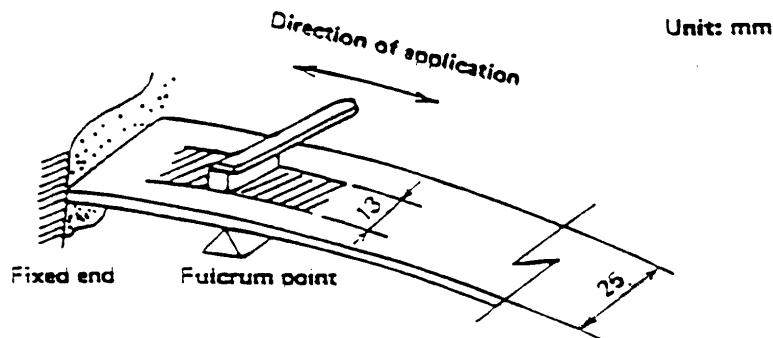

Method of Applying Chemicals to the Test Specimen

11.3. **Indices of difficulty of the secondary characteristics**

	<u>Colourless</u>	<u>Tinted</u>
Colouring of the plastics coating or plastic glazing	1	2

The other secondary characteristics are not concerned.

11.4. **Interpretation of results**

11.4.1. The test for resistance to chemical agents shall be considered to have given a satisfactory result if the test piece does not exhibit any softening, tackiness, crazing or apparent loss of transparency.

11.4.2. A set of test pieces shall be considered acceptable if all the tests give a satisfactory result.

12. FLEXIBILITY TEST AND FOLD TEST

12.1. Scope

With this test has to be found out whether a plastic is to be classed into the categories or rigid or flexible plastics.

12.2. Test Method

From the material of the nominal thickness a rectangular flat sample 300 mm long and 25 mm wide is cut out and horizontally clamped into a clamping device in such a way that 275 mm of the length of the sample freely extend over the holding device. This free end shall be supported horizontally by an appropriate device until the test begins. 60 seconds after removal of this support the vertical deviation of the free end is indicated in mm. If this deviation exceeds 50 mm a 180° fold test is performed subsequently. The sample is folded concisely, after that it is folded round 0.5 mm thick piece of sheet metal in such a way that it tightly contacts it on both sides.

12.3. Test Conditions

— Temperature: 20 degrees ± 2 degrees celsius.

— Relative Humidity: 60% ± 5%

12.4. Requirements

The vertical deviation must be more than 50 mm for flexible plastics, and 10 seconds after a 180° - folding the material must not show any fracture-like damages at the point of buckling.

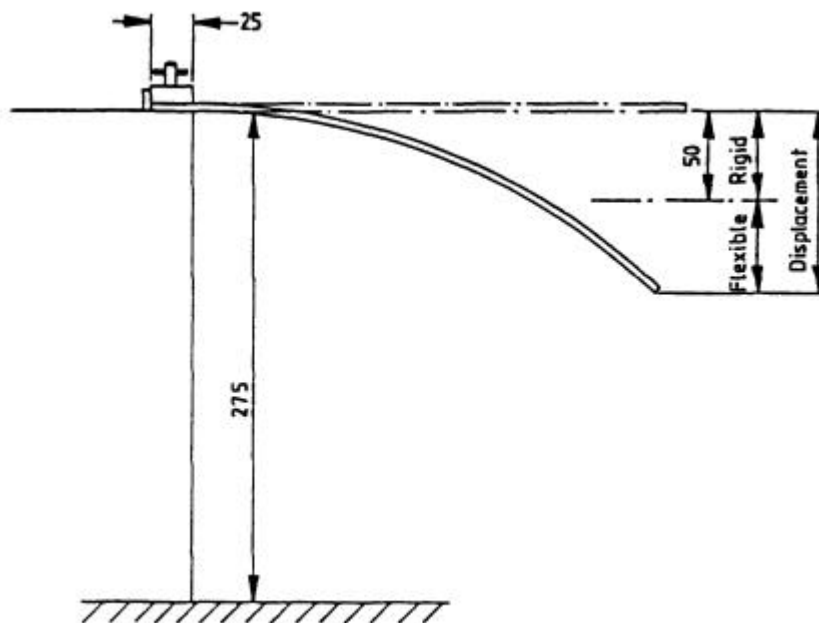

Dimensions in millimetres

Figure 1

Arrangement of flexibility test

13. CROSS-CUT TEST

13.1. Scope

This test gives a simple method to determine the adhesion of coatings to the subsurface. The brittleness and other strength characteristics can be evaluated.

13.2. Apparatus

Cutting tool with 6 blades set at 1 mm apart. A magnifying glass with an enlargement of 2 x to examine the crosscut specimen.

Tool with Six Blades

13.3. Test Method

so that Cut through the coating on to the subsurface a pattern with 6 cuts and perpendicular to this another one a grid with 25 squares arises (grid-cut).

but do The cutting tool should be drawn steadily with a speed of 2 to 5 cm/s so that the cuts reach the subsurface not penetrate too deeply.

The cutting is conducted in such a way that the two leading heads at the edge of the apparatus touch the **uniformly. After the test the cuts are examined with a magnifying glass to check that they reach the subsurface. The test is carried out at least at two different positions of the specimen. After the cuts have been produced they are brushed 5 times with slight pressure in both diagonal directions with a hand brush with polyamide bristles.**

13.4. Interpretation of Results

the

The grid cuts are examined with a magnifying glass. If the cut edges are perfectly smooth and if no part of coating is detached then a cross cut value of Gt0 will be given. If there are small fragments detached at the intersection of the cuts and if the exposed area amounts to about 5% of the grid area the cut value is Gt1.

Larger areas of detachment will be graded in the range Gt2 to Gt5.

ANNEX 4

TOUGHENED GLASS WINDSCREENS

1. DEFINITION OF TYPE

Toughened-glass windscreens shall be deemed to belong to different types if they differ in at least one of the following principal or secondary characteristics:—

1.1. The principal characteristics are as follows:—

1.1.1. The manufacturer's trade name or marks;

1.1.2. The shape and dimensions.

Toughened-glass windscreens shall be considered as belonging to one or other of two groups for the purposes of fragmentation and mechanical properties tests, i.e.;

1.1.2.1. Flat windscreens, and

1.1.2.2. Curved windscreens.

1.1.3. The thickness category in which the nominal thickness 'e' lies (a manufacturing tolerance of $\pm 0,2$ mm being allowed):—

Category I $e \leq 4,5$ mm;

Category II $4,5 \text{ mm} < e \leq 5,5$ mm;

Category III $5,5 \text{ mm} < e \leq 6,5$ mm; and

Category IV $6,5 \text{ mm} < e$.

1.2. The secondary characteristics are as follows:—

1.2.1. Nature of the material (polished (plate) glass, float glass, sheet glass);

1.2.2. Colouring (colourless or tinted);

1.2.3. The incorporation or otherwise of conductors;

1.2.4. The incorporation or otherwise of obscuration bands.

2. FRAGMENTATION TEST

2.1. Indices of difficulty of the secondary characteristics

2.1.1. Only the nature of the material is involved.

2.1.2. Float glass and sheet glass are considered to have the same index of difficulty.

2.1.3. The fragmentation tests must be repeated on transition from polished (plate) glass to float glass or sheet glass, and vice versa.

2.1.4. The tests must be repeated if obscuration bands other than painted bands are used.

2.2. Number of samples

Six samples will be tested.

2.3. **Different zones of glass**

A toughened-glass windscreen shall comprise two main zones, FI and FII. It may also comprise an intermediate zone, FIII.

These zones are as defined below.

2.3.1. Zone FI: Peripheral zone of fine fragmentation, at least 7 cm wide, all round the edge of the windscreen and including an outer strip 2 cm wide not subjected to assessment;

2.3.2. Zone FII: Visibility zone of varying fragmentation, always including a rectangular part at least 20 cm high and 50 cm long;

2.3.2.1. For [vehicles of Category M₁], the centre of the rectangle shall be inside a circle having a radius of 10 cm centred on the projection of the middle of segment V₁-V₂.

2.3.2.2. For [vehicles of Categories M and N other than M₁], the centre of the circle having a radius of 10 cm centred on the projection of point O;

2.3.2.3. For agricultural and forestry tractors and for construction-

2.3.2.4. site vehicles, the position of the visibility zone shall be indicated in the test report.

2.3.2.4. The height of the above rectangle may be reduced to 15 cm for windscreens which are less than 44 cm high.

2.3.3. Zone FIII: intermediate zone, not more than 5 cm wide, between Zones FI and FII.

2.4. **Test method**

The method used shall be that described in Annex 3, Paragraph 1.

2.5. **Points of impact (see Annex 16, Figure 2)**

2.5.1. The points of impact shall be selected as follows:—

Point 1: In the central part of Zone FII in an area of high or low stress;

Point 2: In Zone FIII, as near as possible to the vertical plane of symmetry of Zone FII;

Points 3 and 3': 3 cm from the edges of one median of the sample; when there is a tong mark, one of the breakage points shall be near the edge bearing the tong mark and the other near the opposite edge;

Point 4: At the place where radius of curvature is smallest on the longest median;

Point 5: 3 cm from the edge of the sample at the place where the radius of curvature of the edge is smallest, either to the left or to the right.

2.5.2. A fragmentation test shall be performed at each of the Points 1, 2, 3, 3', 4 and 5.

2.6. **Interpretation of results**

2.6.1. A test shall be deemed to have given a satisfactory result if fragmentation satisfies all the conditions given in Paragraphs 2.6.1.1., 2.6.1.2. and 2.6.1.3. below.

2.6.1.1. Zone FI:

- 2.6.1.1.1. The number of fragments in any 5 cm x 5 cm square is not less than 40 nor more than 350; however in the case of a count of less than 40, if the number of fragments in any 10 cm x 10 cm square containing the 5 cm x 5 cm square is not less than 160, this shall be acceptable.
- 2.6.1.1.2. For the purposes of the above rule, a fragment extending across a side of a square shall count as half a fragment;
- 2.6.1.1.3. Fragmentation shall not be checked in a strip 2 cm wide round the edge of the samples, this strip representing the frame of the glass, nor within a radius of 7,5 cm from the point of impact.
- 2.6.1.1.4. A maximum of 3 fragments of an area exceeding 3 cm² shall be allowed. No two of these fragments shall be contained within the same 10 cm diameter circle.
- 2.6.1.1.5. Elongated fragments may be permitted provided that their ends are not knife-edged and that their length does not exceed 7,5 cm, except in the case provided for in Paragraph 2.6.2.2. below. If these elongated fragments extend to the edge of the glass, they must not form an angle of more than 45° with it.
- 2.6.1.2. Zone FII:
- 2.6.1.2.1. The residual visibility after shattering shall be checked in the rectangular area defined in Paragraph 2.3.2. above. In that rectangle the aggregate surface area of the fragments of more than 2 cm² shall represent not less than 15% of the area of the rectangle; however, in the case of windscreens less than 44 cm high, or whose angle of installation is less than 15° from the vertical, the visibility percentage shall at least be equal to 10% of the surface of the corresponding rectangle.
- 2.6.1.2.2. No fragment shall have an area of more than 16 cm² except in the case provided for in Paragraph 2.6.2.2. below.
- 2.6.1.2.3. Within a radius of 10 cm from the point of impact, but only in that part of the circle which is included in Zone FII, three fragments having an area of more than 16 cm² but less than 25 cm² shall be allowed.
- 2.6.1.2.4. Fragments shall be substantially regular in shape and free from points of the type described in Paragraph 2.6.1.2.4.1. below. However, not more than 10 irregular fragments shall be allowed in any 50 x 20 cm rectangle and not more than 25 over the whole surface of the windscreen.
- No such fragment shall present a point more than 35 mm long measured in accordance with Paragraph 2.6.1.2.4.1. below.
- 2.6.1.2.4.1. A fragment shall be considered an irregular fragment if it cannot be inscribed in a circle of 40 mm in diameter, if it has at least one point more than 15 mm long when measured from the top of the point to the section whose width is equal to the glazing thickness, and if it has one or more points having a top angle smaller than 40°.
- 2.6.1.2.5. Fragments of elongated shape shall be allowed in Zone FII as a whole, provided they do not exceed 10 cm in length, except in the case provided for in Paragraph 2.6.2.2. below.
- 2.6.1.3. Zone FIII:
- Fragmentation in this zone must have characteristics intermediate between those of the fragmentations respectively allowed for the two neighbouring zones (FI and FII).
- 2.6.2. A windscreen shall be considered satisfactory from the point of view of fragmentation if at least one of the following conditions is fulfilled:
- 2.6.2.1. When all the tests carried out using the points of impact defined in Paragraph 2.5.1. above have given a satisfactory result;

2.6.2.2. When one test among all those carried out using the points of impact prescribed in Paragraph 2.5.1. has given an unsatisfactory result, taking account of deviations which do not exceed the following limits:

Zone FI: not more than five fragments between 7.5 and 15 cm long,

Zone FII: not more than three fragments of between 16 and 20 cm² in area located outside the circle having a radius of 10 cm centred on the point of impact,

Zone FII: not more than four fragments between 10 and 17,5 cm long.

and is repeated on a new sample, which either conforms to the requirements of Paragraph 2.6.1. or presents deviations within the above specified limits.

2.6.2.3. When two tests among all the tests carried out using the points of impact prescribed in Paragraph 2.5.1. have given an unsatisfactory result for deviations not exceeding the limits specified in Paragraph 2.6.2.2., and a further series of tests carried out on a new set of samples conforms to the requirements of Paragraph 2.6.1., or not more than two samples of the new set present deviations within the above specified limits of Paragraph 2.6.2.2.

2.6.3. If the above-mentioned deviations are found, they shall be noted in the test report and photographs of the relevant parts of the windscreen shall be attached to the report.

3. HEADFORM TEST

3.1. Indices of difficulty of the secondary characteristics

No secondary characteristic is involved.

3.2. Number of samples

3.2.1. Four windscreens shall be tested.

3.3. Test Method

3.3.1. The method used shall be that described in Annex 3, Paragraph 3.1.

3.3.2. The height of drop shall be 1,5 m $\begin{matrix} + 0 \\ - 5 \text{ mm.} \end{matrix}$

3.4. Interpretation of Results

3.4.1. A test shall be deemed to have given a satisfactory result if the windscreen is fractured.

3.4.2. A set of samples shall be considered acceptable if at least three of the four tests give a satisfactory result.

4. OPTICAL QUALITIES

The requirements concerning optical qualities set out in Annex 3, Paragraph 9, shall apply to every type of windscreen.

ANNEX 5

UNIFORMLY-TOUGHENED GLASS PANES ⁽¹⁾

1. DEFINITION OF TYPE

Uniformly-toughened glass panes shall be deemed to belong to different types if they differ in at least one of the following principal or secondary characteristics.

1.1. The principal characteristics are as follows:—

1.1.1. The manufacturer's trade name or marks;

1.1.2. The nature of the toughening process (thermal or chemical);

1.1.3. The thickness category in which the nominal thickness "e" lies (a manufacturing tolerance of $\pm 0,2$ mm being allowed):

Category I	$e \leq 3,5$ mm
Category II	$3,5 \text{ mm} < e \leq 4,5$ mm
Category III	$4,5 \text{ mm} < e \leq 6,5$ mm
Category IV	$6,5 \text{ mm} < e$.

1.2. **The secondary characteristics are as follows:—**

1.2.1. Nature of the material (polished (plate) glass, float glass, sheet glass);

1.2.2. Colouring (colourless or tinted);

1.2.3. The incorporation or otherwise of conductors.

1.2.4. The incorporation or otherwise of obscuration bands.

2. FRAGMENTATION TEST

2.1. **Index of difficulty of the secondary characteristics**

Material	Index of difficulty
Plate glass	2
Float glass	1
Sheet glass	1

No other secondary characteristics are involved.

2.2. **Selection of Samples**

2.2.1. Four samples shall be tested.

⁽¹⁾ This type of uniformly-toughened glass pane can also be used for windscreens for slow-moving vehicles which, by construction, cannot exceed 40 km/h.

2.3. **Test Method**

2.3.1. The method used shall be that described in Annex 3, Paragraph 1.

2.4. **Point of impact**

2.4.1. The sample will be broken at its geometric centre (see Annex 16).

2.5. **Interpretation of Results**

2.5.1. A test shall be deemed to have given a satisfactory result if fragmentation satisfies the following conditions:—

2.5.1.1. The number of fragments in any 5 cm x 5 cm square is not less than 40.

2.5.1.2. For the purposes of the above rule, a fragment extending across a side of a square shall count as half a fragment.

2.5.1.3. Fragmentation shall not be checked in a strip 2 cm wide round the edge of the samples, this strip representing the frame of the glass; nor within a radius of 7,5 cm from the point of impact.

When a fragment extends beyond the excluded area only the part of the fragment falling outside of the area shall be assessed.

2.5.1.4. The weight of the largest crack free fragment shall not exceed the limits specified below except in the areas defined in Paragraph 2.5.1.3 above.

Thickness Category	Weight of the Largest Crack Free Fragment
Categories I and II	≤ 3,0 g
Categories III and IV	≤ 4,3 g

2.5.1.5. No fragment longer than 10 cm in length shall be allowed except in the areas defined in Paragraph 2.5.1.3 above.

2.5.2. A set of samples shall be considered acceptable if at least three of the four tests give a satisfactory result.

3. MECHANICAL STRENGTH TEST

3.1. **227 g ball test**

3.1.1. *Indices of difficulty of the secondary characteristics*

Material	Index of Difficulty	Colouring	Index of Difficulty
Polished Glass	2	colourless	1
Float Glass	1	tinted	2
Sheet Glass	1		

The other secondary characteristics (namely, incorporation or otherwise of conductors) is not involved.

3.1.2. *Number of Test Pieces*

Six test pieces shall be subjected to testing for each thickness category defined in Paragraph 1.1.4. above.

3.1.3. *Test Method*

3.1.3.1. The test method used shall be that described in Annex 3, Paragraph 2.1.

3.1.3.2. The height of drop (from the underface of the ball to the upper surface of the test piece) shall be:

	+ 5 mm
2,0 m	- 0 mm

3.1.4. *Interpretation of Results*

3.1.4.1. The test shall be deemed to have given a satisfactory result if the test piece does not break.

3.1.4.2. A set of test pieces shall be considered acceptable if at least five of the six tests give a satisfactory result.

4. OPTICAL QUALITIES

4.1. The provisions concerning regular light transmittance set out in Annex 3, Paragraph 9.1., shall apply to uniformly-toughened glass panes or parts of glass panes other than windscreens located at places which are essential to the driver vision.

4.2. The provisions of Paragraph 9 of Annex 3 shall apply to uniformly-toughened glass panes used as windscreens of slow-moving vehicles which, by construction, cannot exceed 40 km/h.

ANNEX 6

ORDINARY LAMINATED-GLASS WINDSCREENS

1. DEFINITION OF TYPE

Ordinary laminated-glass windscreens shall be deemed to belong to different types if they differ in at least one of the following principal or secondary characteristics:-

1.1. The principal characteristics are as follows:—

1.1.1. The manufacturer's trade name or marks;

1.1.2. The shape and dimensions.

Ordinary laminated-glass windscreens shall be deemed to belong to one group for the purposes of tests of mechanical properties and of resistance to the environment;

1.1.3. The number of layers of glass;

1.1.4. The nominal thickness 'e' of the windscreen, a manufacturing tolerance of 0,2 n mm ('n' being the number of layers of glass in the windscreen) above or below the nominal value being allowed;

1.1.5. The nominal thickness of the interlayer or interlayers;

1.1.6. The nature and type of the interlayer or interlayers (e.g., PVB or other plastics material interlayer or interlayers).

1.2. The secondary characteristics are as follows:—

1.2.1. The nature of the material (polished (plate) glass, float glass, sheet glass);

1.2.2. The colouring (total or partial) of the interlayer or interlayers (colourless or tinted);

1.2.3. The colouring of the glass (colourless or tinted);

1.2.4. The incorporation or otherwise of conductors;

1.2.5. The incorporation or otherwise of obscuration bands.

2. GENERAL

2.1. In the case of ordinary laminated-glass windscreens, tests other than headform tests (Paragraph 3.2. below) and tests of optical qualities shall be conducted on flat test pieces which are either cut from actual windscreens or are specially made for the purpose. In either case the test pieces shall be in all respects rigorously representative of the serially-produced windscreens.

2.2. Before each test the test pieces shall be stored for not less than four hours at a temperature of $23^{\circ} \pm 2^{\circ}\text{C}$. The tests shall take place as soon as possible after the test pieces have been taken out of the receptacle in which they were stored.

3. HEADFORM TEST

3.1. Indices of difficulty of the secondary characteristics

No secondary characteristic is involved.

3.2. **Headform test on a complete windscreen**

3.2.1. Number of samples

Four windscreens shall be tested.

3.2.2. Test method

3.2.2.1. The method used shall be that described in Annex 3, Paragraph 3.1.

3.2.2.2. The drop height shall be 1,5 m $\begin{matrix} + 10 \\ - 5 \text{ mm.} \end{matrix}$

3.2.3. Interpretation of results

3.2.3.1. This test shall be deemed to have given a satisfactory result if the following conditions are fulfilled:—

3.2.3.1.1. The sample breaks displaying numerous circular cracks centred approximately on the point of impact, the cracks nearest to the point of impact being not more than 80 mm from it.

3.2.3.1.2. The layer of glass shall remain adhering to the plastics-material interlayer. One or more partial separation from the interlayer with a distance of less than 4 mm in breadth, on either side of the crack, is permitted outside a circle of 60 mm diameter centred on the point of impact.

3.2.3.1.3. On the impact side:—

3.2.3.1.3.1. The interlayer must not be laid bare over an area of more than 20 cm².

3.2.3.1.3.2. A tear in the interlayer up to a length of 35 mm is allowed.

3.2.3.2. A set of samples shall be considered acceptable if at least three of the four tests give a satisfactory result.

4. MECHANICAL STRENGTH TEST

4.1. **Indices of difficulty of the secondary characteristics**

No secondary characteristic is involved.

4.2. **2,260 g ball test**

4.2.1. Number of test pieces

$\begin{matrix} + 10 \\ - 0 \text{ mm side} \end{matrix}$
Six square test pieces of 300 mm side shall be subjected to testing.

4.2.2. *Test method*

4.2.2.1. The method used shall be that described in Annex 3, Paragraph 2.2.

4.2.2.2. The height of drop (from the underface of the ball to the upper face of the test piece) shall be $\begin{matrix} + 25 \\ - 0 \text{ mm.} \end{matrix}$

4.2.3. *Interpretation of results*

4.2.3.1. The test shall be deemed to have given a satisfactory result if the ball does not pass through the glazing within five seconds after the moment of impact.

4.2.3.2. A set of test pieces shall be considered acceptable if five of the six tests carried out give a satisfactory result.

4.3. **227 g ball test**

4.3.1. *Indices of difficulty of the secondary characteristics*

No secondary characteristic is involved.

4.3.2. Number of test pieces

+ 10

Twenty square test pieces of 300 - 0 mm side shall be subjected to testing.

4.3.3. *Test method*

4.3.3.1. The method used shall be that described in Annex 3, Paragraph 2.1. Ten specimens shall be tested at a temperature of + 40°C ± 2°C and ten at a temperature of - 20°C ± 2°C.

4.3.3.2. The height of drop for the various thickness categories and the mass of the detached fragments are given in the table below:—

Thickness of Test Piece	+ 40°C		- 20°C	
	Height of Fall	Maximum Permitted Mass of the Fragments	Height of Fall	Maximum Permitted Mass of the Fragments
mm	m ^(*)	g	m ^(*)	g
e ≤ 4,5	9	12	8,5	12
4,5 < e ≤ 5,5	9	15	8,5	15
5,5 < e ≤ 6,5	9	20	8,5	20
e > 6,5	9	25	8,5	25

4.3.4. *Interpretation of results*

4.3.4.1. The test shall be considered to have given a satisfactory result if the following conditions are met:

The ball does not pass through the test piece,

The test piece does not break into several pieces,

If the interlayer is not torn, the weight of fragments detached from the side of the glass opposite to the point of impact must not exceed the appropriate values specified in Paragraph 4.3.3.2. above.

4.3.4.2. A set of test pieces shall be considered acceptable if at least eight of the ten tests at each test temperature give a satisfactory result.

5. **TEST OF RESISTANCE TO THE ENVIRONMENT**

5.1. **Test of Resistance to Abrasion**

5.1.1. *Indices of difficulty and test method*

The requirements of Annex 3, Paragraph 4, shall apply, the test being continued for 1 000 cycles.

(*) + 25
A tolerance of - 0 mm is allowed in height of fall.

5.1.2. *Interpretation of results*

The safety-glass pane shall be considered satisfactory with respect to abrasion resistance if the light scatter as a result of abrasion of the test piece does not exceed 2%.

5.2. **Test of resistance to high temperature**

The requirements of Annex 3, Paragraph 5, shall apply.

5.3. **Resistance-to-radiation test**

The requirements of Annex 3, Paragraph 6.3, shall apply.

5.4. **Resistance-to-humidity test**

The requirements of Annex 3, Paragraph 7, shall apply.

6. OPTICAL QUALITIES

The requirements concerning optical qualities set out in Annex 3, Paragraph 9, shall apply to each windscreen type.

ANNEX 7

LAMINATED-GLASS PANES OTHER THAN WINDSCREENS

1. DEFINITION OF TYPE

Laminated-glass panes other than windscreens shall be deemed to belong to different types if they differ in at least one of the following principal or secondary characteristics.

1.1. The principal characteristics are as follows :—

1.1.1. The manufacturer's trade names or marks;

1.1.2. The thickness category of the pane in which the nominal thickness 'e' lies, a manufacturing tolerance of $\pm 0,2$ n mm ('n' being the number of layers of glass in the pane) being allowed:-

Category I	$e \leq 5,5$ mm
Category II	$5,5 \text{ mm} < e \leq 6,5$ mm
Category III	$6,5 \text{ mm} < e$

1.1.3. The nominal thickness of the interlayer or interlayers;

1.1.4. The nature and type of the interlayer or interlayers, e.g. PVB or other plastics-material interlayer or interlayers;

1.1.5. Any special treatment which one of the layers of glass may have undergone.

1.2. The secondary characteristics are as follows :—

1.2.1. The nature of the material (polished (plate) glass, float glass, sheet glass);

1.2.2. The colouring (total or partial) of the interlayer or interlayers (colourless or tinted);

1.2.3. The colouring of the glass (colourless or tinted).

1.2.4. The incorporation or otherwise of obscuration bands.

2. GENERAL

2.1. In the case of laminated-glass panes other than windscreens, the tests shall be conducted on flat test pieces which are either cut from actual glass panes or are specially made. If the laminated glass panes are made from one or more treated glass layers, finished products may be used for tests other than the headform test. Test pieces shall be in all respects rigorously representative of the glass panes being produced.

2.2. Before each test the test pieces of laminated-glass shall be stored for not less than four hours at a temperature of $23^{\circ}\text{C} \pm 2^{\circ}\text{C}$. The tests shall be performed on the test pieces as soon as the test pieces have been taken out of the receptacle in which they were stored.

3. HEADFORM TEST

3.1. Indices of difficulty of the secondary characteristics.

No secondary characteristics are involved.

3.2. Number of test pieces

Six flat test pieces measuring (1100 mm x 500 mm) (+25
- 0 mm) shall be subjected to testing.

3.3. Test method

3.3.1. The method used shall be that described in Annex 3, Paragraph 3.1.

3.3.2. The height of drop shall be 1,50 m + 0
- 5 mm.

3.4. Interpretation of results.

3.4.1. This test shall be deemed to have given a satisfactory result if the following conditions are met:—

3.4.1.1. The test piece yields and breaks, displaying numerous circular cracks centred approximately on the point of impact;

3.4.1.2. Tears in the interlayer are allowed, but the manikin head must not pass through;

3.4.1.3. No large fragments of glass shall become detached from the interlayer.

3.4.2. A set of test pieces shall be considered acceptable if at least five of the six tests give a satisfactory result.

4. MECHANICAL STRENGTH TEST — 227 g BALL TEST

4.1. Indices of difficulty of the secondary characteristics

No secondary characteristic is involved.

4.2. Number of test pieces

Four flat square test pieces of (300 mm x 300 mm) (+ 10
- 0 mm) side or four finished products shall be subjected to testing.

4.3. Test method

4.3.1. The method used shall be that described in Annex 3, Paragraph 2.1.

4.3.2. The height of drop from the underface of the ball to the upper face of the test piece or finished part shall be as indicated in the following table as a function of nominal thickness:—

Nominal Thickness	Height of Drop
$e \leq 5,5 \text{ mm}$	5 m
$5,5 \text{ mm} < e \leq 6,5 \text{ mm}$	6 m + 25 - 0 mm
$6,5 \text{ mm} < e$	7 m

4.4. **Interpretation of results**

4.4.1. The test shall be considered to have given a satisfactory result if the following conditions are met:—

The ball does not pass through the test piece or finished part,

The laminate does not break into several fragments,

The total weight of the few fragments which may be produced on the side opposite to the point of impact does not exceed 15 g.

4.4.2. A set of test pieces or finished products shall be considered acceptable if at least three of the four tests give a satisfactory result.

5. **TEST OF RESISTANCE TO THE ENVIRONMENT**

5.1. **Test of Resistance to Abrasion**

5.1.1. *Indices of difficulty and test method*

The requirements of Annex 3, Paragraph 4, shall apply, the test being continued for 1 000 cycles.

5.1.2. *Interpretation of results*

The safety glazing material shall be considered acceptable if the light scatter as a result of abrasion on three test pieces does not exceed 2%.

5.2. **Test of resistance to high temperature**

The requirements of Annex 3, Paragraph 5, shall apply.

5.3. **Resistance-to-Radiation Test**

5.3.1. *General requirement*

This test shall be performed only if the laboratory deems it useful in the light of the information in its possession concerning the interlayer.

5.3.2. *Number of samples or test pieces*

The requirements of Annex 3, Paragraph 6.3, shall apply.

5.4. **Resistance-to-Humidity test**

The requirements of Annex 3, Paragraph 7, shall apply.

6. OPTICAL QUALITIES

The provisions concerning the regular light transmittance set out in Annex 3, Paragraph 9.1., shall apply to glass panes other than windscreens, or parts of glass panes other than windscreens, located at places requisite for driver visibility.

ANNEX 8

TREATED LAMINATED-GLASS WINDSCREENS

1. DEFINITION OF TYPE

Treated laminated-glass windscreens shall be deemed to belong to different types if they differ in at least one of the following principal or secondary characteristics.

1.1. The principal characteristics are as follows:—

1.1.1. The manufacturer's trade name or marks;

1.1.2. The shape and dimensions.

Treated laminated-glass windscreens shall be deemed to belong to one group for the purposes of tests of fragmentation, of mechanical properties and of resistance to the environment;

1.1.3. The number of layers of glass;

1.1.4. The nominal thickness 'e' of the windscreen, a manufacturing tolerance of 0,2 n mm ('n' being the number of layers of glass in the windscreen) above and below the nominal value being allowed;

1.1.5. Any special treatment which one or more layers of glass may have undergone;

1.1.6. The nominal thickness of the interlayer or interlayers;

1.1.7. The nature and type of the interlayer or interlayers (e.g. PVB or other plastics-material interlayer or interlayers).

1.2. **The secondary characteristics are as follows :—**

1.2.1. The nature of the material (polished (plate) glass, float glass, sheet glass);

1.2.2. The colouring (total or partial) of the interlayer or interlayers (colourless or tinted);

1.2.3. The colouring of the glass (colourless or tinted);

1.2.4. The incorporation or otherwise of conductors;

1.2.5. The incorporation or otherwise of obscuration bands.

2. GENERAL

2.1. In the case of treated laminated-glass windscreens, tests other than the headform test on a complete windscreen and tests of optical qualities shall be conducted on samples and/or flat test pieces which are specially made for the purpose. However, the test pieces shall be in all respects rigorously representative of the serially-produced windscreens.

2.2. Before each test, the test pieces or samples shall be stored for not less than four hours at a temperature of $23^{\circ}\text{C} \pm 2^{\circ}\text{C}$. The tests shall take place as soon as possible after the test pieces or samples have been taken out of the receptacle in which they were stored.

3. TESTS PRESCRIBED

Treated laminated-glass windscreens shall be subjected to:—

- 3.1. The tests prescribed in Annex 6 for ordinary laminated-glass windscreens,
- 3.2. The fragmentation test described in Paragraph 4 below.

4. FRAGMENTATION TEST

4.1. Indices of difficulty of the secondary characteristics

MATERIAL	INDEX OF DIFFICULTY
Plate glass	2
Float glass	1
Sheet glass	1

4.2. Number of test pieces or samples

+ 5

Four test pieces measuring (1100 mm x 500 mm) - 2 mm or one sample for each point of impact shall be subjected to testing.

4.3. Test method

The method used shall be that described in Annex 3, Paragraph 1.

4.4. Impact point

The test piece or sample shall be broken on the outer treated sheet at its geometric centre.

4.5. Interpretation of results

4.5.1. The fragmentation test shall be considered to have given a satisfactory result if the total surface area of fragments having a surface area of more than 2 cm² comprised in a rectangle as defined in Annex 4, Paragraph 2.3.2., represents not less than 15 per cent of the surface of that rectangle.

4.5.1.1. In the case of a sample:—

4.5.1.1.1. For [vehicles of Category M₁], the centre of the rectangle shall be situated within a circle having a radius of 10 cm centred on the projection of the middle of segment V₁ V₂.

4.5.1.1.2. For [vehicles of Categories M and N other than M₁], the centre of the rectangle shall be situated within a circle having a radius of 10 cm centred on the projection of point O.

4.5.1.1.3. For agricultural and forestry tractors and for construction-site vehicles, the position of the visibility zone shall be indicated in the test report.

4.5.1.1.4. The height of the above rectangle may be reduced to 15 cm for windscreens which are less than 44 cm high or whose angle of installation is less than 15° from the vertical; the percentage of visibility shall at least be equal to 10 per cent of the area of the corresponding rectangle.

- 4.5.1.2. In the case of a test piece, the centre of the rectangle shall be situated on the greater axis of the test piece at 450 mm from one of its edges.
- 4.5.2. The set of test pieces or samples shall be considered acceptable if at least three of the four tests give a satisfactory result.

ANNEX 9

SAFETY-GLASS PANES FACED WITH PLASTICS MATERIAL

(on the inner face)

1. DEFINITION OF TYPE

Safety glazing materials, as defined in Annex 4 to 8, if coated on the inner face with a layer of plastics material, shall conform not only to the requirements of the appropriate annexes but also to the following requirements.

2. TEST OF RESISTANCE TO ABRASION

2.1. Indices of difficulty and test method

The plastics coating shall be subjected to a test for 100 cycles in accordance with the requirements specified in Annex 3, Paragraph 4.

2.2. Interpretation of results

The plastics coating shall be considered satisfactory with respect to abrasion resistance if the light scatter as a result of abrasion of the test piece does not exceed 4%.

3. RESISTANCE-TO-HUMIDITY TEST

3.1. In the case of plastics-coated toughened safety glazing material a resistance-to-humidity test shall be performed.

3.2. The requirements of Annex 3, Paragraph 7, shall apply.

4. TEST OF RESISTANCE TO TEMPERATURE CHANGES

The requirements of Annex 3, Paragraph 8, shall apply.

5. FIRE-RESISTANCE TEST

The requirements of Annex 3, Paragraph 10, shall apply.

6. TEST OF RESISTANCE TO CHEMICALS

The requirements of Annex 3, Paragraph 11, shall apply.

ANNEX 10

GLASS-PLASTICS WINDSCREENS

1. DEFINITION OF TYPE

Glass-plastics windscreens shall be considered to belong to different types if they differ in at least one of the following principal or secondary characteristics.

1.1. The principal characteristics are as follows:

1.1.1. The manufacturer's trade name or marks,

1.1.2. The shape and dimensions.

Glass-plastics windscreens shall be deemed to belong to a group for the purposes of tests of mechanical strength, resistance to the environment, resistance to temperature changes and resistance to chemical agents,

1.1.3. The number of plastics layers,

1.1.4. The nominal thickness of the windscreen, a manufacturing tolerance of $\pm 0,2$ mm being allowed,

1.1.5. The nominal thickness of the layer of glass,

1.1.6. The nominal thickness of the layer(s) of plastics acting as interlayer(s),

1.1.7. The nature and type of the layer(s) of plastics acting as interlayer(s) (e.g. PVB or other material) and of the plastics layer situated on the inner face,

1.1.8. Any special treatment the glass pane may have undergone.

1.2. The secondary characteristics are as follows :—

1.2.1. The nature of the material (plate glass, float glass, sheet glass)

1.2.2. The colouring (total or partial) of any layer(s) of plastics (colourless or tinted),

1.2.3. The colouring of the glass (colourless or tinted),

1.2.4. The incorporation or otherwise of conductors,

1.2.5. The incorporation or otherwise of obscuration bands.

2. GENERAL

2.1. In the case of glass-plastics windscreens, tests other than headform tests (Paragraph 3.2.) and tests of optical qualities shall be conducted on flat test pieces which are either cut from actual windscreens or are specially made for the purpose. In either case the test pieces shall in all respects be rigorously representative of the serially-produced windscreens.

2.2. Before each test, the test pieces shall be stored for not less than four hours at a temperature of $23^{\circ}\text{C} \pm 2^{\circ}\text{C}$. The tests shall take place as soon as possible after the test pieces have been taken out of the receptacle in which they were stored.

3. HEADFORM TEST

3.1. Indices of difficulty of the secondary characteristics

No secondary characteristic is involved.

3.2. **Headform test on a complete windscreen**

3.2.1. *Number of samples*

Four samples from the series having the smallest developed area and four samples from the series having the largest developed area, selected in accordance with the provisions of Annex 13, shall be tested.

3.2.2. *Test method*

3.2.2.1. The method used shall be that described in Annex 3, Paragraph 3.1.

3.2.2.2. The height of drop shall be 1.50 m $\begin{matrix} + 0 \\ - 5 \text{ mm} \end{matrix}$.

3.2.3. *Interpretation of results*

3.2.3.1. This test shall be considered to have given a satisfactory result if the following conditions are met.

3.2.3.1.1. The layer of glass breaks, displaying numerous circular cracks centred approximately on the point of impact, the cracks nearest to the point of impact being not more than 80 mm from it;

3.2.3.1.2. The layer of glass remains adhering to the plastics material interlayer. One or more partial separations from the interlayer not more than 4 mm in breadth may be allowed on either side of the crack outside a circle 60 mm in diameter centred on the point of impact;

3.2.3.1.3. A tear in the interlayer of a length up to 35 mm is allowed on the impact side.

3.2.3.2. A set of samples shall be considered acceptable if at least three of the four tests give a satisfactory result.

3.3. **Headform test on flat test pieces**

3.3.1. *Number of test pieces*

Six flat test pieces measuring (1100 mm x 500 mm) $\begin{matrix} + 5 \\ - 2 \text{ mm} \end{matrix}$ shall be subjected to testing.

3.3.2. *Test method*

3.3.2.1. The method used shall be that described in Annex 3, Paragraph 3.1.

3.3.2.2. The height or drop shall be 4 m $\begin{matrix} + 25 \\ - 0 \text{ mm} \end{matrix}$.

3.3.3. *Interpretation of results*

3.3.3.1. This test shall be considered to have given a satisfactory result if the following conditions are met:—

3.3.3.1.1. The layer of glass yields and breaks, displaying numerous circular cracks centred approximately on the point of impact;

3.3.3.1.2. Tears in the interlayer are allowed, but the manikin head must not pass through;

3.3.3.1.3. No large fragment of glass shall become detached from the interlayer.

3.3.3.2. A set of test pieces shall be considered acceptable if at least five of the six tests give a satisfactory result.

4. MECHANICAL STRENGTH TEST

4.1. Indices of difficulty, test method and interpretation of results

The requirements of Annex 6, Paragraph 4, shall apply.

4.2. However the third requirement set out in Paragraph 4.3.4.1. of Annex 6 is not relevant.

5. TEST OF RESISTANCE TO THE ENVIRONMENT

5.1. Test of resistance to abrasion

5.1.1. Test of resistance to abrasion on the outer face.

5.1.1.1. The requirements of Annex 6, Paragraph 5.1., shall apply.

5.1.2. Test of resistance to abrasion on the inner face.

5.1.2.1. The requirements of Annex 9, Paragraph 2, shall apply.

5.2. Test of resistance to high temperature

The requirements of Annex 3, Paragraph 5, shall apply.

5.3. Resistance-to-radiation test

The requirements of Annex 3, Paragraph 6.3, shall apply.

5.4. Resistance-to-humidity test

The requirements of Annex 3, Paragraph 7, shall apply.

5.5. Test of resistance to temperature changes

The requirements of Annex 3, Paragraph 8, shall apply.

6. OPTICAL QUALITIES

The requirements concerning optical qualities set out in Annex 3, Paragraph 9, shall apply to each type of windscreen.

7. FIRE-RESISTANCE TEST

The requirements of Annex 3, Paragraph 10, shall apply.

8. TEST OF RESISTANCE TO CHEMICALS

The requirements of Annex 3, Paragraph 11, shall apply.

ANNEX 11

GLASS-PLASTICS PANES OTHER THAN WINDSCREENS

1. DEFINITION OF TYPE

Glass-plastics panes other than windscreens shall be considered to belong to different types if they differ in at least one of the following principal or secondary characteristics.

1.1. The principal characteristics are as follows:

1.1.1. The manufacturer's trade name or marks,

1.1.2. The thickness category applicable to the nominal thickness 'e' a manufacturing tolerance $\pm 0,2$ mm being allowed:

Category I		$e \leq 3,5$ mm
Category II	$3,5$ mm <	$e \leq 4,5$ mm
Category III	$4,5$ mm <	e

1.1.3. The nominal thickness of the layer(s) of plastics material acting as interlayer(s),

1.1.4. The nominal thickness of the glass pane,

1.1.5. The type of the layer(s) of plastics material acting as interlayer(s) (e.g. PVB or other material) and of the plastics layer on the inner face,

1.1.6. Any special treatment which the layer of glass may have undergone.

1.2. The secondary characteristics are as follows:

1.2.1. The nature of the material (plate glass, float glass, sheet glass),

1.2.2. The colouring (total or partial) of any layer(s) of plastics (colourless or tinted),

1.2.3. The colouring of the glass (colourless or tinted).

1.2.4. The incorporation or otherwise of obscuration bands.

2. GENERAL

2.1. In the case of glass-plastics panes other than windscreens the tests shall be conducted on flat test pieces which are either cut from normal glass panes or are specially made. In either case the test pieces shall be in all respects rigorously representative of the glass - plastic panes manufactured.

2.2. Before each test, the test pieces of glass-plastics panes shall be stored for not less than four hours at a temperature of $23^{\circ}\text{C} \pm 2^{\circ}\text{C}$. The tests shall take place as soon as possible after the test pieces have been taken out of the receptacle in which they were stored.

3. HEADFORM TEST

3.1. Indices of difficulty of the secondary characteristics

No secondary characteristic is involved.

3.2. Number of test pieces

Six flat test pieces measuring (1100 mm x 500 mm) $+5$
- 0 mm shall be subjected to testing.

3.3. Test method

3.3.1. The method used shall be that described in Annex 3, Paragraph 3.1.

3.3.2. The height of drop shall be 1,50 m $+0$
- 5 mm.

3.4. Interpretation of results

3.4.1. This test shall be considered to have given a satisfactory result if the following conditions are met:—

3.4.1.1. The layer of glass breaks, displaying numerous cracks;

3.4.1.2. Tears in the interlayer are allowed, provided that the manikin head does not pass through the test piece;

3.4.1.3. No large fragment of glass shall become detached from the interlayer.

3.4.2. A set of test pieces shall be considered acceptable if at least five of the six tests give a satisfactory result.

4. MECHANICAL STRENGTH TEST — 227 g BALL TEST

4.1. The provisions of Annex 7, Paragraph 4, shall apply, with the exception of the table in Paragraph 4.3.2., to be replaced by:

Nominal thickness	Height of drop
$e \leq 3,5 \text{ mm}$	5 m)
$3.5 \text{ mm} < e \leq 4,5 \text{ mm}$	6 m) + 25
$e > 4,5 \text{ mm}$	7 m) - 0 mm

4.2. However the third requirement set out in Paragraph 4.4.1. of Annex 7 is not relevant.

5. TEST OF RESISTANCE TO THE ENVIRONMENT

5.1. Test of resistance to abrasion

5.1.1. Test of resistance to abrasion on the outer face. The requirements of Annex 7, Paragraph 5.1., shall apply.

5.1.2. Test of resistance to abrasion on the inner face. The requirements of Annex 9, Paragraph 2.1., shall apply.

5.2. Test of resistance to high temperature

The requirements of Annex 3, Paragraph 5, shall apply.

5.3. Resistance-to-radiation test

The requirements of Annex 3, Paragraph 6.3, shall apply.

5.4. Resistance-to-humidity test

The requirements of Annex 3, Paragraph 7, shall apply.

5.5. Test of resistance to temperature changes

The requirements of Annex 3, Paragraph 8, shall apply.

6. OPTICAL QUALITIES

The provisions concerning the regular light transmittance set out in Annex 3, Paragraph 9.1., shall apply to glass panes or parts of glass panes other than windscreens located at places which are essential to the driver's vision.

7. FIRE-RESISTANCE TEST

The requirements of Annex 3, Paragraph 10, shall apply.

8. TEST OF RESISTANCE TO CHEMICALS

The requirements of Annex 3, Paragraph 11, shall apply.

ANNEX 12

DOUBLE-GLAZED UNITS

1. DEFINITION OF TYPE

Double-glazed units shall be considered to belong to different types if they differ in at least one of the following principal or secondary characteristics.

1.1. The principal characteristics are as follows:

1.1.1. The manufacturer's trade name or marks,

1.1.2. The composition of the double-glazed unit (symmetrical, asymmetrical),

1.1.3. The type of each component glass pane as defined in Paragraph 1 of Annexes 5, 7 or 11 to this Regulation,

1.1.4. The nominal width of the gap between the two glass panes,

1.1.5. The type of sealing.

1.2. The secondary characteristics are:

1.2.1. The secondary characteristics of each component glass pane, as defined in Paragraph 1.2. of Annexes 5, 7 or 11 to this Regulation.

2. GENERAL

2.1. Each component glass pane forming the double-glazed unit subjected to the requirements set out in the relevant annex to this Regulation (Annexes 5, 7 or 11).

2.2. Tests carried out on double-glazed units having a nominal width of gap 'e' shall be considered to be applicable to all double-glazed units having the same characteristics and a nominal width of gap $e \pm 3$ mm.

2.3. In the case of double-glazed units having at least one laminated glass pane or one glass-plastics pane, the test pieces shall be stored for at least four hours prior to the test at a temperature of $23^{\circ}\text{C} \pm 2^{\circ}\text{C}$. The tests shall take place immediately after the test pieces are taken out of the receptacle in which they were stored.

3. HEADFORM TEST

3.1. Index of difficulty of the secondary characteristics

No secondary characteristic is involved.

3.2. Number of test pieces

Six test pieces (1100 mm x 500 mm) $+ 5$
- 2 mm shall be subjected to testing for each category of thickness of the component glass panes and each width of gap as defined in paragraph 1.1.4. above.

3.3. **Test method**

3.3.1. The method used shall be that described in Annex 3, Paragraph 3.1.

3.3.2. The height of drop shall be 1,50 m $\begin{matrix} + 0 \\ - 5 \text{ mm.} \end{matrix}$

3.3.3. In the case of an asymmetrical double-glazed unit, three tests shall be carried out on one side and three tests on the other side.

3.4. **Interpretation of results**

3.4.1. Double glazing consisting of two uniformly-toughened glass panes:

The test shall be considered to have given a satisfactory result if both components break;

3.4.2. Double glazing consisting of laminated glass panes and/or glass-plastics panes other than windscreens:

The test shall be considered to have given a satisfactory result if the following conditions are met:

3.4.2.1. The two components of the test piece yield and break, displaying numerous circular cracks centred approximately on the point of impact;

3.4.2.2. Tears in the interlayer(s) are allowed provided that the manikin head does not pass through the test piece;

3.4.2.3. No large fragment of glass becomes detached from the interlayer.

3.4.3. Double glazing consisting of a uniformly-toughened glass pane and of a laminated glass pane or glass-plastics pane other than windscreens:

3.4.3.1. The toughened-glass pane breaks;

3.4.3.2. The laminated glass pane or glass-plastics pane yields and breaks, displaying numerous circular cracks centred approximately on the point of impact;

3.4.3.3. Tears in the interlayer(s) are allowed provided that the manikin head does not pass through the test piece;

3.4.3.4. No large fragment of glass becomes detached from the interlayer.

3.4.4. A set of test pieces shall be considered acceptable if at least five of the six tests give a satisfactory result.

4. OPTICAL QUALITIES

The provisions concerning the regular light transmittance set out in Annex 3, Paragraph 9.1., shall apply to double glazed units or parts of double-glazed units located at places which are essential to the driver's vision.

ANNEX 13

RIGID PLASTIC GLAZINGS OTHER THAN WINDSCREENS

1. DEFINITION OF TYPE

Rigid plastic glazings shall be considered to belong to different types if they differ in at least one of the following principal or secondary characteristics.

1.1. The principle characteristics are as follows:

1.1.1. The manufacturer's trade name or marks;

1.1.2. The chemical designation of the material.

1.1.3. The classification of the material by the manufacturer.

1.1.4. The process of manufacture.

1.1.5. The shape and dimensions.

1.1.6. The nominal thickness. The thickness tolerance limit for extruded plastic products is $\pm 10\%$ of the nominal thickness. For plastic products produced by other techniques (e.g. cast acrylic sheet), the acceptable thickness tolerance is given by the equation (thickness tolerance limits (mm) = $\pm (0.4 + 0.1 e)$ where e is the sheet thickness in millimetres. Reference standard is ISO 7823/1.

1.1.7. The colouring of the plastic product.

1.1.8. The nature of the surface coating.

1.2. The secondary characteristics are as follows:

1.2.1. The presence or absence of conductors or heating elements.

2. GENERAL

2.1. In the case of rigid plastic panes the tests shall be conducted either on flat test pieces rigorously representative of the finished product or on finished parts. All optical measurements shall be carried out on real parts.

2.2. The test pieces must be freed from protecting maskings and have to be cleaned carefully before the test.

2.2.1. They must be stored for 48 hours at a temperature of $23^{\circ}\text{C} \pm 2^{\circ}\text{C}$ and a relative humidity of $50\% \pm 5\%$.

2.3. To describe the breaking behaviour under dynamical stress, classes will be created depending on the application of the plastics. These classes are related to contact probabilities of the human head with the plastic glazing and they contain different requirements concerning the headform test.

3. **FLEXIBILITY TEST**

3.1. **Indices of difficulty of the secondary characteristics**

No secondary characteristic is involved.

3.2. **Number of test pieces**

One flat test piece measuring 300 mm x 25 mm shall be subjected to testing.

3.3. **Test method**

3.3.1. The method used shall be that described in Annex 3 Paragraph 12.

3.4. **Interpretation of results**

For a test piece or sample to be considered rigid the vertical deflection of the test piece shall be less than or equal to 50 mm after 60 seconds.

4. **HEADFORM TEST**

4.1. **Indices of difficulty of the secondary characteristics**

No secondary characteristic is involved.

4.2. **Number of test pieces**

Six flat test pieces (1170 x 570 + 0/- 2 mm) or six complete parts shall be subjected to testing.

4.3. **Test method**

4.3.1. The method used shall be that described in Annex 3 Paragraph 3.2.

4.3.2. For panes like partitions, separating and side windows (classification VIII/A) the drop height shall be 3 m. The HIC value is also to be measured.

4.3.3. For panes which do not have contact possibilities as well as for small windows in vehicles and for all windows in trailers (classification VIII/B) there will be no headform testing. A small window is a window into which a 150 mm diameter circle cannot be scribed.

4.4. **Interpretation of results**

The test shall be deemed to have given a satisfactory result if the following conditions are fulfilled:

4.4.1. The test piece or sample is not penetrated nor shall it break into fully separate large pieces.

4.4.2. The HIC value is less than 1000.

4.4.3. A set of test pieces or samples shall be considered acceptable if all the tests give a satisfactory result.

5. **MECHANICAL STRENGTH TEST 227 g BALL TEST**

5.1. **Indices of difficulty of the secondary characteristics:**

- 1: without conductors or heating elements
- 2: with conductors or heating elements

5.2. **Number of test pieces**

Ten flat square pieces $300 \pm 10 / - 0$ mm or ten substantially flat finished parts shall be subjected to testing.

5.3. **Test method**

5.3.1. The method used shall be that prescribed in Annex 3, Paragraph 2.1.

5.3.2. The height of drop for the various thickness values is given in the table below:

sheet thickness (mm)	height of drop (m)
< 3	2
4	3
5	4
> 6	5

For intermediate values of test piece thickness in the interval between 3 mm and 6 mm the height of drop must be interpolated.

5.4. **Interpretation of results**

5.4.1. The ball test shall be considered to have given a satisfactory result if the following conditions are met:

- the ball does not penetrate the test piece
- the test piece does not break into separate pieces

As a result of the impact, cracks and fissures in the sheet are however permissible.

5.4.2. A set of test pieces shall be considered acceptable if at least eight of the ten tests give a satisfactory result.

5.5. **227 g ball test at $-20^{\circ}\text{C} \pm 2^{\circ}\text{C}$**

5.5.1. To minimize the temperature change of the test piece, the test shall be performed within 30 seconds of the removal of the test piece from the conditioning appliance.

5.5.2. The test method shall be that described in Paragraph 5.3 of this annex, except that the test temperature is $-20^{\circ}\text{C} \pm 2^{\circ}\text{C}$.

5.5.3. Interpretation of results as in Paragraph 5.4 of this annex.

6. **TEST RESISTANCE TO THE ENVIRONMENT**

6.1. **Test of resistance to abrasion**

6.1.1. *Indices of difficulty and test method*

The requirements of Annex 3, Paragraph 4 shall apply; the test is performed for either 1000, 500 or 100 cycles to measure abrasion of the surface of the product.

6.1.2. Three flat square test pieces of 100 mm for each type of surface shall be subjected to testing.

6.1.3. *Interpretation of results*

6.1.3.1. For safety glazings used at places which are requisite for the driver visibility, the abrasion test shall be considered to have given a satisfactory result if the total light scatter after abrasion does not exceed 2% after 1000 cycles on the outer surface of the test piece and 4% after 100 cycles on the inner surface of the test piece.

6.1.3.2. For side glazings used at places which are not requisite for the driver visibility, the abrasion test shall be considered to have given a satisfactory result if the total light scatter after abrasion does not exceed 10% after 500 cycles on the outer surface and 4% after 100 cycles on the inner surface.

6.1.3.3. No abrasion testing is requisite for rigid plastic glazings for trailers and for motor caravans with a gross vehicle mass greater than 2 500 kgs.

6.1.4. A set of samples shall be considered acceptable if all the tests give a satisfactory result.

6.2. **Test of resistance to simulated weathering**

6.2.1. *Indices of difficulty and test method*

The requirements of Annex 3, Paragraph 6.4 shall apply. The total ultraviolet radiant exposure with the long arc Xenon lamp shall be 500 MJ/m². During irradiation the test pieces shall be exposed to water spray in continuous cycles. During a cycle of 120 minutes the test pieces are exposed to light without water spray for 102 minutes, and to light with water spray for 18 minutes.

6.2.1.1. Other methods giving equivalent results shall be allowed.

6.2.2. *Number of test pieces*

Three flat test pieces 130 x 40 mm cut from a flat sheet sample shall be subjected to testing.

6.2.3. *Interpretation of results*

6.2.3.1. The resistance to the simulated weathering shall be considered to have given a satisfactory result if:

6.2.3.1.1. The light transmittance measured in accordance with Annex 3, Paragraph 9.1 does not fall below 95% of the pre-weathering value. Additionally, for windows which are required for driver visibility the value shall not fall below 70%.

6.2.3.1.2. No bubbles or other visible decompositions, discolourations, milkiness or crazing shall occur during weathering.

6.2.4. A set of test pieces shall be considered acceptable if all the tests give a satisfactory result.

6.3. **Cross-cut test**

6.3.1. *Indices of difficulty and test method*

The requirements of Annex 3, Paragraph 13 shall apply only to coated rigid products.

6.3.2. The cross-cut test shall be carried out on one of the test pieces from 6.2.

6.3.3. *Interpretation of results*

6.3.3.1. The cross-cut test shall be considered to have given a satisfactory result if the cross-cut value Gt 1 is met.

6.4. **Resistance-to-humidity test**

6.4.1. *Indices of difficulty and test method*

The requirements of Annex 3, Paragraph 7 shall apply.

6.4.2. Ten flat square test pieces of 300 mm shall be subjected to testing.

6.4.3. *Interpretation of results*

6.4.3.1. The humidity test shall be considered to have given a satisfactory result if:

6.4.3.1.1. No visible decompositions like bubbles or milkiness occur on any sample,

6.4.3.1.2. and if the light transmittance measured according to Annex 3, Paragraph 9.1 does not fall to less than 95% of the pre-test value and additionally to no less than 70% for any window required for driver visibility.

6.4.4. After testing the test pieces shall be stored for at least 48 hours at a temperature of $23^{\circ}\text{C} \pm 2^{\circ}\text{C}$ and a relative humidity of $50\% \pm 5\%$, and then subjected to the 227 g ball drop test described under item 5 of this annex.

7. **OPTICAL QUALITIES**

The requirements of Annex 3, Paragraph 9.1 shall apply for products which are requisite for driver visibility.

7.1. *Interpretation of results*

A set of samples shall be considered acceptable if all the tests give a satisfactory result.

8. **FIRE RESISTANCE TEST**

8.1. **Indices of difficulty and test method**

The requirements of Annex 3, Paragraph 10 shall apply.

8.2. **Interpretation of results**

The fire-resistance test shall be considered to have given a satisfactory result if the burning rate is less than 90 mm/min.

8.2.1. A set of test pieces shall be considered acceptable if at least four of the five tests give a satisfactory result.

9. **RESISTANCE TO CHEMICALS**

9.1. **Indices of difficulty and test method**

The requirements of Annex 3, Paragraph 11 shall apply.

9.2. **Interpretation of results**

A set of test pieces shall be considered acceptable if all tests give a satisfactory result.

ANNEX 14

FLEXIBLE PLASTIC GLAZINGS OTHER THAN WINDSCREENS

1. DEFINITION OF TYPE

Flexible plastic glazings shall be considered to belong to different types if they differ in at least one of the following principal or secondary characteristics.

1.1. The principal characteristics are as follows:

- 1.1.1. The manufacturer's trade name or marks,
- 1.1.2. The chemical designation of the material.
- 1.1.3. The classification of the material by the manufacturer.
- 1.1.4. The process of manufacture.
- 1.1.5. The nominal thickness (e), a manufacturing tolerance being allowed: $\pm (0.1 \text{ mm} + 0.1 (e))$; $d > 0.1 \text{ mm}$.
- 1.1.6. The colouring of the plastic product.
- 1.1.7. The nature of the surface coating(s).

1.2. The secondary characteristics are as follows:

- 1.2.1. no secondary characteristic is involved.

2. GENERAL

- 2.1. In the case of flexible plastic glazings the tests shall be conducted on flat test pieces which either are cut from finished products or are specially produced for that purpose. In both cases the test piece must in every respect be rigorously representative for the panes which are produced in the run.
- 2.2. The test pieces must be freed from protecting masks and have to be cleaned carefully before the test.
 - 2.2.1. They must be stored for 48 hours at a temperature of $23^{\circ}\text{C} \pm 2^{\circ}\text{C}$ and a relative humidity of $50\% \pm 5\%$.

3. FLEXIBILITY TEST AND FOLD TEST

3.1. Indices of difficulty of the secondary characteristics

No secondary characteristic is involved.

3.2. Number of test pieces

One flat test piece measuring 300 mm x 25 mm shall be subjected to testing.

3.3. Test method

- 3.3.1. The method used shall be that described in Annex 3 Paragraph 12.

3.4. Interpretation of results

For a test piece or sample to be considered flexible its vertical deflection shall be more than 50 mm after 60 seconds.

10 seconds after a 180°-folding, the material must not show any fracture or damage at the point of bending.

4. **MECHANICAL STRENGTH TESTS**

4.1. **Indices of difficulty of the secondary characteristics**

No secondary characteristic is involved.

4.2. **227 g ball test at 20° C ± 5° C**

4.2.1. **Number of test pieces**

Ten flat square pieces 300 + 10/ - 0 mm shall be subjected to testing.

4.2.2. **Test method**

4.2.2.1. The method used shall be that prescribed in Annex 3, Paragraph 2.1.

4.2.2.2. The height of drop is 2 m for all thicknesses.

4.2.3. **Interpretation of results**

4.2.3.1. The ball test shall be considered to have given a satisfactory result if the ball does not penetrate the test piece.

4.2.3.2. A set of test pieces shall be considered acceptable if at least eight of the ten tests give a satisfactory result.

4.3. **227 g ball test at -20° C ± -2° C**

4.3.1. To minimize the temperature change of the test piece the test shall be performed within 30 seconds of the removal of the test piece from the conditioning appliance.

4.3.2. The test method shall be that described in Paragraph 4.2.2. of this annex, except that the test piece temperature is -20°C ± -2°C.

4.3.3. Interpretation of results as in Paragraph 4.2.3. of this annex.

5. **TEST OF RESISTANCE TO THE ENVIRONMENT**

5.1. **Test of resistance to simulated weathering**

5.1.1. *Indices of difficulty and test method*

The requirements of Annex 3, Paragraph 6.4 shall apply. The total ultraviolet radiant exposure with the long arc Xenon lamp shall be 500 MJ/m². During irradiation the test pieces shall be exposed to water spray in continuous cycles. During a cycle of 120 minutes the test pieces are exposed to light without water spray for 102 minutes, and to light with water spray for 18 minutes.

5.1.1.1. Other methods giving equivalent results shall be allowed.

5.1.2. *Number of test pieces*

Three flat test pieces 130 x 40 mm cut from a flat sheet sample shall be subjected to testing.

5.1.3. *Interpretation of results*

The resistance to the simulated weathering test shall be considered to have given a satisfactory result if:

5.1.3.1. The light transmittance measured in accordance with Annex 3, Paragraph 9.1 does not fall below 95% of the pre-weathering value. Additionally, for windows which are required for driver visibility the value shall not fall below 70%.

5.1.3.2. No bubbles or other visible decompositions, discolourations, milkiness or crazing shall occur during weathering.

5.1.4. A set of test pieces shall be considered acceptable if all the tests give a satisfactory result.

6. **OPTICAL QUALITIES**

The requirements of Annex 3, Paragraph 9.1 shall apply for products which are requisite for driver visibility.

6.1. *Interpretation of results*

A set of samples shall be considered acceptable if all the tests give a satisfactory result.

7. **FIRE RESISTANCE TEST**

7.1. **Indices of difficulty and test method**

The requirements of Annex 3, Paragraph 10 shall apply.

7.2. **Interpretation of results**

The fire-resistance test shall be considered to have given a satisfactory result if the burning rate is less than 90 mm/min.

7.2.1. A set of test pieces shall be considered acceptable if at least four of the five tests give a satisfactory result.

8. **RESISTANCE TO CHEMICALS**

8.1. **Indices of difficulty and test method**

The requirements of Annex 3, Paragraph 11 shall apply.

8.2. **Interpretation of results**

A set of test pieces shall be considered acceptable if all the tests give a satisfactory result.

ANNEX 15

RIGID PLASTIC DOUBLE GLAZED UNITS

1. DEFINITION OF TYPE

Double glazed units shall be considered to belong to different types if they differ in at least one of the following principal or secondary characteristics.

1.1. The principal characteristics are as follows:

- 1.1.1. The manufacturer's trade name or marks,
- 1.1.2. The chemical designation of the component sheets.
- 1.1.3. The classification of the sheets by the manufacturer.
- 1.1.4. The thickness of the component sheets.
- 1.1.5. The process of window manufacture.
- 1.1.6. The width of air gap between the component plastic sheets.
- 1.1.7. The colouring of the plastic sheets.
- 1.1.8. The nature and type of coating.

1.2. The secondary characteristics are as follows:

- 1.2.1. No secondary characteristic is involved.

2 GENERAL

- 2.1. In the case of rigid plastic double glazed units, tests will be performed on either flat test pieces or finished parts depending upon test requirements.
- 2.2. The test pieces must be freed from protecting maskings and cleaned before testing. They must be stored for 24 hours at a temperature of $23^{\circ}\text{C} \pm 2^{\circ}\text{C}$ and a relative humidity of $50\% \pm 5\%$ prior to testing.
- 2.3. The nominal thickness tolerance for extruded plastic products is $\pm 10\%$ of the nominal thickness. For plastic products produced by other techniques (e.g. cast acrylic sheet), the acceptable thickness tolerance is given by the equation (thickness tolerance limits (mm)) = $\pm (0.4 + 0.1 e)$ (mm) where e is the sheet nominal thickness.

Reference standard is ISO 7823/1

NB: Where the thickness is not constant due to forming techniques, the measurement of the thickness will be at the geometric centre of the unit.

- 2.4. Test carried out on rigid plastic double glazed units having a nominal width of gap e measured at the geometrical centre shall be considered to be applicable to all rigid plastic double glazed units having the same characteristics and a nominal width of gap $e \pm 5$ mm.

3. **FLEXIBILITY TEST**

3.1. **Indices of difficulty of the secondary characteristics**

No secondary characteristic is involved.

3.2. **Number of test pieces**

One test piece for each component sheet of the window measuring 300 mm x 25 mm shall be subjected to testing.

3.3. **Test method**

3.3.1. The method used shall be that described in Annex 3 Paragraph 12.

3.4. **Interpretation of results**

The vertical deviation of both component sheets shall be less than 50 mm after 60 seconds.

4. **HEADFORM TEST**

4.1. **Indices of difficulty of the secondary characteristics**

No secondary characteristic is involved.

4.2. **Number of samples**

Six representative windows of size 1170 x 570 mm (+ 0/- 2 mm in both directions) shall be subjected to testing. The samples will have provision for peripheral clamping.

4.3. **Test method**

4.3.1. The test method used shall be that described in Annex 3, Paragraph 3.2. impact will be on the inner side of the window.

4.3.2. For panes like partitions, separating and side windows (classification VIII/A) the drop height shall be 3 m. The HIC value is also to be measured.

4.3.3. For panes which do not have contact possibilities as well as for small windows in vehicles and for all windows in trailers (classification VIII/B) there will be no headform testing. A small window is a window into which a 150 mm diameter circle cannot be scribed.

4.4. **Interpretation of results**

The test shall be deemed to have given a satisfactory result if the following conditions are fulfilled:

4.4.1. The test sample is not penetrated nor shall it break into fully separate large pieces.

4.4.2. The HIC value is less than 1000.

4.4.3. A set of samples shall be considered acceptable if all the tests give a satisfactory result.

5. **MECHANICAL STRENGTH TEST 227 g BALL TEST**

5.1. **Indices of difficulty of the secondary characteristics:**

No secondary characteristic is involved.

5.2. **Number of test pieces**

Ten flat test pieces of the outer component sheet or ten finished parts of size 300 x 300 mm + 10/ - 0 mm shall be subjected to testing.

5.3. **Test method**

5.3.1. The method used shall be that prescribed in Annex 3, Paragraph 2.1.

Impact will be on the outer side of the test window

5.3.2. The height of drop for the various thickness values of the outer component of the window is given in the table below:

outer sheet thickness (mm)	height of drop (m)
< 3	2
4	3
5	4
> 6	5

For intermediate values of thickness in the interval between 3 mm and 6 mm the height of drop must be interpolated.

5.4. **Interpretation of results**

5.4.1. The ball test shall be considered to have given a satisfactory result if the following conditions are met:

- the ball does not penetrate the test piece
- the test piece does not break into separate pieces.

5.4.2. A set of test pieces shall be considered acceptable if at least eight of the ten tests give a satisfactory result.

5.5. **227 g ball test at -20°C +/- 2°C**

5.5.1. To minimise the temperature change of the test piece, the test shall be performed within 30 seconds of the removal of the test piece from the conditioning appliance.

5.5.2. The test method shall be that described in Paragraph 5.3 of this annex, except that the test temperature is -20°C +/- 2°C.

5.5.3. Interpretation of results as in Paragraph 5.4 of this annex.

6. **TEST RESISTANCE TO THE ENVIRONMENT**

6.1. **Test of resistance to abrasion**

6.1.1. *Indices of difficulty and test method*

The requirements of Annex 3, Paragraph 4 shall apply; the test is performed for either 1000, 500 or 100 cycles to measure abrasion of the surface of the product.

6.1.2. Three flat square test pieces of 100 mm for each type of surface shall be subjected to testing.

6.1.3. *Interpretation of results*

6.1.3.1. For safety glazings used at places which are requisite for the driver visibility, the abrasion test shall be considered to have given a satisfactory result if the total light scatter after abrasion does not exceed 2% after 1000 cycles on the outer side of the test window and 4% after 100 cycles on the inner side of the test window.

6.1.3.2. For safety glazings used at places which are not requisite for the driver visibility, the abrasion test shall be considered to have given a satisfactory result if the total light scatter after abrasion does not exceed 10% after 500 cycles on the outer side of the test window and 4% after 100 cycles on the inner side of the test window.

6.1.3.3. No abrasion testing is requisite for rigid plastic double glazings for trailers and for motor caravans with a gross vehicle mass greater than 2 500 kgs.

6.1.4. A set of test pieces shall be considered acceptable if all the tests give a satisfactory result.

6.2. **Test of resistance to simulated weathering**

6.2.1. *Indices of difficulty and test method*

The requirements of Annex 3, Paragraph 6.4 shall apply. The total ultraviolet radiant exposure with the long arc

Xenon lamp shall be 500 MJ/m². During irradiation the test pieces shall be exposed to water spray in continuous cycles. During a cycle of 120 minutes the test pieces are exposed to light without water spray for 102 minutes, and to light with water spray for 18 minutes.

6.2.1.1. Other methods giving equivalent results shall be allowed.

6.2.2. *Number of test pieces*

Three flat test pieces 130 x 40 mm cut from the outer skin of the window shall be subjected to testing.

6.2.3. *Interpretation of results*

6.2.3.1. The resistance to the simulated weathering shall be considered to have given a satisfactory result if:

6.2.3.1.1. The light transmittance measured in accordance with Annex 3, Paragraph 9.1 does not fall below 95% of the pre-weathering value. Additionally, for windows which are required for driver visibility the value shall not fall below 70%.

6.2.3.1.2. No bubbles or other visible decompositions, discolourations, milkiess or crazing shall occur during weathering.

6.2.4. A set of test pieces shall be considered acceptable if all the tests give a satisfactory result.

6.3. **Cross-cut test**

Indices of difficulty and test method

The requirements of Annex 3, Paragraph 13 shall apply only to coated products.

6.3.2. The cross-cut test shall be carried out on one of the test pieces from 6.2.

6.3.3. *Interpretation of results*

6.3.3.1. The cross-cut test shall be considered to have given a satisfactory result if the cross-cut value Gt 1 is met.

6.4. **Resistance-to-humidity test**

6.4.1. *Indices of difficulty and test method*

The requirements of Annex 3, Paragraph 7 shall apply.

6.4.2. Ten square pieces or test windows of 300 x 300 mm shall be subjected to testing.

6.4.3. *Interpretation of results*

6.4.3.1. The humidity test shall be considered to have given a satisfactory result if:

6.4.3.1.1. No visible decompositions like bubbles or milkiness occur on any sample,

6.4.3.1.2. and if the light transmittance measured according to Annex 3, Paragraph 9.1 does not fall to less than 95% of the pre-test value and additionally to no less than 70% for any window required for driver visibility.

6.4.4. After testing the test pieces shall be stored for at least 48 hours at a temperature of $23^{\circ}\text{C} \pm 2^{\circ}\text{C}$ and a relative humidity of $50\% \pm 5\%$, and then subjected to the 227 g ball drop test described under item 5 of this annex.

7. **OPTICAL QUALITIES**

The requirements of Annex 3, Paragraph 9.1 shall apply for products which are requisite for driver visibility.

7.1. *Interpretation of results*

A set of samples shall be considered acceptable if all the tests give a satisfactory result.

8. **FIRE RESISTANCE TEST**

8.1. **Indices of difficulty and test method**

The requirements of Annex 3, Paragraph 10 shall apply.

8.2. **Interpretation of results**

The test needs to be performed separately on both surfaces of the double glazed unit.

The fire-resistance test shall be considered to have given a satisfactory result if the burning rate is less than 90 mm/min.

8.2.1. A set of test pieces shall be considered acceptable if at least four of the five tests give a satisfactory result.

9. **RESISTANCE TO CHEMICALS**

9.1. **Indices of difficulty and test method**

The requirements of Annex 3, Paragraph 11 shall apply.

Testing will only be applied to samples representative of the outer face of the double glazed unit.

9.2. **Interpretation of results**

A set of test pieces shall be considered acceptable if all the tests give a satisfactory result.

ANNEX 16

MEASUREMENT OF THE HEIGHT OF SEGMENT AND POSITION OF THE POINTS OF IMPACT

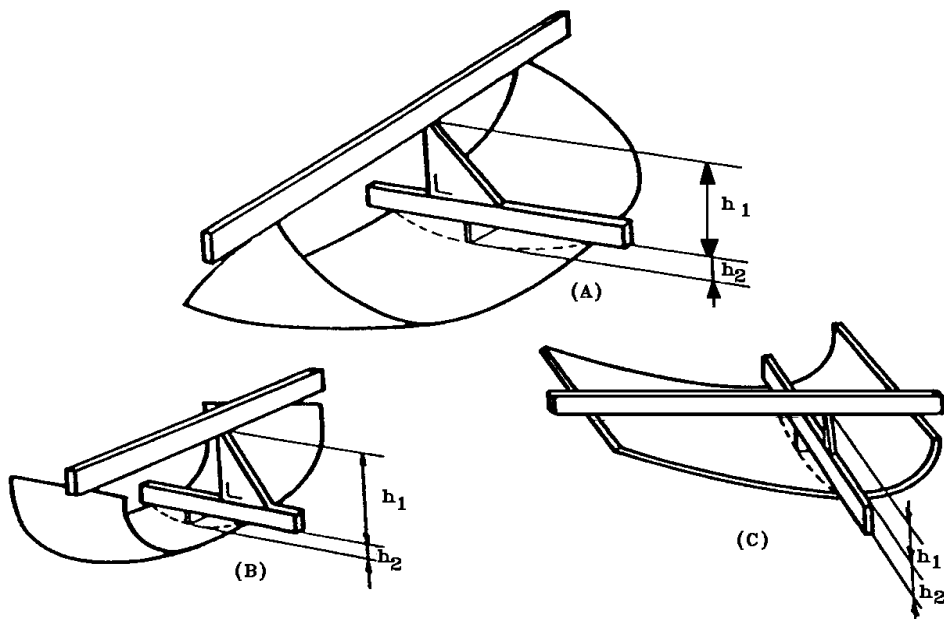

Figure 1

Determination of the height of segment 'h'

In the case of a safety-glazing pane having a simple curvature, the height of segment will be equal to: h_1 maximum.

In the case of a safety-glazing pane having a double curvature, the height of segment will be equal to: h_1 maximum + h_2 maximum.

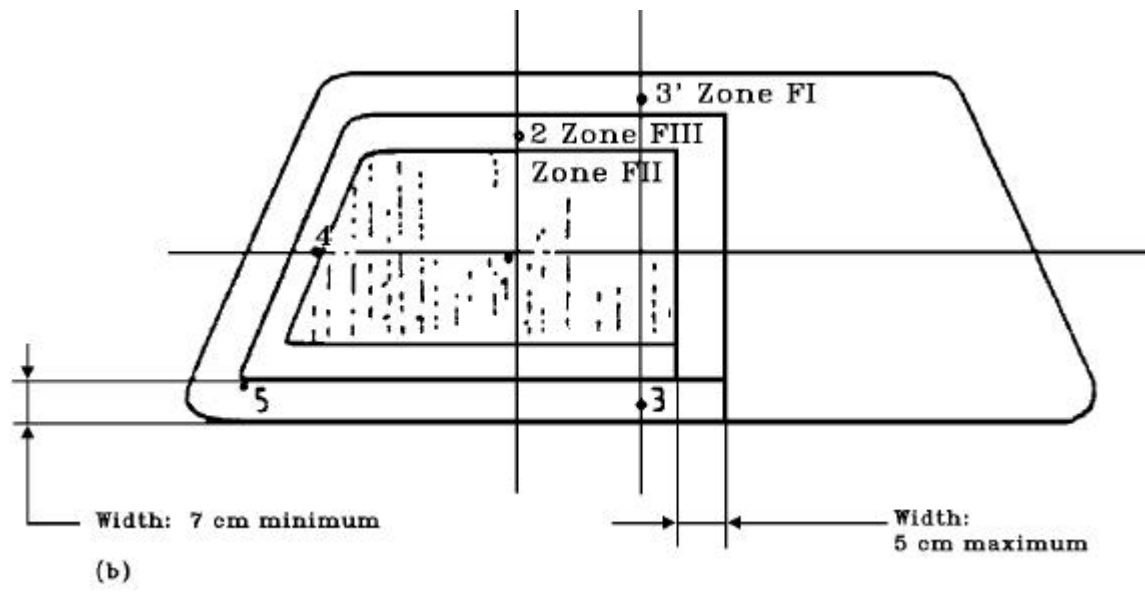
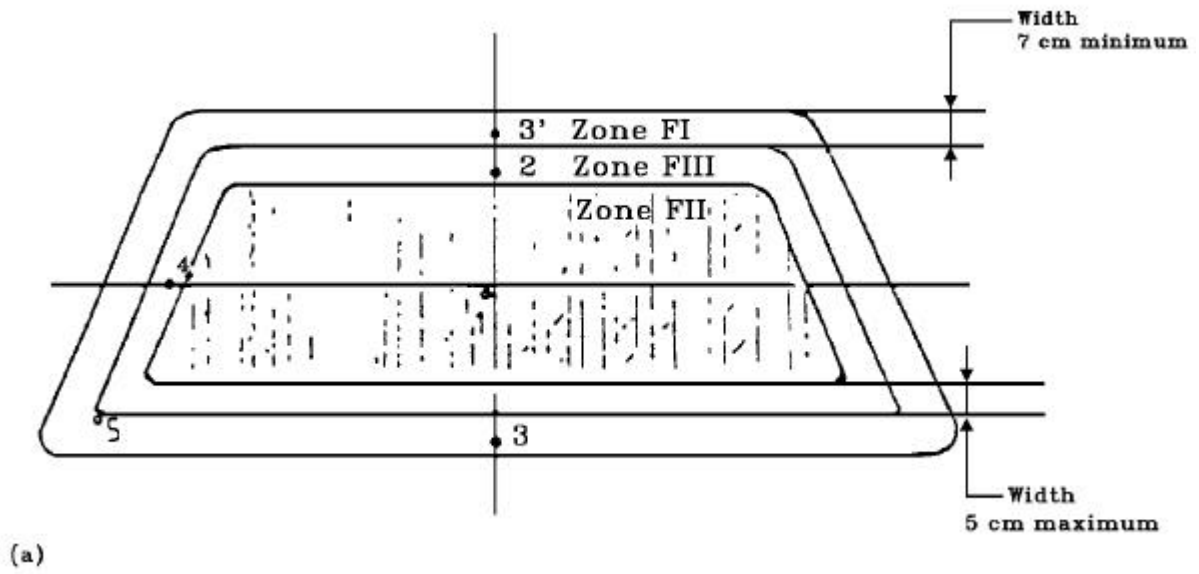
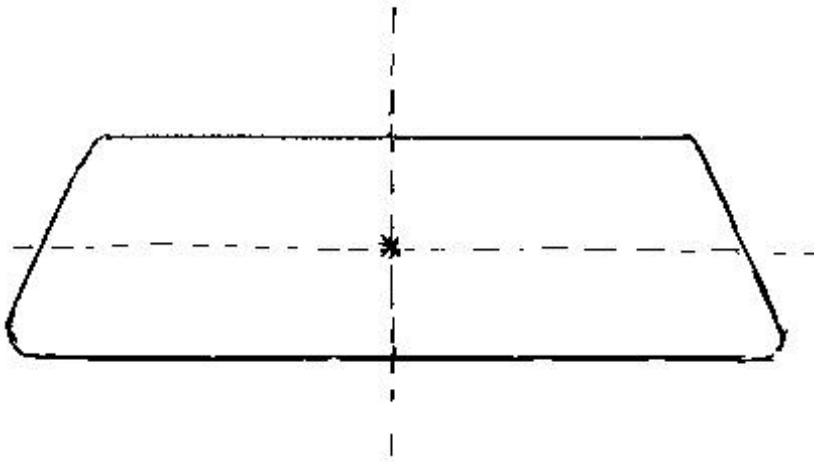
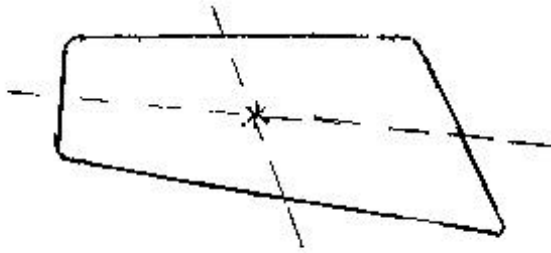
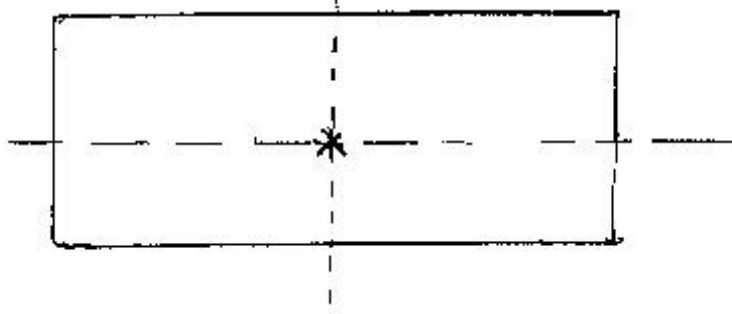

Figure 2
 Prescribed points of impact for windscreens



Breakage Point for Uniformly toughened Glass Panes

ANNEX 17

PROCEDURES FOR DETERMINING TEST AREAS ON WINDSCREENS OF [M₁ CATEGORY VEHICLES] IN RELATION TO THE POINTS 'V'

1. POSITION OF THE 'V' POINTS

1.1. The position of the 'V' points in relation to the 'R' point (see Annex 16 to this Regulation), as indicated by the X Y and Z co-ordinates in the three-dimensional reference system, are shown in tables 1 and 2.

1.2. Table 1 gives the basic co-ordinates for a design seat-back angle of 25°. The positive direction of the co-ordinates is shown in this Annex, Figure 3.

Table 1

'V' Point	X	Y	Z
V ₁	68 mm	- 5 mm	665 mm
V ₂	68 mm	- 5 mm	589 mm

1.3. Correction for design seat-back angles other than 25°.

1.3.1. Table 2 shows the further corrections to be made to the X and Z co-ordinates of each 'V' point when the design seat-back angle is not 25°. The positive direction of the co-ordinates is shown in this Annex, Figure 3.

2. TEST AREAS

2.1. Two test areas shall be determined from the 'V' points

2.2. Test area A is the area on the apparent outer surface of the windscreen bounded by the following four planes extending forward from the 'V' points (see Figure 1):

a vertical plane passing through V₁ and V₂ and inclined at 13° to the left of the axis in the case of left-hand drive vehicles and to the right of the X axis in the case of right-hand drive vehicles;

a plane parallel to the Y axis passing through V₁ and inclined upwards at 3° from the X axis;

a plane parallel to the Y axis passing through V₂ and inclined downwards at 1° from the X axis;

a vertical plane passing through V₁ and V₂ and inclined at 20° to the right of the X axis in the case of left-hand drive vehicles and to the left of the X axis in the case of right-hand drive vehicles.

Table 2

Seat back angle (degrees)	Horizontal coordinates X	Vertical coordinates Z	Seat back angle (degrees)	Horizontal co-ordinates X	Vertical co-ordinates Z
5	-186 mm	28 mm	23	-17 mm	5 mm
6	-176 mm	27 mm	24	-9 mm	2 mm
7	-167 mm	27 mm	25	0 mm	0 mm
8	-157 mm	26 mm	26	9 mm	-3 mm
9	-147 mm	26 mm	27	17 mm	-5 mm
10	-137 mm	25 mm	28	26 mm	-8 mm
11	-128 mm	24 mm	29	34 mm	-11 mm
12	-118 mm	23 mm	30	43 mm	-14 mm
13	-109 mm	22 mm	31	51 mm	-17 mm
14	-99 mm	21 mm	32	59 mm	-21 mm
15	-90 mm	20 mm	33	67 mm	-24 mm
16	-81 mm	18 mm	34	76 mm	-28 mm
17	-71 mm	17 mm	35	84 mm	-31 mm
18	-62 mm	15 mm	36	92 mm	-35 mm
19	-53 mm	13 mm	37	100 mm	-39 mm
20	-44 mm	11 mm	38	107 mm	-43 mm
21	-35 mm	9 mm	39	115 mm	-47 mm
22	-26 mm	7 mm	40	123 mm	-52 mm

2.3. Test area B is the area of the outer surface of the windscreen which is more than 25 mm from the outer edge of the transparent area and is bounded by the intersection of the following four planes with the outer surface of the windscreen (see Figure 2):

a plane inclined upward from the X axis at 7°, passing through V₁ and parallel to the Y axis;

a plane inclined downward from the X axis at 5°, passing through V₂ and parallel to the Y axis;

a vertical plane passing through V₁ and V₂ and forming an angle of 17° to the left of the X axis in the case of left-hand drive vehicles and to the right of the X axis in the case of right-hand drive vehicles;

a plane symmetrical with respect to the former plane in relation to the longitudinal median plane of the vehicle.

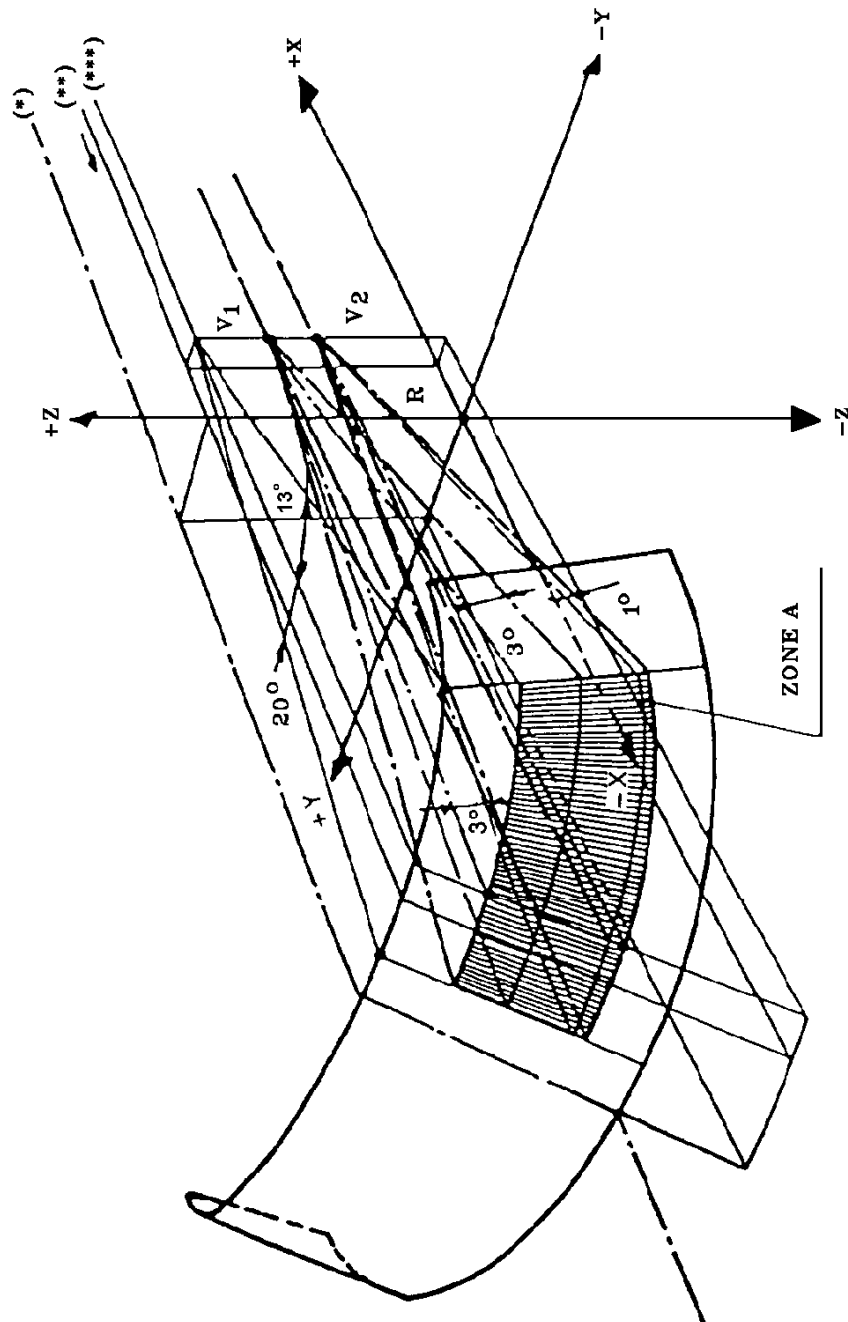

- (*) Trace of longitudinal plane of symmetry of the vehicle
- (**) Trace of vertical plane passing through 'R'
- (***) Trace of vertical plane passing through V₁ and V₂

Figure 1
Test Area 'A' (example of a left-hand drive vehicle)

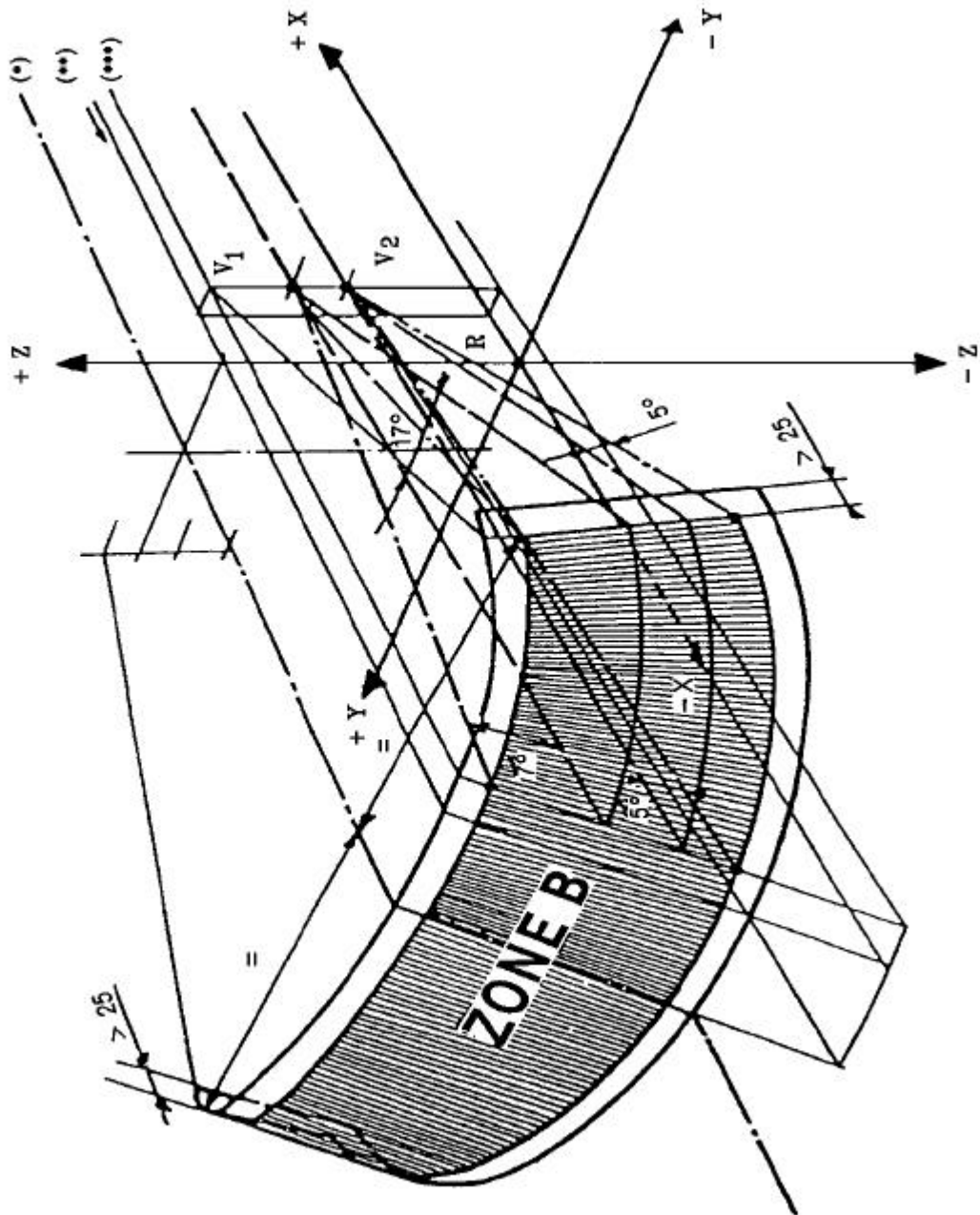

- (*) Trace of longitudinal plane of symmetry of the vehicle
- (**) Trace of vertical plane passing through 'R'
- (***) Trace of vertical plane passing through V₁ and V₂

Figure 2
Test Area 'B' (example of a left-hand drive vehicle)

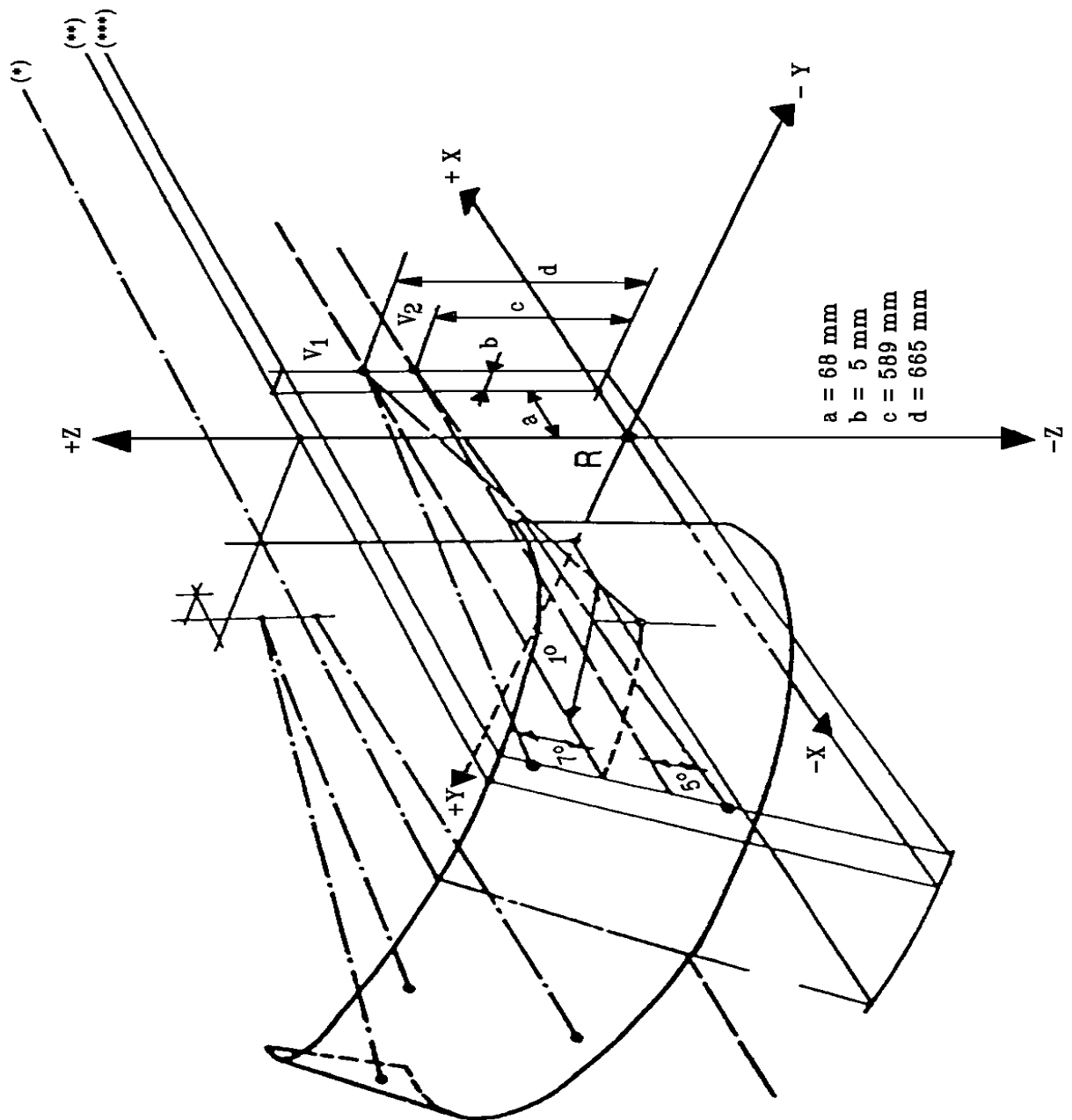

- (*) Trace of longitudinal plane of symmetry of the vehicle
- (**) Trace of vertical plane passing through 'R'
- (***) Trace of vertical plane passing through V_1 and V_2

Figure 3
Determination of V Points for a Seat-Back Angle of 25°
(example of a left-hand drive vehicle)

ANNEX 18

PROCEDURE FOR DETERMINING THE 'H' POINT AND THE ACTUAL TORSO ANGLE FOR SEATING POSITIONS IN MOTOR VEHICLES

1. PURPOSE

The procedure described in this Annex is used to establish the point location and the actual torso angle for one or several seating positions in a motor vehicle and to verify the relationship of measured data to design specification given by the vehicle manufacturer. ⁽¹⁾

2. DEFINITIONS

For the purposes of this Annex.

- 2.1. **"Reference data"** means one or several of the following characteristics of a seating position:
 - 2.1.1. the 'H' point and the 'R' point and their relationship;
 - 2.1.2. the actual torso angle and the design torso angle and their relationship.
- 2.2. **"Three-dimensional H-point machine"** (3 DH machine) means the device used for the determination of H point and actual torso angles. This device is described in Appendix 1 to this Annex.
- 2.3. **"H point"** means the pivot centre of the torso and thigh of the 3 DH machine installed in the vehicle seat in accordance with the procedure described in Paragraph 3 below. The H point is located in the centre of the centre line of the device which is between the H point sight buttons on either side of the 3 DH machine. The H point corresponds theoretically to the R point (for tolerances, see Paragraph 3.2.2. below). Once determined in accordance with the procedure described in Paragraph 4, the H point is considered as fixed in relation to the semi-cushion structure and as moving with it when the seat is adjusted.
- 2.4. **"R point"** or **"seating reference point"** means a design point defined by the vehicle manufacturer for each seating position and established with respect to the three-dimensional reference system.
- 2.5. **"Torso line"** means the centre line of the probe of the 3 DH machine with the probe in the fully rearward position.
- 2.6. **"Actual torso angle"** means the angle measured between a vertical line through the H point and the torso line using the back angle quadrant on the 3 DH machine. The actual torso angle corresponds theoretically to the design torso angle (for tolerances, see Paragraph 3.2.2. below).
- 2.7. **"Design torso angle"** means the angle measured between a vertical line through the R point and the torso line in a position corresponding to the design position of the seat-back specified by the vehicle manufacturer.
- 2.8. **"Centre plane of occupant"** (CPO) means the median plane of the 3 DH machine positioned in each designed seating position; it is represented by the co-ordinate of the H point on the Y axis. For individual seats, the centre plane of the seat coincides with the centre plane of the occupant. For other seats, the centre plane of the occupant is specified by the manufacturer.

⁽¹⁾ In any seating position other than front seats where the H point cannot be determined using the three-dimensional machine or other procedures, the R point indicated by the vehicle manufacturer may be taken as a reference at the discretion of the competent authority.

- 2.9. "Three-dimensional reference system" means a system as described in Appendix 2 to this Annex.
- 2.10. "Fiducial marks" are physical points (holes, surfaces, marks or indentations) on the vehicle body as defined by the manufacturer.
- 2.11. "Vehicle measuring attitude" means the position of the vehicle as defined by the co-ordinates of fiducial marks in the three-dimensional reference system.

3. REQUIREMENTS

3.1. Data presentation

For each seating position where reference data are required in order to demonstrate compliance with the provisions of this Regulation, all or an appropriate selection of the following data shall be presented in the form indicated in Appendix 3 to this Annex:

- 3.1.1. The co-ordinates of the R point relative to the three-dimensional reference system,
- 3.1.2. The design torso angle,
- 3.1.3. All indications necessary to adjust the seat (if it is adjustable) to the measuring position set out in Paragraph 4.3. below.

3.2. Relationship between measured data and design specifications

- 3.2.1. The co-ordinates of the H point and the value of the actual torso angle obtained by the procedure set out in Paragraph 4 below shall be compared, respectively, with the co-ordinates of the R point and the value of the design torso angle indicated by the vehicle manufacturer.
- 3.2.2. The relative positions of the R point and the H point and the relationship between the design torso angle and the actual torso angle shall be considered satisfactory for the seating position in question if the H point, as defined by its co-ordinates, lies within a square of 50 mm side with horizontal and vertical sides whose diagonals intersect at the R point, and if the actual torso angle is within 5° of the design torso angle.
- 3.2.3. If these conditions are met, the R point and the design torso angle shall be used to demonstrate compliance with the provisions of this Regulation.
- 3.2.4. If the H point or the actual torso angle does not satisfy the requirements of Paragraph 3.2.2. above, the H point and the actual torso angle shall be determined twice more (three times in all). If the results of two of these three operations satisfy the requirements, the conditions of Paragraph 3.2.3. above shall apply.
- 3.2.5. If the results of at least two of the three operations described in Paragraph 3.2.4. above do not satisfy the requirements of Paragraph 3.2.2. above, or if the verification cannot take place because the vehicle manufacturer has failed to supply information regarding the position of the R point or regarding the design torso angle, the centroid of the three measured points or the average of the three measured angles shall be used and be regarded as applicable in all cases where the R point or the design torso angle is referred to in this Regulation.

4. PROCEDURE FOR DETERMINING THE H POINT AND THE ACTUAL TORSO ANGLE

- 4.1. The vehicle shall be preconditioned at a temperature of $20^{\circ}\text{C} \pm 10^{\circ}\text{C}$, at the manufacturer's discretion, to ensure that the seat material reaches room temperature. If the seat to be checked has never been used, a 70 to 80 kg person or device shall be placed on the seat twice for one minute to flex the cushion and back. At the manufacturer's request, all seat assemblies shall remain unloaded for a minimum period of 30 minutes prior to installation of the 3 DH machine.
- 4.2. The vehicle shall be in the measuring attitude defined in Paragraph 2.11. above.
- 4.3. The seat, if adjustable, shall be adjusted first to the rearmost normal driving or riding position, as indicated by the vehicle manufacturer, taking into consideration only the longitudinal adjustment of the seat, excluding seat travel used for purposes other than normal driving or riding positions. Where other modes of seat adjustment exist (vertical, angular, seat-back, etc.) these will be then adjusted to the position specified by the vehicle manufacturer. For suspension seats, the vertical position shall be rigidly fixed corresponding to a normal driving position as specified by the manufacturer.
- 4.4. The area of the seating position taken up by the 3 DH machine shall be covered by a muslin cotton, of sufficient size and appropriate texture, described as a plain cotton fabric having 18.9 threads per cm^2 and weighing 0.228 kg/m^2 , or knitted or non-woven fabric having equivalent characteristics.

If the test is performed on a seat outside the vehicle, the floor on which the seat is placed shall have the same essential characteristics ⁽¹⁾ as the floor of the vehicle in which the seat is intended to be used.
- 4.5. Place the seat and back assembly of the 3 DH machine so that the centre plane of the occupant (CPO) coincides with the 3 DH machine. At the manufacturer's request, the 3 DH machine may be moved inboard with respect to the CPO if the 3 DH machine is located so far outboard that the seat edge will not permit levelling of the 3 DH machine.
- 4.6. Attach the foot and lower leg assemblies to the seat-pan assembly, either individually or by using the T-bar and lower leg assembly. The line through the H point sight buttons shall be parallel to the ground and perpendicular to the longitudinal centre plane of the seat.

⁽¹⁾ Tilt angle, height difference with a seat mounting, surface texture, etc.

- 4.7. **Adjust the feet and leg positions of the 3 DH machine as follows:**
- 4.7.1. Seats for driver and outside front passenger:
- 4.7.1.1. Both feet and leg assemblies shall be moved forward in such a way that the feet take up natural positions on the floor, between the operating pedals if necessary. Where possible the left foot shall be located at approximately the same distance to the left of the centre plane of the 3 DH machine as the right foot is to the right. The spirit level verifying the transverse orientation of the 3 DH machine is brought to the horizontal by readjustment of the seat pan if necessary, or by adjusting the leg and foot assemblies towards the rear. The line passing through the H point sight buttons shall be maintained perpendicular to the longitudinal centre plane of the seat.
- 4.7.1.2. If the left leg cannot be kept parallel to the right leg and the left foot cannot be supported by the structure, move the left foot until it is supported. The alignment of the sight buttons shall be maintained.
- 4.7.2. Outboard rear seats:
- For rear seats or auxiliary seats, the legs are located as specified by the manufacturer. If the feet then rest on parts of the floor which are at different level, the foot which first comes into contact with the front seat shall serve as a reference and the other foot shall be so arranged that the spirit level giving the transverse orientation of the seat of the device indicates the horizontal.
- 4.7.3. Other seats:
- The general procedure indicated in Paragraph 4.7.1. above shall be followed, except that the feet shall be placed as specified by the vehicle manufacturer.
- 4.8. Apply lower leg and thigh weights and level the 3 DH machine.
- 4.9. Tilt the back pan forward against the forward stop and draw the 3 DH machine away from the seat-back using the T-bar. Reposition the 3 DH machine on the seat by one of the following methods:
- 4.9.1. If the 3 DH machine tends to slide rearward, use the following procedure: allow the 3 DH machine to slide rearward until a forward horizontal restraining load on the T-bar is no longer required, i.e. until the seat pan contacts the seat-back. If necessary, re-position the lower leg.
- 4.9.2. If the 3 DH machine does not tend to slide rearward, use the following procedure : slide the 3 DH machine rearwards by applying a horizontal rearward load to the T-bar until the seat pan contacts the seat-back (see Figure 2 of Appendix 1 to this Annex).
- 4.10. Apply a 100 ± 10 N load to the back and pan assembly of the 3 DH machine at the intersection of the hip angle quadrant and the T-bar housing. The direction of load application shall be maintained along a line passing through the above intersection to a point just above the thigh bar housing (see Figure 2 of Appendix 1 to this Annex). Then carefully return the back pan to the seatback. Care must be exercised throughout the remainder of the procedure to prevent the 3 DH machine from sliding forward.
- 4.11. Install the right and left buttock weights and then, alternatively, the eight torso weights. Maintain the 3 DH machine level.

- 4.12. Tilt the back pan forward to release the tension on the back-seat. Rock the 3 DH machine from side to side through a 10° arc (5° to each side of the vertical centre plane) for three complete cycles to release any accumulated friction between the 3 DH machine and the seat.

During the rocking action, the T-bar of the 3 DH machine may tend to diverge from the specified horizontal and vertical alignment. The T-bar must therefore be restrained by applying an appropriate lateral load during the rocking motions. Care should be exercised in holding the T-bar and rocking the 3 DH machine to ensure that no inadvertent exterior loads are applied in a vertical or fore-and-aft direction.

The feet of the 3 DH machine are not to be restrained or held during this step. If the feet change position, they should then be allowed to remain in that attitude.

Carefully return the back pan to the seat-back and check the two spirit levels for zero position. If any movement of the feet has occurred during the rocking operation of the 3 DH machine, they must be repositioned as follows:

Alternately, lift each foot off the floor the minimum necessary amount until no additional foot movement is obtained. During this lifting, the feet are to be free to rotate; no forward or lateral loads are to be applied. When each foot is placed back in the down position, the heel is to be in contact with the structure designed for this.

Check the lateral spirit level for zero position; if necessary, apply a lateral load to the top of the back pan sufficient to level the 3 DH machine's seat pan on the seat.

- 4.13. Holding the T-bar to prevent the 3 DH machine from sliding forward on the seat cushion, proceed as follows:

- (a) return the back pan to the seat-back,
- (b) alternately apply and release a horizontal rearward load, not to exceed 25 N, to the back angle bar at a height approximately at the centre of the torso weights until the hip angle quadrant indicates that a stable position has been reached after load release. Care should be taken to ensure that no exterior downward or lateral loads are applied to the 3 DH machine. If another level adjustment of the 3 DH machine is necessary, rotate the back pan forward, re-level, and repeat the procedure from 4.12.

- 4.14. Take all measurements:

4.14.1. The co-ordinates of the H point are measured with respect to the three-dimensional reference system.

4.14.2. The actual torso angle is read at the back angle quadrant of the 3 DH machine with the probe in its fully rearward position.

4.15. If a repetition of the installation of the 3 DH machine is desired, the seat assembly shall remain unloaded for a minimum period of 30 minutes prior to the repetition. The 3 DH machine shall not be left loaded on the seat assembly longer than the time required to perform the test.

4.16. If the seats in the same row can be regarded as similar (bench seat, identical seats, etc.) only one H point and one actual torso angle shall be determined for each row of seats, the 3 DH machine described in Appendix 1 to this Annex being seated in a place regarded as representative for the row.

This place shall be:

4.16.1. In the case of the front row, the driver seat,

4.16.2. In the case of the rear row or rows, an outer seat.

ANNEX 18— APPENDIX 1

DESCRIPTION OF THE THREE-DIMENSIONAL H POINT MACHINE^(*)

(3 DH machine)

1. BACK AND SEAT PANS

The back and seat pans are constructed of reinforced plastics and metal; they simulate human torso and thighs and are mechanically hinged at the H point. A quadrant is fastened to the probe hinged at the H point to measure the actual torso angle. An adjustable thick bar, attached to the seat pan, establishes the thigh centreline and serves as a baseline for the hip angle quadrant.

2. BODY AND LEG ELEMENTS

Lower leg segments are connected to the seat pan assembly at the T-bar joining the knees, which is a lateral extension of the adjustable thigh bar. Quadrants are incorporated in the lower leg segments to measure knee angles. Shoe and foot assemblies are calibrated to measure the foot angle. Two spirit levels orient the device in space. Body element weights are placed at the corresponding-centres of gravity to provide seat penetration equivalent to a 76 kg male. All joints of the 3 DH machine should be checked for free movement without encountering any noticeable friction.

^(*) For details of the construction of the 3 DH machines refer to Society of Automotive Engineers (SAE), 400 Commonwealth Drive, Warrendale, Pennsylvania 15096, United States of America.

The machine corresponds to that described in ISO Standard 6549-1980.

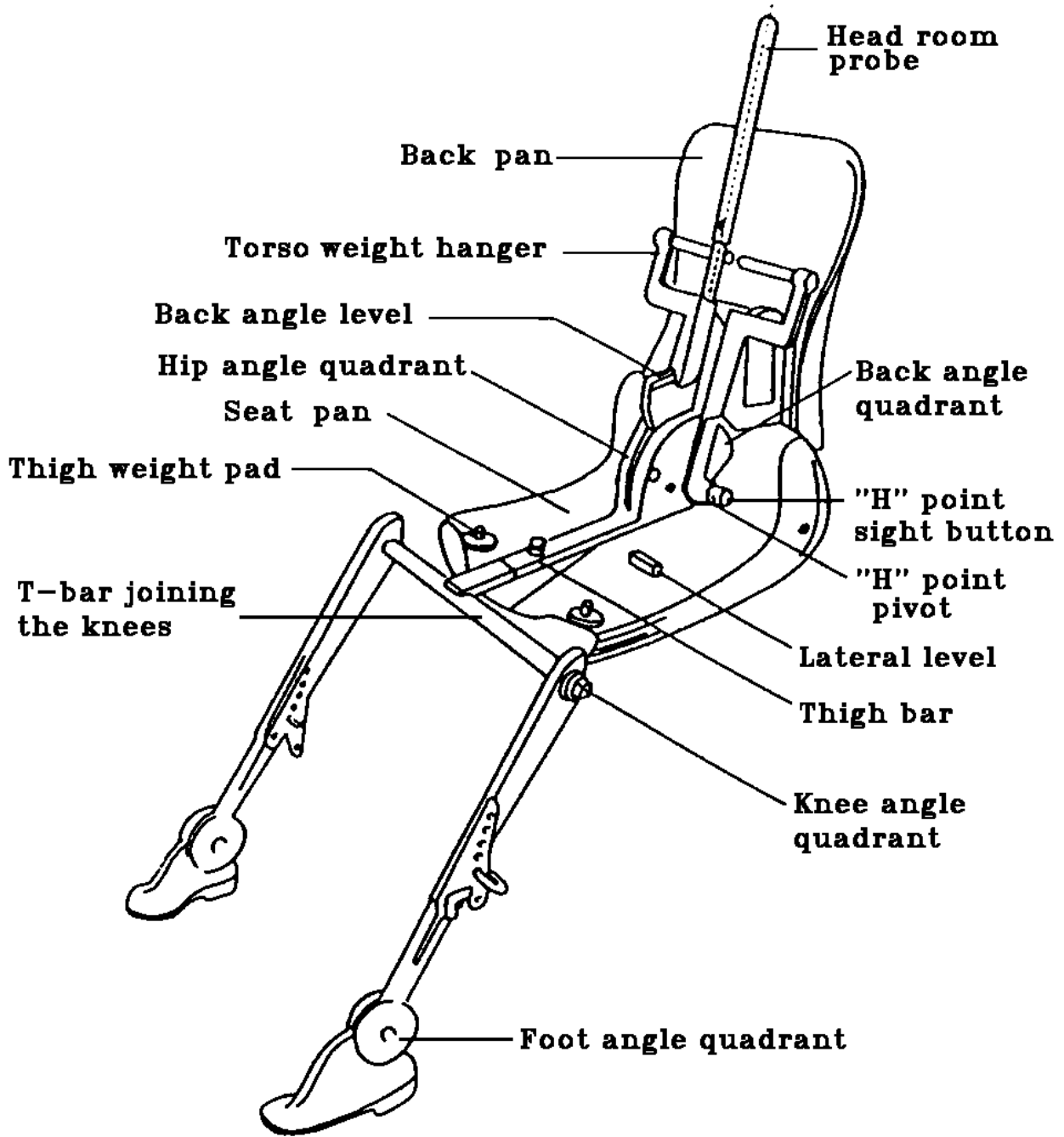

Figure 1
Designation of 3 DH machine components

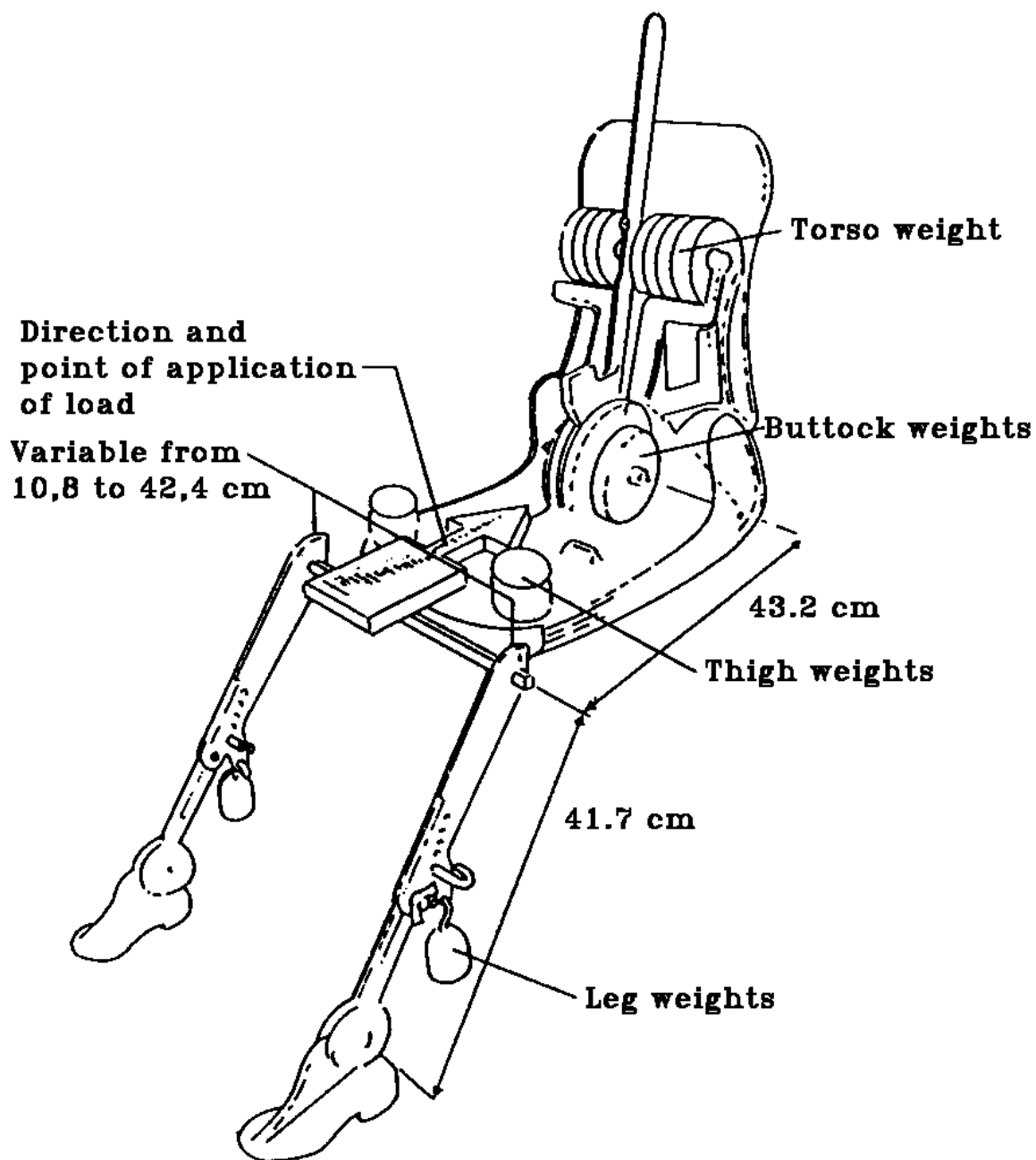
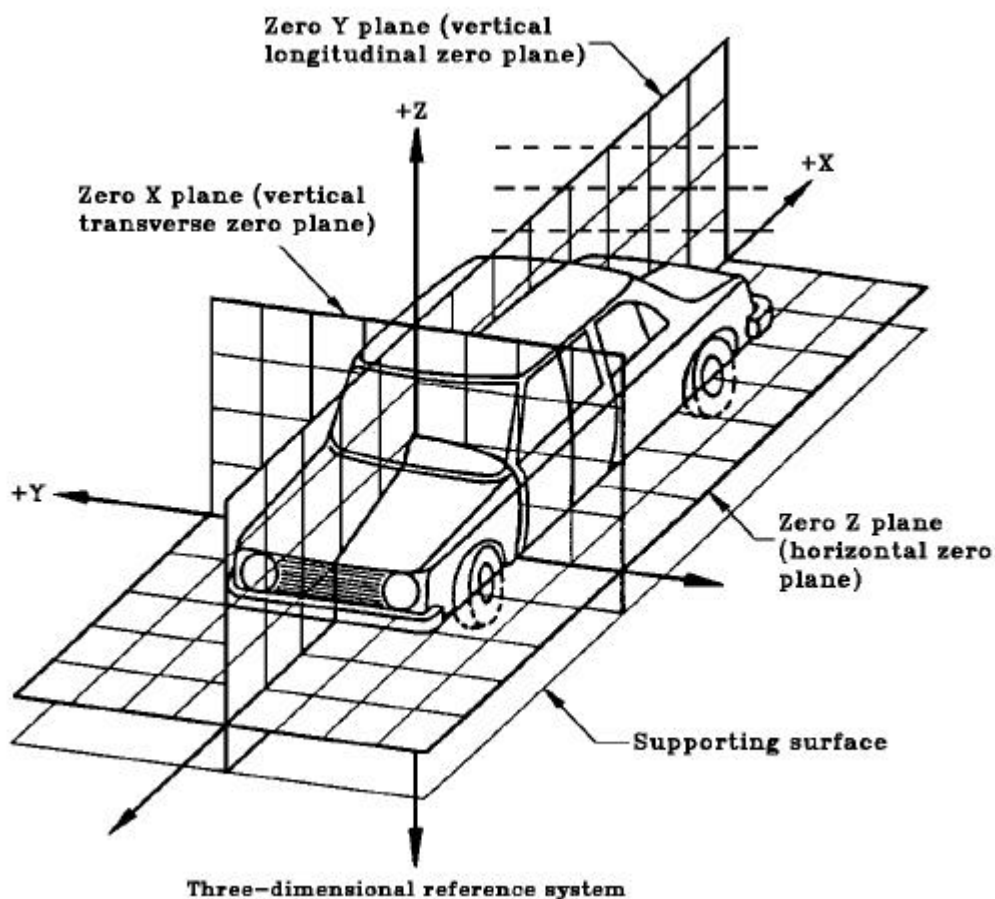

Figure 2
Dimensions of 3 DH machine components
and load distribution

ANNEX 18 — APPENDIX 2

THREE-DIMENSIONAL REFERENCE SYSTEM

1. The three-dimensional reference system is defined by three orthogonal planes established by the vehicle manufacturer (see Figure).^(*)
2. The vehicle measuring attitude is determined by positioning the vehicle on a supporting surface such that the co-ordinates of the fiducial marks correspond to the values indicated by the manufacturer.
3. The co-ordinates of the R point and the H point are determined in relation to the fiducial marks defined by the vehicle manufacturer.



^(*) The reference system corresponds to ISO Standard 4130 - 1978.

ANNEX 18 — APPENDIX 3

REFERENCE DATA CONCERNING SEATING POSITIONS

1. CODING OF REFERENCE DATA

Reference data are listed consecutively for each seating position. Seating positions are identified by a two-character code. The first character is an Arabic numeral which designates the row of seats, counting from the front to the rear of the vehicle. The second is a capital letter which designates the location of the seating position in a row, as viewed in the direction of forward motion of the vehicle; the following letters shall be used:

- L = left,
- C = centre,
- R = right.

2. DESCRIPTION OF VEHICLE MEASURING ATTITUDE

2.1. Co-ordinates of fiducial marks

- X.....
- Y.....
- Z.....

3. LIST OF REFERENCE DATA

3.1. Seating position:.....

3.1.1. Co-ordinates of the R point:

- X.....
- Y.....
- Z.....

3.1.2. Design torso angle:

3.1.3. Specifications for seat adjustment^(*)

- horizontal:
- vertical:
- angular:.....
- torso angle:.....

NOTE: List reference data for further seating positions under 3.2., 3.3., etc.

(*) Strike out what does not apply.