

Certification Procedures
for the
BioRID II
Crash Test Dummy

November 2010

Table of Contents

Introduction.....	4
BioRID Jacket Certification Procedures.....	5
Required Instrumentation.....	5
Pretest Preparation.....	5
BioRID Jacket Certification Test Procedure.....	7
BioRID Jacket Performance Specifications.....	7
BioRID Head Impact Pad Certification.....	8
Required Instrumentation.....	8
Pretest Preparation.....	8
BioRID Head Impact Pad Certification Test Procedure.....	9
BioRID Head Impact Pad Performance Specifications.....	9
BioRID Sled and Track Certification without Headrest.....	10
Required Instrumentation.....	10
Pretest Preparation.....	10
BioRID Sled and Track Certification without Headrest Test Procedure.....	11
BioRID Sled and Track Certification without Headrest Performance Specifications.....	12
BioRID Dummy Certification without Headrest.....	13
Required Instrumentation.....	13
Pretest Preparation.....	13
BioRID Dummy Certification without Headrest Test Procedures.....	14
BioRID Dummy Certification without Headrest Performance Specifications.....	15
BioRID Sled and Track Certification with Headrest.....	17
Required Instrumentation.....	17
Pretest Preparation.....	17
BioRID Sled and Track Certification with Headrest Test Procedure.....	18
BioRID Sled and Track Certification with Headrest Performance Specifications.....	19
BioRID Dummy Certification with Headrest.....	20
Required Instrumentation.....	20
Pretest Preparation.....	20
BioRID Dummy Certification with Headrest Test Procedure.....	20
BioRID Dummy Certification with Headrest Performance Specifications.....	21

List of Figures

Figure 1 - Impact Probe Alignment	5
Figure 2 - Jacket Core Assembly	6
Figure 3 - BioRID Jacket Test Setup	6
Figure 4 - Head Impact Pad Mounted on Sled.....	8
Figure 5 - BioRID Sled and Track Certification.....	11
Figure 6 - X Accelerometer at T1	14
Figure 7 - Head Setup Angle	14
Figure 8 - BioRID Sled and Track Certificaion with Headrest Test Setup	18

List of Tables

No table of figures entries found.

Introduction

The BioRID Dummy Certification Procedures are to insure proper dummy performance. These procedures include tests to verify the certification system is working correctly prior to certification and actual Dummy Certification tests. There are multiple tests to verify system inputs and two tests to verify dummy performance.

These include:

BioRID Sled and Track System Certification without Headrest Test – This test gives confidence the energy transfer device (ETD), sled track, and the probe are going to provide consistent test inputs to the BioRID Dummy Certification without Headrest.

BioRID Jacket Certification Test – This test verifies the jacket material stiffness stays consistent through time.

BioRID Head Impact Pad Certification for Headrest Test – This test insures confidence the Head Impact Pad will have consistent input to the Dummy Certification with Headrest test.

BioRID Dummy Certification without Headrest Test – This test insures the dummy's neck will provide consistent test results. The test also provides evidence the damper, neck bumpers, muscle substitute springs and cable, are working correctly as a system.

BioRID Sled and Track System Certification with Headrest – The test gives confidence that the energy transfer device (ETD), sled track, and the probe are going to provide consistent test inputs to the BioRID Dummy Certification with Headrest Test.

BioRID Dummy Certification with Headrest – This test insures the dummy will perform correctly when the head impacts a headrest during a test pulse commonly seen in sled testing.

A typical full dummy certification would follow these certification steps:

- 1) Install Track System and perform BioRID Track System Certification without Headrest
- 2) Change probe and perform BioRID Jacket Certification
- 3) Perform BioRID Head Impact Pad Certification
- 4) Change probe and repeat BioRID Sled and Track System Certification without Headrest
- 5) Perform BioRID Dummy Certification without Headrest
- 6) Change probe and perform BioRID Sled and Track System with Headrest
- 7) Perform BioRID Dummy Certification with Headrest

BioRID Jacket Certification Procedures

Note: Jacket Certification insures consistent material stiffness amongst jackets

Required Instrumentation

- Impact Probe Accelerometer
- Sled Accelerometer
- Impact Probe
- BioRID Sled Track Assembly (without weight package)
- Velocity Measurement

Pretest Preparation

- Remove the BioRID jacket from the dummy.
- Suspend the Impact Probe (specified in the test procedure below) so the longitudinal centerline of the probe is parallel ± 0.5 degrees to the flight of the probe.
- With the impact probe free hanging, align the probe centerline to the alignment hole on the face of the impact sled as shown in Figure 1.

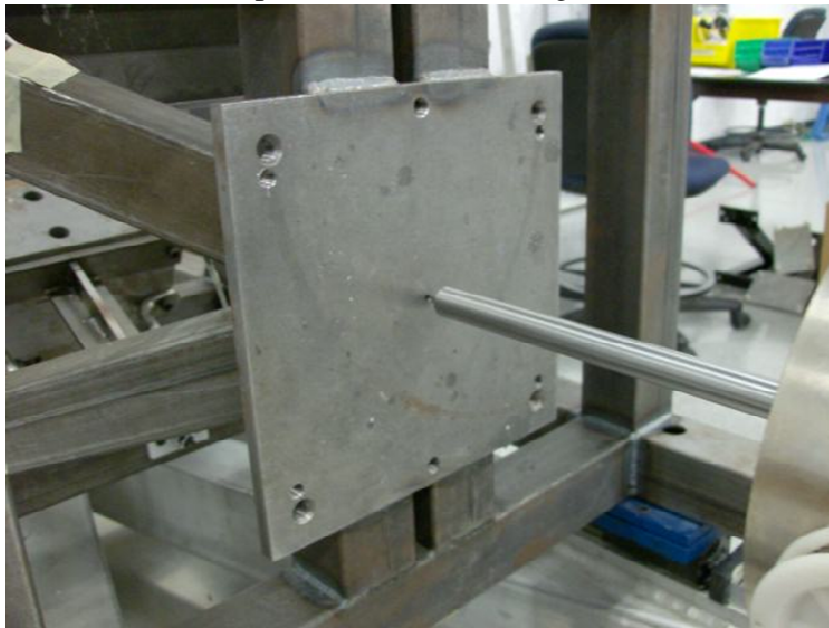

Figure 1 - Impact Probe Alignment

- Mount an accelerometer on the end of test probe opposite to the impact face with its sensitive axis in line with the longitudinal axis of the probe.
- Mount an accelerometer to the sled so its sensitive axis is parallel to the longitudinal centerline of the test probe.
- Install jacket onto core for impact test. Figure 2 illustrates the core assembly.

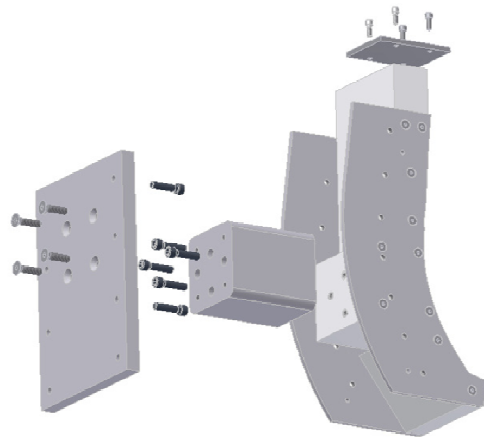

Figure 2 - Jacket Core Assembly

- Attach jacket and core to sled.
 - Jacket is to be mounted upside down on the front of sled. The assembly can be seen in Figure 3.
- With the probe free hanging, slide the sled toward the probe until the jacket is just touching the probe face.

NOTE: If jacket hits the track cross members when moving the sled, the attachment plate which holds the core is mounted upside down.



Figure 3 - BioRID Jacket Test Setup

BioRID Jacket Certification Test Procedure

- The test probe shall be of rigid metallic construction and concentric about its longitudinal axis.
- The test probe shall have a mass of 13.97 +/- 0.023 kg which includes all attached hardware and 1/3 of the weight of the suspension cables.
- The impacting end of the probe, perpendicular and concentric with the longitudinal axis of the probe, has a flat, continuous, and non-deformable 152.4 +/- 0.25 mm diameter impact face, extending rearward a minimum of 25 mm, with an edge radius of 12.7 mm.
- The BioRID Jacket mass including 15 attachment pins and water is 21.87 kg +/- 0.26 kg.
- The mass of the jacket core assembly is 11.50 kg +/-0.03 kg.
- Soak the test dummy in a controlled environment at any temperature between 19.0°C – 25.0°C and a relative humidity between 10 and 70 percent for a period of time no less than 4 hours prior to testing.
- Release the test probe so that it achieves a velocity between 1.50 – 1.55 m/s.
- At instance of contact, the probe should level within +/- 0.5 degrees and within 2mm of the impact point.
- The data acquisition system conforms to SAE recommended practice J211.
- The probe acceleration is to be collected and filtered using a Channel Class 180 phaseless filter.
- The sled acceleration is to be collected and filtered using a Channel Class 60 phaseless filter.
- Time zero is defined as the time of contact between the impact probe and the ETD device. All channels are to be at a zero level at this point.
- Wait at least 30 minutes between successive impacts on the same BioRID jacket.

BioRID Jacket Performance Specifications

- When the anterior surface of the BioRID jacket is impacted the peak impact probe force shall not be less than 1177N and not more than 1282N.
- The force shall be calculated by the product of the impact mass and the probe deceleration.
- The peak sled acceleration shall not be less than 15.7 m/s² and not more than 17.0 m/s².
- The peak sled velocity shall not be less than 0.375 m/s and not more than 0.411 m/s.
- The sled velocity is calculated by integrating the filtered sled acceleration.
- The BioRID jacket is to be certified annually.

BioRID Head Impact Pad Certification

Note: The Head Impact Pad Certification insures consistent material stiffness amongst head impact pads for the BioRID with Headrest Certification.

Required Instrumentation

- Impact Probe Accelerometer
- Sled Accelerometer
- Impact Probe
- BioRID Sled Track Assembly (without weight package)
- Velocity Measurement

Pretest Preparation

- Suspend the Impact Probe (specified in the test procedure below) so the longitudinal centerline of the probe is parallel +/- 0.5 degrees to the flight of the probe.
- With the impact probe free hanging, align the probe centerline to the alignment hole on the face of the impact sled as shown in Figure 1.
- Mount an accelerometer on the end of test probe opposite to the impact face with its sensitive axis in line with the longitudinal axis of the probe.
- Mount an accelerometer to the sled so its sensitive axis is parallel to the longitudinal centerline of the test probe.
- Mount the head impact pad directly on to the face of the sled as shown in Figure 4.

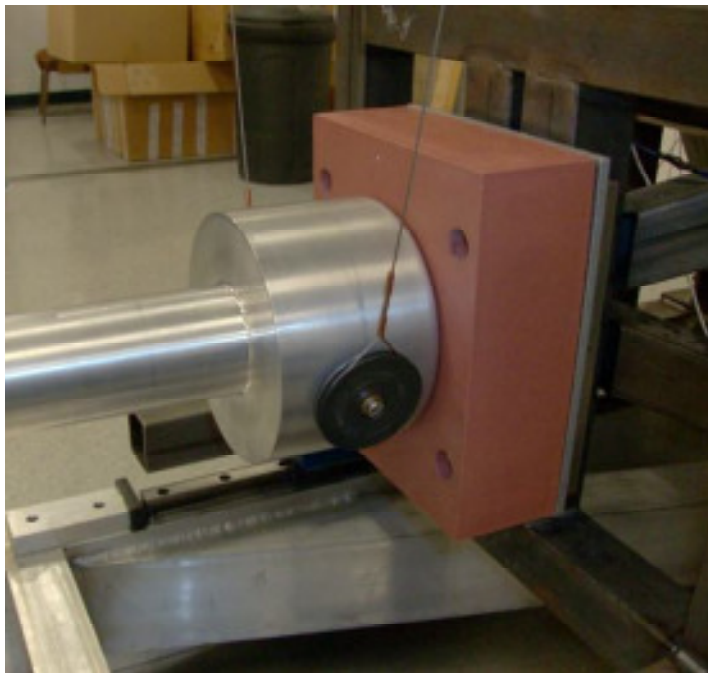

Figure 4 - Head Impact Pad Mounted on Sled

- With the probe free hanging, slide the sled toward the probe until the pad is just touching the probe face.

BioRID Head Impact Pad Certification Test Procedure

- The test probe shall be of rigid metallic construction and concentric about its longitudinal axis.
- The test probe shall have a mass of 13.97 +/- 0.023 kg which includes all attached hardware and 1/3 of the weight of the suspension cables.
- The impacting end of the probe, perpendicular and concentric with the longitudinal axis of the probe, has a flat, continuous, and non-deformable 152.4 +/- 0.25 mm diameter impact face, extending rearward a minimum of 25 mm, with an edge radius of 12.7 mm.
- Soak the test dummy in a controlled environment at any temperature between 19.0°C – 25.0°C and a relative humidity between 10 and 70 percent for a period of time no less than 4 hours prior to testing.
- Release the test probe so that it achieves a velocity between 2.07 – 2.12 m/s.
- The data acquisition system conforms to SAE recommended practice J211.
- At instance of contact, the probe should level within +/- 0.5 degrees and within 2mm of the impact point.
- The probe acceleration is to be collected and filtered using a Channel Class 180 phaseless filter.
- The sled acceleration is to be collected and filtered using a Channel Class 60 phaseless filter.
- Time zero is defined as the time of contact between the impact probe and the ETD device. All channels are to be at a zero level at this point.
- Wait at least 30 minutes between successive impacts on the same Head Impact Pad.

BioRID Head Impact Pad Performance Specifications

- When the surface of the Head Impact Pad is impacted the peak impact probe force shall not be less than **tbd** N and not more than **tbd** N.
- The force shall be calculated by the product of the impact mass and the probe deceleration.
- The peak sled acceleration shall not be less than **tbd** m/s² and not more than **tbd** m/s².
- The peak sled velocity shall not be less than **tbd** m/s and not more than **tbd** m/s.
- The sled velocity is calculated by integrating the filtered sled acceleration.
- The BioRID Head Impact Pad is to be certified annually.

BioRID Sled and Track Certification without Headrest

Note: The sled and track certification insures proper rail, sled and ETD installation and function.

Required Instrumentation

- Impact Probe
- Impact Probe Accelerometer
- BioRID Sled Track Assembly
- Sled Fixed Weight Package
- Sled Accelerometer
- Energy Transfer Device (ETD)
- Velocity Measurement

Pretest Preparation

- Suspend the Impact Probe so the longitudinal centerline of the probe is parallel +/- 0.5 degrees to the flight of the probe.
- Attach the Sled Track Assembly to the lift table so the linear guided rails are parallel to the longitudinal centerline of the probe.
- Attach the sled fixed weight package to the dummy mount on the sled.
- Mount an accelerometer on the end of test probe opposite to the impact face with its sensitive axis in line with the longitudinal axis of the probe.
- Mount an accelerometer to the sled so its sensitive axis is parallel to the longitudinal centerline of the test probe.
- With the impact probe free hanging, align the probe centerline to the alignment hole on the face of the impact sled as shown in Figure 1.
- Attach Energy Transfer Device (ETD) to sled face.
- While the probe is free hanging, slide the sled toward the probe until the ETD is just touching the probe face.
- Ensure the sled has at least 711 mm of unrestricted travel.
- Figure 5 illustrates the typical Sled and Track Certification Setup.

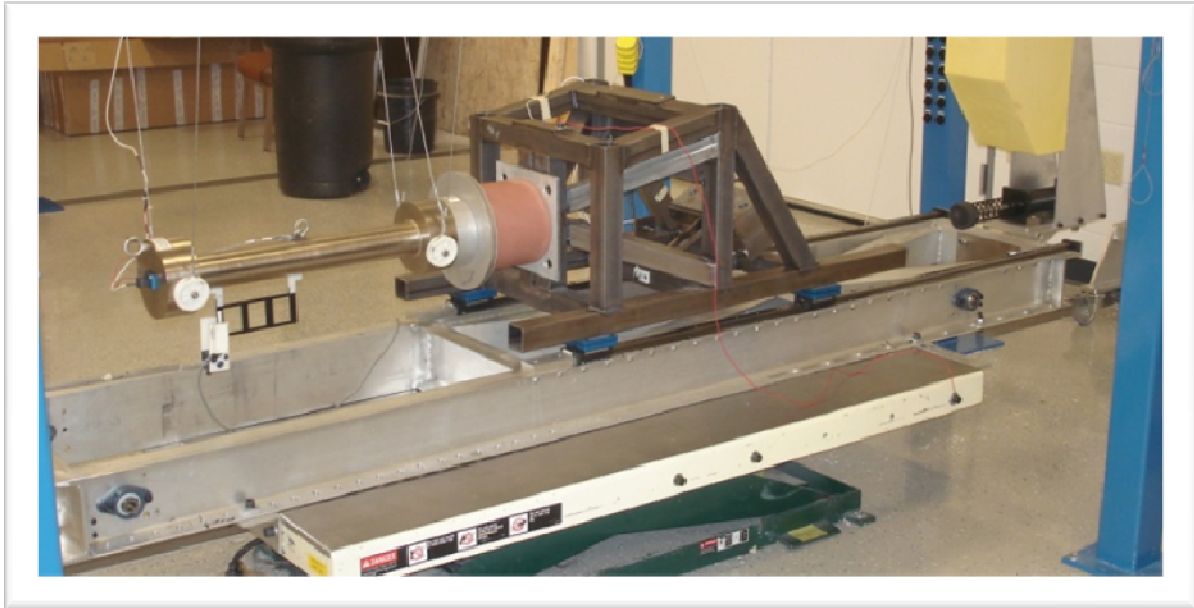

Figure 5 - BioRID Sled and Track Certification

BioRID Sled and Track Certification without Headrest Test Procedure

- The BioRID sled is to be a linear bearing guided sled with a mass of 44.25 kg +/- .05 kg including all attachments that move with the sled (except the ETD and ETD mounting screws)
- The mass of the ETD and ETD attachment bolts 2.55 kg +/- 0.25 kg.
- The mass of the sled fixed weight package including attachment bolts is 25.50 kg +/- 0.01 kg
- The test probe shall be of rigid metallic construction and concentric about its longitudinal axis.
- The test probe shall have a mass of 37.61kg +/- 0.1 kg which includes all attached hardware and 1/3 of the weight of the suspension cables.
- The impacting end of the probe, perpendicular and concentric with the longitudinal axis of the probe, has a flat, continuous, and non-deformable 254 +/- 0.25 mm diameter impact face with a 1mm - 2 mm thick Teflon® covering, extending rearward a minimum of 12.7 mm.
- Soak the test dummy in a controlled environment at any temperature between 19.0°C – 25.0°C and a relative humidity between 10 and 70 percent for a period of time no less than 4 hours prior to testing.
- The data acquisition system conforms to SAE recommended practice J211.
- Release the test probe so that it achieves a velocity between 4.7 m/s to 4.8 m/s
- At instance of contact, the probe should level within +/- 0.5 degrees and within 2mm of the impact point.
- The probe acceleration is to be collected and filtered using a Channel Class 180 phaseless filter.

- The sled acceleration is to be collected and filtered using a Channel Class 60 phaseless filter.
- Time zero is defined as the time of contact between the impact probe and the ETD device. All channels are to be at a zero level at this point.
- Wait at least 30 minutes between successive impacts on the same Head Impact Pad.

BioRID Sled and Track Certification without Headrest Performance Specifications

- When the ETD is impacted, the peak impactor probe force shall not be less than 8600 N and no more than 9800 N.
- The force shall be calculated by the product of the impactor mass and the probe deceleration.
- The peak sled acceleration shall not be less than 118 m/s^2 and not more than 136 m/s^2 .
- The peak sled velocity shall not be less than 2.65 m/s and not more than 2.95 m/s
- The sled velocity is calculated by integrating the filtered sled acceleration.
- The sled velocity decay between 50 ms and 150 ms shall not decay more than -1.5 (m/s)/s.
- The BioRID Sled and Track Certification should be completed prior to performing the BioRID Dummy Certification, Jacket Only Certification, and/or Head Impact Pad certification.

BioRID Dummy Certification without Headrest

Note: The BioRID dummy certification insures the performance of the dummy without using the headrest assembly.

Required Instrumentation

- Impact Probe
- Impact Probe Accelerometer
- BioRID Sled Track Assembly
- Sled Accelerometer
- Velocity Measurement
- Upper Spine (T1) Accelerometer
- Potentiometer Collets for Potentiometers
- Pot A – Neck Rotation at the Occipital Condyle
- Pot B – Neck Rotation at T1
- Pot C – Upper Spine Rotation at T1
- Pot D – Lower Spine Rotation at Sled
- Upper Neck Moment MY
- Digital Inclinometer
- Head Leveling Tool

Pretest Preparation

- Must pass BioRID Sled and Track Performance prior to performing this test.
- BioRID Jacket must have met BioRID Jacket Certification within the last year prior to performing this test.
- Check the dummy for any damage, loose or missing screws, loose or missing bumpers, etc.
- Attach the BioRID dummy (without lower torso and arms) to dummy mounting plate on the sled.
- Remove the head
- Verify the lateral angle of the OC plate is less than +/-0.5 degrees. Use the machined rail as a zero reference. Do not use the welded sled frame. Adjust dummy if necessary.
- Install upper neck load cell if not already in BioRID dummy.
- Reattach the head with the long OC pin in order to attach Pot A.
- Attach Pot A and Pot B to the dummy between T1 and the OC pin.
- Attach Pot C to opposite side of the T1 pin.
 - Tighten the nut against the potentiometer collects to keep them from rotating during the test.
- Install an “X” axis accelerometer to the T1 load cell shown in Figure 6.

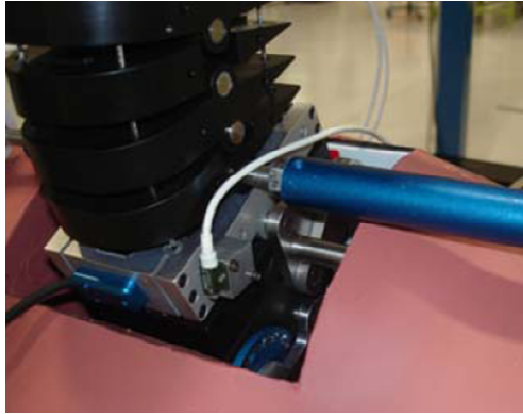

Figure 6 - X Accelerometer at T1

- Suspend the Impact Probe so the longitudinal centerline of the probe is parallel +/- 0.5 degrees to the flight of the probe.
- Mount an accelerometer on the end of test probe opposite to the impact face with its sensitive axis in line with the longitudinal axis of the probe.
- Mount an accelerometer to the sled so its sensitive axis is parallel to the longitudinal centerline of the test probe.
- With the impact probe free hanging, align the probe centerline to the alignment hole on the face of the impact sled as shown in Figure 1.
- Attach Energy Transfer Device (ETD) to sled face.
- With the probe free hanging, slide the sled toward the probe until the ETD is just touching the probe face.
- Level the head fore and aft to less than +/- 0.5 degrees (Figure 7).



Figure 7 - Head Setup Angle

BioRID Dummy Certification without Headrest Test Procedures

- The test probe shall be of rigid metallic construction and concentric about its longitudinal axis.

- The test probe shall have a mass of 37.61kg +/- 0.1 kg which includes all attached hardware and 1/3 of the weight of the suspension cables
- The impacting end of the probe, perpendicular and concentric with the longitudinal axis of the probe, has a flat, continuous, and non-deformable 254 +/- 0.25 mm diameter impact face with a 1mm - 2 mm thick Teflon® covering, extending rearward a minimum of 12.7 mm.
- The BioRID Jacket mass including attachment pins and bottom plate is 19.89 kg +/- 0.26 kg.
- The mass of the ETD and ETD attachment bolts 2.55 kg +/- 0.25 kg.
- Soak the test dummy in a controlled environment at any temperature between 19.0°C and 25.0°C and a relative humidity between 10 and 70 percent for a period of time no less than 4 hours prior to testing.
- Release the test probe so that it achieves a velocity between 4.7 m/s to 4.8 m/s
- At instance of contact, the probe should level within +/- 0.5 degrees and within 2mm of the impact point.
- The data acquisition system conforms to SAE recommended practice J211.
- The probe acceleration is to be collected and filtered using a Channel Class 180 phaseless filter.
- The sled acceleration is to be collected and filtered using a Channel Class 60 phaseless filter.
- The T1 acceleration is to be collected and filtered using a Channel Class 60 phaseless filter.
- Potentiometers are to be collected and filtered using a Channel Class 60 phaseless filter.
- Upper Neck Moment My is to be collected and filtered using a Channel Class 600 phaseless filter.
- Time zero is defined as the time of contact between the impact probe and the ETD device. All channels are to be at a zero level at this point.
- Wait at least 30 minutes between successive impacts on the same dummy.

BioRID Dummy Certification without Headrest Performance Specifications

- When the ETD is impacted the Peak Impactor Force shall not be less than 8000 N and no more than 9700 N.
- The force shall be calculated by the product of the impactor mass and the probe deceleration.
- The Peak Sled Acceleration shall not be less than 137 m/s² and not more than 170 m/s².
- The Sled Velocity shall not be less than 2.25 m/s and no more than 2.50 m/s between 20 ms and 30 ms.
- The Sled Velocity shall be no less than 2.1 m/s at 135 ms to 2.0 m/s at 140 ms and no more than 2.5 m/s at 135 ms to 2.4 m/s at 140 ms.
- The Peak T1 X Axis Acceleration shall not be less than 183 m/s² and not more than 267 m/s² occurring between 18.5 ms and 30.50 ms.

- The Peak Head Rotation about OC (Pot A) shall not be less than 11.5 degrees and not more than 16.50 degrees occurring between 25 ms and 70 ms.
- The Peak Head Rotation must also be between 2 degrees and -9 degrees between 125 ms and 135 ms.
- The Peak Neck Link Rotation (Pot B) shall not be less than 4.00 degrees and no more than 6.5 degrees between 18.5 ms and 28.5 ms.
- The Peak Neck Link Rotation (Pot B) must also be no less than -30.0 degrees between 98 ms and 108 ms, no less than -29.0 degrees between 165 ms and 175 ms and at no time should the data be more than -36.0 degrees.
- The T1 Rotation (Pot C) must be no less than -16.5 degrees between 73 ms and 78 ms and at no time be more than -19.0 degrees.
- The Total Head Rotation shall not be less than -25.0 degrees between 100 ms and 110 ms and between 170 ms and 190 ms and shall not be more than -41.0 degrees between 100 ms and 190 ms.
- The Total Head Rotation is the sum of Head Rotation (Pot A) and Neck Link Rotation (Pot B)
- The Total Thoracic Rotation shall not be less than -10.0 degrees between 125 ms and 135 ms and shall not be more than -21.0 degrees.
- The Total Thoracic Rotation is the sum of T1 Rotation (Pot C) and Lower Spine Rotation (Pot D).
- The Maximum Upper Neck Moment M_y shall less than 17.8 Nm and more than 7.7 Nm between 20 ms and 35 ms.
- The Minimum Upper Neck Moment M_y shall less than -23.5 Nm and more than -15.0 Nm between 66.0 ms and 83.0 ms.

BioRID Sled and Track Certification with Headrest

Note: The sled and track with headrest certification insures proper rail, sled and ETD installation and function.

Required Instrumentation

- Impact Probe
- Impact Probe Accelerometer
- BioRID Sled Track Assembly
- BioRID Headrest Assembly
- Head Impact Pad
- Sled Fixed Weight Package
- Sled Accelerometer
- Velocity Measurement
- ETD Device for Headrest Test

Pretest Preparation

- Suspend the Impact Probe so the longitudinal centerline of the probe is parallel +/- 0.5 degrees to the flight of the probe.
- Attach the Sled Track Assembly to the lift table so the linear guided rails are parallel to the longitudinal centerline of the probe.
- Remove the BioRID Dummy from sled (if needed).
- Attach the sled Fixed Weight Package to the sled.
- Attach the BioRID Headrest Assembly with Head Impact Pad to the sled.
- With the impact probe free hanging, align the probe centerline to the alignment hole on the face of the impact sled as shown in Figure 1.
- Attach Energy Transfer Device (ETD) to sled face. This ETD is different than the one used for the BioRID Sled and Track Certification without Headrest. Figure 8 shows the basic setup for the Sled and Track with Headrest test setup.

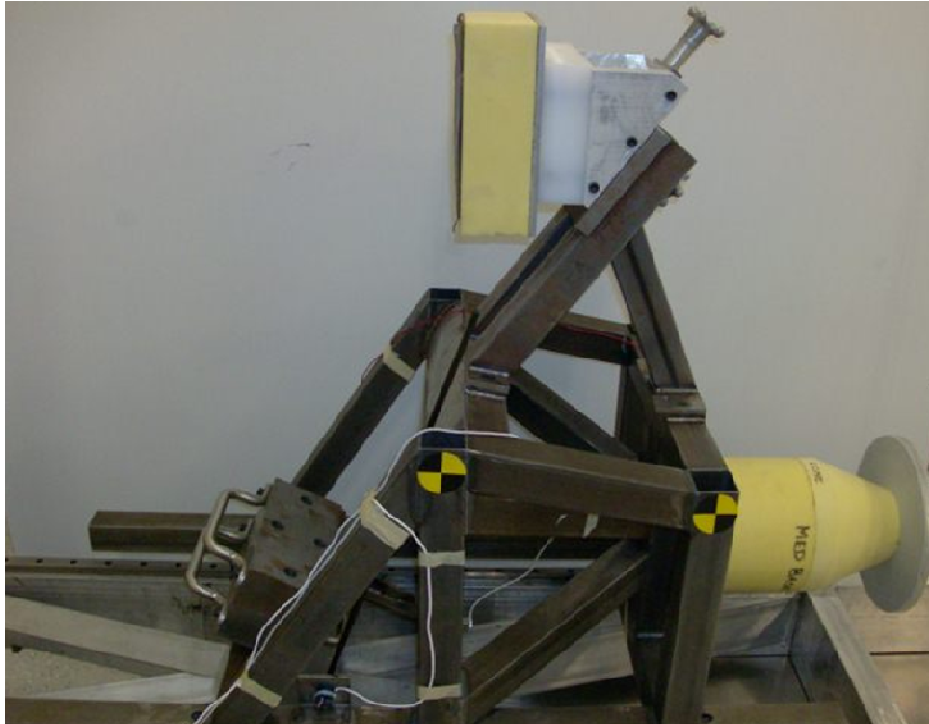

Figure 8 - BioRID Sled and Track Certification with Headrest Test Setup

- Pull back the probe until the impact face is 152 mm +/- 1 mm rearward of its free hanging position.
- With the probe in this position, slide the sled toward the probe until the ETD is just touching the probe face. This is to ensure the travel length is at least 711mm.

BioRID Sled and Track Certification with Headrest Test Procedure

- The BioRID sled is to be a linear bearing guided sled with a mass of 44.25 kg +/- .05 kg including all attachments that move with the sled (except the ETD and ETD mounting screws)
- The mass of the ETD and ETD attachment 2.33 kg +/- 0.25 kg.
- The mass of the Headrest Assembly is to be 6.00 kg +/- 0.02 kg
- The mass of the sled fixed weight package including attachment bolts is 25.50 kg +/- 0.01 kg
- The test probe shall be of rigid metallic construction and concentric about its longitudinal axis.
- The test probe shall have a mass of 118.5kg +/- 0.1 kg which includes all attached hardware and 1/3 of the weight of the suspension cables.
- The impacting end of the probe, perpendicular and concentric with the longitudinal axis of the probe, has a flat, continuous, and non-deformable 254 +/- 0.25 mm diameter impact face with a 1 mm - 2 mm thick Teflon® covering, extending rearward a minimum of 12.7 mm.

- Mount an accelerometer on the end of test probe opposite to the impact face with its sensitive axis in line with the longitudinal axis of the probe.
- Mount an accelerometer to the sled so its sensitive axis is parallel to the longitudinal centerline of the test probe.
- Soak the test dummy in a controlled environment at any temperature between 19.0°C – 25.0°C and a relative humidity between 10 and 70 percent for a period of time no less than 4 hours prior to testing.
- The data acquisition system conforms to SAE recommended practice J211.
- Release the test probe so that it achieves a velocity between 4.70 m/s to 4.75 m/s
- At instance of contact, the probe should level within +/- 0.5 degrees.
- The probe acceleration is to be collected and filtered using a Channel Class 180 phaseless filter.
- The sled acceleration is to be collected and filtered using a Channel Class 60 phaseless filter.
- Time zero is defined as the time of contact between the impact probe and the ETD device. All channels are to be at a zero level at this point.
- Wait at least 30 minutes between successive impacts on the same sled.

BioRID Sled and Track Certification with Headrest Performance Specifications

- When the ETD is impacted, the peak impactor probe force shall not be less than 6825 N and no more than 8750 N.
- The force shall be calculated by the product of the impactor mass and the probe deceleration.
- The peak sled acceleration shall not be less than 77.0 m/s² and not more than 94.0 m/s².
- The peak sled velocity shall not be less than 4.40 m/s and not more than 4.49 m/s
- The sled velocity is calculated by integrating the filtered sled acceleration.
- The sled velocity decay between 120 ms and 180 ms shall not decay more than -1.5 (m/s)/s.
- The BioRID Sled and Track with Headrest Certification should be completed prior to performing the BioRID Dummy with Headrest Certification.

BioRID Dummy Certification with Headrest

Note: The BioRID dummy with headrest certification insures the performance of the dummy when used with a headrest assembly.

Required Instrumentation

- Impact Probe
- Impact Probe Accelerometer
- BioRID Sled Track Assembly
- Sled Accelerometer
- Velocity Measurement
- Head Contact Switch
- Upper Neck Force FX
- Upper Neck Force FZ
- Upper Neck Moment MY
- Lower Neck Force FX
- Lower Neck Force FZ
- Lower Neck Moment MY
- Digital Inclinator
- Head Leveling Tool

Pretest Preparation

- Must pass BioRID Sled and Track with Headrest Certification prior to performing this test.
- BioRID Jacket must have met BioRID Jacket Certification within the last year prior to performing this test.
- Suspend the Impact Probe so the longitudinal centerline of the probe is parallel +/- 0.5 degrees to the flight of the probe.
- Attach the Sled Track Assembly to the lift table so the linear guided rails are parallel to the longitudinal centerline of the probe.
- Attach the BioRID Headrest Assembly with Head Impact Pad to the sled.
- Attach the BioRID dummy (without lower torso and arms) to dummy mounting plate on the sled.
- With the impact probe free hanging, align the probe centerline to the alignment hole on the face of the impact sled as shown in Figure 1.
- Attach Energy Transfer Device (ETD) to sled face.
- Pull back the probe until the impact face is 152 mm +/- 1 mm rearward of its free hanging position.
- With the probe in this position, slide the sled toward the probe until the ETD is just touching the probe face. This is to ensure the travel length is at least 711mm.

BioRID Dummy Certification with Headrest Test Procedure

- The BioRID sled is to be a linear bearing guided sled with a mass of 44.25 kg +/- .05 kg including all attachments that move with the sled (except the ETD and ETD mounting screws)
- The mass of the ETD and ETD attachment 2.33 kg +/- 0.25 kg.
- The mass of the Headrest Assembly is to be 6.00 kg +/- 0.02 kg
- The mass of the sled fixed weight package including attachment bolts is 25.50 kg +/- 0.01 kg
- The test probe shall be of rigid metallic construction and concentric about its longitudinal axis.
- The test probe shall have a mass of 118.5kg +/- 0.1 kg which includes all attached hardware and 1/3 of the weight of the suspension cables.
- The impacting end of the probe, perpendicular and concentric with the longitudinal axis of the probe, has a flat, continuous, and non-deformable 254 +/- 0.25 mm diameter impact face with a 1 mm - 2 mm thick Teflon® covering, extending rearward a minimum of 12.7 mm.
- Mount an accelerometer on the end of test probe opposite to the impact face with its sensitive axis in line with the longitudinal axis of the probe.
- Mount an accelerometer to the sled so its sensitive axis is parallel to the longitudinal centerline of the test probe.
- Soak the test dummy in a controlled environment at any temperature between 19.0°C – 25.0°C and a relative humidity between 10 and 70 percent for a period of time no less than 4 hours prior to testing.
- The data acquisition system conforms to SAE recommended practice J211.
- Release the test probe so that it achieves a velocity between 5.20 m/s to 5.30 m/s
- At instance of contact, the probe should level within +/- 0.5 degrees.
- The probe acceleration is to be collected and filtered using a Channel Class 180 phaseless filter.
- The sled acceleration is to be collected and filtered using a Channel Class 60 phaseless filter.
- Time zero is defined as the time of contact between the impact probe and the ETD device. All channels are to be at a zero level at this point.
- Wait at least 30 minutes between successive impacts on the same dummy.

BioRID Dummy Certification with Headrest Performance Specifications

- When the ETD is impacted, the peak impactor probe force shall not be less than 9000 N and no more than 11000 N.
- The force shall be calculated by the product of the impactor mass and the probe deceleration.
- The peak sled acceleration shall not be less than 75.0 m/s² and not more than 100 m/s².
- The peak sled velocity shall not be less than 4.20 m/s and not more than 5.0 m/s
- The sled velocity is calculated by integrating the filtered sled acceleration.
- *Dummy Channels specifications to be determined.*