

Status report of “Reversing Motion” in VRU-Proxi Informal Working Group.

JAPAN,
on behalf of
VRU-Proxi Informal Working Group.

Status of VRU-Proxi Informal Working Group

Working Document (ECE-TRANS-WP.29-GRSG-2019-16e) submitted.

Informal Document to update WD was planned for explanation in this GRSG session.

VRU-Proxi 11th session was held on 24-26 September.

Line by line review of updated WD and discussion had been proceeded.

Regarding hot discussion at the session, IWG reached the conclusion that it is still too premature to finalize the draft of the regulation in this GRSG session.

Today, we will explain about recent status and invite all of you to further discussions.

Summary of proposed regulations (1)

Proposal for a new UN Regulation on the approval of devices for reversing motion and motor vehicles with regard to the driver's awareness of vulnerable road users behind vehicles

Scope

All categories of M and N.

Exemption;

- No consensus on language on exemptions, if any.

Summary of proposed regulations (2)

Multi modal approach

- Indirect vision
(Rear-View Camera, close-proximity rear-mounted mirror*, if appropriate in combination with conventional R46 devices)
- Detection systems (e.g. ultrasonic system)
- Direct vision through back window
- Combinations of methods or devices

Field of view for direct vision and/or indirect vision devices

- 0.8m height x 9 poles
- 1st row: 15cmX15cm patch on any part of pole
- 2nd and 3rd row: Whole pole
- 1 row to be seen by 1 device

* Still under discussion which vehicles may use this and under which conditions it should be allowed.

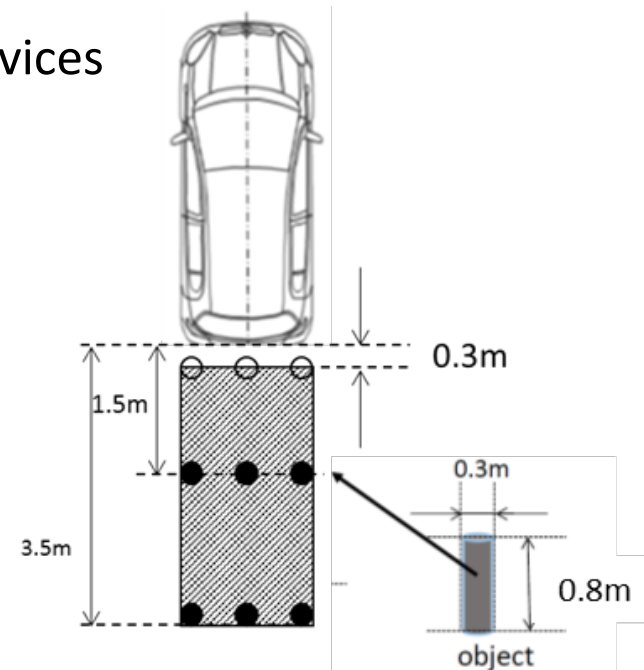

Summary of proposed regulations (3)

Part I Components, Part II Installation

Impact test of device mounted on rear of vehicle: [Not needed]

Mirrors (still no consensus)

- Interior (fitted at the top of the rear window on the inside of the vehicle), Exterior mirror.

Rear-View Camera

- Image quality, Display object size
- Overlays, Screen change (still no consensus)
- Deactivation (still no consensus)
- System latency

Detection system

- Detection area: 0.2m~1.0m *Equivalent for 3.5m by vision
- Detection latency: 0.6s
- Auditory/Optical/Haptic information : 2 of 3 methods

Remaining key discussion points

- 1) Exemption from the scope.
Solo tractor etc.
- 2) System response time after start (for Rear-View Camera.)
Door open, ignition, gear etc. considering MT, AT vehicles for Rear-View Camera integrated with IVI system.
- 3) Overlays
Transparency, contents etc.
- 4) Deactivation
“Driver’s modified view” includes switched off or not.
- 5) Direct view by turning around of the driver and including vehicle with or without (additional) Close-proximity rear view mirror.
Only for certain vehicle length, single seating row, ... etc.
- 6) Test procedure (fine-tuning only, broad consensus on test approach)

Schedule

2019

October, November E-mail and/or Web discussions

November 24-26 VRU-Proxi 12th meeting @ Brussels, Belgium
PLEASE ATTEND THIS MEETING, ESPECIALLY CPs.

December Final preparation of Working Document

2020

January Submit Working Document to 118th GRSG

February 5-7 VRU-Proxi 13th meeting @ Osaka, Japan

March 30-April 3 Proposal to 118th GRSG (TOR of IWG)

If you have any comments or questions for the draft regulation, please let us know. And also, we welcome you to join further discussions.

**Contact: Reversing Motion TF chair Akinari HIRAO, Ph. D.
a-hirao@mail.nissan.co.jp**

Thank you for your attention.